

This drawing is confidential and must not be reproduced or used without the consent of EXM

Ce dessin est confidentiel et ne doit pas être reproduit ou utilisé sans le consentement de EXM

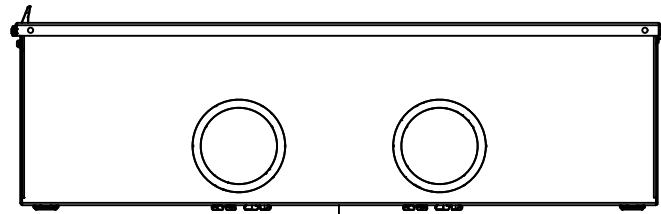

TOP

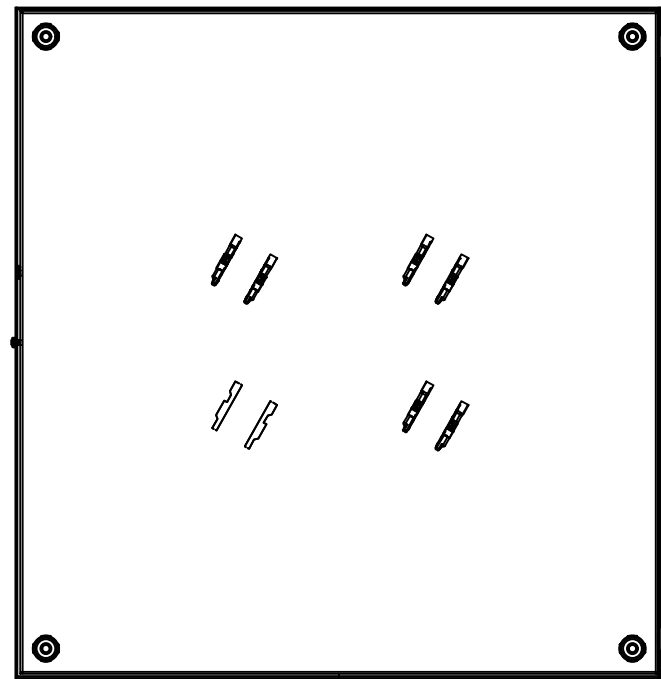

BACK

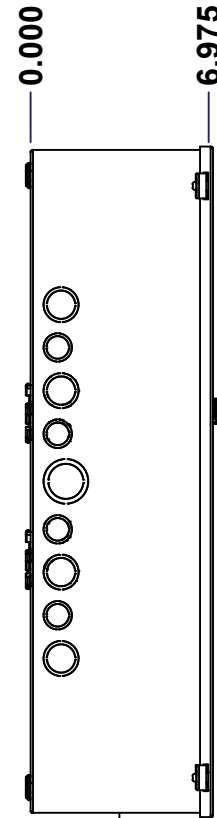

LEFT

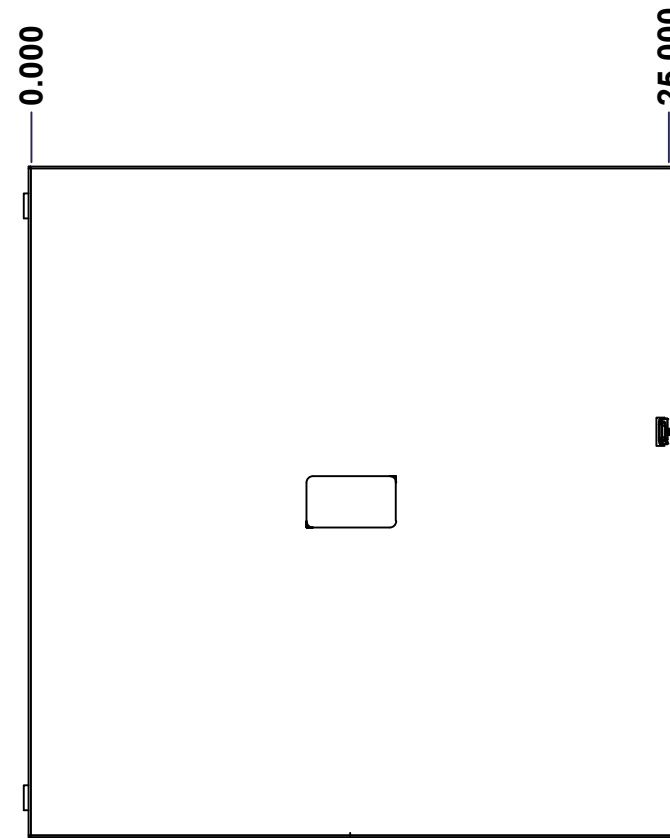

FRONT

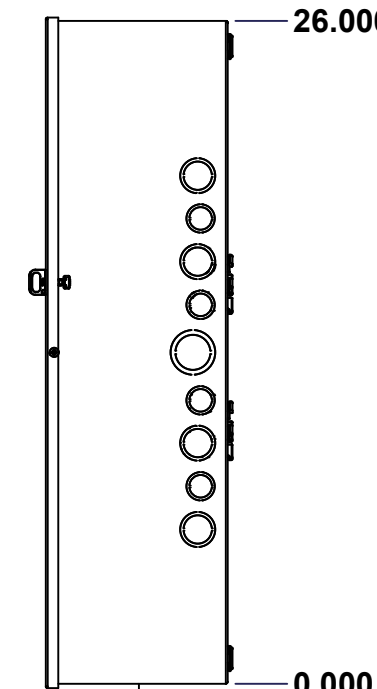

RIGHT

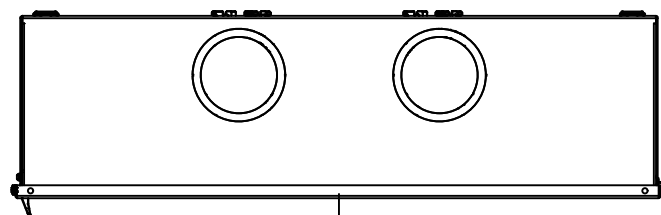

BOTTOM

No.	Revisions	Date	By/Par

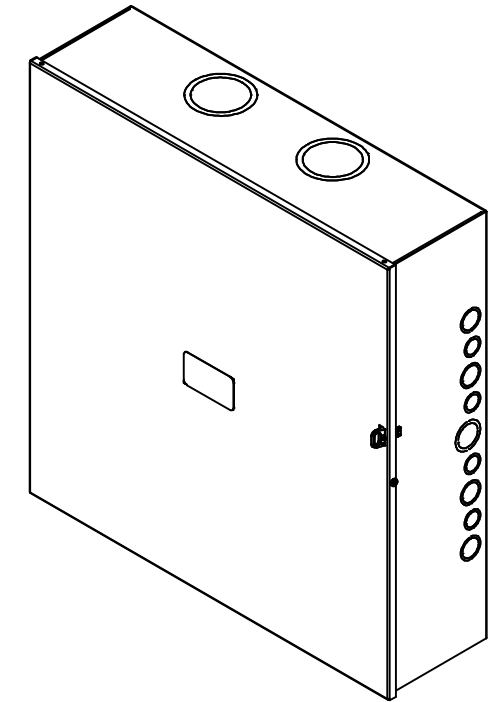

Isometric View



Tél: (450) 979-4373
 Fax: (450) 979-4626
www.exmweb.com

Flatness
Aplatissement

Max 3.0mm

Projection

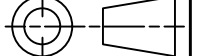

Customer Client	Date
Drawn By Dessiné Par BoxCad: BoxCad	Date 09-Oct-24
Material Matière 16 Ga Cold Rolled A1008 CS Type B (1.4mm)	
Color Couleur Asa-61 Grey	Finish Fini Smooth
Description 1100B 26" x 25" x 6.975" Assembly	Detail Rev.
Part Number Numéro Pièce 1100B603	Rev. 0

SEE BILL OF MATERIAL ON LAST PAGE

This drawing is confidential and must not be reproduced or used without the consent of EXM

Ce dessin est confidentiel et ne doit pas être reproduit ou utilisé sans le consentement de EXM

NOTE	
ITEM	DESCRIPTION
1	NEMA 1 Enclosure (IP20)
2	C/W Standard ground studs on box and cover
3	W/O Inner panel
4	W/O Inner panel mounting studs

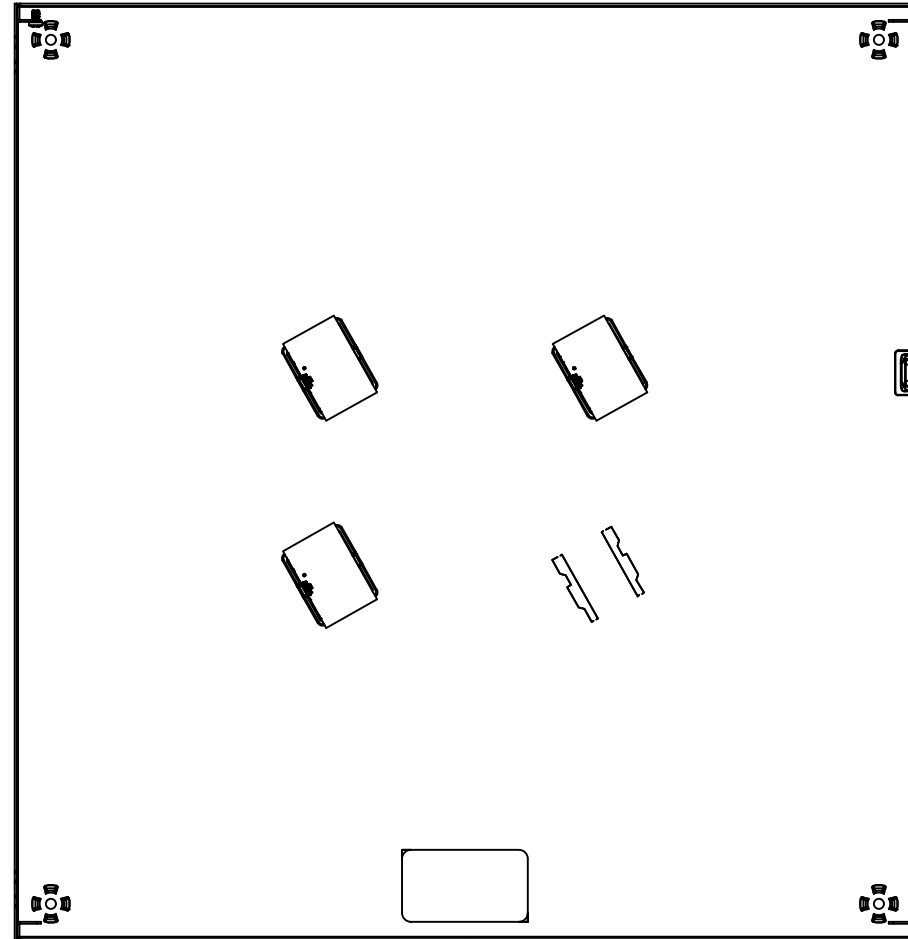

No.	Revisions	Date	By/Par

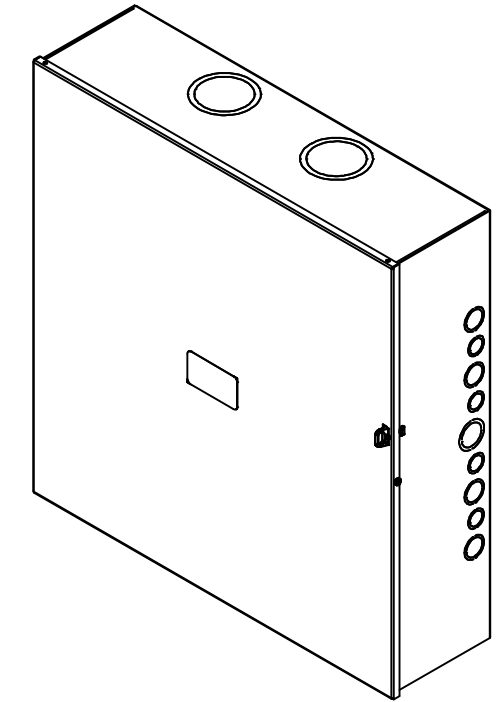

Isometric View

PACKING		
ITEM	QTY	DESCRIPTION
Cardboard sleeve	2	Top and Bottom
Cardboard strip	2	Between back of enclosure and inner panel
Plastic bag	1	To protect cover surface and inside gasket
Cardboard corner	4	To reinforced for the plastic strap tightening
Plastic strap - Black	2	To Squeeze the 2 cardboard sleeve together
Packaging label	3	White label with PN
Plastic strap- Green	2	To secure the enclosure to the wood pallet
Wood Pallet	1	2" deeper and 3" larger than enclosure size

1	STK-Q-77450	3	Plastic Padlock Provision
1	1100B603C	0	1100B 18" x 25" Cover
1	STK-K-02700	0	1412 T Accessory Kit
1	1100B603B	0	1100B 26" x 25" x 6.975" Body
3	881 BRB400	0	Aluminum Lug with Insulator
Qty	Part Number	Rev	Description
Parts List			

	Tél: (450) 979-4373 Fax: (450) 979-4626 www.exmweb.com	Flatness Aplatissement Max 3.0mm Projection
	Customer Client Drawn By Dessiné Par Material Matière Color Couleur Description Part Number Numéro Pièce	Date Date 09-Oct-24 16 Ga Cold Rolled A1008 CS Type B (1.4mm) Asa-61 Grey Finish Fini Smooth Detail Rev. 1100B 26" x 25" x 6.975" Assembly Rev. 0
1100B603		

This drawing is confidential and must not be reproduced or used without the consent of EXM

Ce dessin est confidentiel et ne doit pas être reproduit ou utilisé sans le consentement de EXM

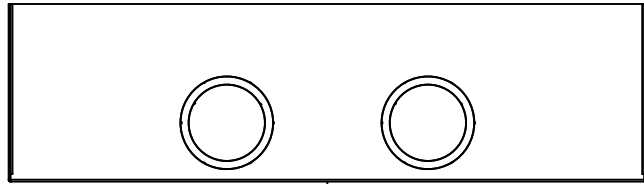

TOP

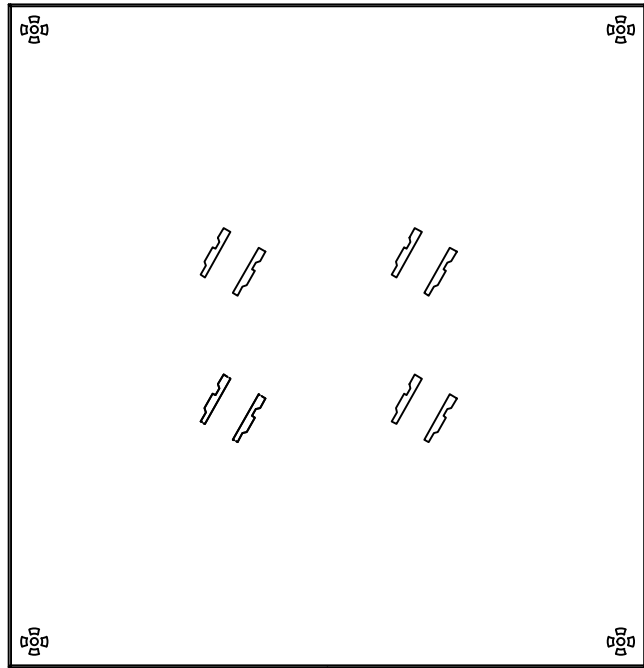

BACK

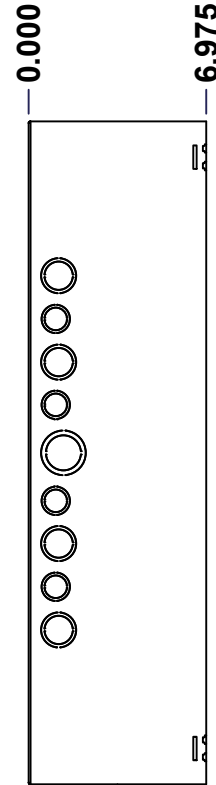

LEFT

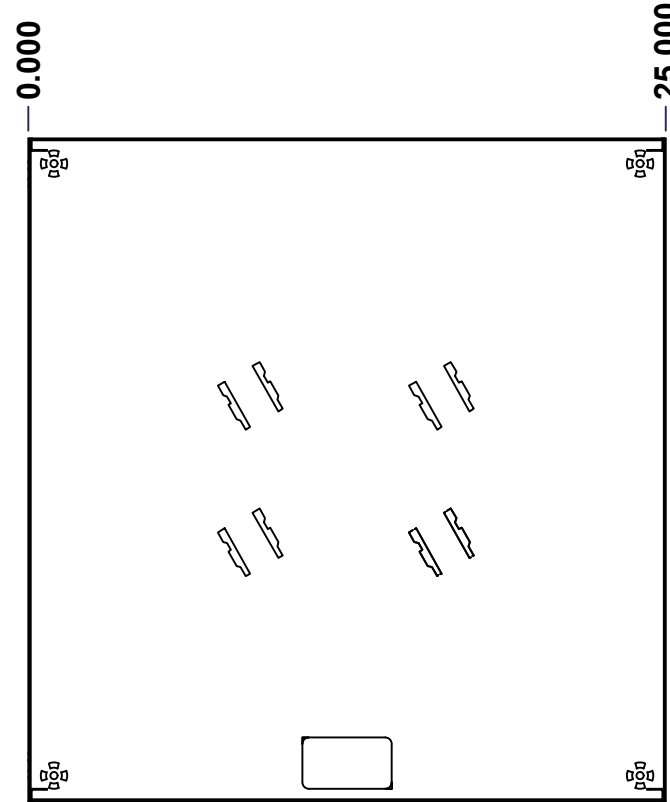

FRONT

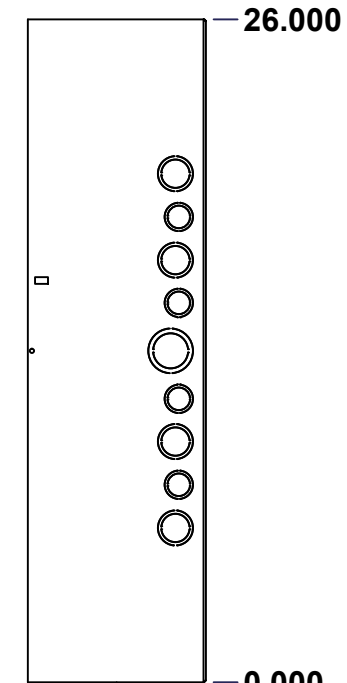

RIGHT

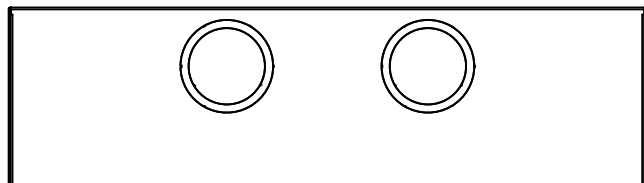

BOTTOM

No.	Revisions	Date	By/Par

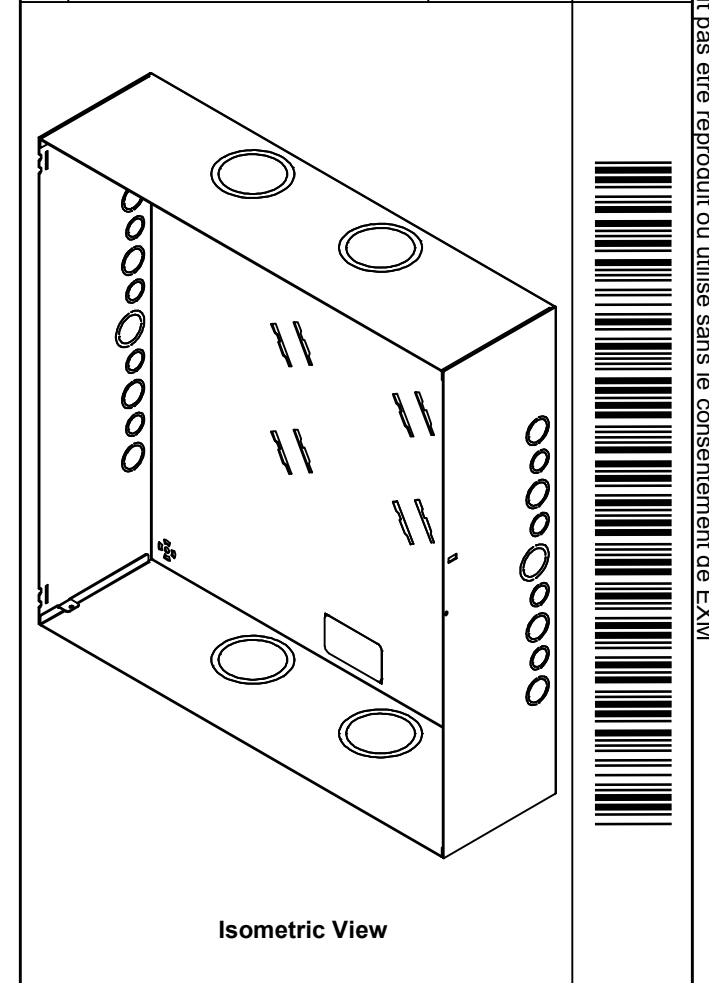

Isometric View

	Flatness Aplatissement Max 3.0mm
	Projection
Customer Client	Date
Drawn By Dessiné Par BoxCad: BoxCad	Date 09-Oct-24
Material Matière 16 Ga Cold Rolled A1008 CS Type B (1.4mm)	
Color Couleur Asa-61 Grey	Finish Fini Smooth
Description 1100B 26" x 25" x 6.975" Body	
Part Number Numéro Pièce 1100B603B	
Rev. 0	3 / 10

SEE BILL OF MATERIAL ON LAST PAGE

This drawing is confidential and must not be reproduced or used without the consent of EXM

Ce dessin est confidentiel et ne doit pas être reproduit ou utilisé sans le consentement de EXM

STANDARD FEATURES ARE NOT LISTED IN THIS HOLE TABLE			
HOLE TABLE - TOP VIEW (CUSTOM FEATURE ONLY)			
CUT-OUT	XDIM	YDIM	DESCRIPTION
1	16.438	2.313	DKO Ø3.625 - 3.000
2	8.563	2.313	DKO Ø3.625 - 3.000

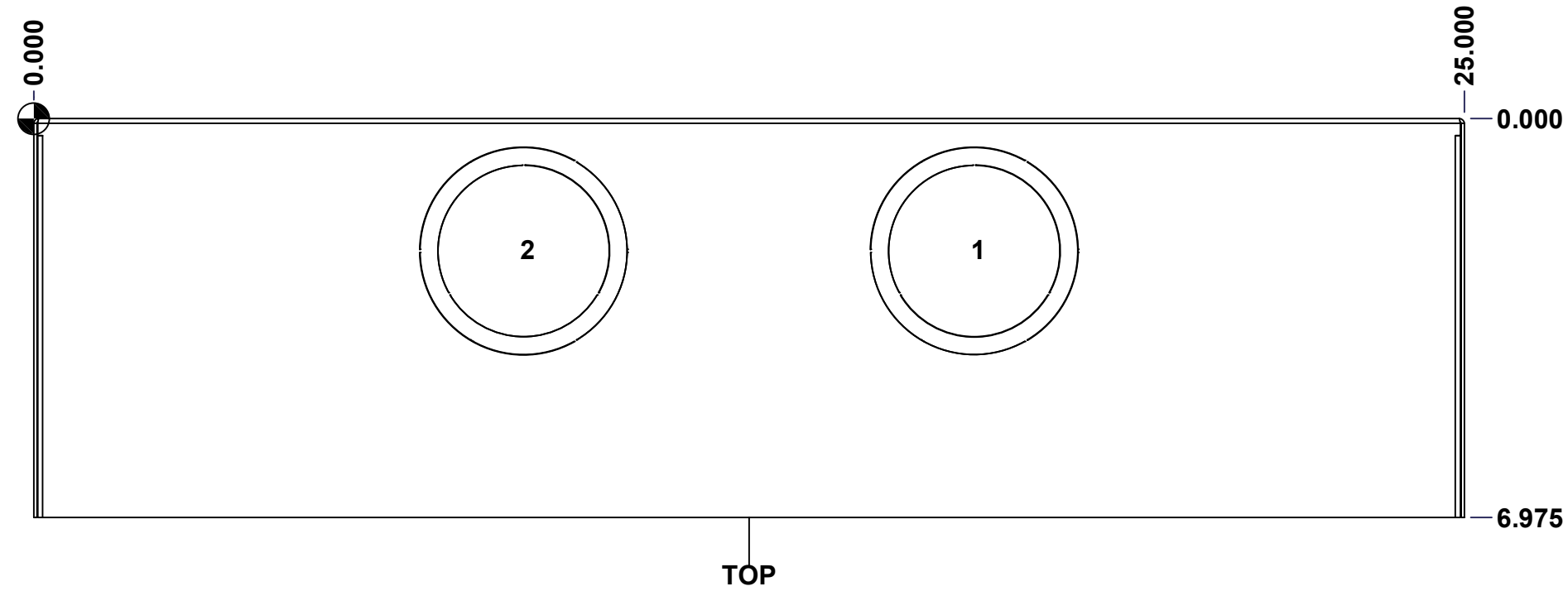

	Description	Status	
	1100B 26" x 25" x 6.975" Body	(NULL)	
	Part Number Numéro Pièce	Rev.	4
	1100B603B	0	10

This drawing is confidential and must not be reproduced or used without the consent of EXM

Ce dessin est confidentiel et ne doit pas être reproduit ou utilisé sans le consentement de EXM

STANDARD FEATURES ARE NOT LISTED IN THIS HOLE TABLE

HOLE TABLE - RIGHT VIEW (CUSTOM FEATURE ONLY)

CUT-OUT	XDIM	YDIM	DESCRIPTION
1	1.188	19.939	DKO Ø1.375 - 1.125
2	1.063	18.251	DKO Ø1.125 - 0.875
3	1.188	16.563	DKO Ø1.375 - 1.125
4	1.063	14.875	DKO Ø1.125 - 0.875
5	1.375	13.000	DKO Ø1.750 - 1.375
6	1.063	11.125	DKO Ø1.125 - 0.875
7	1.188	9.437	DKO Ø1.375 - 1.125
8	1.063	7.749	DKO Ø1.125 - 0.875
9	1.188	6.061	DKO Ø1.375 - 1.125

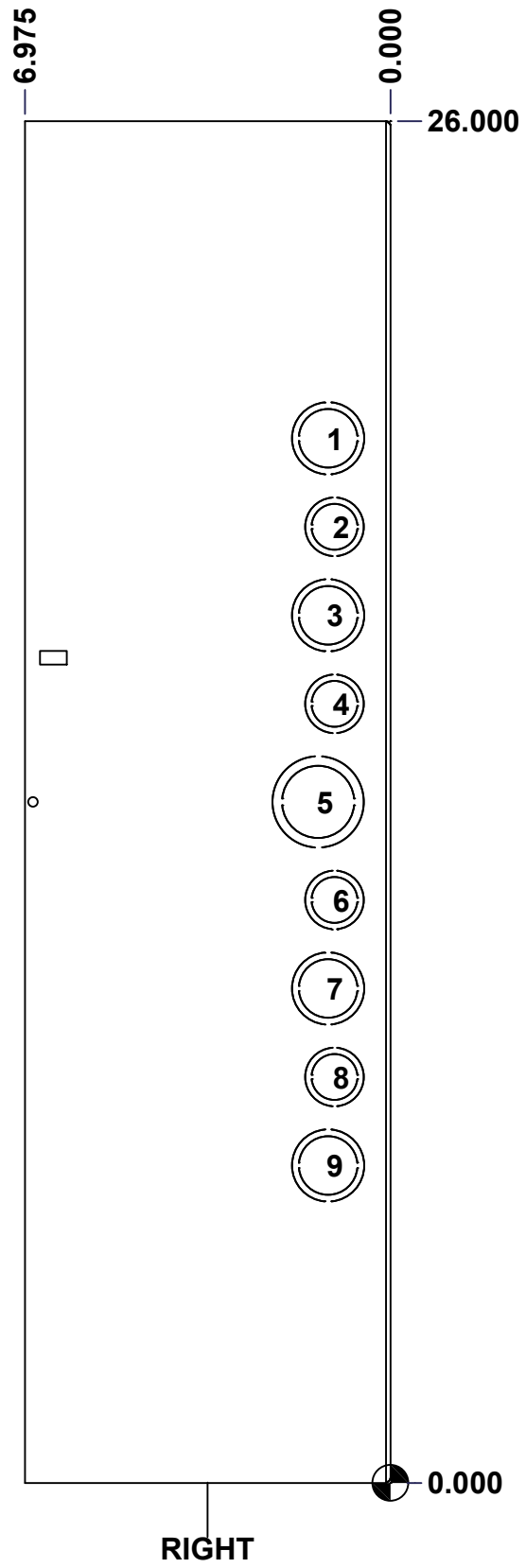

	Description 1100B 26" x 25" x 6.975" Body	Status (NULL)
	Part Number Numéro Pièce 1100B603B	Rev. 5 0

This drawing is confidential and must not be reproduced or used without the consent of EXM

Ce dessin est confidentiel et ne doit pas être reproduit ou utilisé sans le consentement de EXM

STANDARD FEATURES ARE NOT LISTED IN THIS HOLE TABLE			
HOLE TABLE - BOTTOM VIEW (CUSTOM FEATURE ONLY)			
CUT-OUT	XDIM	YDIM	DESCRIPTION
1	16.438	2.313	DKO Ø3.625 - 3.000
2	8.563	2.313	DKO Ø3.625 - 3.000

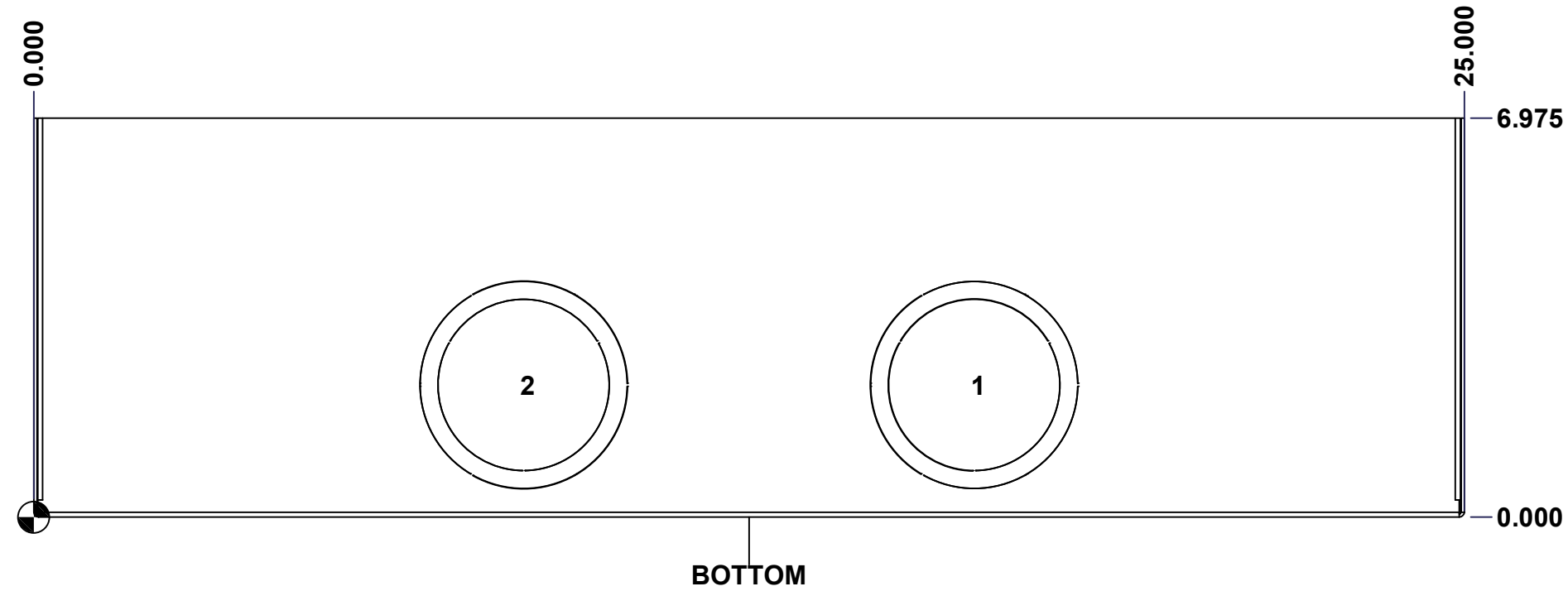

	Description	Status	
	1100B 26" x 25" x 6.975" Body	(NULL)	
	Part Number Numéro Pièce	Rev.	6
	1100B603B	0	10

This drawing is confidential and must not be reproduced or used without the consent of EXM

Ce dessin est confidentiel et ne doit pas être reproduit ou utilisé sans le consentement de EXM

STANDARD FEATURES ARE NOT LISTED IN THIS HOLE TABLE

HOLE TABLE - LEFT VIEW (CUSTOM FEATURE ONLY)

CUT-OUT	XDIM	YDIM	DESCRIPTION
1	1.188	19.939	DKO Ø1.375 - 1.125
2	1.063	18.251	DKO Ø1.125 - 0.875
3	1.188	16.563	DKO Ø1.375 - 1.125
4	1.063	14.875	DKO Ø1.125 - 0.875
5	1.375	13.000	DKO Ø1.750 - 1.375
6	1.063	11.125	DKO Ø1.125 - 0.875
7	1.188	9.437	DKO Ø1.375 - 1.125
8	1.063	7.749	DKO Ø1.125 - 0.875
9	1.188	6.061	DKO Ø1.375 - 1.125

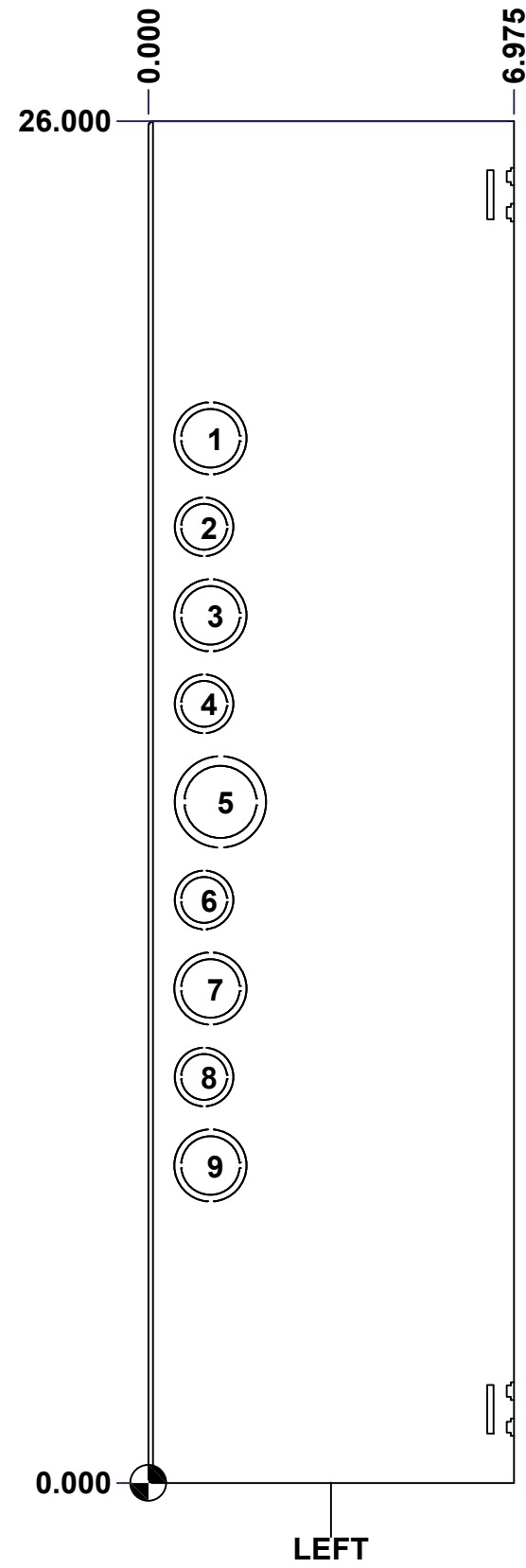



	Description	Status	
	1100B 26" x 25" x 6.975" Body	(NULL)	
	Part Number Numéro Pièce	Rev.	7
	1100B603B	0	10

This drawing is confidential and must not be reproduced or used without the consent of EXM

Ce dessin est confidentiel et ne doit pas être reproduit ou utilisé sans le consentement de EXM

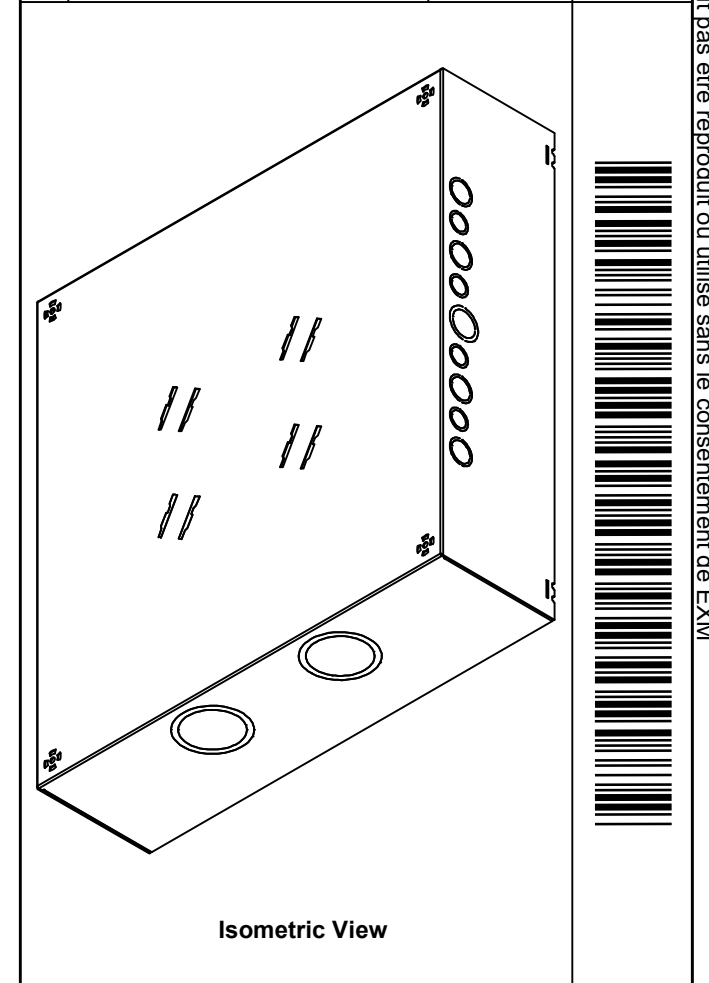
No.	Revisions	Date	By/Par

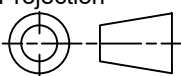

 Tél: (450) 979-4373 Fax: (450) 979-4626 www.exmweb.com		Flatness Aplatissement Max 3.0mm Projection 
Customer Client	Date	
Drawn By / Dessiné Par: BoxCad: BoxCad	Date: 09-Oct-24	
Material / Matière: 16 Ga Cold Rolled A1008 CS Type B (1.4mm)		
Color / Couleur: Asa-61 Grey	Finish / Fini: Smooth	
Description: 1100B 26" x 25" x 6.975" Body		Detail Rev.
Part Number / Numéro Pièce: 1100B603B		Rev. 8 / 10

Qty	Part Number	Rev	Description
1	STK-P-02400S	0	Powder Paint (Asa-61 Grey / Smooth)
1	STK-S-00100	0	3.5" x 2" Silver Milar Flexcon Sticker
1	1100B603B-P	0	1100B 26" x 25" x 6.975" Body Part
Parts List			

This drawing is confidential and must not be reproduced or used without the consent of EXM

Ce dessin est confidentiel et ne doit pas être reproduit ou utilisé sans le consentement de EXM

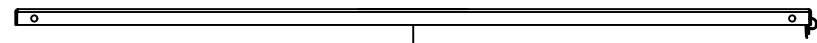

TOP

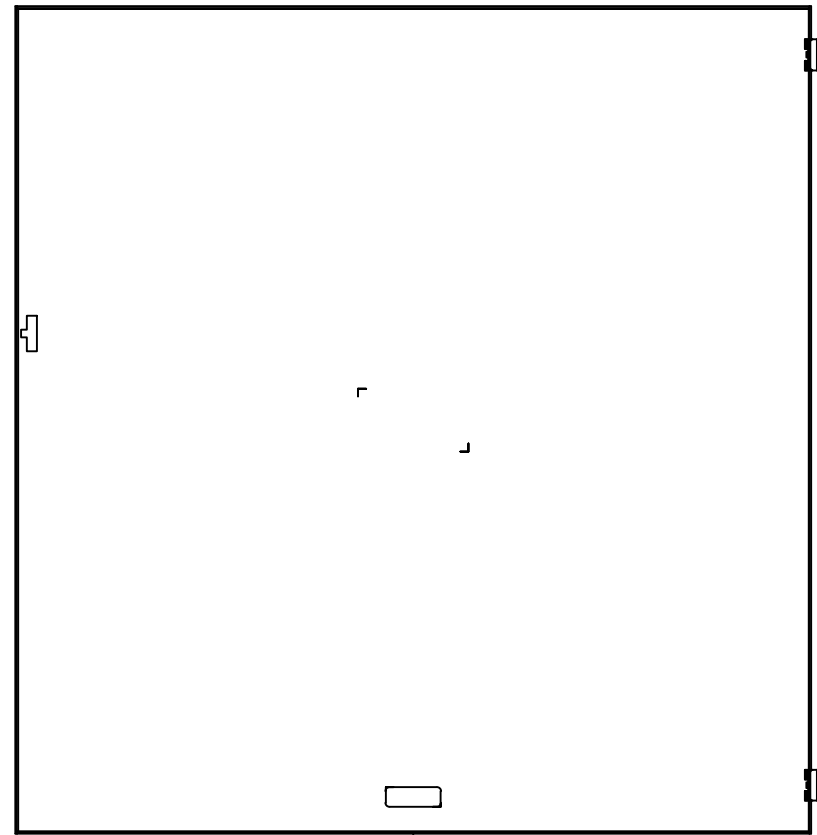

BACK

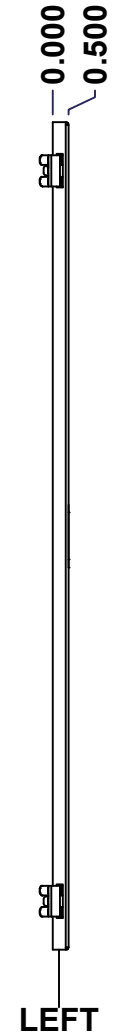

LEFT

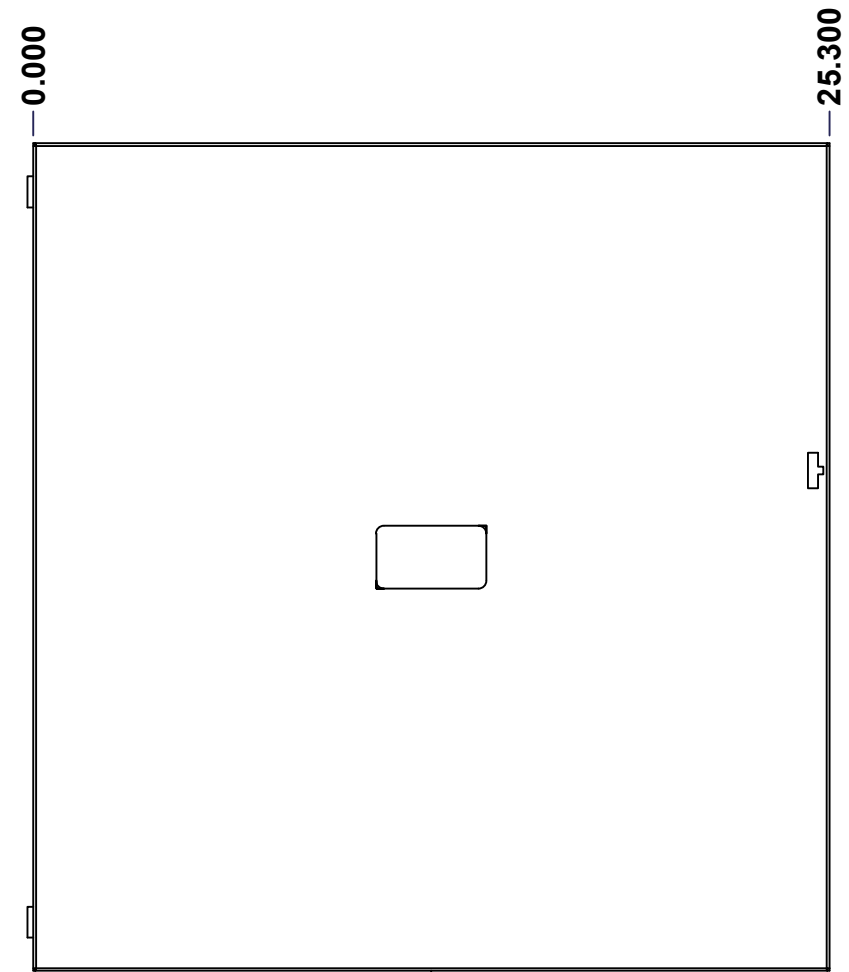

FRONT

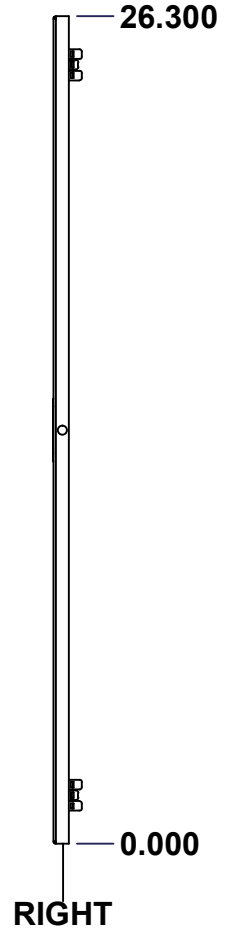

RIGHT

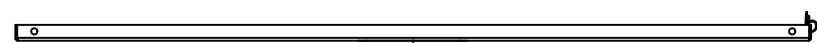

BOTTOM

No.	Revisions	Date	By/Par

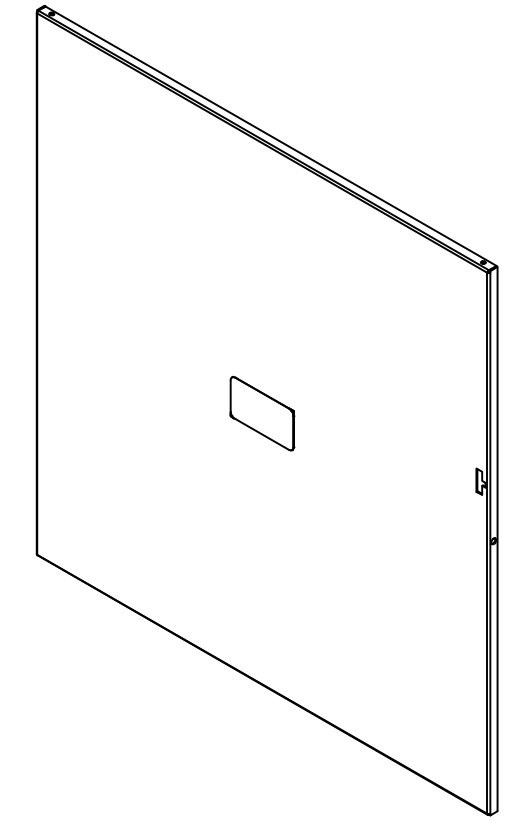

Isometric View

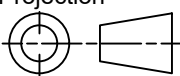

 Tél: (450) 979-4373 Fax: (450) 979-4626 www.exmweb.com		Flatness Aplatissement Max 3.0mm Projection 
Customer Client	Date	
Drawn By Dessiné Par	BoxCad: BoxCad	Date 09-Oct-24
Material Matière	16 Ga Cold Rolled A1008 CS Type B (1.4mm)	
Color Couleur	Asa-61 Grey	Finish Fini Smooth
Description	Detail Rev.	
1100B 18" x 25" Cover		
Part Number Numéro Pièce	Rev.	9
1100B603C	0	10

SEE BILL OF MATERIAL ON LAST PAGE

This drawing is confidential and must not be reproduced or used without the consent of EXM

Ce dessin est confidentiel et ne doit pas être reproduit ou utilisé sans le consentement de EXM

No.	Revisions	Date	By/Par

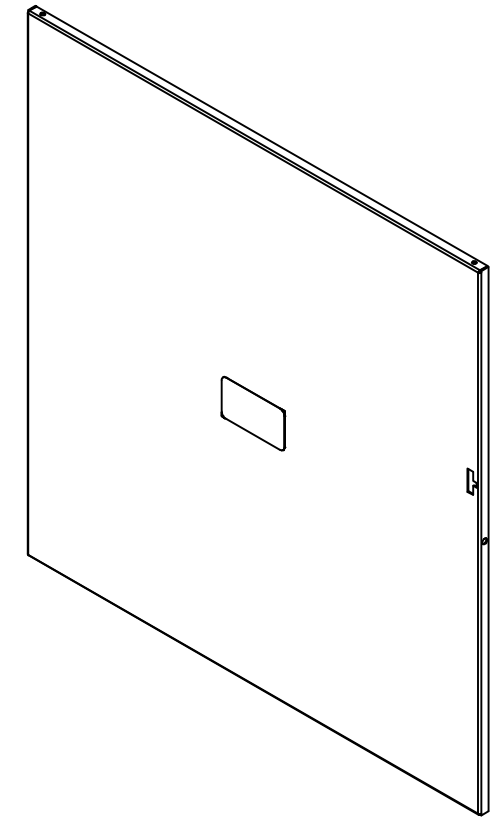

Isometric View



Tél: (450) 979-4373
 Fax: (450) 979-4626
www.exmweb.com

Flatness
Aplatissement

Max 3.0mm

Projection

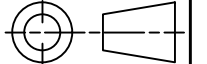

Customer Client	Date
Drawn By / Dessiné Par: BoxCad: BoxCad	Date: 09-Oct-24
Material / Matière: 16 Ga Cold Rolled A1008 CS Type B (1.4mm)	

Color / Couleur: Asa-61 Grey	Finish / Fini: Smooth
------------------------------	-----------------------

Description: 1100B 18" x 25" Cover	Detail Rev.
------------------------------------	-------------

Part Number / Numéro Pièce: 1100B603C	Rev. 0	10 / 10
--	--------	---------

QTY	Part Number	Rev	Description
1	STK-P-02400S	0	Powder Paint (Asa-61 Grey / Smooth)
1	STK-S-00250	0	15.8mm x 44.45mm Silver Milar Sticker
1	STK-S-00100	0	3.5" x 2" Silver Milar Flexcon Sticker
2	STK-Q-33361	0	Spring Steel Hinge
1	1100B603C-P	0	1100B 26" x 25" x 0" Cover Part
Parts List			