

This drawing is confidential and must not be reproduced or used without the consent of EXM

Ce dessin est confidentiel et ne doit pas être reproduit ou utilisé sans le consentement de EXM

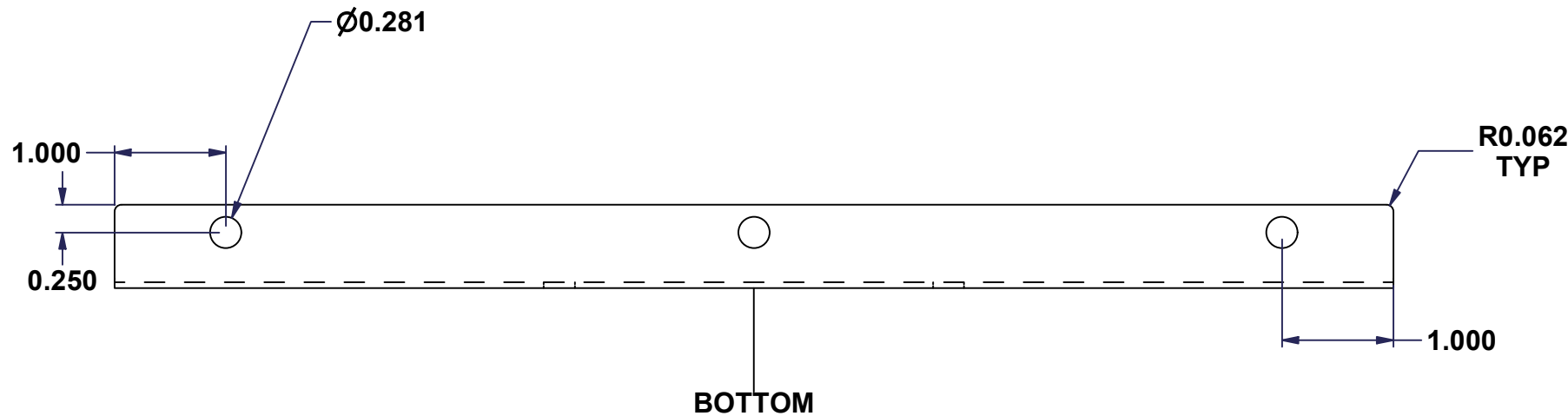

| No. | Revisions | Date | By/Par |
|-----|-----------|------|--------|
| | | | |
| | | | |
| | | | |
| | | | |
| | | | |

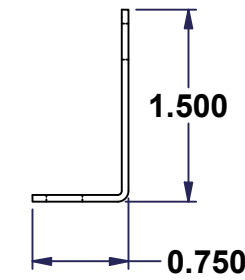
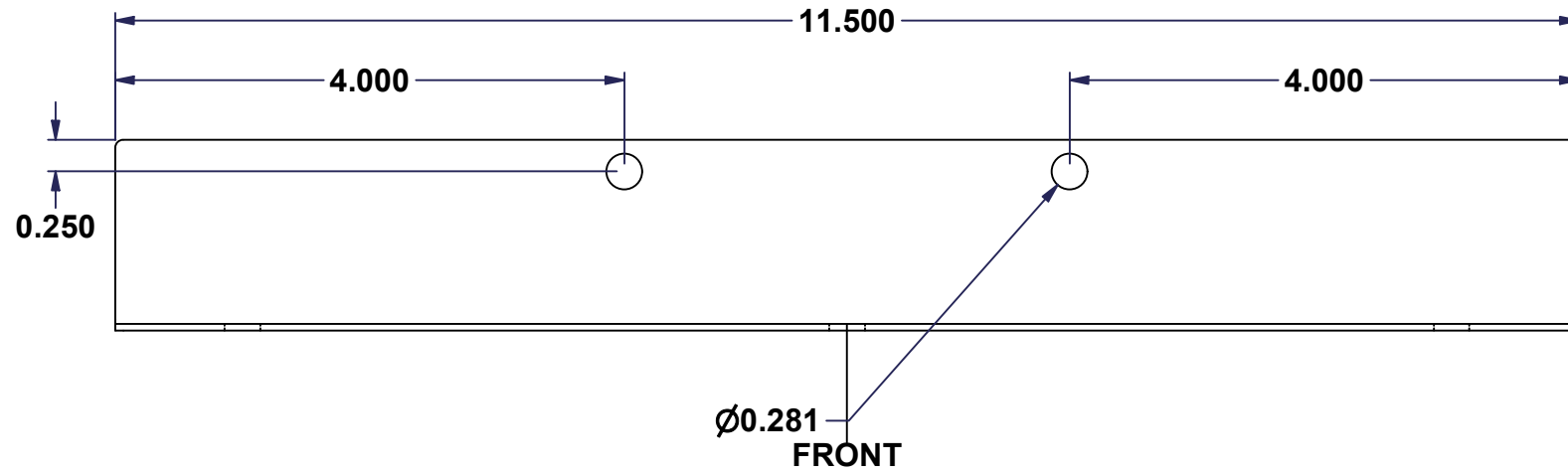
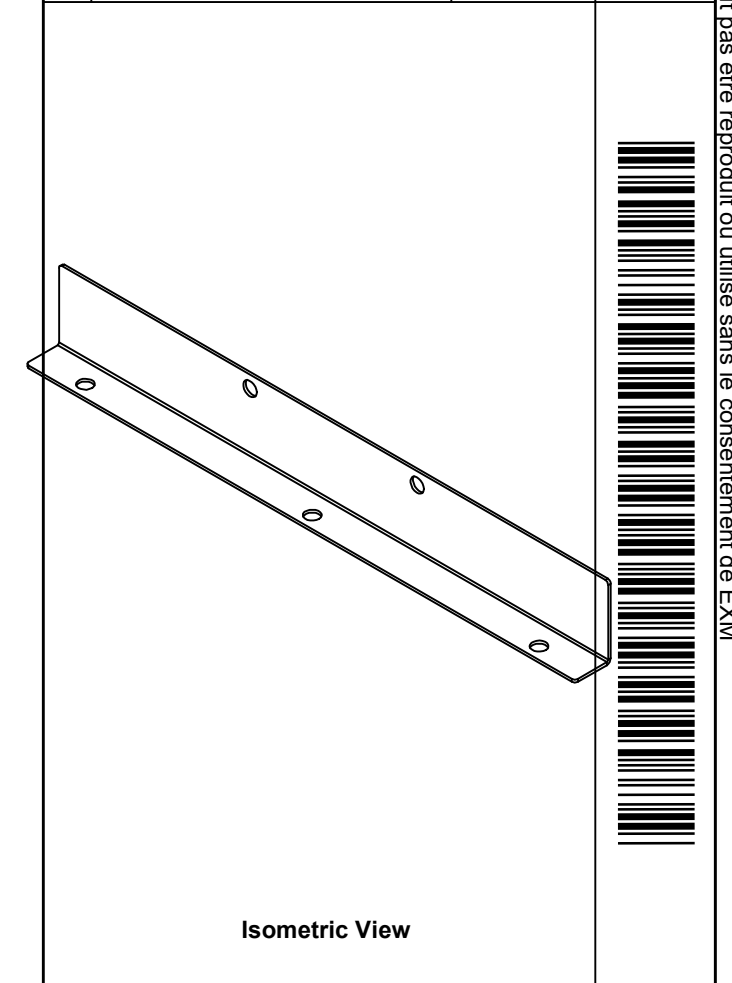

Tél: (450) 979-4373
 Fax: (450) 979-4626
www.exmweb.com

Flatness
Aplatissement

Max 3.0mm

Projection

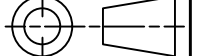

| | |
|---------------------------------------------------------------|----------------|
| Customer Client | Date |
| Drawn By Dessiné Par BoxCad: BoxCad | Date 10-Jul-25 |
| Material Matière 16 Ga Cold Rolled A1008 CS Type B (1.4mm) | |

| | |
|------------------------------|-----------------------|
| Color Couleur Asa-61 Grey | Finish Fini Smooth |
|------------------------------|-----------------------|

| | |
|---------------------------------------------------|-------------|
| Description 1100BA 2.5" x 12" x 0.75" Assembly | Detail Rev. |
|---------------------------------------------------|-------------|

| | | |
|-----------------------------------------------|---------------|--------|
| Part Number Numéro Pièce 1100BA2012 | Rev. 0 | 1 2 |
|-----------------------------------------------|---------------|--------|

SEE BILL OF MATERIAL ON LAST PAGE

This drawing is confidential and must not be reproduced or used without the consent of EXM

Ce dessin est confidentiel et ne doit pas être reproduit ou utilisé sans le consentement de EXM

| No. | Revisions | Date | By/Par |
|-----|-----------|------|--------|
| | | | |
| | | | |
| | | | |
| | | | |
| | | | |

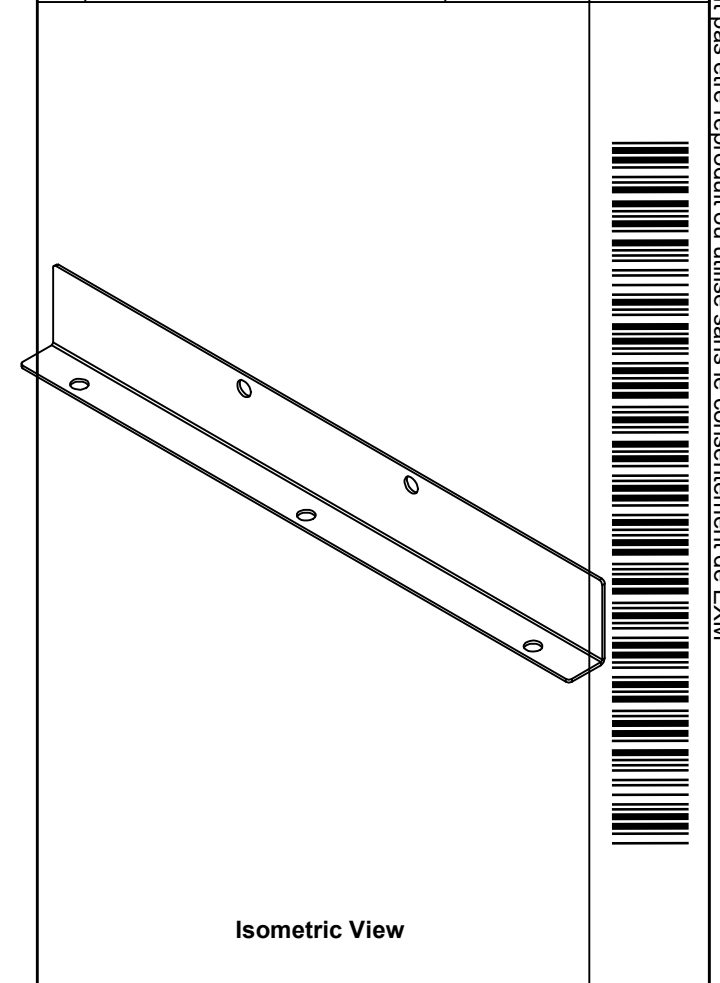

Tél: (450) 979-4373
 Fax: (450) 979-4626
www.exmweb.com

Flatness
Aplatissement
Max 3.0mm
Projection

| | |
|---------------------------------------------------------------|-----------------------|
| Customer Client | Date |
| Drawn By / Dessiné Par: BoxCad: BoxCad | Date: 10-Jul-25 |
| Material / Matière: 16 Ga Cold Rolled A1008 CS Type B (1.4mm) | |
| Color / Couleur: Asa-61 Grey | Finish / Fini: Smooth |

| Qty | Part Number | Rev | Description |
|------------|--------------|-----|-------------------------------------|
| 1 | STK-P-02400S | 0 | Powder Paint (Asa-61 Grey / Smooth) |
| 1 | 1100BA2012-P | 0 | 1100BA 2.5" x 12" Cover Part |
| Parts List | | | |

| | |
|-------------------------------------------------|-------------|
| Description: 1100BA 2.5" x 12" x 0.75" Assembly | Detail Rev. |
| Part Number / Numéro Pièce: 1100BA2012 | Rev. 0 / 2 |