

This drawing is confidential and must not be reproduced or used without the consent of EXM

Ce dessin est confidentiel et ne doit pas être reproduit ou utilisé sans le consentement de EXM

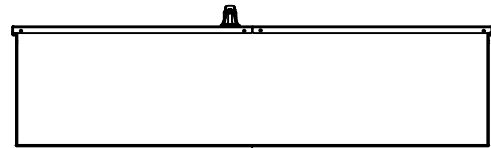

TOP

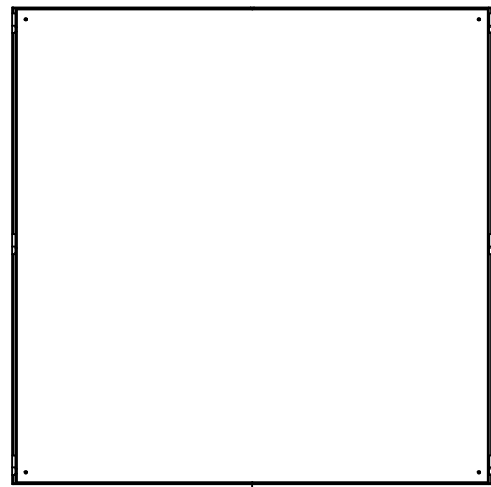

BACK

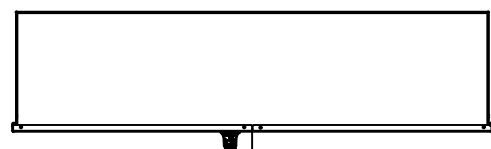

BOTTOM

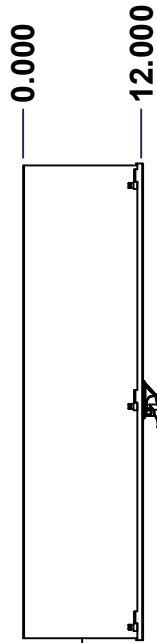

LEFT

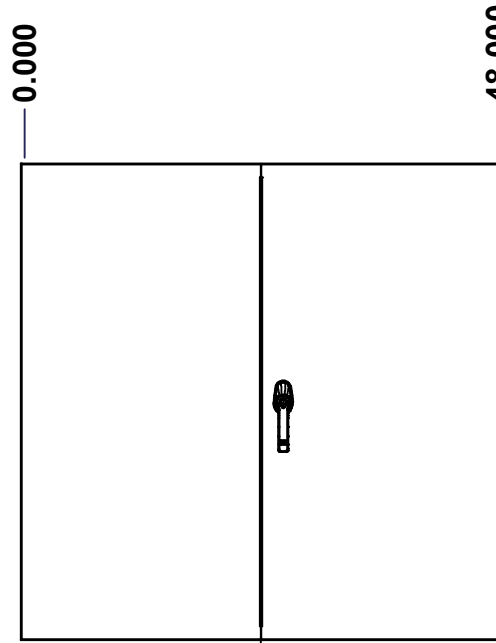

FRONT

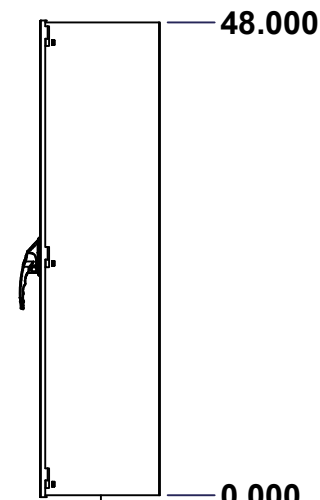

RIGHT

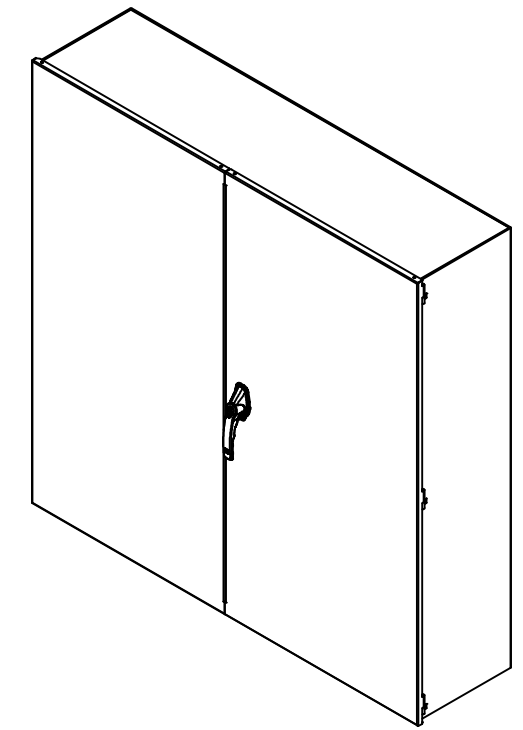

Isometric View

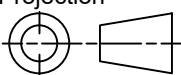

No.	Revisions	Date	By/Par

 Tél: (450) 979-4373 Fax: (450) 979-4626 www.exmweb.com		Flatness Aplatissement Max 3.0mm Projection 
Customer Client	Date	
Drawn By Dessiné Par	BoxCad: BoxCad	Date 06-Jun-23
Material Matière	14 Ga Cold Rolled A1008 CS Type B (1.7mm)	
Color Couleur	Asa-61 Grey	Finish Fini Smooth
Description	Detail Rev.	
1100CCDD 48" x 48" x 12" Assembly		
Part Number Numéro Pièce	Rev.	1
1100CCDD484812	0	12

SEE BILL OF MATERIAL ON LAST PAGE

This drawing is confidential and must not be reproduced or used without the consent of EXM

Ce dessin est confidentiel et ne doit pas être reproduit ou utilisé sans le consentement de EXM

NOTE	
ITEM	DESCRIPTION
1	NEMA 1 Enclosure (IP20)
2	C/W Inner panel (Included)
3	C/W Standard inner panel mounting studs

No.	Revisions	Date	By/Par

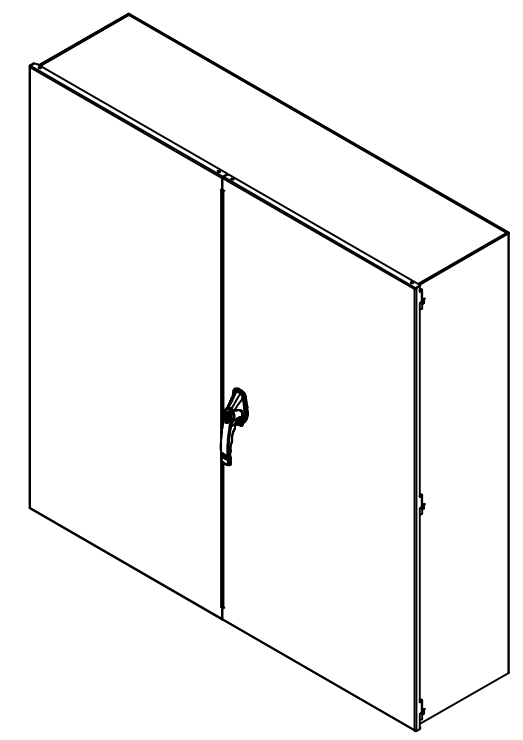

Isometric View

EXM
www.exmweb.com

Tél: (450) 979-4373
Fax: (450) 979-4626

Flatness
Aplatissement
Max 3.0mm

Projection

Customer Client	Date
Drawn By / Dessiné Par: BoxCad: BoxCad	Date: 06-Jun-23
Material / Matière: 14 Ga Cold Rolled A1008 CS Type B (1.7mm)	
Color / Couleur: Asa-61 Grey	Finish / Fini: Smooth

PACKING		
ITEM	QTY	DESCRIPTION
Cardboard sleeve	2	Top and Bottom
Plastic strap - Black	2	To Squeeze 2 cardboard sleeve together
Packaging label	3	White label with PN

Qty	Part Number	Rev	Description
1	1100CCDD484812IP	0	1100CCDD 48" x 48" Inner Panel
16	STK-Q-07310	3	Flange Lock Nut M8
1	1100CCDD484812FD	0	1100CCDD 48" x 48" Cover
1	1100CCDD484812LD	0	1100CCDD 48" x 48" Cover
1	1100CCDD484812B	0	1100CCDD 48" x 48" x 12" Body

Parts List

Description: 1100CCDD 48" x 48" x 12" Assembly	Detail Rev.
Part Number / Numéro Pièce: 1100CCDD484812	Rev. 0

This drawing is confidential and must not be reproduced or used without the consent of EXM

Ce dessin est confidentiel et ne doit pas être reproduit ou utilisé sans le consentement de EXM



TOP

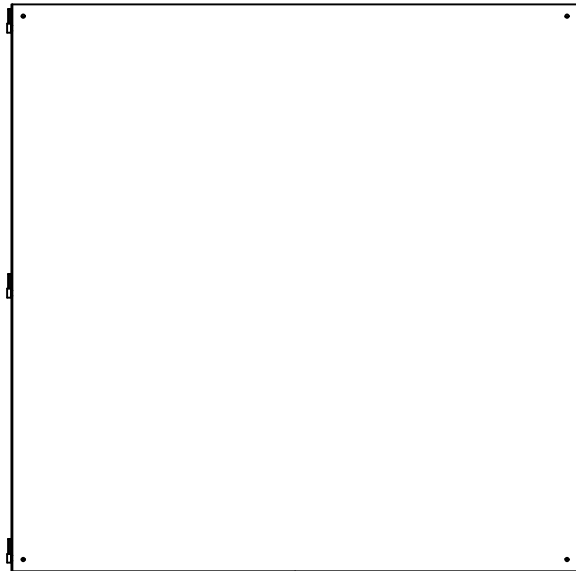

BACK

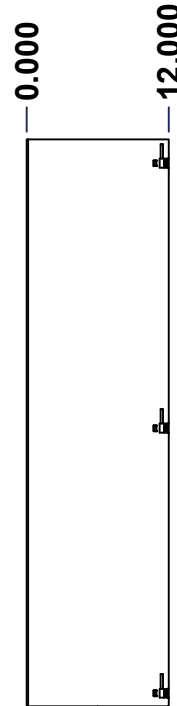

LEFT

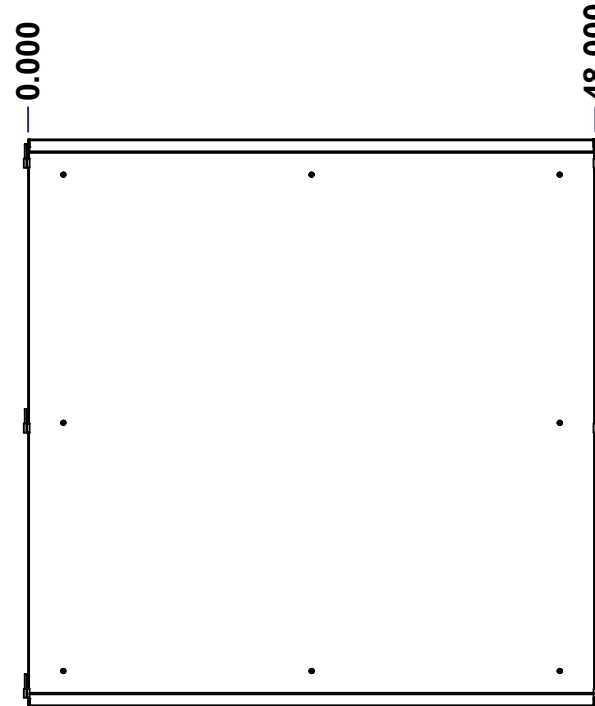

FRONT

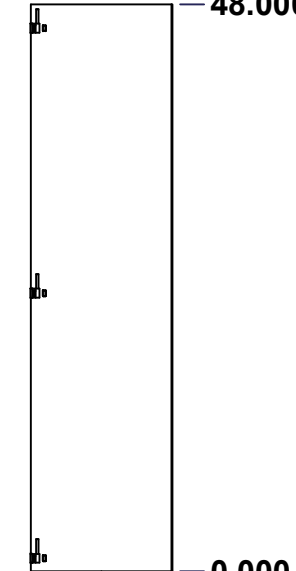

RIGHT



BOTTOM

No.	Revisions	Date	By/Par

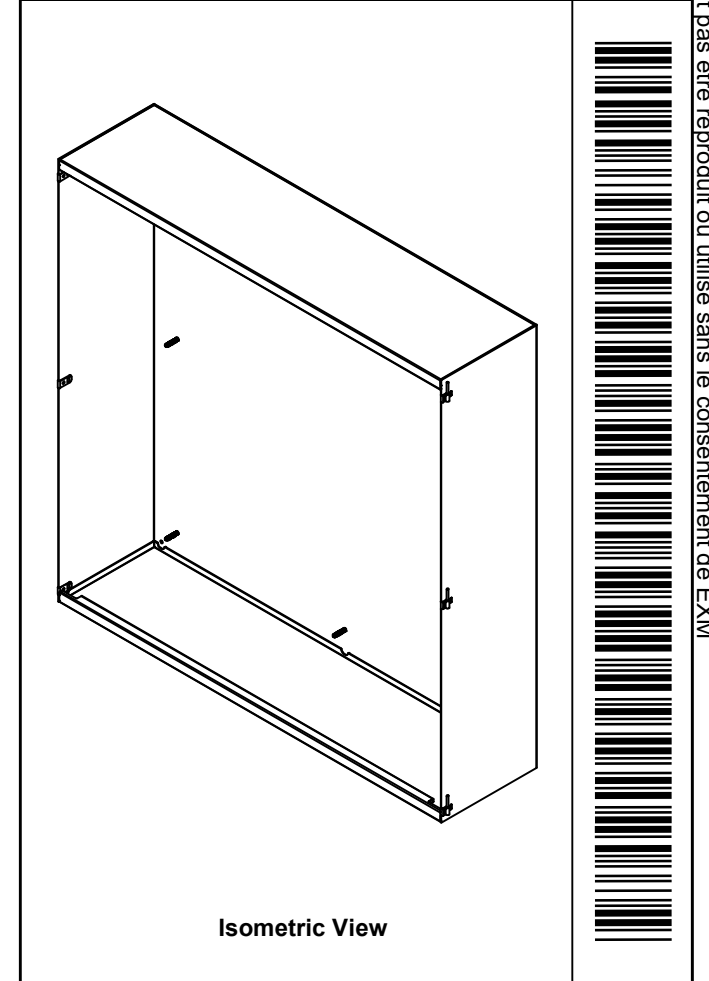

Isometric View

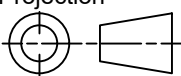
 Tél: (450) 979-4373 Fax: (450) 979-4626 www.exmweb.com		Flatness Aplatissement Max 3.0mm Projection 
Customer Client	Date	
Drawn By Dessiné Par	BoxCad: BoxCad	Date 06-Jun-23
Material Matière	14 Ga Cold Rolled A1008 CS Type B (1.7mm)	
Color Couleur	Asa-61 Grey	Finish Fini Smooth
Description	Detail Rev.	
1100CCDD 48" x 48" x 12" Body		
Part Number Numéro Pièce	Rev.	3
1100CCDD484812B	0	12

SEE BILL OF MATERIAL ON LAST PAGE

This drawing is confidential and must not be reproduced or used without the consent of EXM

Ce dessin est confidentiel et ne doit pas être reproduit ou utilisé sans le consentement de EXM

STANDARD FEATURES ARE NOT LISTED IN THIS HOLE TABLE

HOLE TABLE - BACK VIEW (CUSTOM FEATURE ONLY)

CUT-OUT	XDIM	YDIM	DESCRIPTION
1	3.000	3.000	IP STUD M8 x 35mm (Inside)
2	3.000	45.000	IP STUD M8 x 35mm (Inside)
3	45.000	45.000	IP STUD M8 x 35mm (Inside)
4	45.000	3.000	IP STUD M8 x 35mm (Inside)
5	3.000	24.000	IP STUD M8 x 35mm (Inside)
6	45.000	24.000	IP STUD M8 x 35mm (Inside)
7	24.000	3.000	IP STUD M8 x 35mm (Inside)
8	24.000	45.000	IP STUD M8 x 35mm (Inside)

9	1.000	1.000	RND Ø0.290
10	1.000	47.000	RND Ø0.290
11	47.000	1.000	RND Ø0.290
12	47.000	47.000	RND Ø0.290

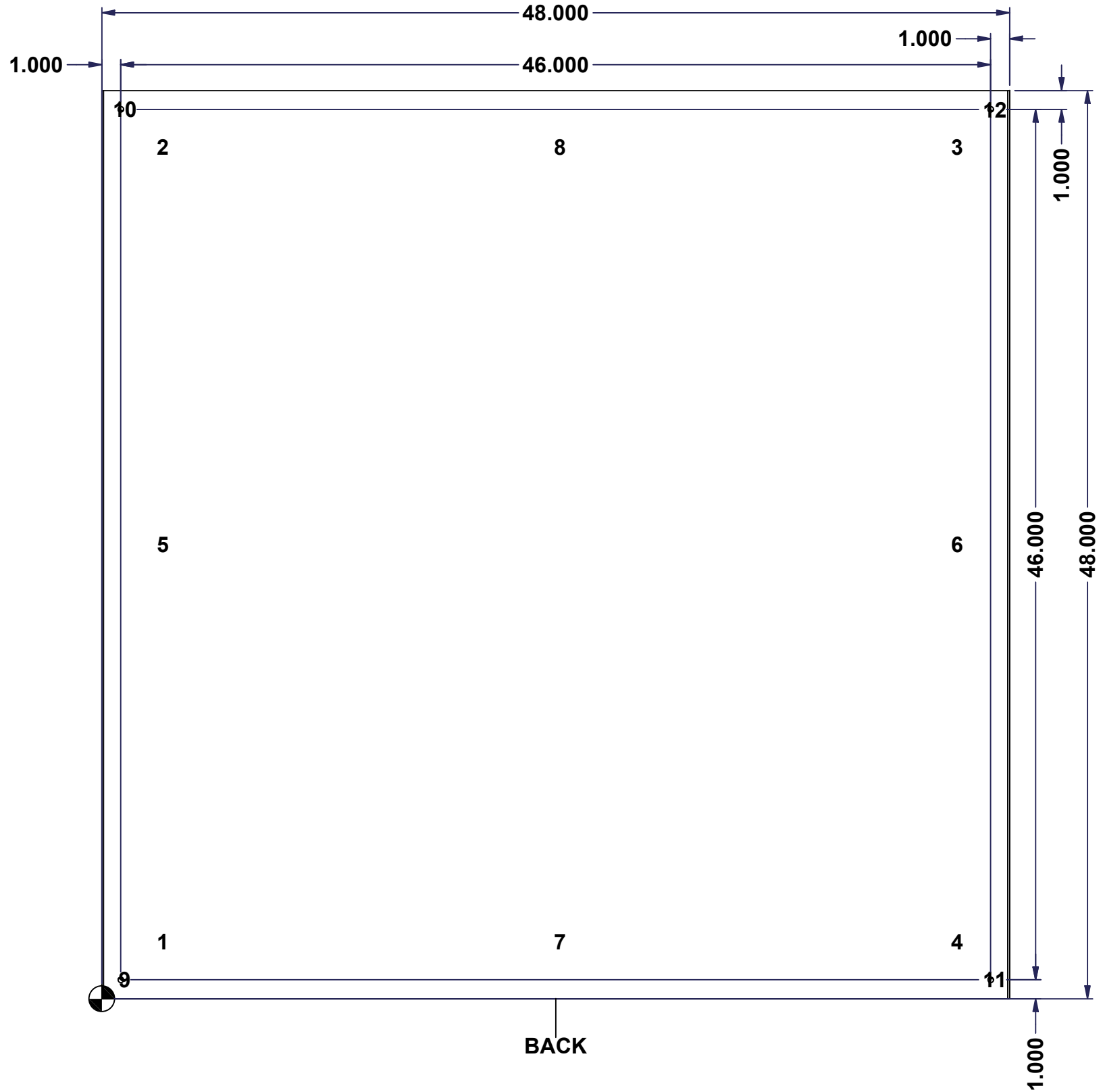

	Description	Status
	1100CCDD 48" x 48" x 12" Body	(NULL)
Part Number Numéro Pièce 1100CCDD484812B	Rev.	4
	0	12

This drawing is confidential and must not be reproduced or used without the consent of EXM

Ce dessin est confidentiel et ne doit pas être reproduit ou utilisé sans le consentement de EXM

No.	Revisions	Date	By/Par

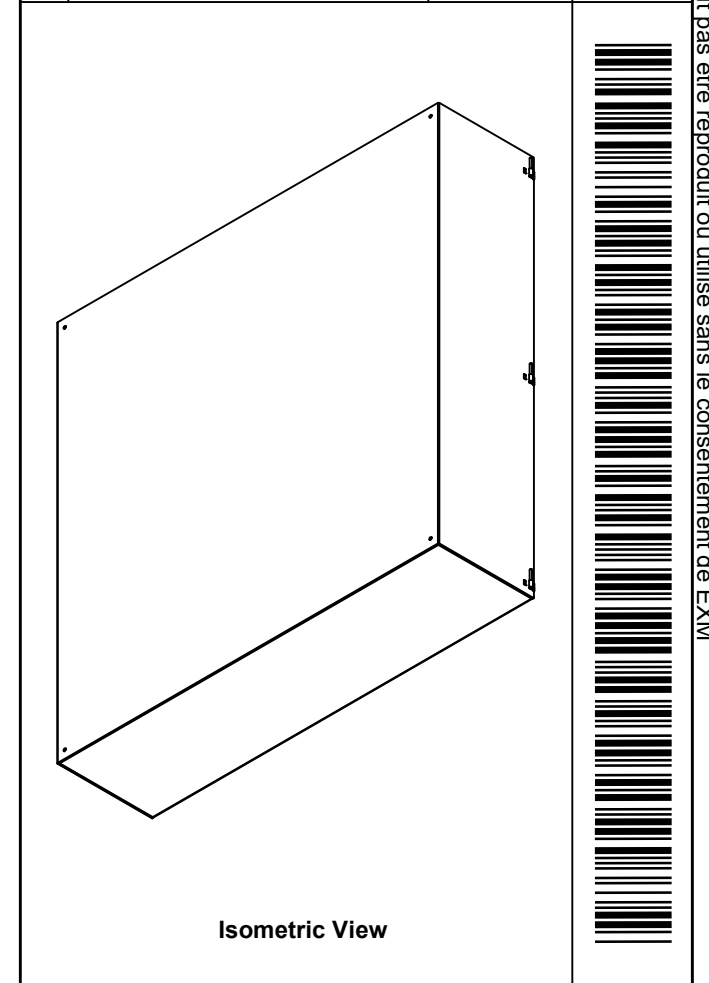

Isometric View

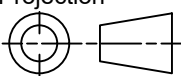

 Tél: (450) 979-4373 Fax: (450) 979-4626 www.exmweb.com		Flatness Aplatissement Max 3.0mm Projection 
Customer Client	Date	
Drawn By Dessiné Par	BoxCad: BoxCad	Date 06-Jun-23
Material Matière	14 Ga Cold Rolled A1008 CS Type B (1.7mm)	
Color Couleur	Asa-61 Grey	Finish Fini Smooth
Description		Detail Rev.
1100CCDD 48" x 48" x 12" Body		
Part Number Numéro Pièce	Rev.	5
1100CCDD484812B	0	12

Qty	Part Number	Rev	Description
1	STK-P-02400S	0	Powder Paint (Asa-61 Grey / Smooth)
8	STK-Q-16005	1	Stud M8 x 35mm (No Paint Cap Required)
3	STK-A-33410	7	1100 MC Left Side Hinge Assembly
3	STK-A-33510	7	1100 MC Right Side Hinge Part
1	1100CCDD484812T-P	0	1100CCDD 48" x 48" x 12" Top Part
1	1100CCDD484812BT-P	0	1100CCDD 48" x 48" x 12" Bottom Part
1	1100CCDD484812B-P	0	1100CCDD 48" x 48" x 12" Body Part
Parts List			

This drawing is confidential and must not be reproduced or used without the consent of EXM

Ce dessin est confidentiel et ne doit pas être reproduit ou utilisé sans le consentement de EXM

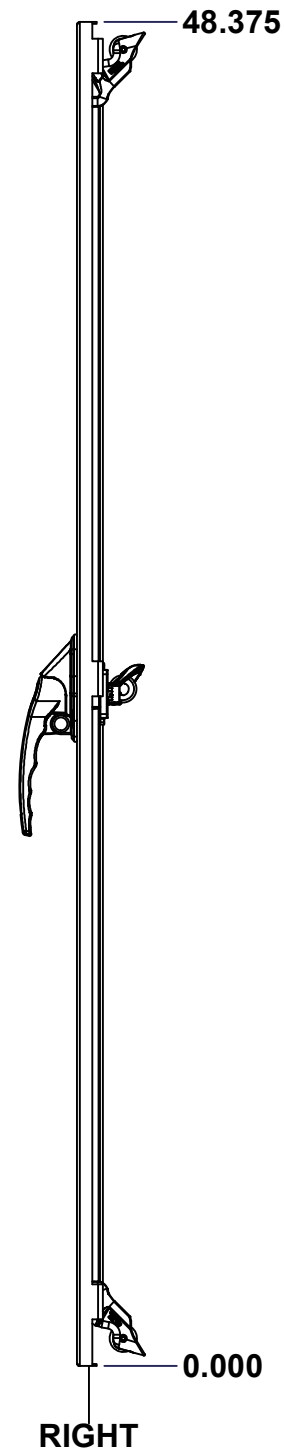
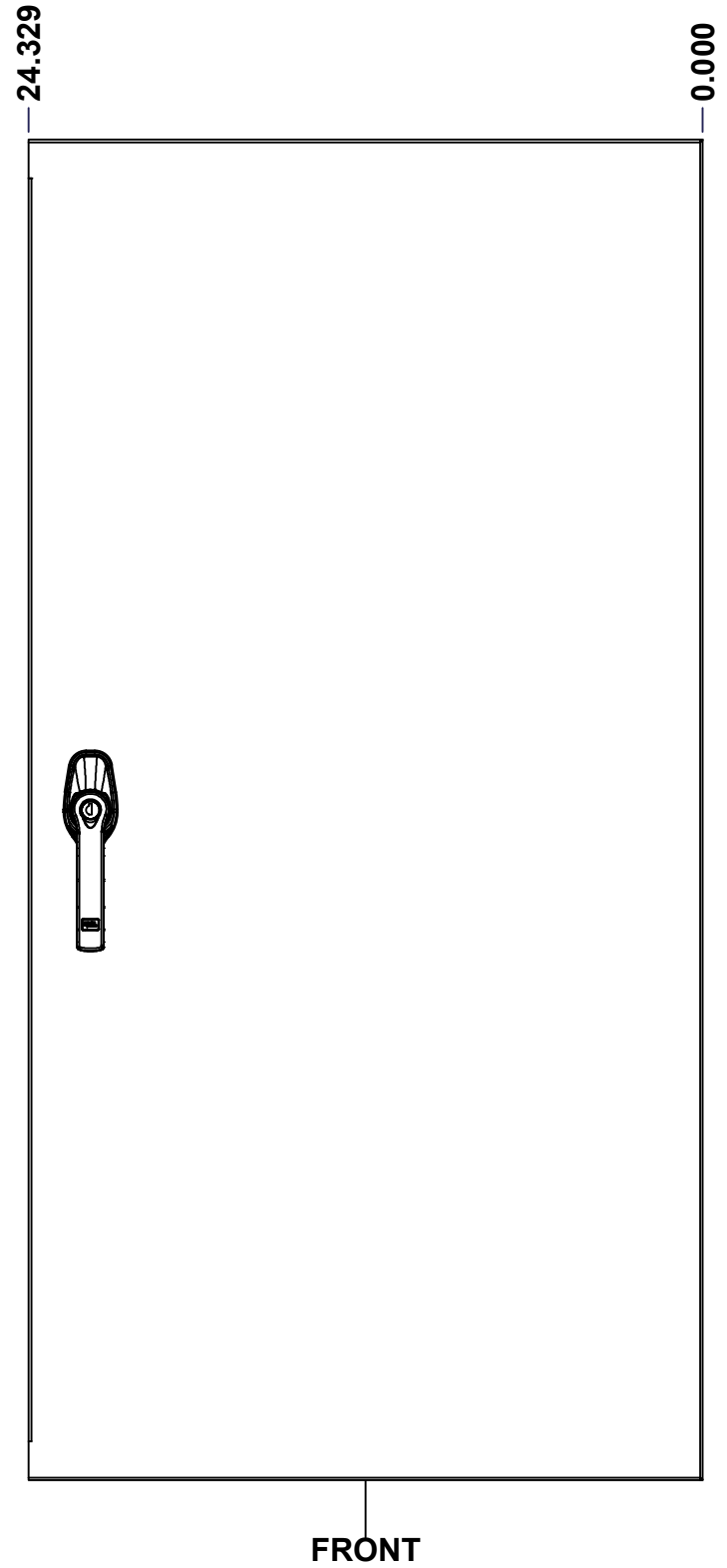
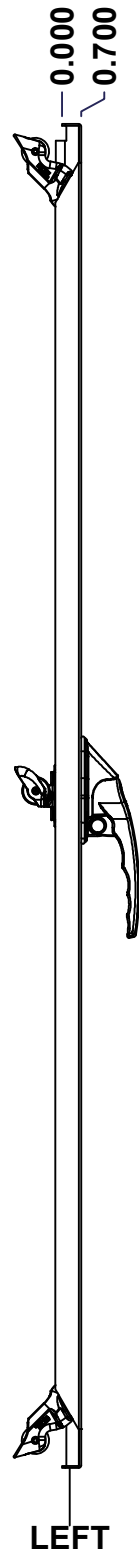
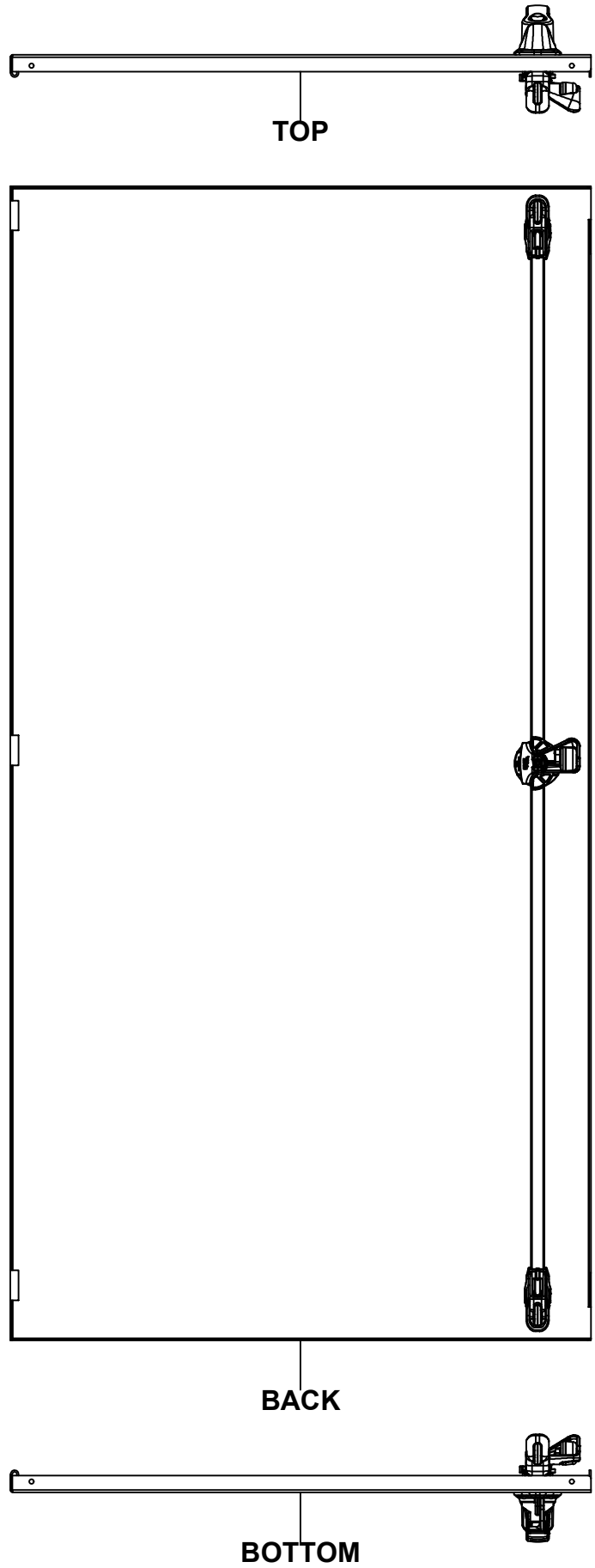

No.	Revisions	Date	By/Par

Isometric View

Tél: (450) 979-4373 Fax: (450) 979-4626 www.exmweb.com		Flatness Aplatissement
		Max 3.0mm
Projection 		Date
Customer Client	BoxCad: BoxCad	Date
Drawn By Dessiné Par	BoxCad: BoxCad	06-Jun-23
Material Matière	14 Ga Cold Rolled A1008 CS Type B (1.7mm)	
Color Couleur	Asa-61 Grey	Finish Fini: Smooth
Description	Detail Rev.	
1100CCDD 48" x 48" Cover		
Part Number Numéro Pièce	Rev. 6	12
1100CCDD484812LD		0

SEE BILL OF MATERIAL ON LAST PAGE

This drawing is confidential and must not be reproduced or used without the consent of EXM

Ce dessin est confidentiel et ne doit pas être reproduit ou utilisé sans le consentement de EXM

STANDARD FEATURES ARE NOT LISTED IN THIS HOLE TABLE

HOLE TABLE - FRONT VIEW (CUSTOM FEATURE ONLY)

CUT-OUT	XDIM	YDIM	DESCRIPTION
1	22.100	43.468	CLOSING BAR STUD (Inside)
2	22.100	4.907	CLOSING BAR STUD (Inside)
-----	-----	-----	-----
3	22.100	24.188	HANDLE 885 ESL2A-APHK @ 0.0°

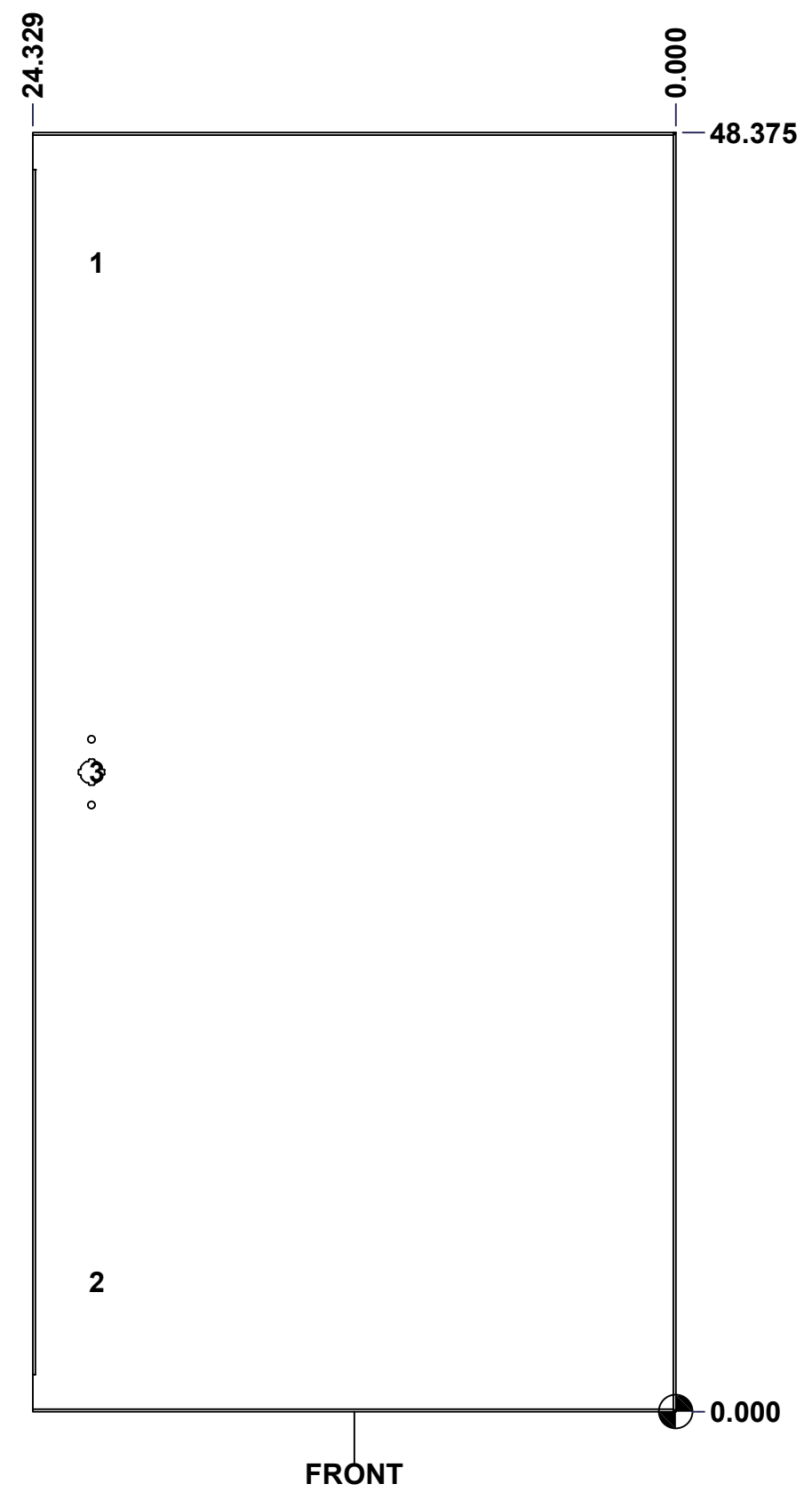

	Description	Status
	1100CCDD 48" x 48" Cover	(NULL)
	Part Number Numéro Pièce	Rev.
	1100CCDD484812LD	0 / 7
		12

This drawing is confidential and must not be reproduced or used without the consent of EXM

Ce dessin est confidentiel et ne doit pas être reproduit ou utilisé sans le consentement de EXM

No.	Revisions	Date	By/Par

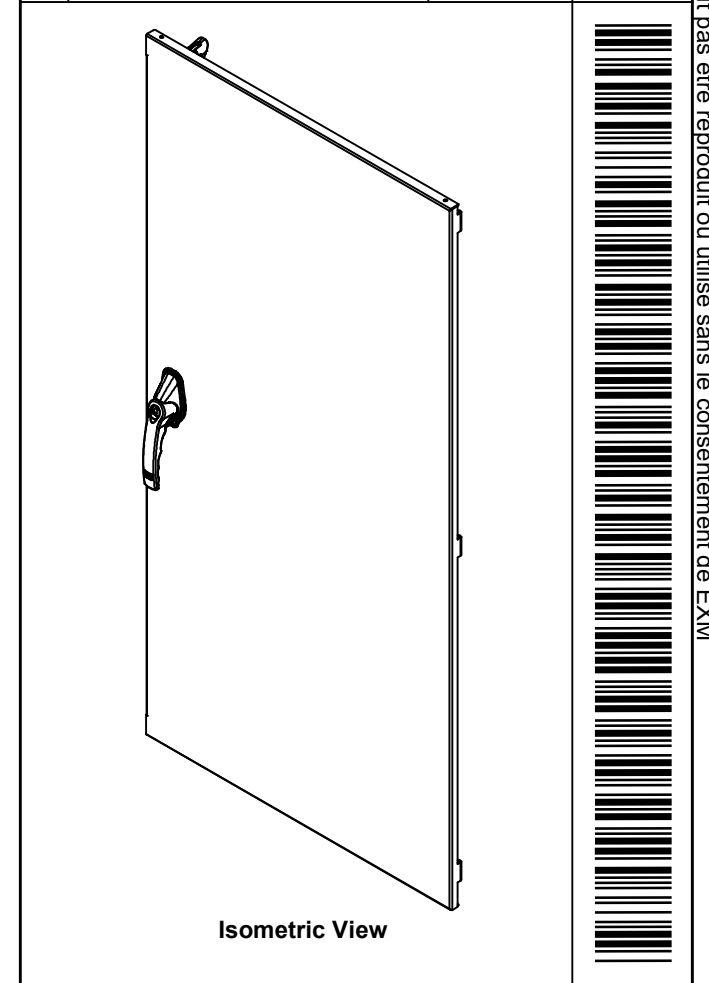

EXM
www.exmweb.com

Tél: (450) 979-4373
Fax: (450) 979-4626

Flatness
Aplatissement
Max 3.0mm

Projection

Customer Client _____ Date _____

Drawn By / Dessiné Par BoxCad: BoxCad Date 06-Jun-23

Material / Matière 14 Ga Cold Rolled A1008 CS Type B (1.7mm)

Color / Couleur Asa-61 Grey Finish / Fini Smooth

Description 1100CCDD 48" x 48" Cover Detail Rev. _____

Part Number / Numéro Pièce **1100CCDD484812LD** Rev. **0** 8 / 12

QTY	Part Number	Rev	Description
2	STK-Q-07220	1	M6 Nylon Insert Lock Nut
2	STK-A-90042	5	5412 ES Cabinet Closing Bar End Assembly
2	STK-Q-45655-48	0	5412 ES - Closing Bar
1	STK-A-50535	15	5412 ES Handle Cam Assembly (Left Side, Grip 32mm)
1	STK-Q-90051	3	5412 ES - Handle Cam Spacer
1	885ESL2A-APHK	7	885 ESL2A-APHK - Zinc Die Cast L-Handle Padlockable Assy
1	STK-P-02400S	0	Powder Paint (Asa-61 Grey / Smooth)
2	STK-Q-16405	7	Guide Stud - Small (No Paint Cap Required)
1	1100CCDD484812LD-P	0	1100CCDD 48" x 48" x 12" Flange Cover Part
Parts List			

This drawing is confidential and must not be reproduced or used without the consent of EXM

Ce dessin est confidentiel et ne doit pas être reproduit ou utilisé sans le consentement de EXM

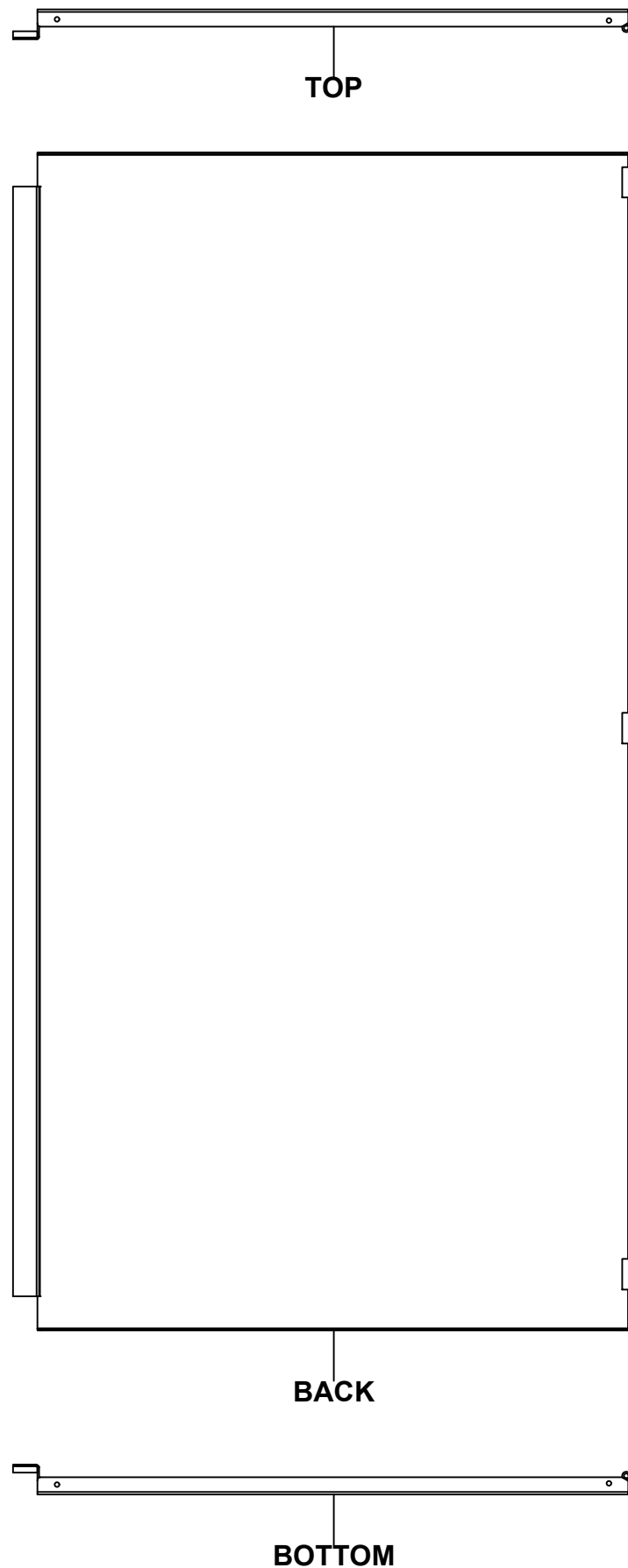

No.	Revisions	Date	By/Par

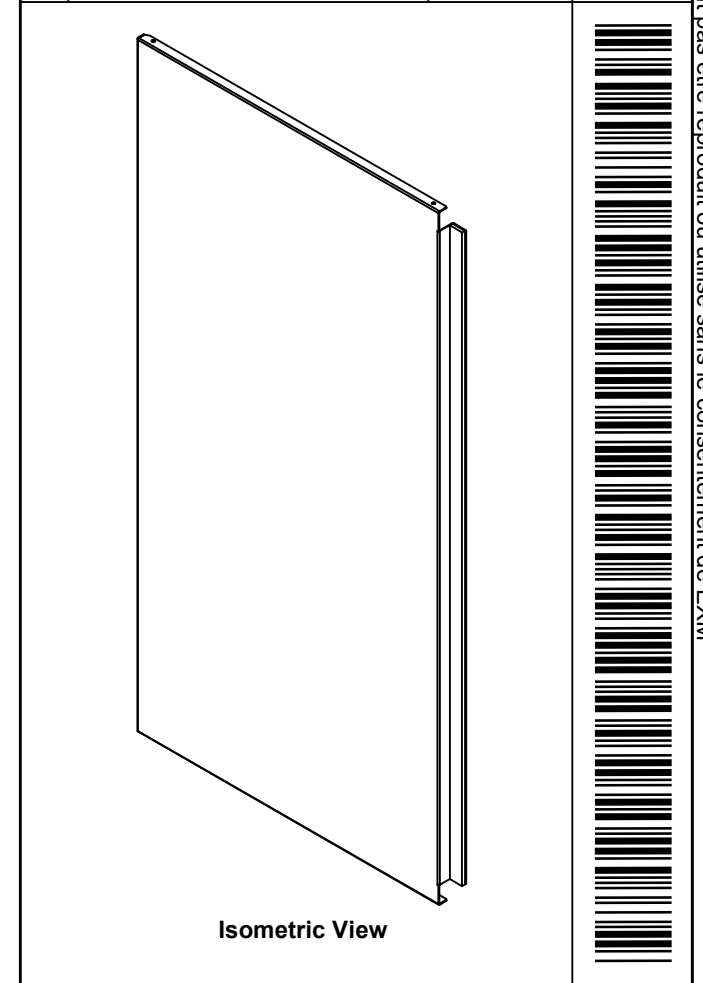

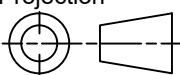
 Tél: (450) 979-4373 Fax: (450) 979-4626 www.exmweb.com		Flatness Aplatissement Max 3.0mm Projection 
Customer Client	Date	
Drawn By Dessiné Par	BoxCad: BoxCad	Date 06-Jun-23
Material Matière	14 Ga Cold Rolled A1008 CS Type B (1.7mm)	
Color Couleur	Asa-61 Grey	Finish Fini Smooth
Description 1100CCDD 48" x 48" Cover		Detail Rev.
Part Number Numéro Pièce	Rev. 0	9 12

SEE BILL OF MATERIAL ON LAST PAGE

1100CCDD484812FD

This drawing is confidential and must not be reproduced or used without the consent of EXM

Ce dessin est confidentiel et ne doit pas être reproduit ou utilisé sans le consentement de EXM

No.	Revisions	Date	By/Par

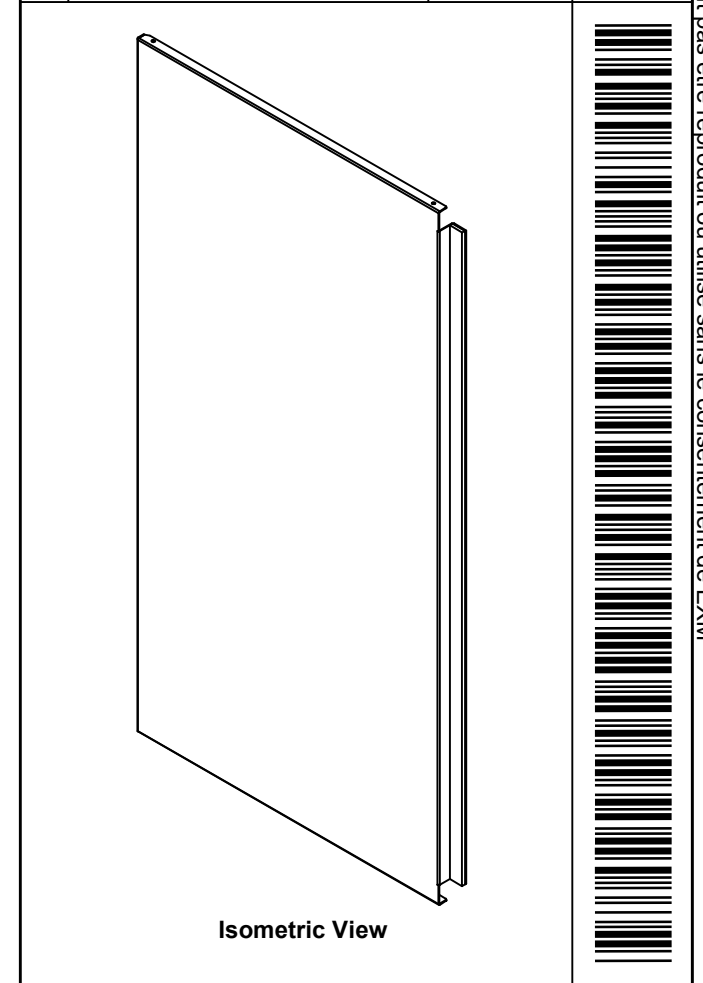

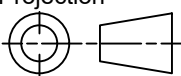
 Tél: (450) 979-4373 Fax: (450) 979-4626 www.exmweb.com		Flatness Aplatissement Max 3.0mm Projection 
Customer Client	Date	
Drawn By Dessiné Par	BoxCad: BoxCad	Date 06-Jun-23
Material Matière	14 Ga Cold Rolled A1008 CS Type B (1.7mm)	
Color Couleur	Asa-61 Grey	Finish Fini Smooth
Description		Detail Rev.
1100CCDD 48" x 48" Cover		
Part Number Numéro Pièce	Rev.	10
1100CCDD484812FD	0	12

QTY	Part Number	Rev	Description
1	STK-P-02400S	0	Powder Paint (Asa-61 Grey / Smooth)
1	STK-G-00701	0	1" x 1/4" Self-Adhesive Neoprene Gasket
1	1100CCDD484812FD-P	0	1100CCDD 48" x 48" x 12" Lock Cover Part
Parts List			

This drawing is confidential and must not be reproduced or used without the consent of EXM

Ce dessin est confidentiel et ne doit pas être reproduit ou utilisé sans le consentement de EXM

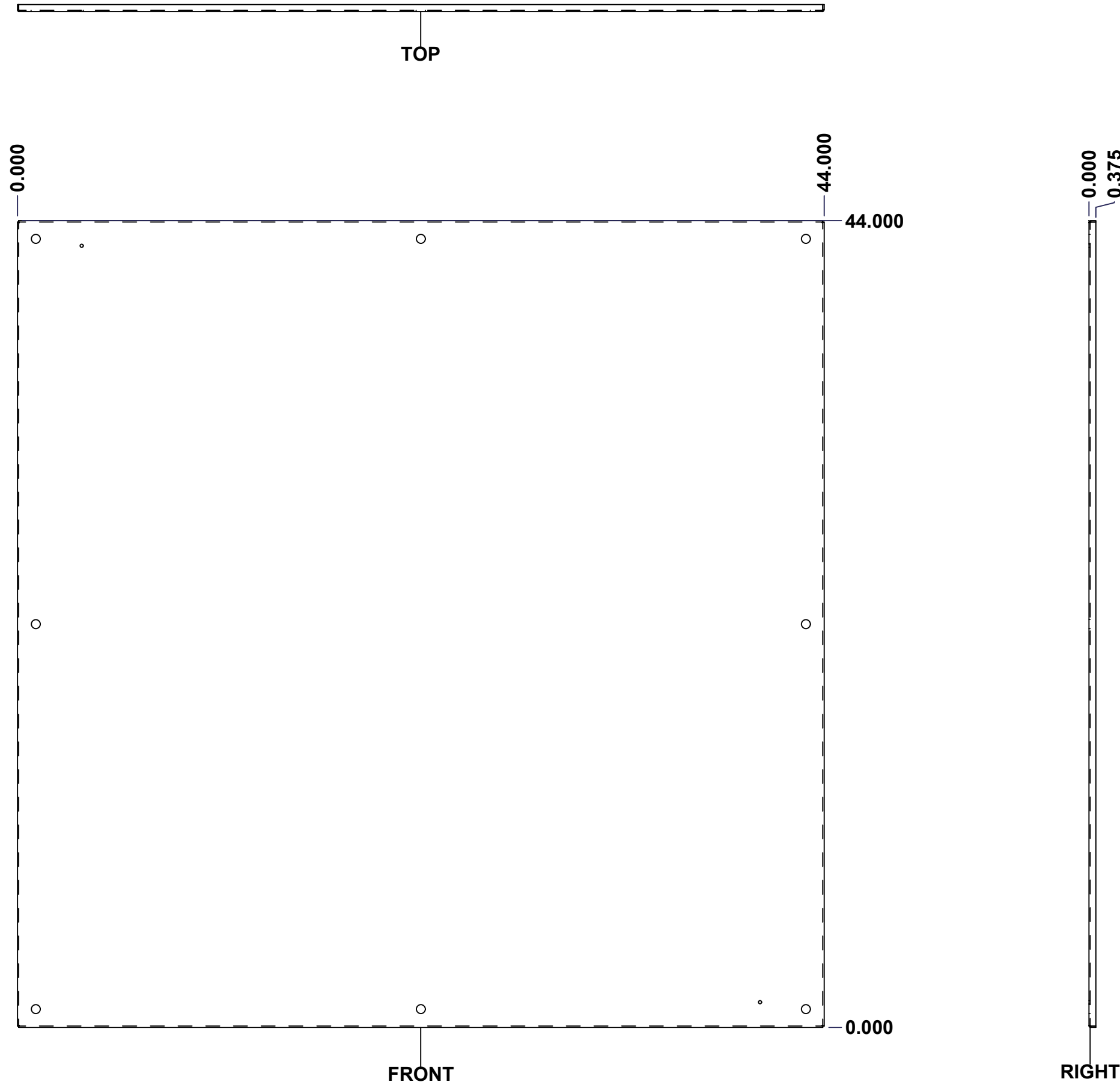

No.	Revisions	Date	By/Par

Isometric View

Tél: (450) 979-4373 Fax: (450) 979-4626 www.exmweb.com		Flatness Aplatissement	
		Max 3.0mm	
Customer Client		Date	
Drawn By Dessiné Par		Date	
Material Matière		Date	
Color Couleur		Date	
Description		Detail Rev.	
Part Number Numéro Pièce		Rev.	

BoxCad: BoxCad 06-Jun-23

14 Ga Galvanized (1.7mm)

Unpainted Unpainted

1100CCDD 48" x 48" Inner Panel

1100CCDD484812IP 0 11/12

SEE BILL OF MATERIAL ON LAST PAGE

This drawing is confidential and must not be reproduced or used without the consent of EXM

Ce dessin est confidentiel et ne doit pas être reproduit ou utilisé sans le consentement de EXM

No.	Revisions	Date	By/Par

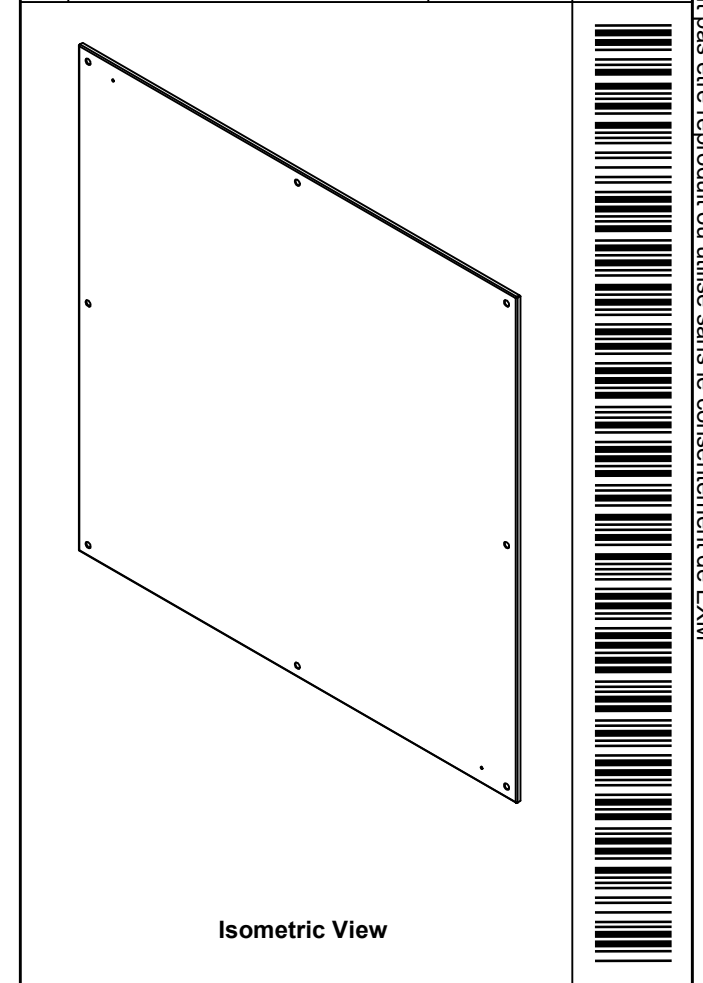

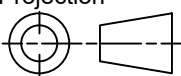
 Tél: (450) 979-4373 Fax: (450) 979-4626 www.exmweb.com		Flatness Aplatissement Max 3.0mm
Customer Client		Projection 
Drawn By / Dessiné Par: BoxCad: BoxCad		Date: 06-Jun-23
Material / Matière: 14 Ga Galvanized (1.7mm)		
Color / Couleur: Unpainted	Finish / Fini: Unpainted	
Description: 1100CCDD 48" x 48" Inner Panel		Detail Rev.
Part Number / Numéro Pièce: 1100CCDD484812IP		Rev. 0 / 12

Qty	Part Number	Rev	Description
1	1100CCDD484812IP-P	0	1100CCDD 48" x 48" Inner Panel Part
Parts List			