

This drawing is confidential and must not be reproduced or used without the consent of EXM

Ce dessin est confidentiel et ne doit pas être reproduit ou utilisé sans le consentement de EXM

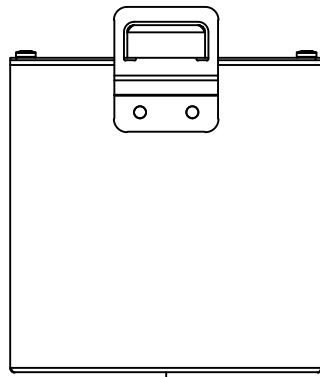

TOP

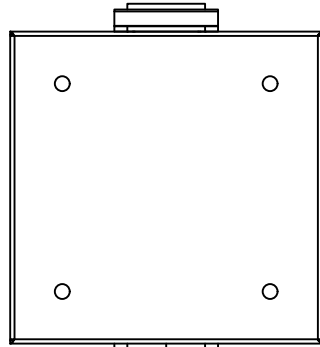

BACK

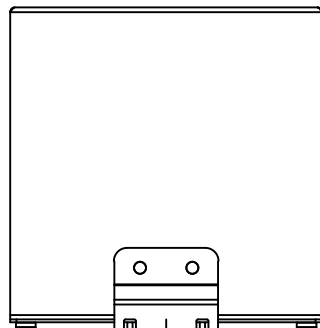

BOTTOM

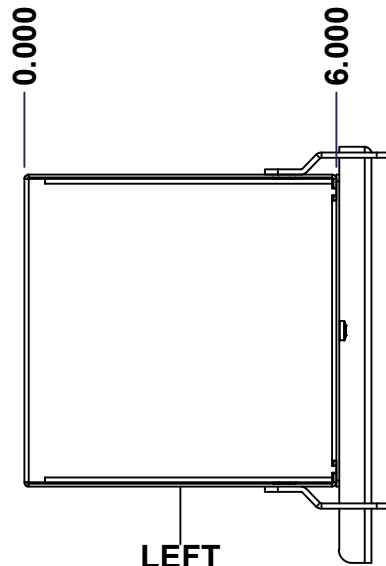

LEFT

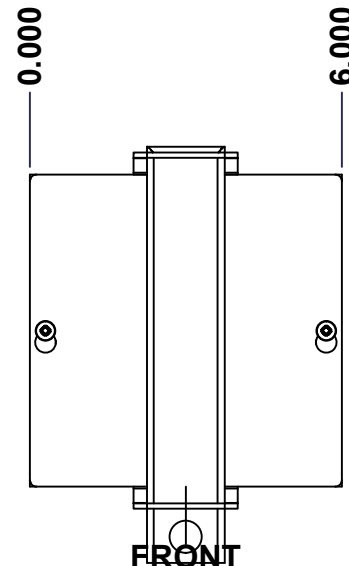

FRONT

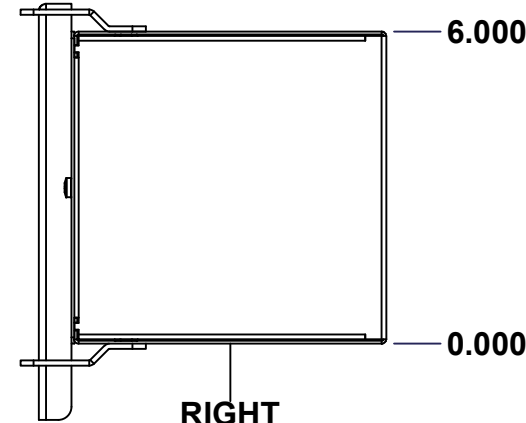

RIGHT

| No. | Revisions | Date | By/Par |
|-----|-----------|------|--------|
| | | | |
| | | | |
| | | | |
| | | | |

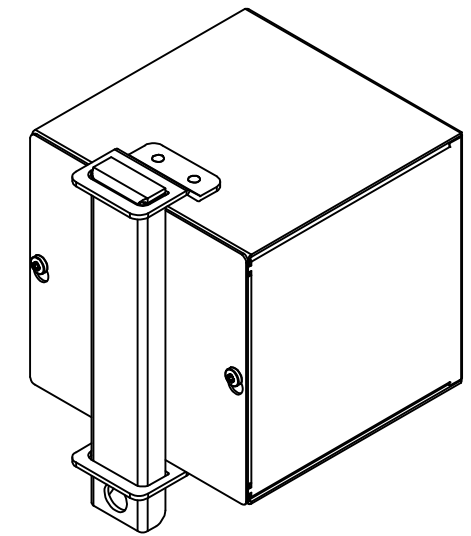

Isometric View



Tél: (450) 979-4373
 Fax: (450) 979-4626
www.exmweb.com

Flatness
Aplatissement

Max 3.0mm

Projection



| | |
|---|-----------------|
| Customer Client | Date |
| Drawn By / Dessiné Par: BoxCad: BoxCad | Date: 18-Jul-22 |
| Material / Matière: 16 Ga Cold Rolled A1008 CS Type B (1.4mm) | |

| | |
|------------------------------|-----------------------|
| Color / Couleur: Asa-61 Grey | Finish / Fini: Smooth |
|------------------------------|-----------------------|

| | |
|---|-------------|
| Description: 1100DFPN 6" x 6" x 6" Assembly | Detail Rev. |
|---|-------------|

| | | | |
|--|--------|---|----|
| Part Number / Numéro Pièce: 1100DFP060606N | Rev. 0 | 1 | 10 |
|--|--------|---|----|

SEE BILL OF MATERIAL ON LAST PAGE

This drawing is confidential and must not be reproduced or used without the consent of EXM

Ce dessin est confidentiel et ne doit pas être reproduit ou utilisé sans le consentement de EXM

| NOTE | |
|------|--|
| ITEM | DESCRIPTION |
| 1 | NEMA 1 Enclosure (IP20) |
| 2 | C/W Standard ground provision on box and cover |
| 3 | W/O Standard door stiffener |
| 4 | W/O Inner panel |
| 5 | W/O Inner panel mounting provision |
| 6 | C/W Padlock Kit (Not Installed) |

| No. | Revisions | Date | By/Par |
|-----|-----------|------|--------|
| | | | |
| | | | |
| | | | |
| | | | |
| | | | |
| | | | |

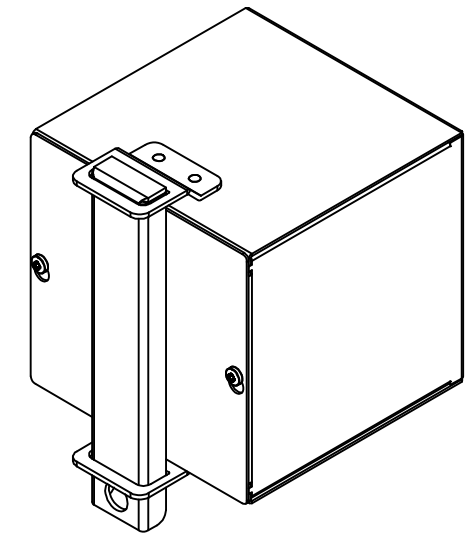

Isometric View

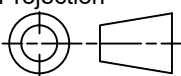
| | | |
|--|---|---|
|  Tél: (450) 979-4373 Fax: (450) 979-4626 www.exmweb.com | Flatness Aplatissement | Max 3.0mm |
| | Projection |  |
| Customer Client | Date | |
| Drawn By Dessiné Par | BoxCad: BoxCad | Date 18-Jul-22 |
| Material Matière | 16 Ga Cold Rolled A1008 CS Type B (1.4mm) | |
| Color Couleur | Asa-61 Grey | Finish Fini Smooth |
| Description | Detail Rev. | |
| 1100DFPN 6" x 6" x 6" Assembly | | |
| Part Number Numéro Pièce | Rev. 0 | 2 / 10 |
| 1100DFP060606N | | |

| PACKING | | |
|----------------------|-----|---|
| ITEM | QTY | DESCRIPTION |
| Thermal plastic film | 1 | Use with Packing Tunnel Wrapper Machine |
| Packaging label | 1 | White label with product number |

| Qty | Part Number | Rev | Description |
|-----|-----------------|-----|-------------------------------|
| 1 | 880 DPF06 | 0 | 880 DFP Padlock Kit |
| 2 | STK-Q-05020 | 5 | M5 x 8mm Thread Rolling Screw |
| 1 | 1100DFP060606NC | 0 | 1100DFPN 6" x 6" Cover |
| 1 | 1100DFP060606NB | 0 | 1100DFPN 6" x 6" x 6" Body |

Parts List

This drawing is confidential and must not be reproduced or used without the consent of EXM

Ce dessin est confidentiel et ne doit pas être reproduit ou utilisé sans le consentement de EXM

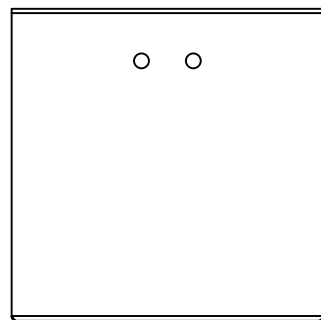

TOP

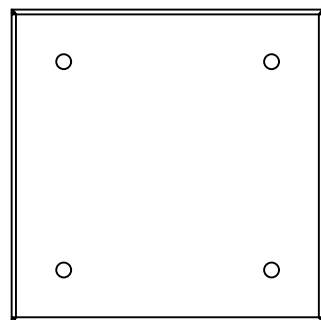

BACK

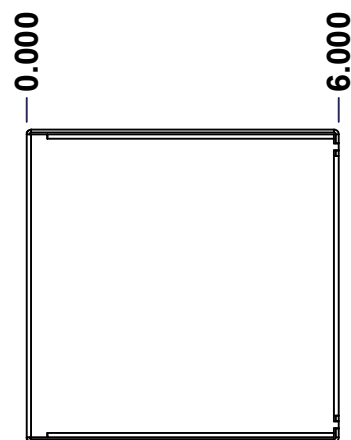

LEFT

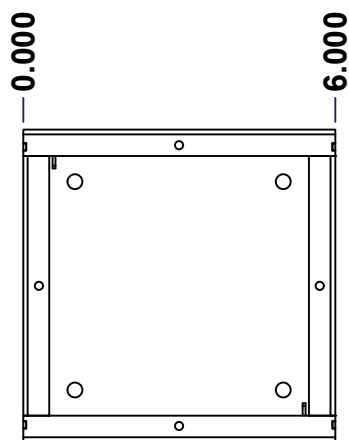

FRONT

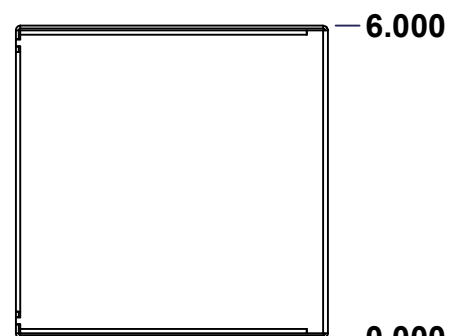

RIGHT

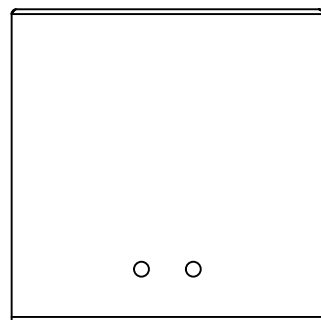

BOTTOM

| No. | Revisions | Date | By/Par |
|-----|-----------|------|--------|
| | | | |
| | | | |
| | | | |
| | | | |
| | | | |

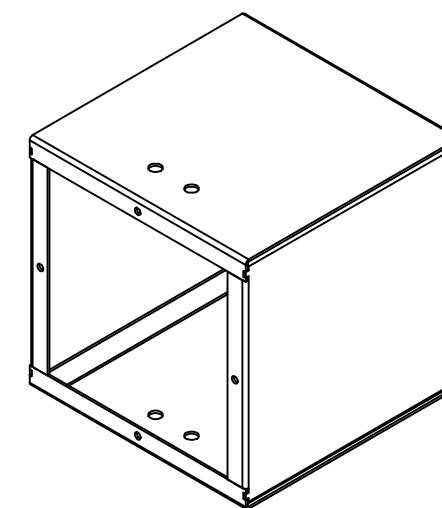

Isometric View



Tél: (450) 979-4373
 Fax: (450) 979-4626
www.exmweb.com

Flatness
Aplatissement

Max 3.0mm

Projection



| | |
|---|-----------------|
| Customer Client | Date |
| Drawn By / Dessiné Par: BoxCad: BoxCad | Date: 18-Jul-22 |
| Material / Matière: 16 Ga Cold Rolled A1008 CS Type B (1.4mm) | |

| | |
|------------------------------|-----------------------|
| Color / Couleur: Asa-61 Grey | Finish / Fini: Smooth |
|------------------------------|-----------------------|

| | |
|---|-------------|
| Description: 1100DFPN 6" x 6" x 6" Body | Detail Rev. |
|---|-------------|

| | | | |
|---|--------|---|----|
| Part Number / Numéro Pièce: 1100DFP060606NB | Rev. 0 | 3 | 10 |
|---|--------|---|----|

SEE BILL OF MATERIAL ON LAST PAGE

This drawing is confidential and must not be reproduced or used without the consent of EXM

Ce dessin est confidentiel et ne doit pas être reproduit ou utilisé sans le consentement de EXM

| STANDARD FEATURES ARE NOT LISTED IN THIS HOLE TABLE | | | |
|---|-------|-------|-------------|
| HOLE TABLE - TOP VIEW (CUSTOM FEATURE ONLY) | | | |
| CUT-OUT | XDIM | YDIM | DESCRIPTION |
| 1 | 2.500 | 5.000 | RND Ø0.290 |
| 2 | 3.500 | 5.000 | RND Ø0.290 |

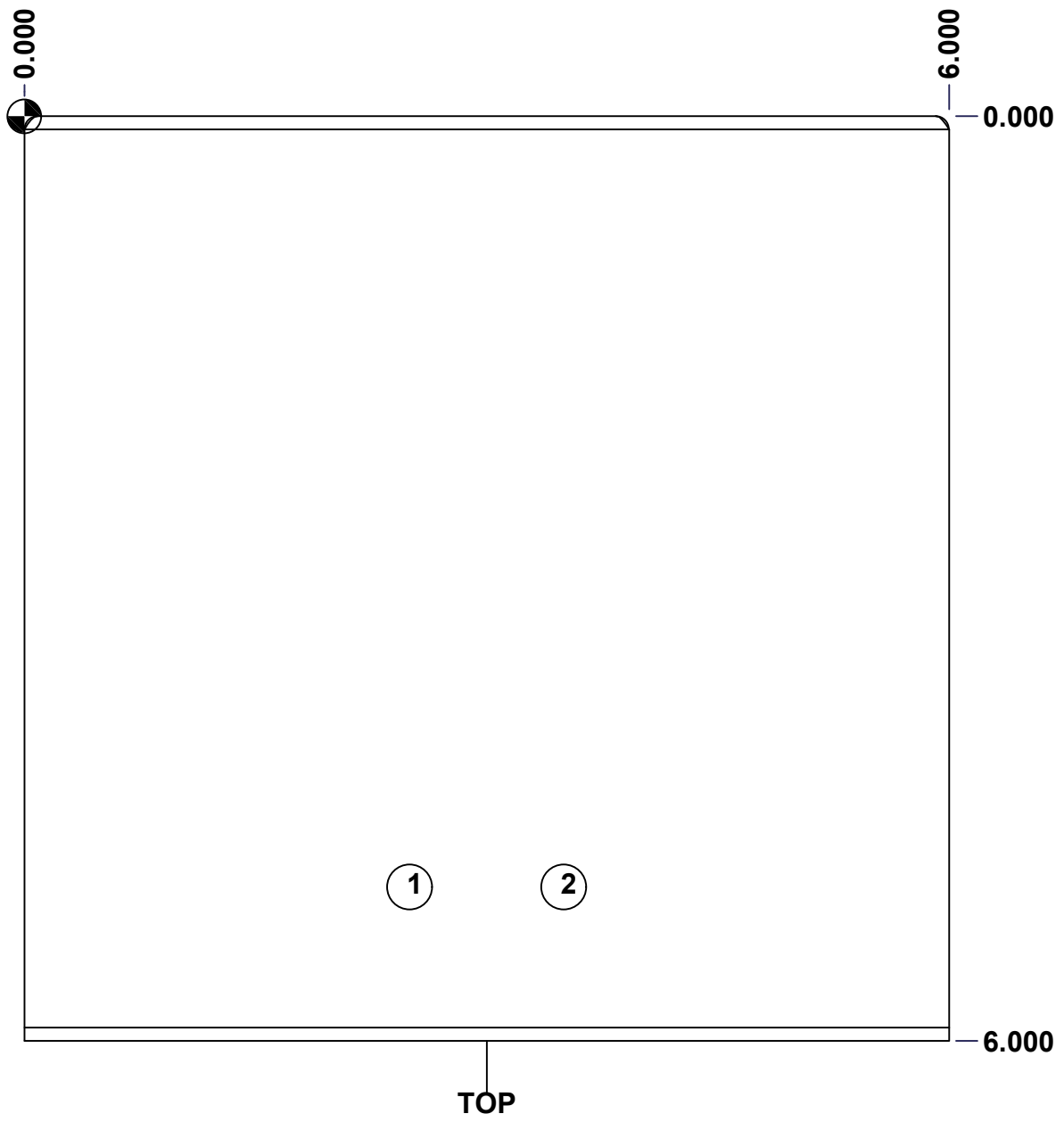

| | | |
|--|---|-------------------------|
| | Description 1100DFPN 6" x 6" x 6" Body | Status (NULL) |
| | Part Number Numéro Pièce 1100DFP060606NB | Rev. 4 0 / 10 |

This drawing is confidential and must not be reproduced or used without the consent of EXM

Ce dessin est confidentiel et ne doit pas être reproduit ou utilisé sans le consentement de EXM

| STANDARD FEATURES ARE NOT LISTED IN THIS HOLE TABLE | | | |
|---|-------|-------|-------------|
| HOLE TABLE - BOTTOM VIEW (CUSTOM FEATURE ONLY) | | | |
| CUT-OUT | XDIM | YDIM | DESCRIPTION |
| 1 | 2.500 | 5.000 | RND Ø0.290 |
| 2 | 3.500 | 5.000 | RND Ø0.290 |

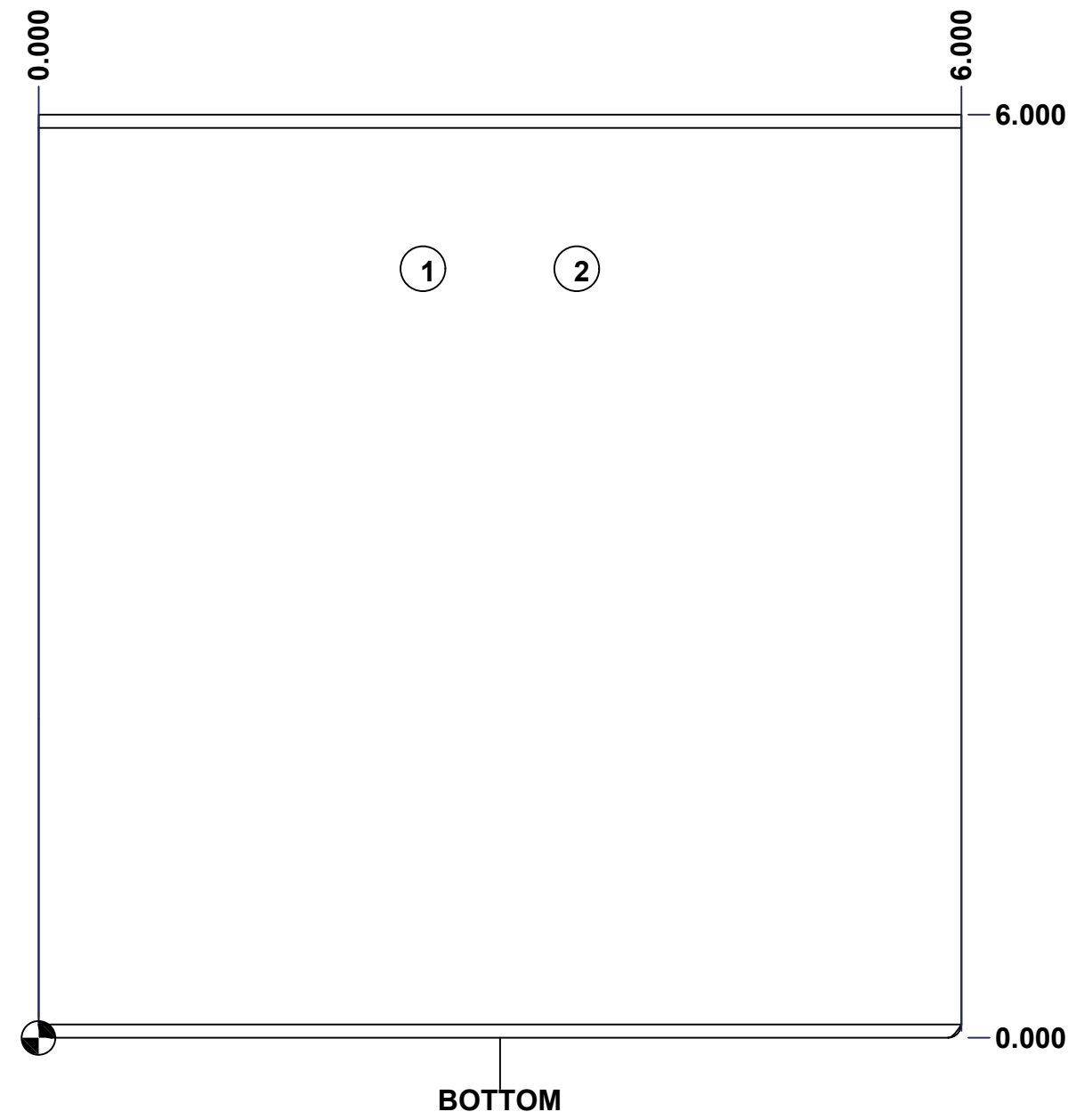

| | | | |
|--|-----------------------------|----------|----|
| | Description | Status | |
| | 1100DFPN 6" x 6" x 6" Body | (NULL) | |
| | Part Number Numéro Pièce | Rev. | 5 |
| | 1100DFP060606NB | 0 | 10 |

This drawing is confidential and must not be reproduced or used without the consent of EXM

Ce dessin est confidentiel et ne doit pas être reproduit ou utilisé sans le consentement de EXM

| STANDARD FEATURES ARE NOT LISTED IN THIS HOLE TABLE | | | |
|---|-------|-------|-------------|
| HOLE TABLE - BACK VIEW (CUSTOM FEATURE ONLY) | | | |
| CUT-OUT | XDIM | YDIM | DESCRIPTION |
| 1 | 5.000 | 1.000 | RND Ø0.290 |
| 2 | 5.000 | 5.000 | RND Ø0.290 |
| 3 | 1.000 | 5.000 | RND Ø0.290 |
| 4 | 1.000 | 1.000 | RND Ø0.290 |

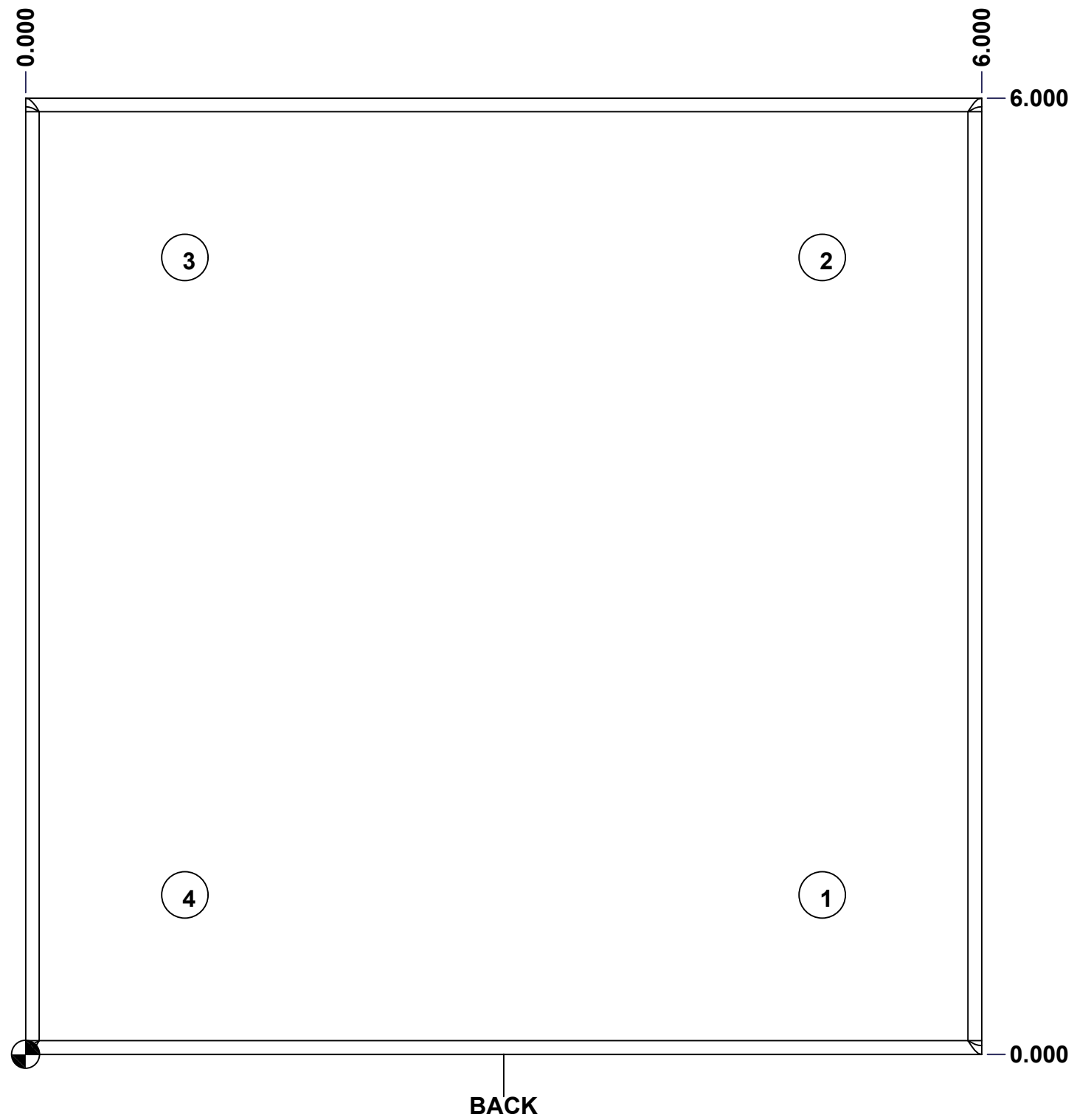

| | | |
|--|---|-------------------------|
| | Description 1100DFPN 6" x 6" x 6" Body | Status (NULL) |
| | Part Number Numéro Pièce 1100DFP060606NB | Rev. 6 0 / 10 |

This drawing is confidential and must not be reproduced or used without the consent of EXM

Ce dessin est confidentiel et ne doit pas être reproduit ou utilisé sans le consentement de EXM

| No. | Revisions | Date | By/Par |
|-----|-----------|------|--------|
| | | | |
| | | | |
| | | | |
| | | | |
| | | | |

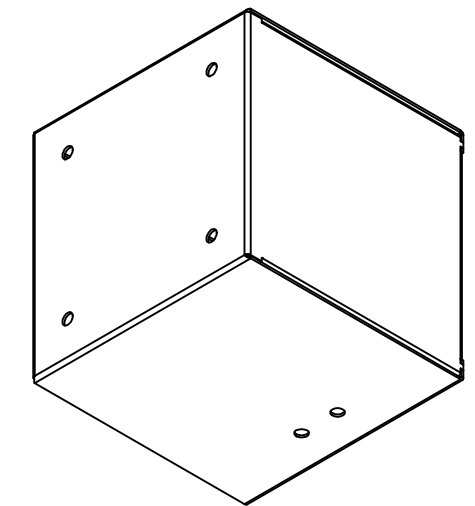

Isometric View

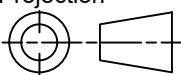

| | | |
|--|---|---|
|  Tél: (450) 979-4373 Fax: (450) 979-4626 www.exmweb.com | Flatness Aplatissement | Max 3.0mm |
| | Projection |  |
| Customer Client | Date | |
| Drawn By Dessiné Par | BoxCad: BoxCad | Date 18-Jul-22 |
| Material Matière | 16 Ga Cold Rolled A1008 CS Type B (1.4mm) | |
| Color Couleur | Asa-61 Grey | Finish Fini Smooth |
| Description | Detail Rev. | |
| 1100DFPN 6" x 6" x 6" Body | | |
| Part Number Numéro Pièce | Rev. 0 | 7/10 |
| 1100DFP060606NB | | |

| Qty | Part Number | Rev | Description |
|------------|-------------------|-----|-------------------------------------|
| 1 | STK-P-02400S | 0 | Powder Paint (Asa-61 Grey / Smooth) |
| 1 | 1100DFP060606NB-P | 0 | 1100DFPN 6" x 6" x 6" Body Part |
| Parts List | | | |

This drawing is confidential and must not be reproduced or used without the consent of EXM

Ce dessin est confidentiel et ne doit pas être reproduit ou utilisé sans le consentement de EXM

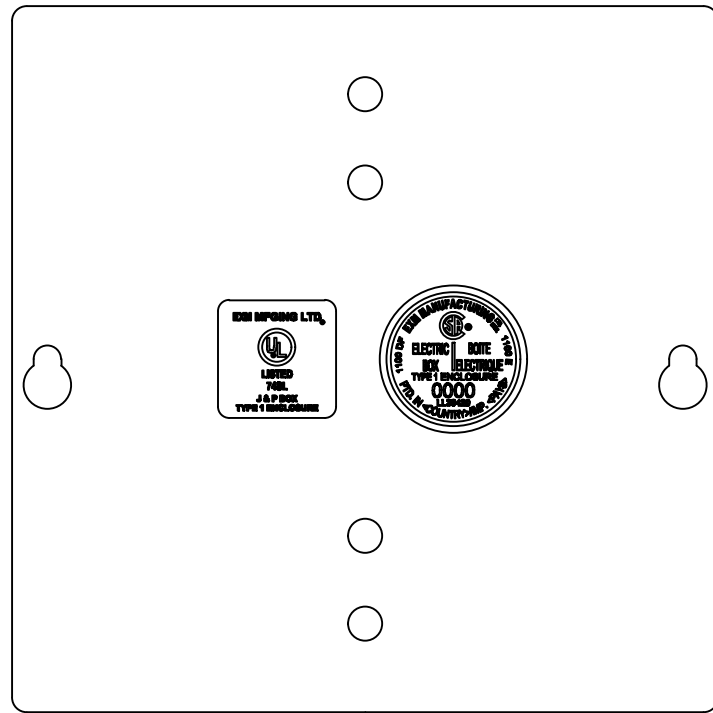
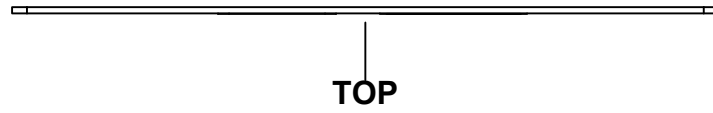

BACK

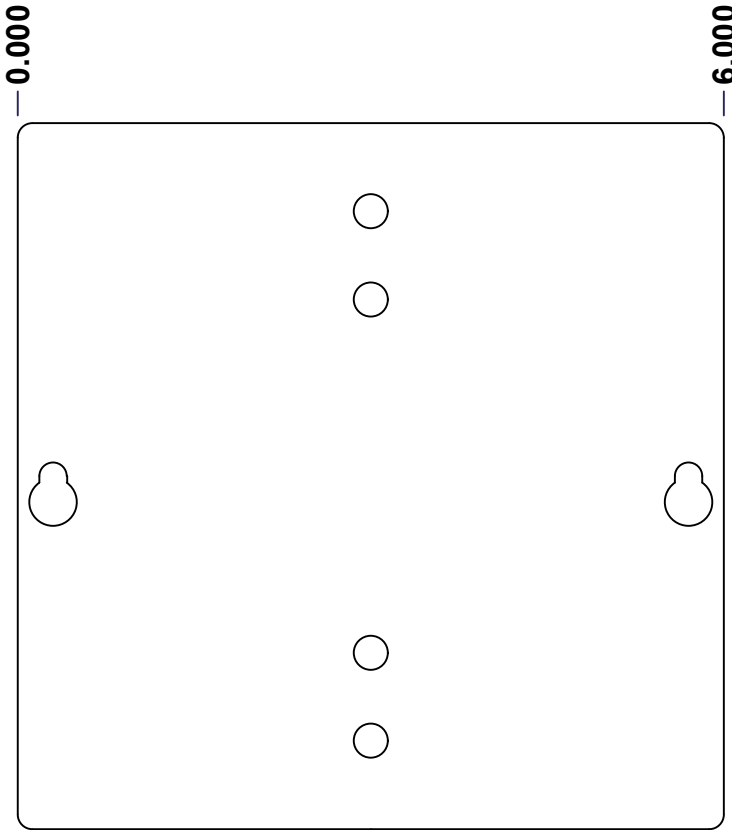
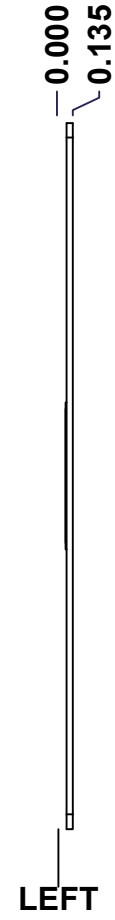

FRONT

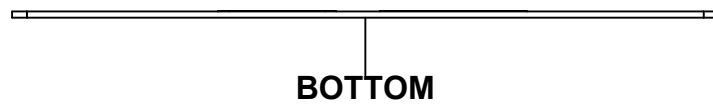
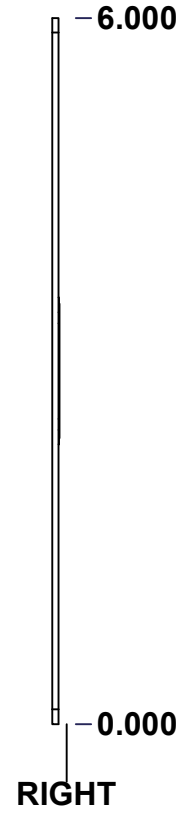

| No. | Revisions | Date | By/Par |
|-----|-----------|------|--------|
| | | | |
| | | | |
| | | | |
| | | | |
| | | | |

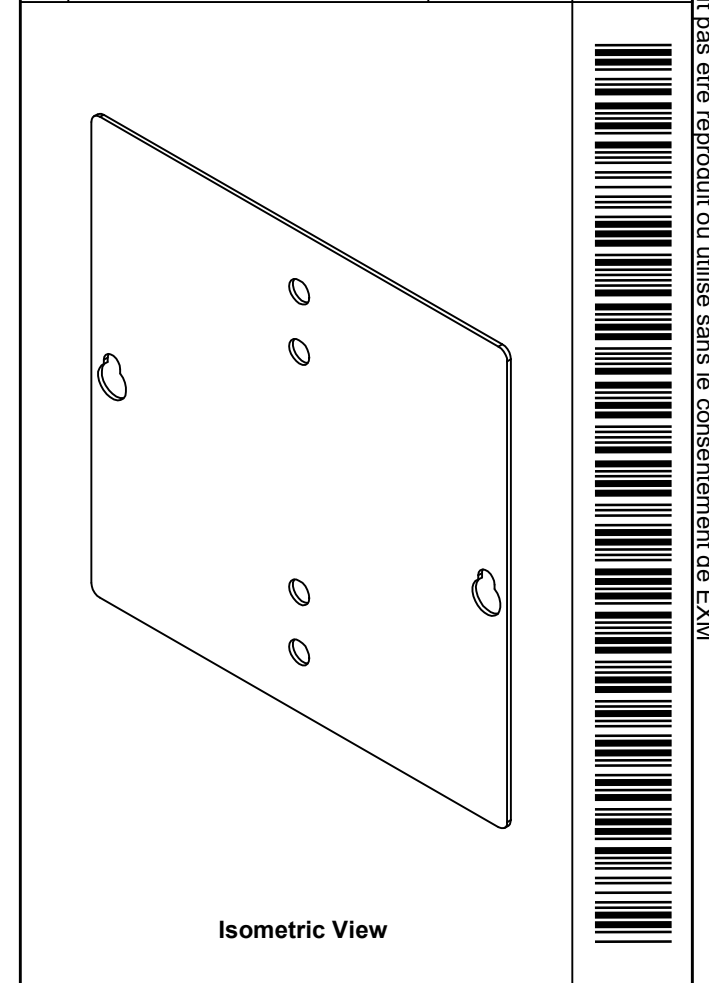

Isometric View

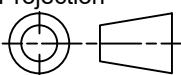
| | | |
|--|---|---|
|  Tél: (450) 979-4373 Fax: (450) 979-4626 www.exmweb.com | | Flatness Aplatissement Max 3.0mm Projection  |
| Customer Client | Date | |
| Drawn By Dessiné Par | BoxCad: BoxCad | Date 18-Jul-22 |
| Material Matière | 16 Ga Cold Rolled A1008 CS Type B (1.4mm) | |
| Color Couleur | Asa-61 Grey | Finish Fini Smooth |
| Description | Detail Rev. | |
| 1100DFPN 6" x 6" Cover | | |
| Part Number Numéro Pièce | Rev. 0 | 8 / 10 |

SEE BILL OF MATERIAL ON LAST PAGE

1100DFP060606NC

This drawing is confidential and must not be reproduced or used without the consent of EXM

Ce dessin est confidentiel et ne doit pas être reproduit ou utilisé sans le consentement de EXM

| STANDARD FEATURES ARE NOT LISTED IN THIS HOLE TABLE | | | |
|---|-------|-------|-------------|
| HOLE TABLE - FRONT VIEW (CUSTOM FEATURE ONLY) | | | |
| CUT-OUT | XDIM | YDIM | DESCRIPTION |
| 1 | 3.000 | 5.250 | RND Ø0.290 |
| 2 | 3.000 | 4.500 | RND Ø0.290 |
| 3 | 3.000 | 1.500 | RND Ø0.290 |
| 4 | 3.000 | 0.750 | RND Ø0.290 |

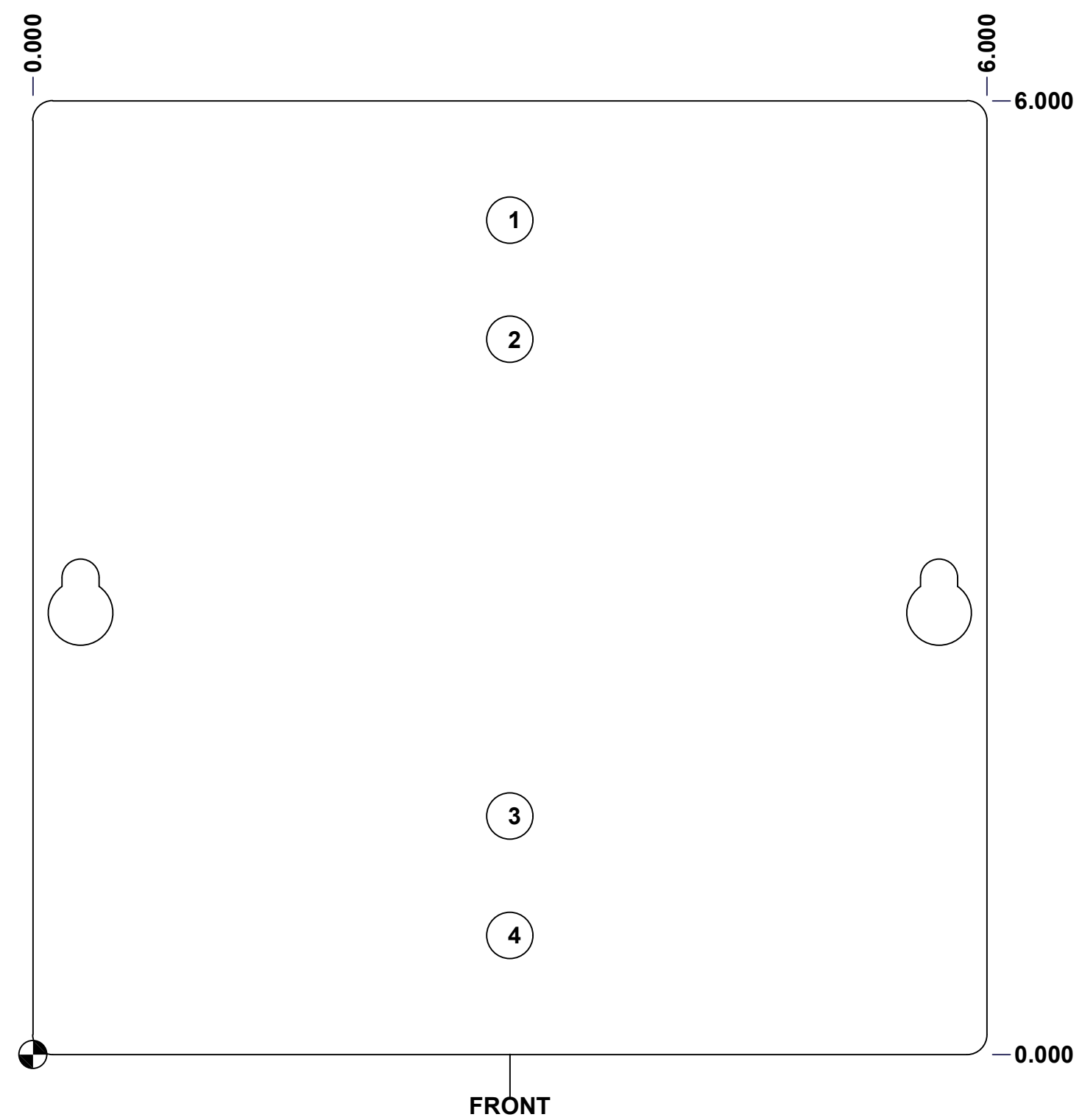

| | | |
|--|---|-------------------------|
| | Description 1100DFPN 6" x 6" Cover | Status (NULL) |
| | Part Number Numéro Pièce 1100DFP060606NC | Rev. 9 0 / 10 |

This drawing is confidential and must not be reproduced or used without the consent of EXM

Ce dessin est confidentiel et ne doit pas être reproduit ou utilisé sans le consentement de EXM

| No. | Revisions | Date | By/Par |
|-----|-----------|------|--------|
| | | | |
| | | | |
| | | | |
| | | | |
| | | | |

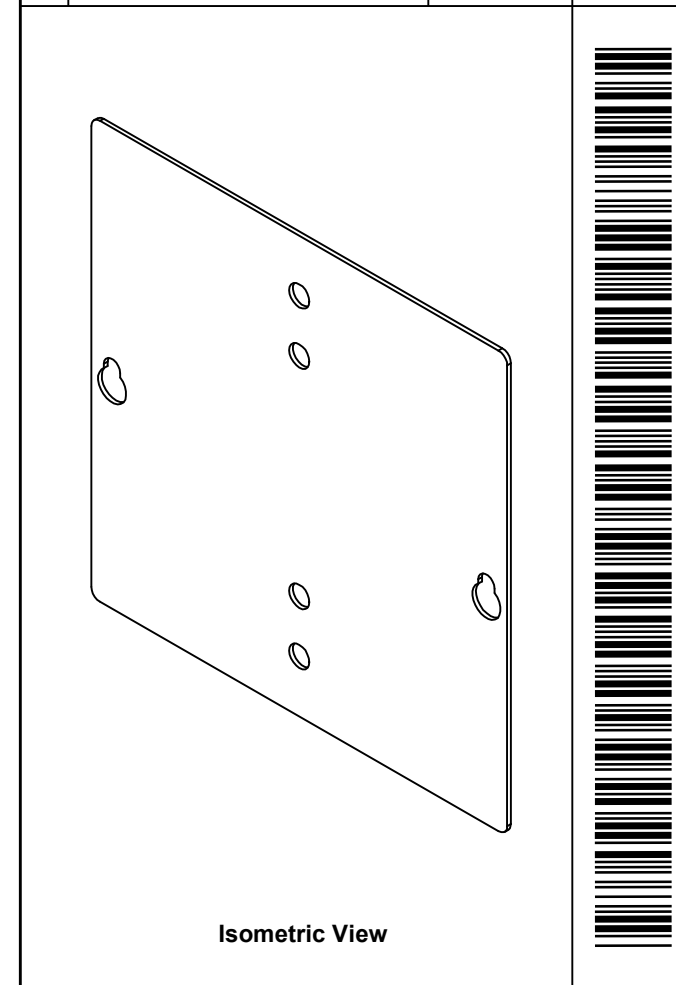

| | |
|--|---|
|  Tél: (450) 979-4373 Fax: (450) 979-4626 www.exmweb.com | Flatness Aplatissement |
| | Max 3.0mm |
| Projection |  |

| | |
|--|---|
| Customer Client | Date |
| Drawn By Dessiné Par BoxCad: BoxCad | Date 18-Jul-22 |
| Material Matière | 16 Ga Cold Rolled A1008 CS Type B (1.4mm) |

| | | | |
|------------------|-------------|----------------|--------|
| Color Couleur | Asa-61 Grey | Finish Fini | Smooth |
|------------------|-------------|----------------|--------|

| | |
|------------------------|-------------|
| Description | Detail Rev. |
| 1100DFPN 6" x 6" Cover | |

| | | |
|-----------------------------|----------|----|
| Part Number Numéro Pièce | Rev. | 10 |
| 1100DFP060606NC | 0 | 10 |

| QTY | Part Number | Rev | Description |
|------------|-------------------|-----|-------------------------------------|
| 1 | STK-S-00950 | 1 | UL 74SL Pull-Box Sticker |
| 1 | STK-S-00800 | 2 | CSA Electrical Box Sticker |
| 1 | STK-P-02400S | 0 | Powder Paint (Asa-61 Grey / Smooth) |
| 1 | 1100DFP060606NC-P | 0 | 1100DFPN 6" x 6" Cover Part |
| Parts List | | | |