

This drawing is confidential and must not be reproduced or used without the consent of EXM

Ce dessin est confidentiel et ne doit pas être reproduit ou utilisé sans le consentement de EXM

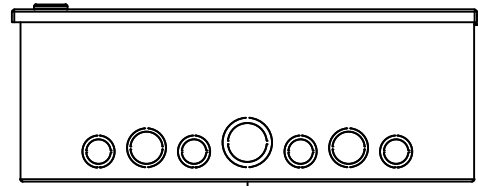

TOP

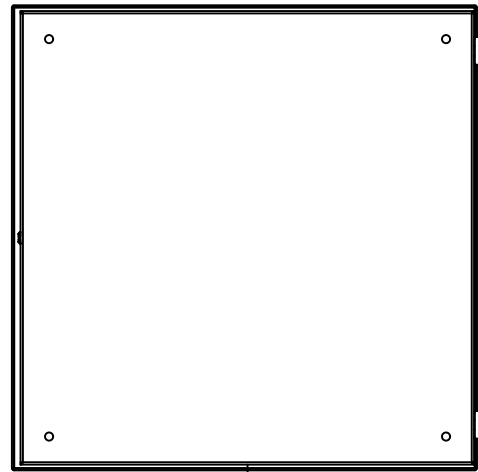

BACK

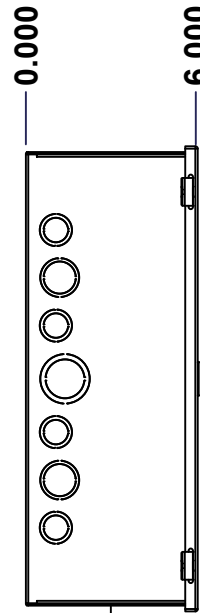

LEFT

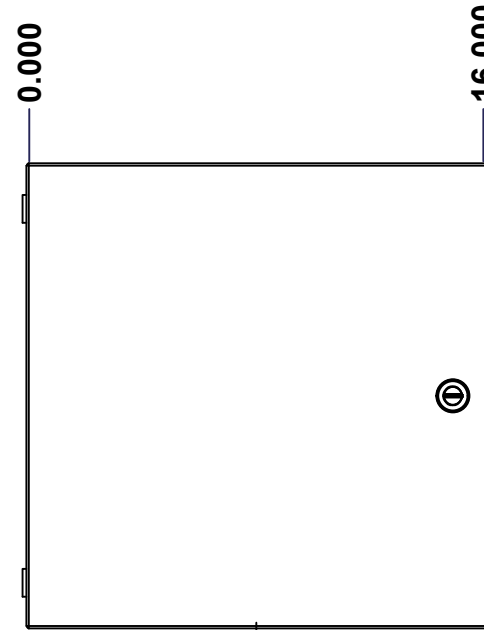

FRONT

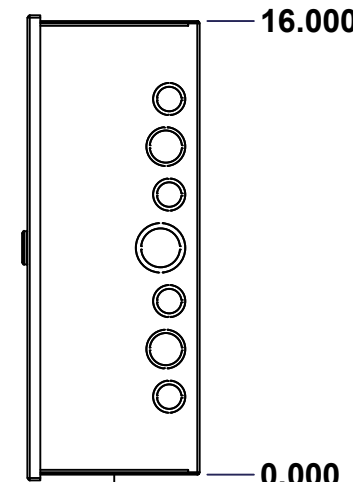

RIGHT

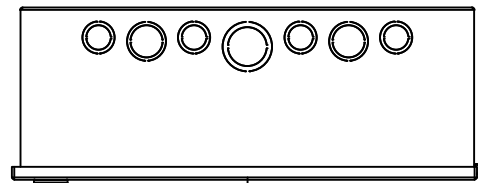

BOTTOM

No.	Revisions	Date	By/Par

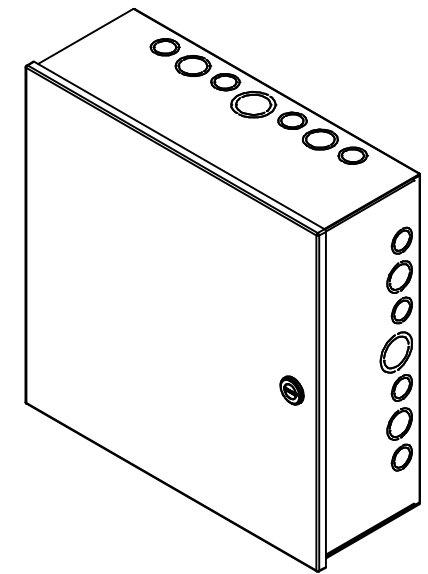

Isometric View



Tél: (450) 979-4373
 Fax: (450) 979-4626
www.exmweb.com

Flatness
Aplatissement

Max 3.0mm

Projection

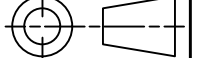

Customer Client	Date
Drawn By / Dessiné Par: BoxCad: BoxCad	Date: 21-Jan-14
Material / Matière: 16 Ga Cold Rolled A1008 CS Type B (1.4mm)	
Color / Couleur: Asa-61 Grey	Finish / Fini: Smooth
Description: 1100E 16" x 16" x 6" Assembly	
Detail Rev.	
Part Number / Numéro Pièce: 1100E161606	Rev. 0

SEE BILL OF MATERIAL ON LAST PAGE

This drawing is confidential and must not be reproduced or used without the consent of EXM

Ce dessin est confidentiel et ne doit pas être reproduit ou utilisé sans le consentement de EXM

NOTE	
ITEM	DESCRIPTION
1	NEMA 1 Enclosure (IP20)
2	C/W Standard ground provision on box and cover
3	W/O Standard door stiffener
4	W/O Inner panel
5	W/O Inner panel mounting provision

No.	Revisions	Date	By/Par

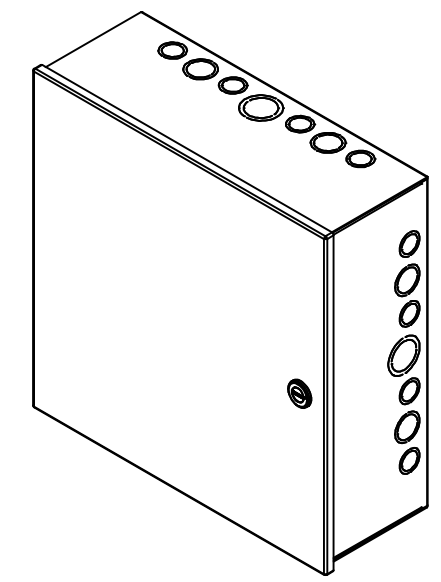

Isometric View



Tél: (450) 979-4373
 Fax: (450) 979-4626
www.exmweb.com

Flatness
Aplatissement
Max 3.0mm
Projection

Customer Client	Date
Drawn By / Dessiné Par: BoxCad: BoxCad	Date: 21-Jan-14
Material / Matière: 16 Ga Cold Rolled A1008 CS Type B (1.4mm)	
Color / Couleur: Asa-61 Grey	Finish / Fini: Smooth

PACKING		
ITEM	QTY	DESCRIPTION
Thermal plastic film	1	Use with Packing Tunnel Wrapper Machine
Packaging label	1	White label with product number

Qty	Part Number	Rev	Description
1	1100E161606C	0	1100E 16" x 16" Cover
1	1100E161606B	0	1100E 16" x 16" x 6" Body
Parts List			

Description: 1100E 16" x 16" x 6" Assembly	Detail Rev.
Part Number / Numéro Pièce: 1100E161606	Rev. 0
	2 / 12

This drawing is confidential and must not be reproduced or used without the consent of EXM

Ce dessin est confidentiel et ne doit pas être reproduit ou utilisé sans le consentement de EXM

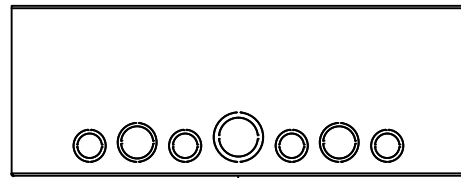

TOP

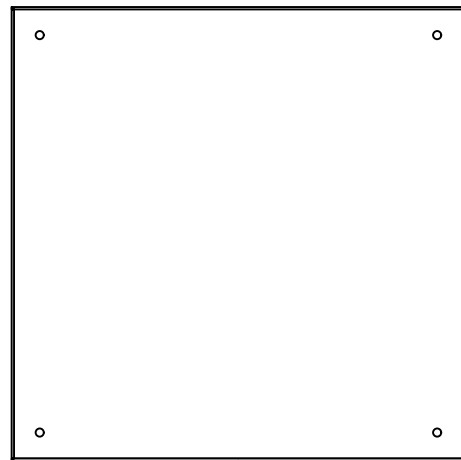

BACK

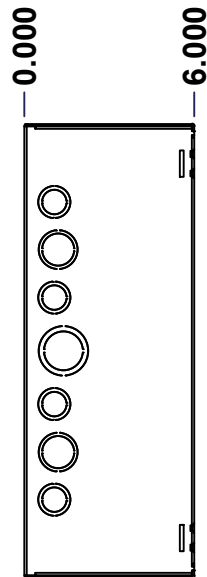

LEFT

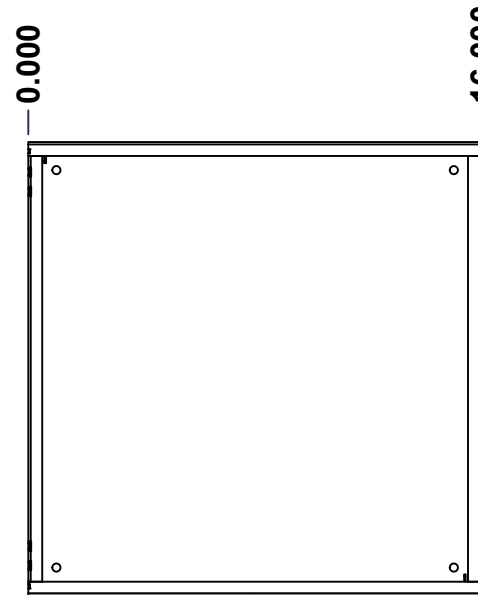

FRONT

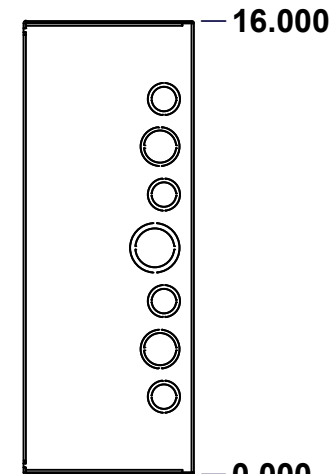

RIGHT

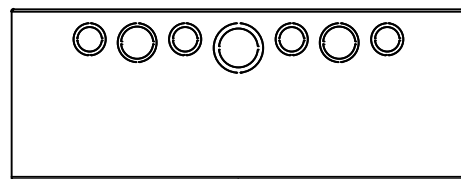

BOTTOM

No.	Revisions	Date	By/Par

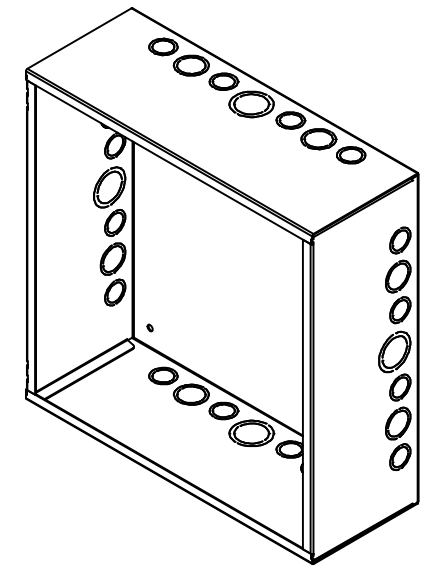

Isometric View



Tél: (450) 979-4373
 Fax: (450) 979-4626
www.exmweb.com

Flatness
Aplatissement

Max 3.0mm

Projection



Customer Client	Date
Drawn By / Dessiné Par: BoxCad: BoxCad	Date: 21-Jan-14
Material / Matière: 16 Ga Cold Rolled A1008 CS Type B (1.4mm)	
Color / Couleur: Asa-61 Grey	Finish / Fini: Smooth
Description: 1100E 16" x 16" x 6" Body	
Detail Rev.	
Part Number / Numéro Pièce: 1100E161606B	Rev. 0
	3 / 12

SEE BILL OF MATERIAL ON LAST PAGE

This drawing is confidential and must not be reproduced or used without the consent of EXM

Ce dessin est confidentiel et ne doit pas être reproduit ou utilisé sans le consentement de EXM

STANDARD FEATURES ARE NOT LISTED IN THIS HOLE TABLE			
HOLE TABLE - TOP VIEW (CUSTOM FEATURE ONLY)			
CUT-OUT	XDIM	YDIM	DESCRIPTION
1	6.125	1.063	DKO Ø1.125 - 0.875
2	13.251	1.063	DKO Ø1.125 - 0.875
3	11.563	1.188	DKO Ø1.375 - 1.125
4	9.875	1.063	DKO Ø1.125 - 0.875
5	8.000	1.375	DKO Ø1.750 - 1.375
6	4.437	1.188	DKO Ø1.375 - 1.125
7	2.749	1.063	DKO Ø1.125 - 0.875

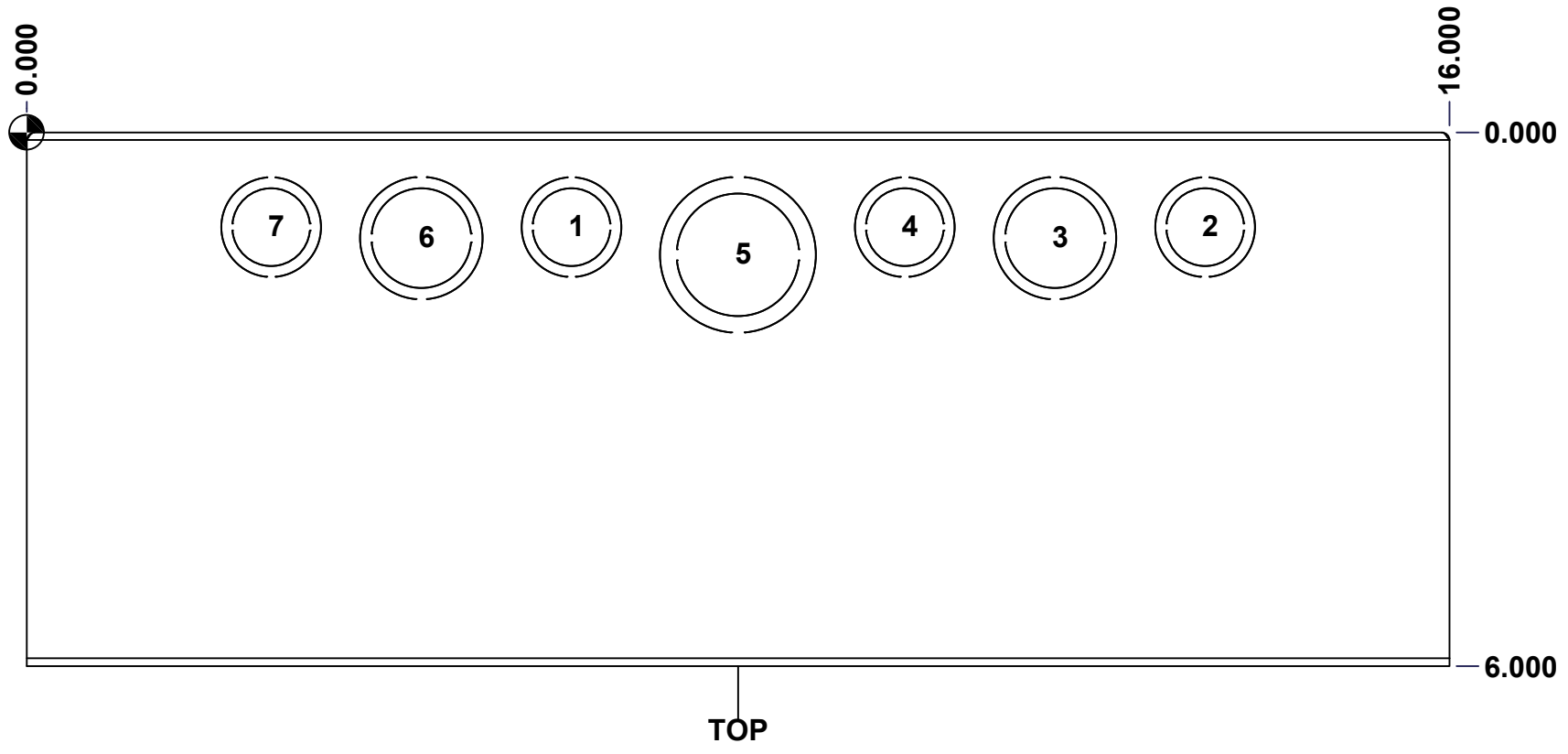

	Description	Status	
	1100E 16" x 16" x 6" Body	(NULL)	
	Part Number Numéro Pièce	Rev.	
	1100E161606B	0	4 12

This drawing is confidential and must not be reproduced or used without the consent of EXM

Ce dessin est confidentiel et ne doit pas être reproduit ou utilisé sans le consentement de EXM

STANDARD FEATURES ARE NOT LISTED IN THIS HOLE TABLE

HOLE TABLE - RIGHT VIEW (CUSTOM FEATURE ONLY)

CUT-OUT	XDIM	YDIM	DESCRIPTION
1	1.063	13.251	DKO Ø1.125 - 0.875
2	1.188	11.563	DKO Ø1.375 - 1.125
3	1.063	9.875	DKO Ø1.125 - 0.875
4	1.375	8.000	DKO Ø1.750 - 1.375
5	1.063	6.125	DKO Ø1.125 - 0.875
6	1.188	4.437	DKO Ø1.375 - 1.125
7	1.063	2.749	DKO Ø1.125 - 0.875

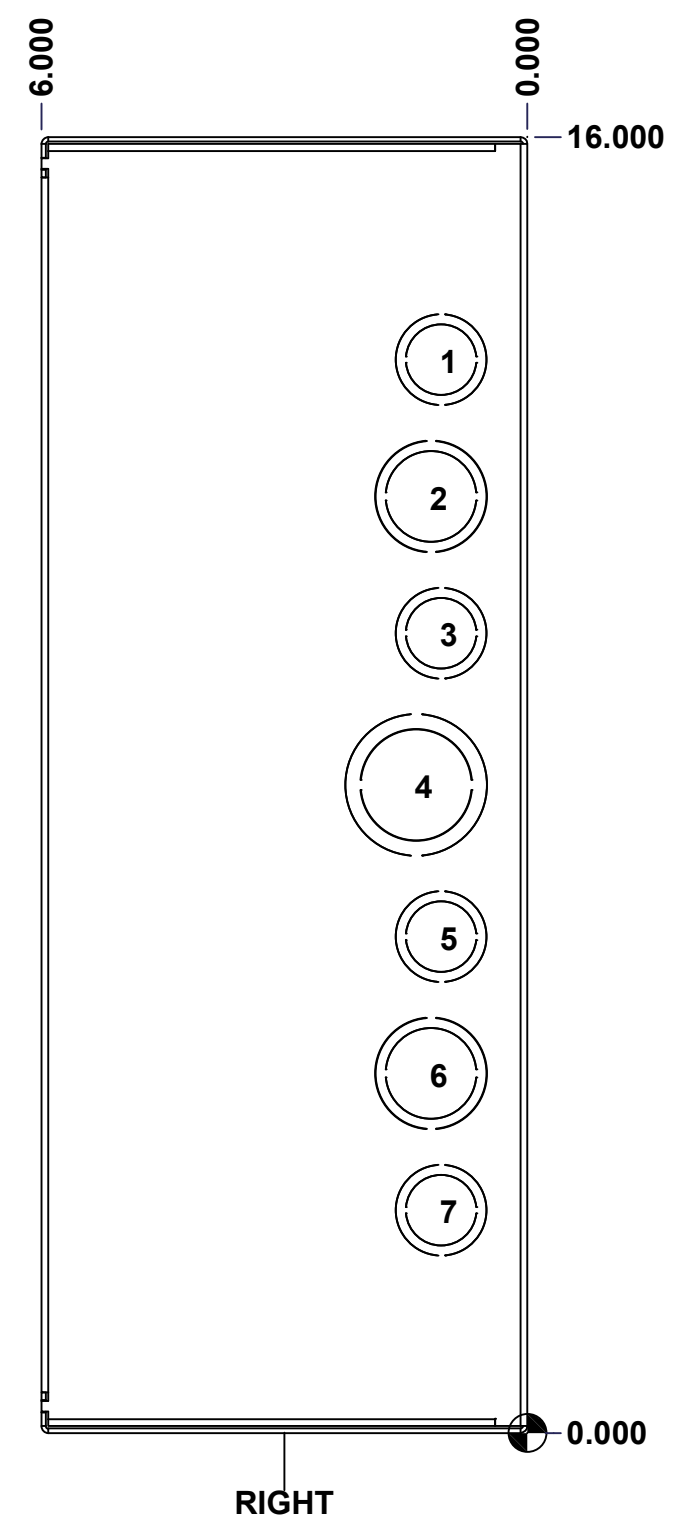

	Description	Status	
	1100E 16" x 16" x 6" Body	(NULL)	
	Part Number Numéro Pièce	Rev.	5
	1100E161606B	0	12

This drawing is confidential and must not be reproduced or used without the consent of EXM

Ce dessin est confidentiel et ne doit pas être reproduit ou utilisé sans le consentement de EXM

STANDARD FEATURES ARE NOT LISTED IN THIS HOLE TABLE

HOLE TABLE - BOTTOM VIEW (CUSTOM FEATURE ONLY)

CUT-OUT	XDIM	YDIM	DESCRIPTION
1	13.251	1.063	DKO Ø1.125 - 0.875
2	11.563	1.188	DKO Ø1.375 - 1.125
3	9.875	1.063	DKO Ø1.125 - 0.875
4	8.000	1.375	DKO Ø1.750 - 1.375
5	6.125	1.063	DKO Ø1.125 - 0.875
6	4.437	1.188	DKO Ø1.375 - 1.125
7	2.749	1.063	DKO Ø1.125 - 0.875

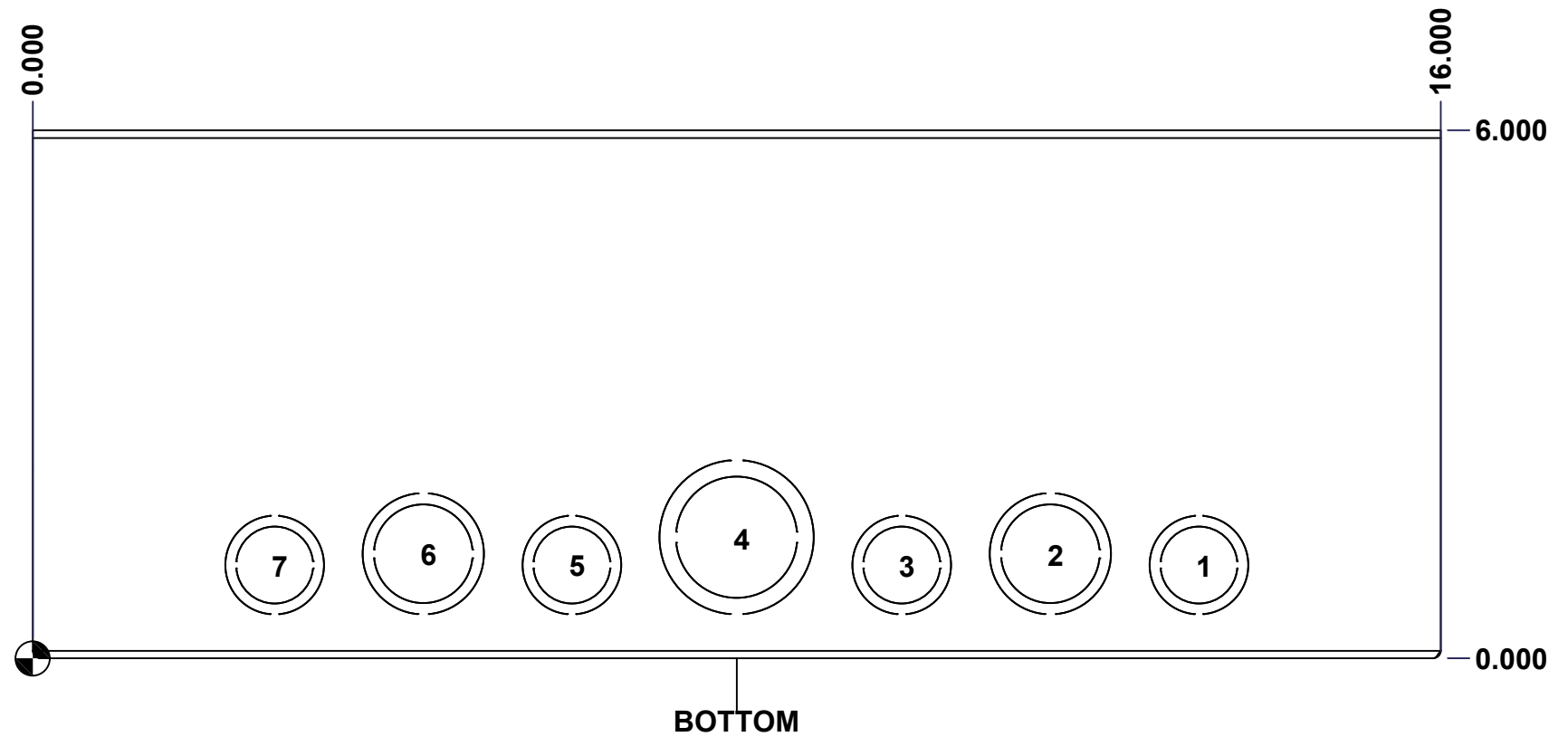

	Description	Status
	1100E 16" x 16" x 6" Body	(NULL)
	Part Number Numéro Pièce	Rev.
	1100E161606B	0 / 6
		12

This drawing is confidential and must not be reproduced or used without the consent of EXM

Ce dessin est confidentiel et ne doit pas être reproduit ou utilisé sans le consentement de EXM

STANDARD FEATURES ARE NOT LISTED IN THIS HOLE TABLE

HOLE TABLE - LEFT VIEW (CUSTOM FEATURE ONLY)

CUT-OUT	XDIM	YDIM	DESCRIPTION
1	1.063	13.251	DKO Ø1.125 - 0.875
2	1.188	11.563	DKO Ø1.375 - 1.125
3	1.063	9.875	DKO Ø1.125 - 0.875
4	1.375	8.000	DKO Ø1.750 - 1.375
5	1.063	6.125	DKO Ø1.125 - 0.875
6	1.188	4.437	DKO Ø1.375 - 1.125
7	1.063	2.749	DKO Ø1.125 - 0.875

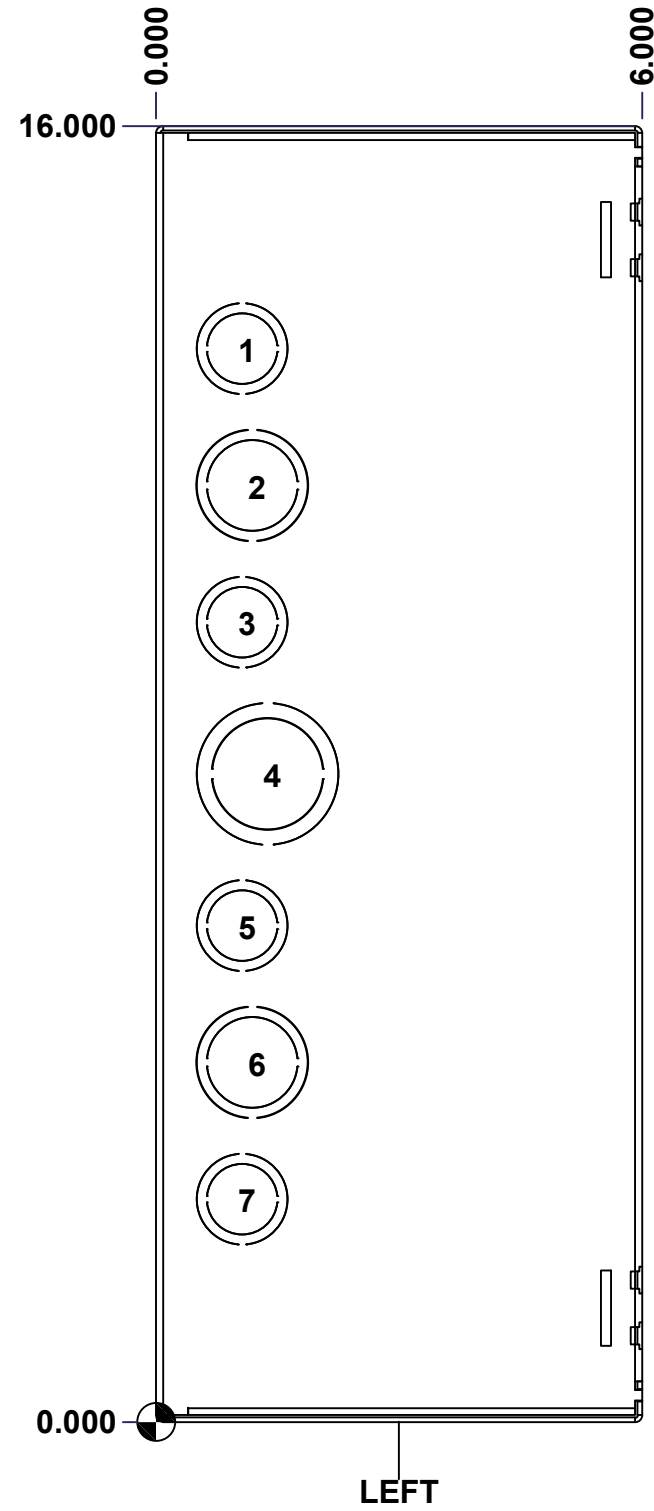

	Description	Status	
	1100E 16" x 16" x 6" Body	(NULL)	
	Part Number Numéro Pièce	Rev.	7
	1100E161606B	0	12

This drawing is confidential and must not be reproduced or used without the consent of EXM

Ce dessin est confidentiel et ne doit pas être reproduit ou utilisé sans le consentement de EXM

STANDARD FEATURES ARE NOT LISTED IN THIS HOLE TABLE			
HOLE TABLE - BACK VIEW (CUSTOM FEATURE ONLY)			
CUT-OUT	XDIM	YDIM	DESCRIPTION
1	15.000	1.000	RND Ø0.290
2	15.000	15.000	RND Ø0.290
3	1.000	15.000	RND Ø0.290
4	1.000	1.000	RND Ø0.290

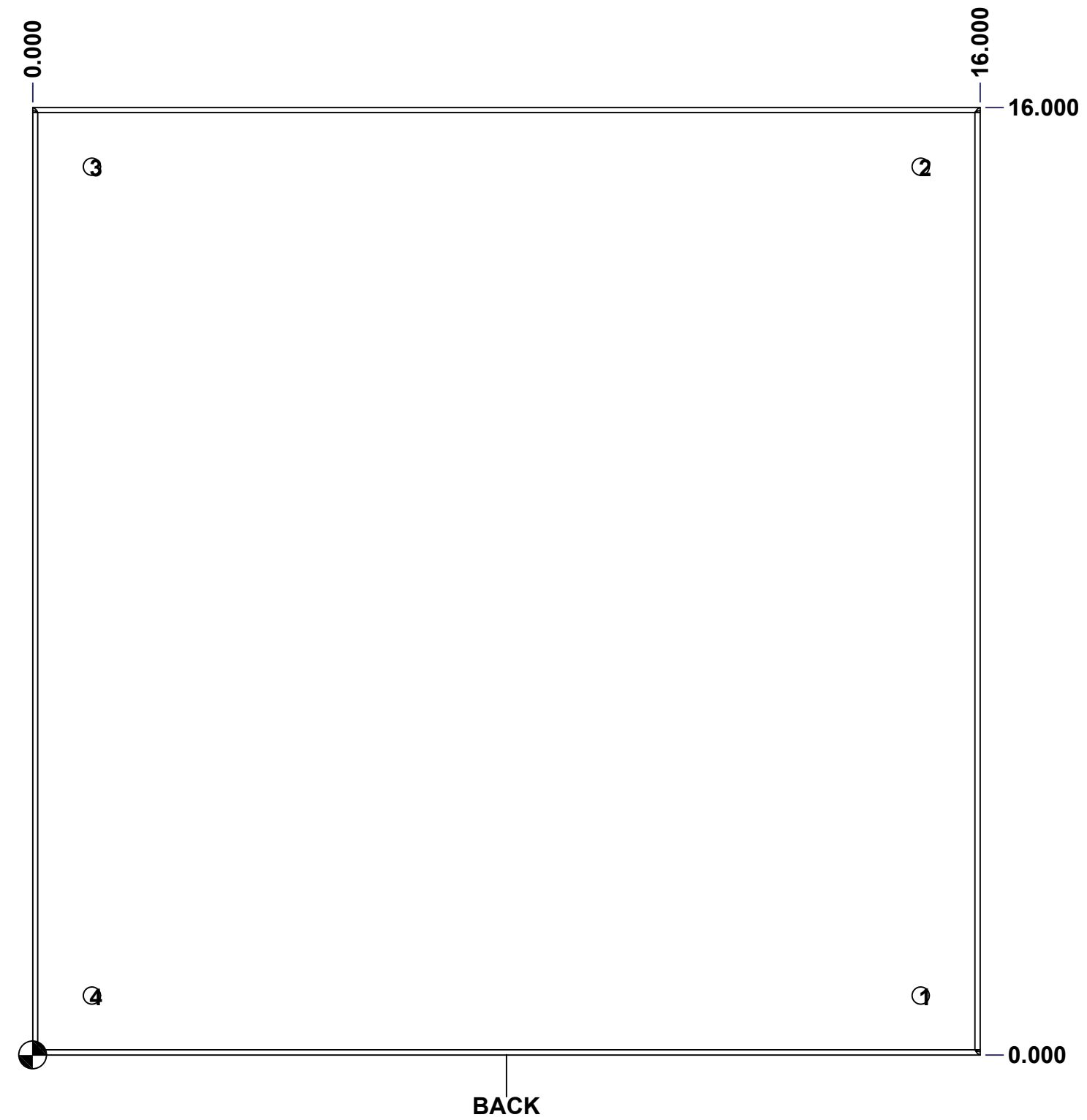

	Description	Status
	1100E 16" x 16" x 6" Body	(NULL)
	Part Number Numéro Pièce	Rev.
	1100E161606B	0 / 8
		12

This drawing is confidential and must not be reproduced or used without the consent of EXM

Ce dessin est confidentiel et ne doit pas être reproduit ou utilisé sans le consentement de EXM

No.	Revisions	Date	By/Par

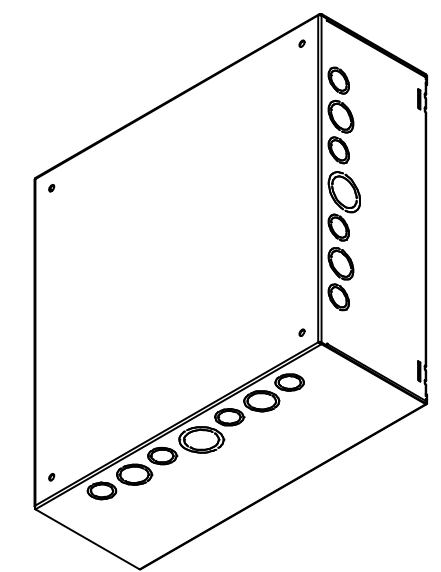

Isometric View

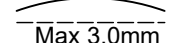
 Tél: (450) 979-4373 Fax: (450) 979-4626 www.exmweb.com		Flatness Aplatissement  Max 3.0mm
Customer Client		Date
Drawn By / Dessiné Par: BoxCad: BoxCad		Date: 21-Jan-14
Material / Matière: 16 Ga Cold Rolled A1008 CS Type B (1.4mm)		
Color / Couleur: Asa-61 Grey	Finish / Fini: Smooth	
Description: 1100E 16" x 16" x 6" Body		Detail Rev.
Part Number / Numéro Pièce: 1100E161606B		Rev. 9 0

Qty	Part Number	Rev	Description
1	STK-P-02400S	0	Powder Paint (Asa-61 Grey / Smooth)
1	1100E161606B-P	0	1100E 16" x 16" x 6" Body Part
Parts List			

This drawing is confidential and must not be reproduced or used without the consent of EXM

Ce dessin est confidentiel et ne doit pas être reproduit ou utilisé sans le consentement de EXM

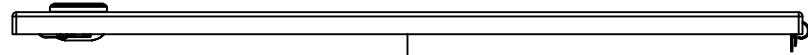

TOP

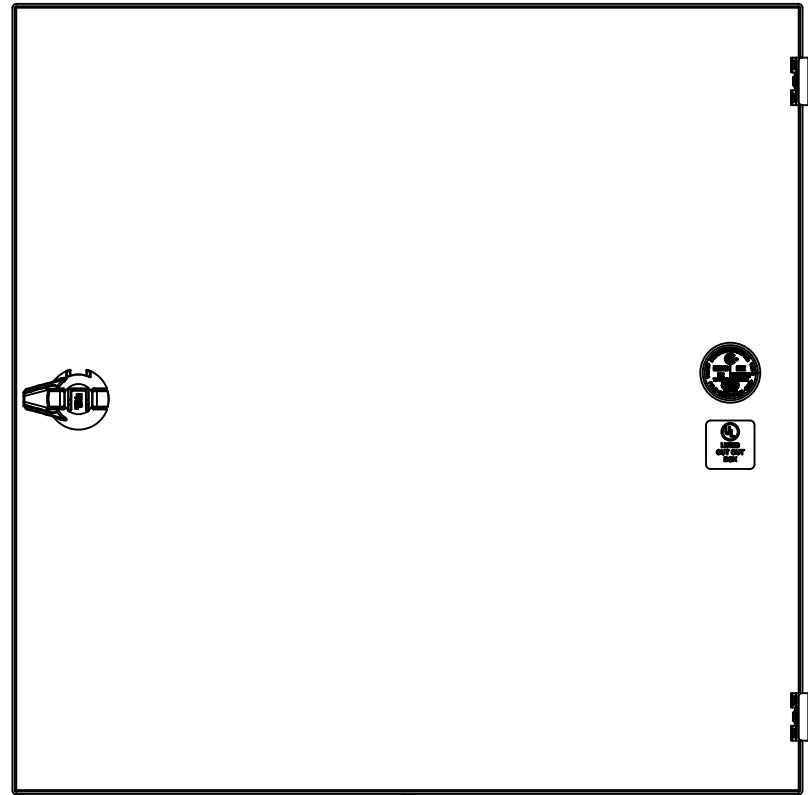

BACK

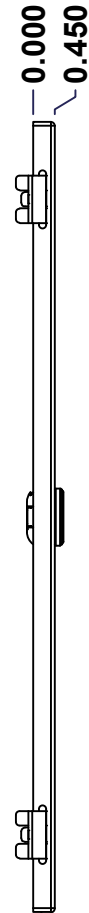

LEFT

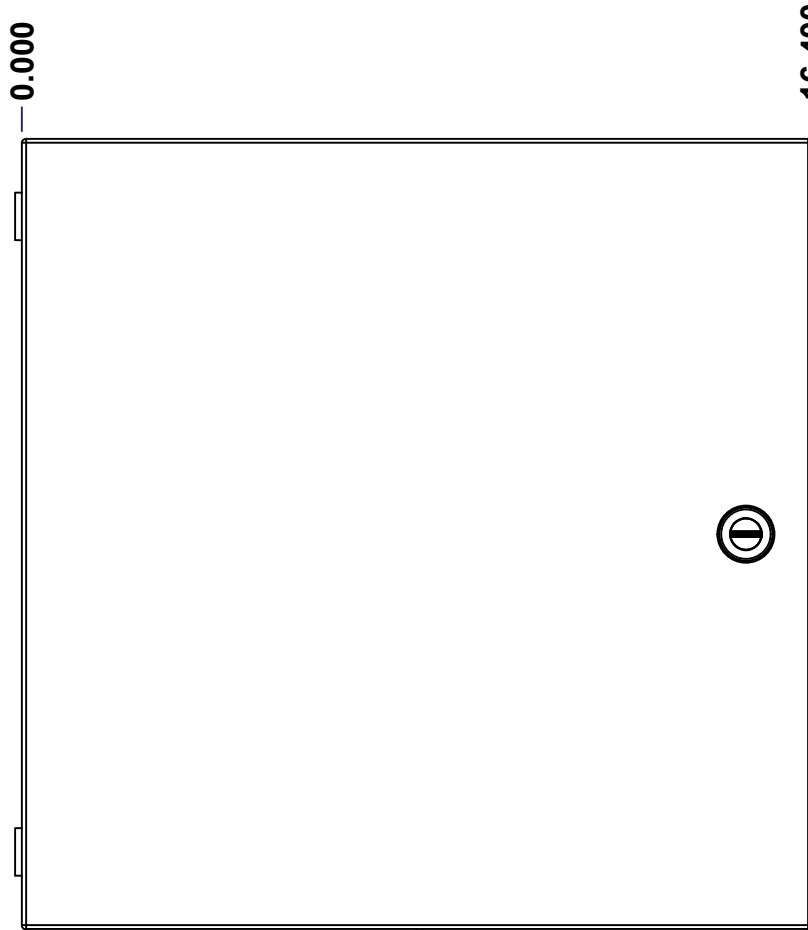

FRONT

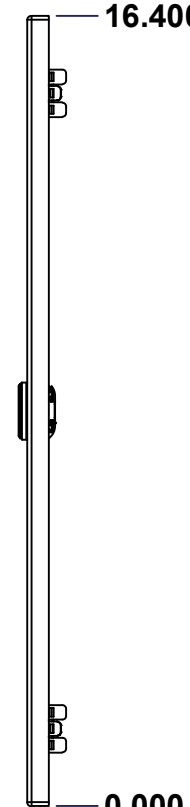

RIGHT

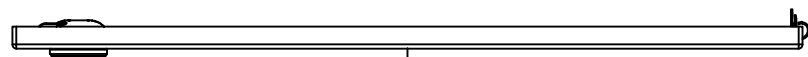

BOTTOM

No.	Revisions	Date	By/Par

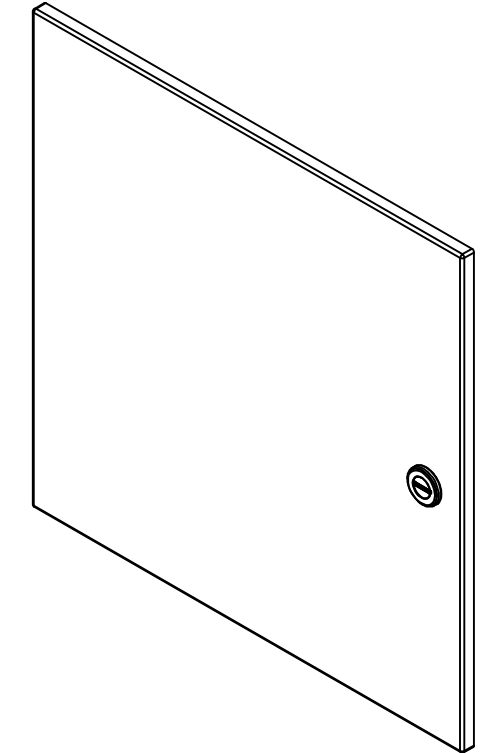

Isometric View



Tél: (450) 979-4373
 Fax: (450) 979-4626
www.exmweb.com

Flatness
Aplatissement

Max 3.0mm

Projection

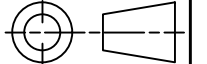

Customer Client	Date
Drawn By / Dessiné Par: BoxCad: BoxCad	Date: 21-Jan-14
Material / Matière: 16 Ga Cold Rolled A1008 CS Type B (1.4mm)	

Color / Couleur: Asa-61 Grey	Finish / Fini: Smooth
------------------------------	-----------------------

Description: 1100E 16" x 16" Cover	Detail Rev.
------------------------------------	-------------

Part Number / Numéro Pièce: 1100E161606C	Rev. 0	10	12
--	--------	----	----

SEE BILL OF MATERIAL ON LAST PAGE

This drawing is confidential and must not be reproduced or used without the consent of EXM

Ce dessin est confidentiel et ne doit pas être reproduit ou utilisé sans le consentement de EXM

STANDARD FEATURES ARE NOT LISTED IN THIS HOLE TABLE			
HOLE TABLE - FRONT VIEW (CUSTOM FEATURE ONLY)			
CUT-OUT	XDIM	YDIM	DESCRIPTION
1	15.025	8.200	LOCK 880 SCQ1-SL @ 0.0°

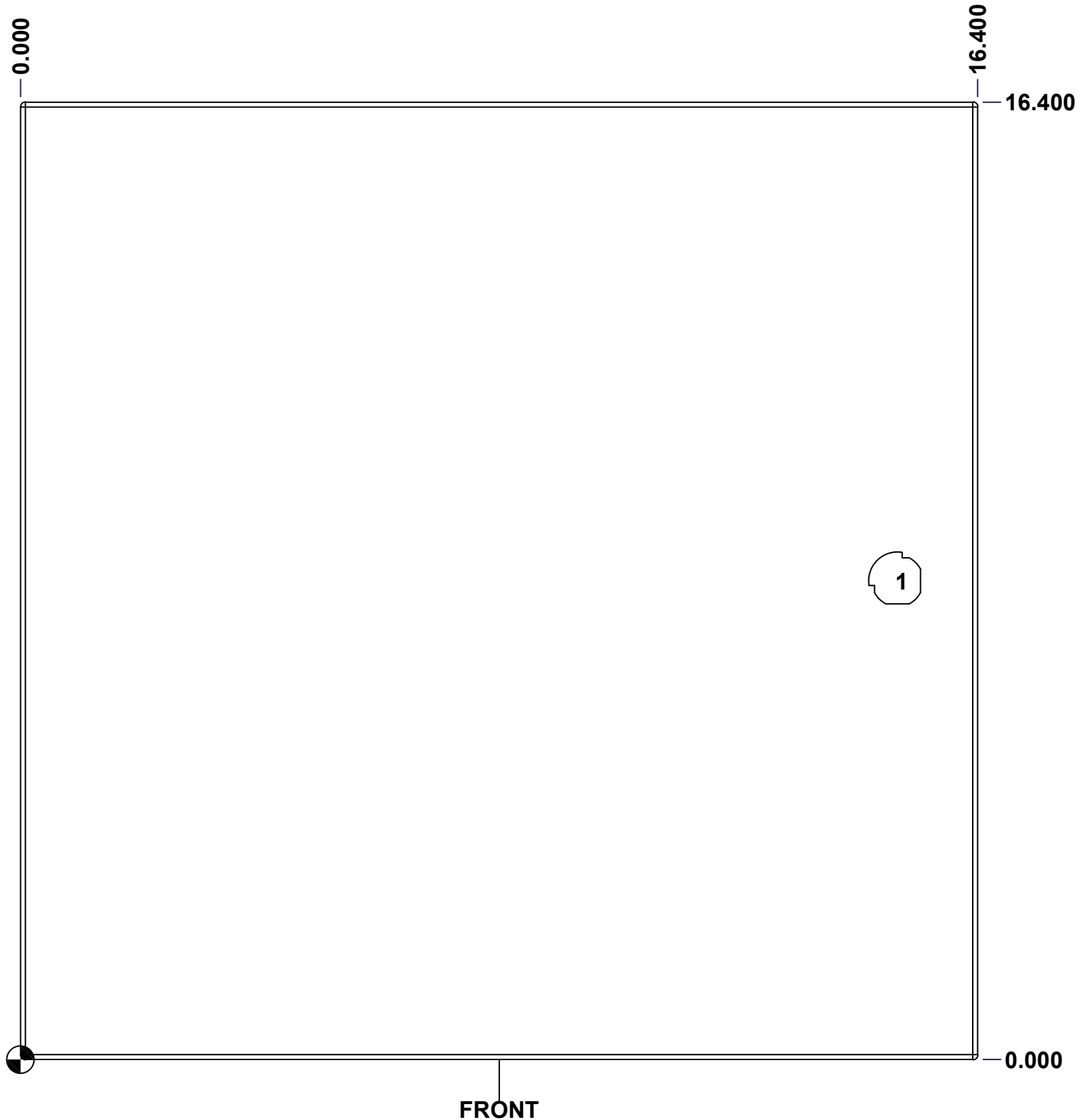

FRONT

	Description	Status	
	1100E 16" x 16" Cover	(NULL)	
	Part Number Numéro Pièce	Rev.	11
	1100E161606C	0	12

This drawing is confidential and must not be reproduced or used without the consent of EXM

Ce dessin est confidentiel et ne doit pas être reproduit ou utilisé sans le consentement de EXM

No.	Revisions	Date	By/Par

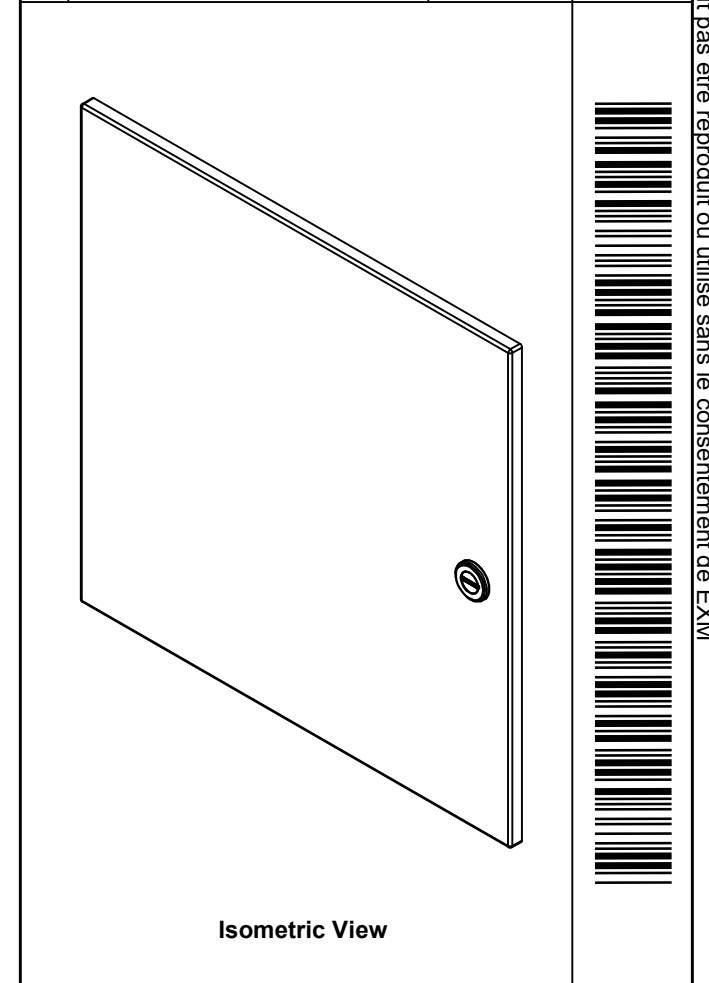

Tél: (450) 979-4373 Fax: (450) 979-4626 www.exmweb.com		Flatness Aplatissement
		Max 3.0mm
Customer Client		Date
Drawn By Dessiné Par BoxCad: BoxCad		Date 21-Jan-14
Material Matière 16 Ga Cold Rolled A1008 CS Type B (1.4mm)		
Color Couleur Asa-61 Grey	Finish Fini Smooth	
Description 1100E 16" x 16" Cover		Detail Rev.
Part Number Numéro Pièce 1100E161606C		Rev. 12 0 12

1	880 SCQ1-SL	0	1100 1/4 Turn Lock
1	STK-S-00900	0	UL Cut-Out Box Sticker
1	STK-S-00800	2	CSA Electrical Box Sticker
2	STK-Q-33361	0	Spring Steel Hinge
1	STK-P-02400S	0	Powder Paint (Asa-61 Grey / Smooth)
1	1100E161606C-P	0	1100E 16" x 16" x 6" Cover Part
QTY	Part Number	Rev	Description
Parts List			