

This drawing is confidential and must not be reproduced or used without the consent of EXM

Ce dessin est confidentiel et ne doit pas être reproduit ou utilisé sans le consentement de EXM

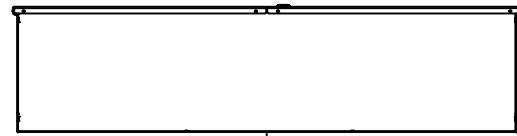

TOP

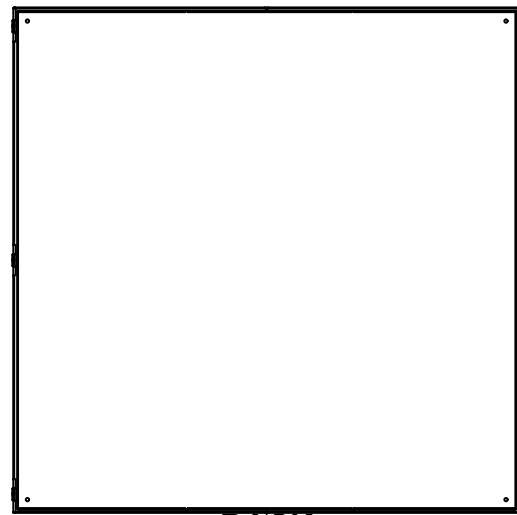

BACK

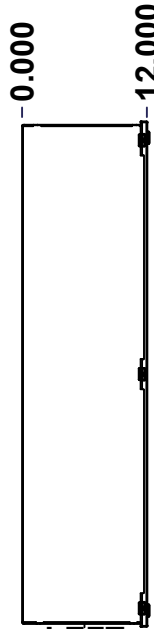

LEFT

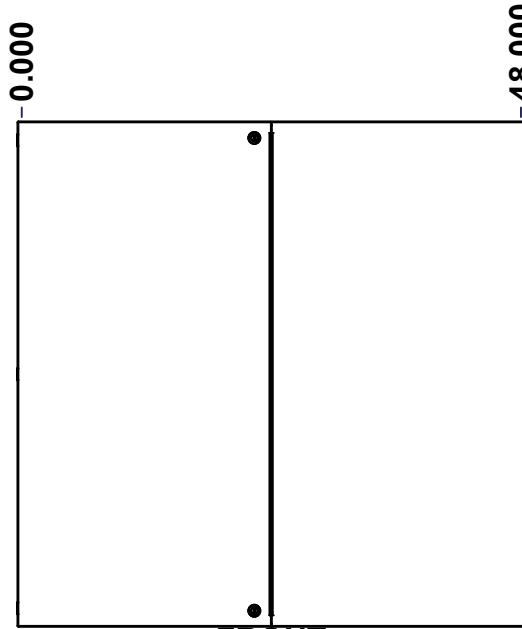

FRONT

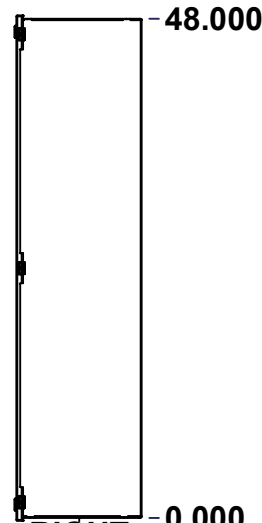

RIGHT

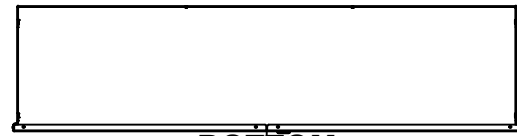

BOTTOM

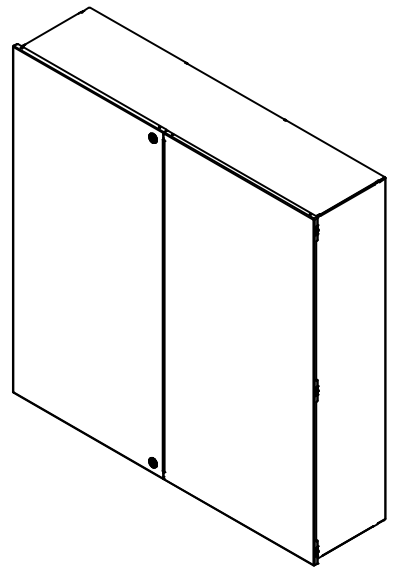

Isometric View

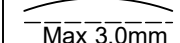
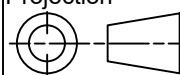

No.	Revisions	Date	By/Par

 Tél: (450) 979-4373 Fax: (450) 979-4626 www.exmweb.com		Flatness Aplatissement  Max 3.0mm Projection 
Customer Client		Date
Drawn By Dessiné Par	BoxCad: BoxCad	Date 28-Jan-14
Material Matière	14 Ga Cold Rolled A1008 CS Type B (1.7mm)	
Color Couleur	Asa-61 Grey	Finish Fini Smooth
Description 1100EN 48" x 48" x 12" Assembly		Detail Rev.
Part Number Numéro Pièce	1100EDD484812N	Rev. 1 0

SEE BILL OF MATERIAL ON LAST PAGE

This drawing is confidential and must not be reproduced or used without the consent of EXM

Ce dessin est confidentiel et ne doit pas être reproduit ou utilisé sans le consentement de EXM

NOTE	
ITEM	DESCRIPTION
1	NEMA 1 Enclosure
2	C/W Standard ground provision on box and cover
3	W/O Standard door stiffener
4	W/O Inner panel
5	W/O Inner panel mounting provision

No.	Revisions	Date	By/Par

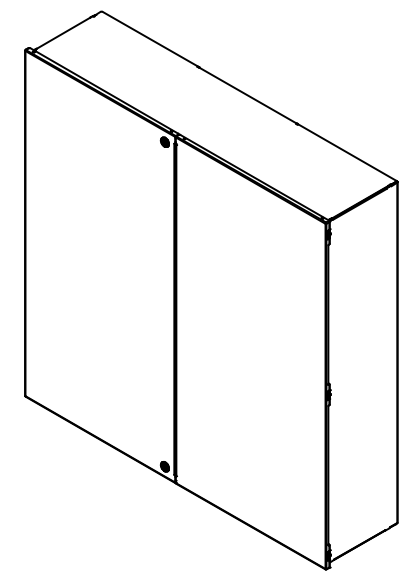

Isometric View



PACKING		
ITEM	QTY	DESCRIPTION
Cardboard sleeve	2	Top and Bottom
Plastic strap - Black	2	To squeeze the 2 cardboard sleeve together
Thermal plastic film	1	Use with Packing Tunnel Wrapper Machine
Packaging label	1	White label with product number

1	1100EDD484812NFD	0	1100EN 48" x 48" Flange Cover
1	1100EDD484812NLD	0	1100EN 48" x 48" Lock Cover
1	1100EDD484812NB	0	1100EN 48" x 48" x 12" Body
Qty	Part Number	Rev	Description
Parts List			

	Tél: (450) 979-4373 Fax: (450) 979-4626 www.exmweb.com	Flatness Aplatissement Max 3.0mm Projection
	Customer Client	Date
Drawn By Dessiné Par	BoxCad: BoxCad	Date 28-Jan-14
Material Matière	14 Ga Cold Rolled A1008 CS Type B (1.7mm)	
Color Couleur	Asa-61 Grey	Finish Fini Smooth
Description 1100EN 48" x 48" x 12" Assembly	Detail Rev.	
Part Number Numéro Pièce 1100EDD484812N	Rev. 0	2 / 10

This drawing is confidential and must not be reproduced or used without the consent of EXM

Ce dessin est confidentiel et ne doit pas être reproduit ou utilisé sans le consentement de EXM



TOP

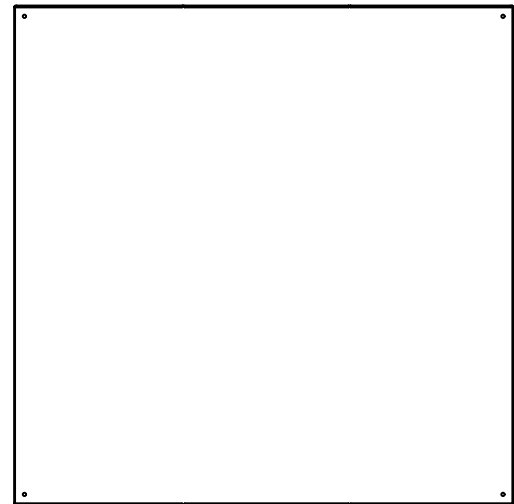

BACK

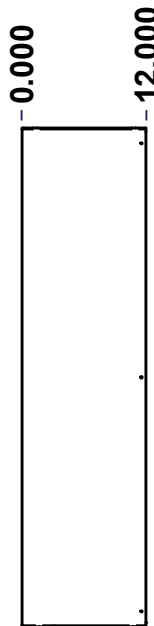

LEFT

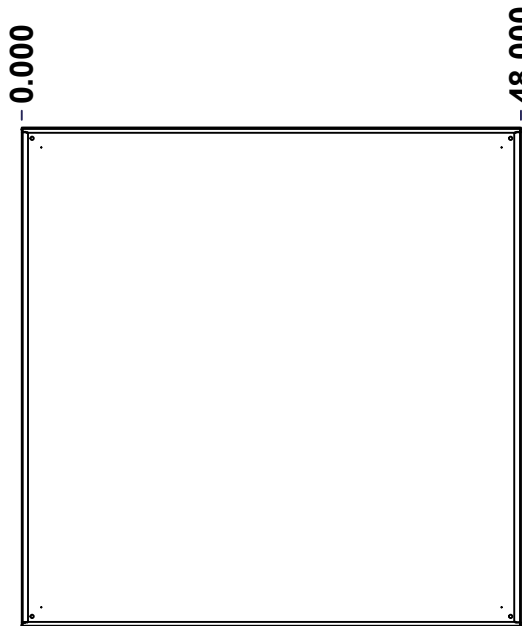

FRONT

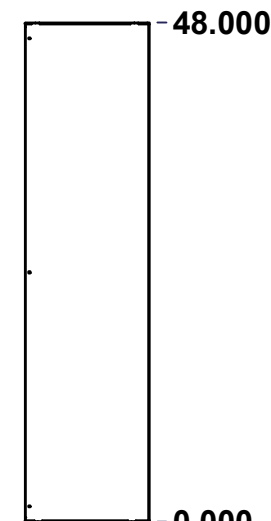

RIGHT



BOTTOM

No.	Revisions	Date	By/Par

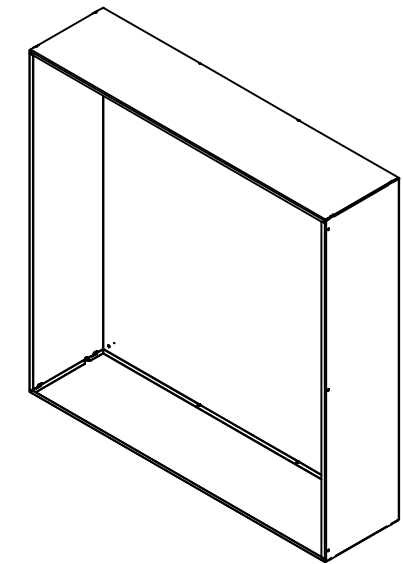

Isometric View



Tél: (450) 979-4373
 Fax: (450) 979-4626
www.exmweb.com

Flatness
Aplatissement

Max 3.0mm

Projection

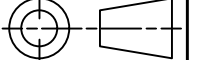

Customer Client	Date
Drawn By Dessiné Par BoxCad: BoxCad	Date 28-Jan-14
Material Matière 14 Ga Cold Rolled A1008 CS Type B (1.7mm)	
Color Couleur Asa-61 Grey	Finish Fini Smooth
Description 1100EN 48" x 48" x 12" Body	Detail Rev.
Part Number Numéro Pièce 1100EDD484812NB	Rev. 0

3
10

SEE BILL OF MATERIAL ON LAST PAGE

This drawing is confidential and must not be reproduced or used without the consent of EXM

Ce dessin est confidentiel et ne doit pas être reproduit ou utilisé sans le consentement de EXM

STANDARD FEATURES ARE NOT LISTED IN THIS HOLE TABLE			
HOLE TABLE - BACK VIEW (CUSTOM FEATURE ONLY)			
CUT-OUT	XDIM	YDIM	DESCRIPTION
1	47.000	1.000	RND Ø0.290
2	47.000	47.000	RND Ø0.290
3	1.000	47.000	RND Ø0.290
4	1.000	1.000	RND Ø0.290

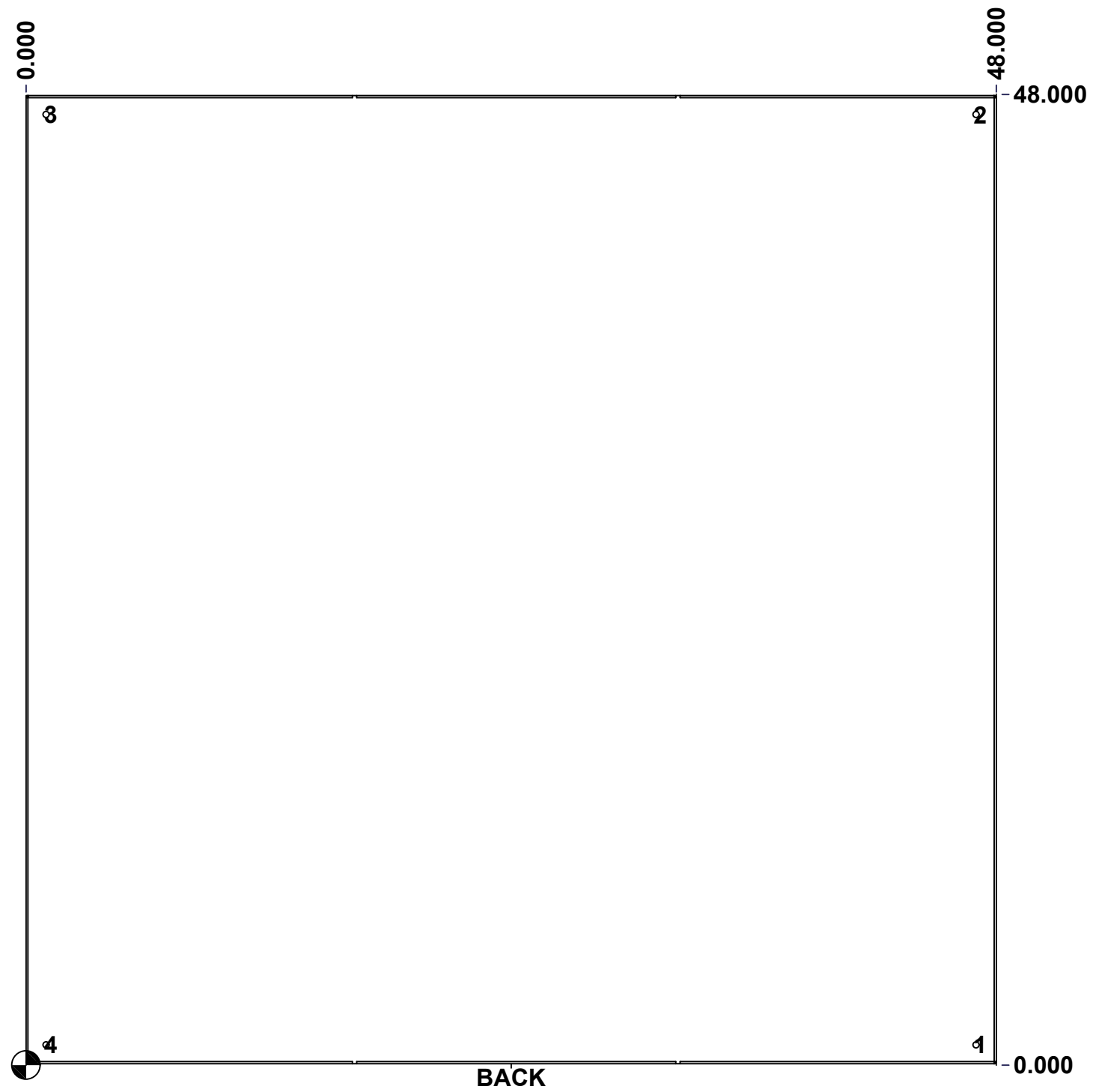

	Description	Status	
	1100EN 48" x 48" x 12" Body	(NULL)	
	Part Number Numéro Pièce	Rev.	
	1100EDD484812NB	0	4 / 10

This drawing is confidential and must not be reproduced or used without the consent of EXM

Ce dessin est confidentiel et ne doit pas être reproduit ou utilisé sans le consentement de EXM

No.	Revisions	Date	By/Par

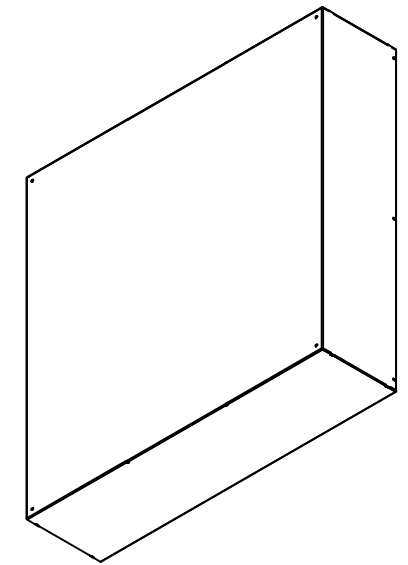

Isometric View

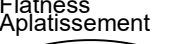
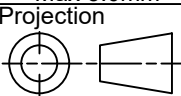

 Tél: (450) 979-4373 Fax: (450) 979-4626 www.exmweb.com		Flatness Aplatissement  Max 3.0mm
Customer Client		Projection 
Drawn By Dessiné Par BoxCad: BoxCad		Date 28-Jan-14
Material Matière 14 Ga Cold Rolled A1008 CS Type B (1.7mm)		
Color Couleur Asa-61 Grey	Finish Fini Smooth	
Description 1100EN 48" x 48" x 12" Body		Detail Rev.
Part Number Numéro Pièce 1100EDD484812NB		Rev. 5 0 / 10

Qty	Part Number	Rev	Description
1	STK-P-02400S	0	Powder Paint (Asa-61 Grey / Smooth)
1	1100EDD484812NT-P	0	1100EN 48" x 48" x 12" Body Part
1	1100EDD484812NBT-P	0	1100EN 48" x 48" x 12" Body Part
1	1100EDD484812NB-P	0	1100EN 48" x 48" x 12" Body Part
Parts List			

This drawing is confidential and must not be reproduced or used without the consent of EXM

Ce dessin est confidentiel et ne doit pas être reproduit ou utilisé sans le consentement de EXM

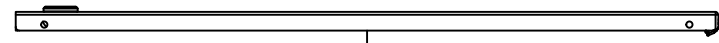

TOP

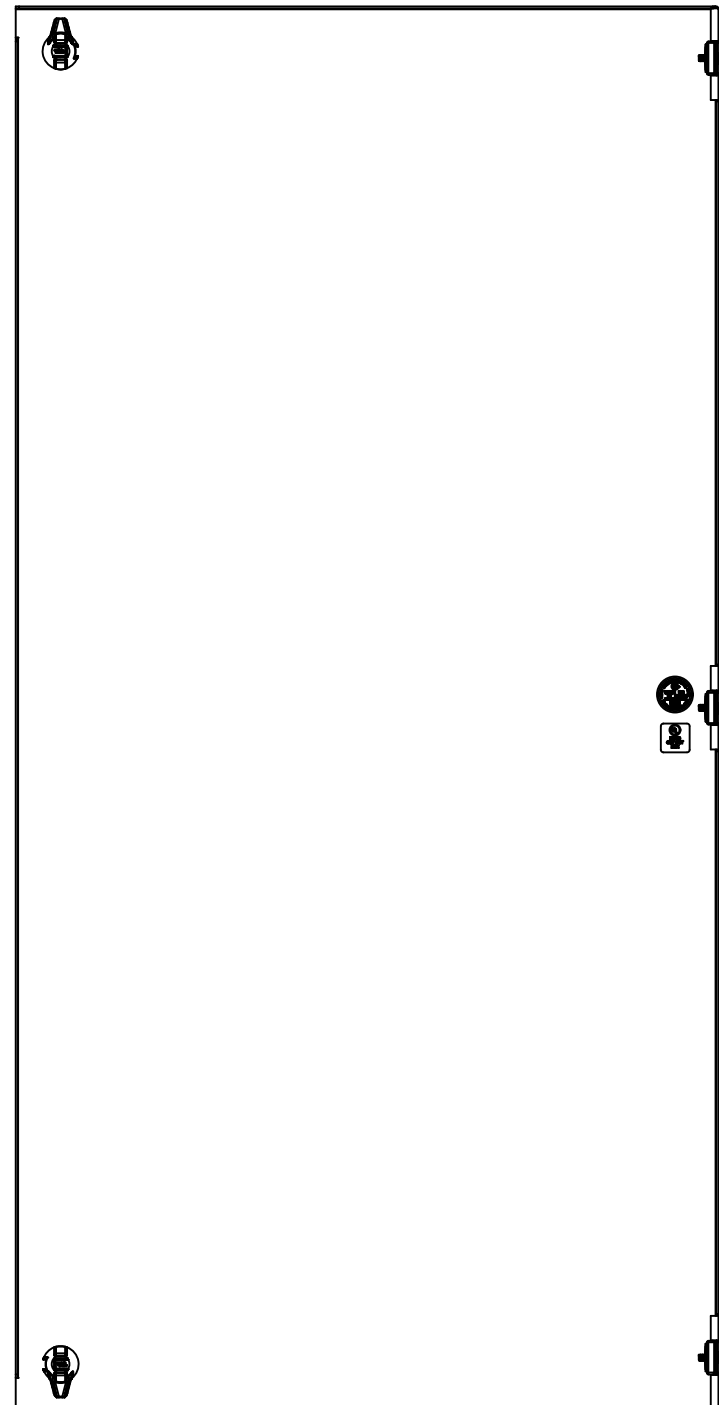

BACK

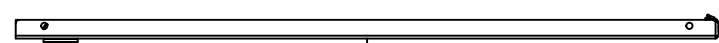

BOTTOM

0.000
0.650

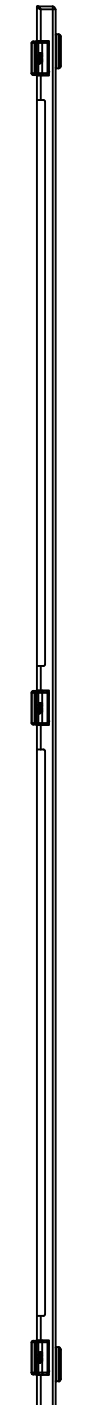

LEFT

0.000

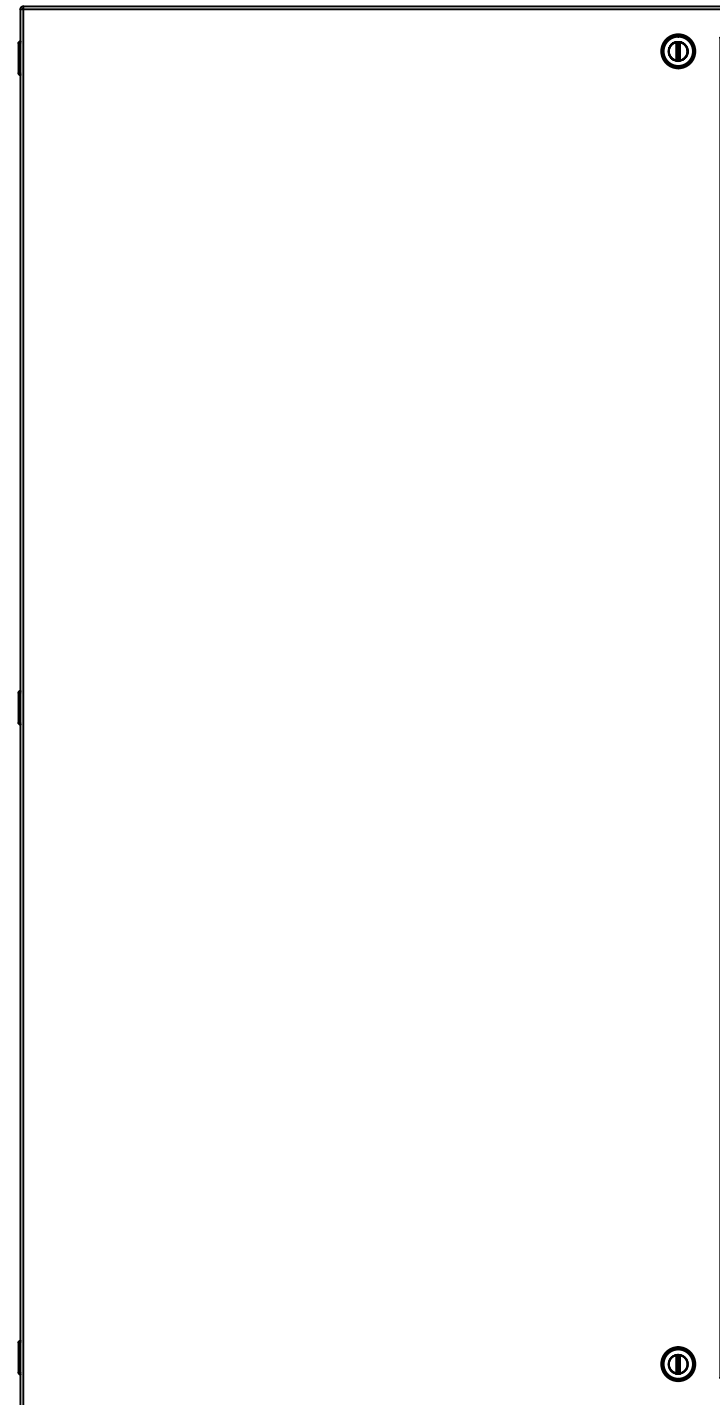

FRONT

24.341

48.592



RIGHT

0.000

No.	Revisions	Date	By/Par

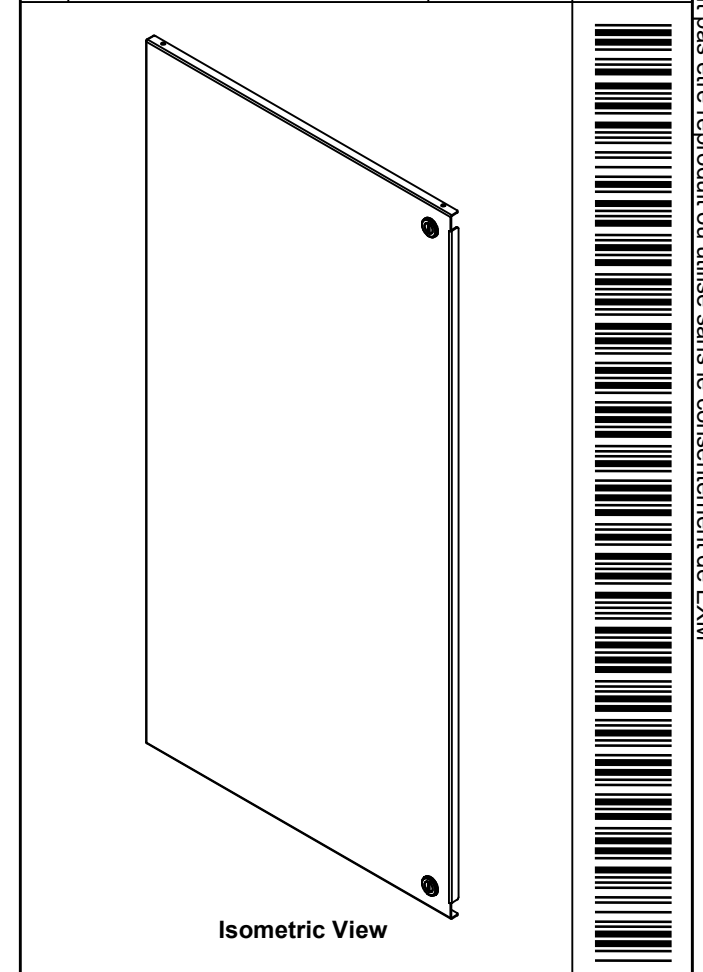

<p>Tél: (450) 979-4373 Fax: (450) 979-4626 www.exmweb.com</p>	Flatness Aplatissement	Max 3.0mm
	Projection	
Customer Client	Date	
Drawn By Dessiné Par	BoxCad: BoxCad	Date 28-Jan-14
Material Matière	14 Ga Cold Rolled A1008 CS Type B (1.7mm)	
Color Couleur	Asa-61 Grey	Finish Fini Smooth
Description	Detail Rev.	
1100EN 48" x 48" Lock Cover		
Part Number Numéro Pièce	Rev.	6
1100EDD484812NLD	0	10

SEE BILL OF MATERIAL ON LAST PAGE

This drawing is confidential and must not be reproduced or used without the consent of EXM

Ce dessin est confidentiel et ne doit pas être reproduit ou utilisé sans le consentement de EXM

STANDARD FEATURES ARE NOT LISTED IN THIS HOLE TABLE			
HOLE TABLE - FRONT VIEW (CUSTOM FEATURE ONLY)			
CUT-OUT	XDIM	YDIM	DESCRIPTION
1	22.779	47.030	LOCK 880 SCQ1-SL @ 90.0°
2	22.779	1.562	LOCK 880 SCQ1-SL @ 270.0°

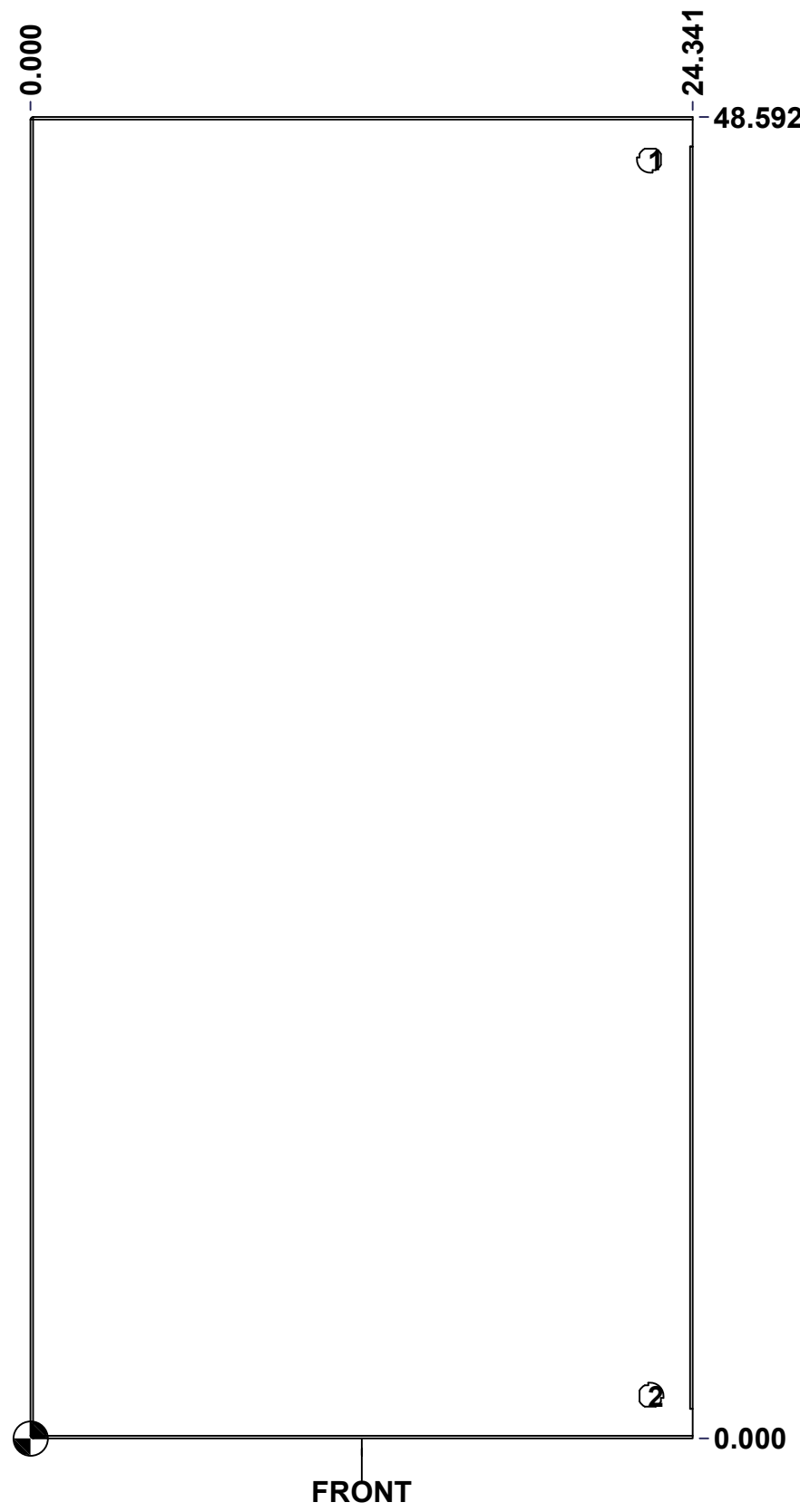



	Description	Status	
	1100EN 48" x 48" x 12" Lock Cover	(NULL)	
	Part Number Numéro Pièce	Rev.	
	1100EDD484812NLC	0	7 / 10

This drawing is confidential and must not be reproduced or used without the consent of EXM

Ce dessin est confidentiel et ne doit pas être reproduit ou utilisé sans le consentement de EXM

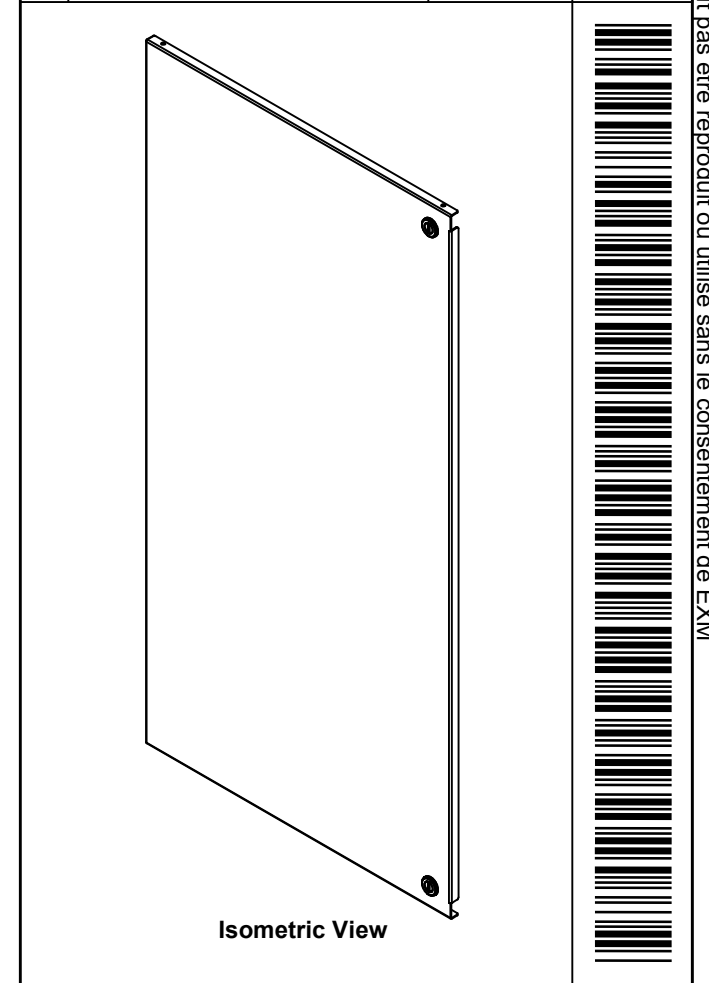
No.	Revisions	Date	By/Par

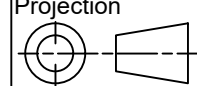

 Tél: (450) 979-4373 Fax: (450) 979-4626 www.exmweb.com	Flatness Aplatissement
	Max 3.0mm
Projection	
Customer Client	Date
Drawn By Dessiné Par	Date 28-Jan-14
Material Matière	14 Ga Cold Rolled A1008 CS Type B (1.7mm)

Qty	Part Number	Rev	Description
1	STK-S-00800	2	CSA Electrical Box Sticker
1	STK-S-00900	0	UL Cut-Out Box Sticker
1	1100EDD484812NLC-P	0	1100EN 48" x 48" x 12" Lock Cover Part
1	STK-P-02400S	0	Powder Paint (Asa-61 Grey / Smooth)
3	STK-A-33033	4	5412 ESMCH Hinge
2	880 SCQ1-SL	0	1100 1/4 Turn Lock
Parts List			

Color Couleur	Asa-61 Grey	Finish Fini	Smooth
Description	1100EN 48" x 48" Lock Cover		
Part Number Numéro Pièce	1100EDD484812NLD		Rev. 8
			0
			10

This drawing is confidential and must not be reproduced or used without the consent of EXM

Ce dessin est confidentiel et ne doit pas être reproduit ou utilisé sans le consentement de EXM

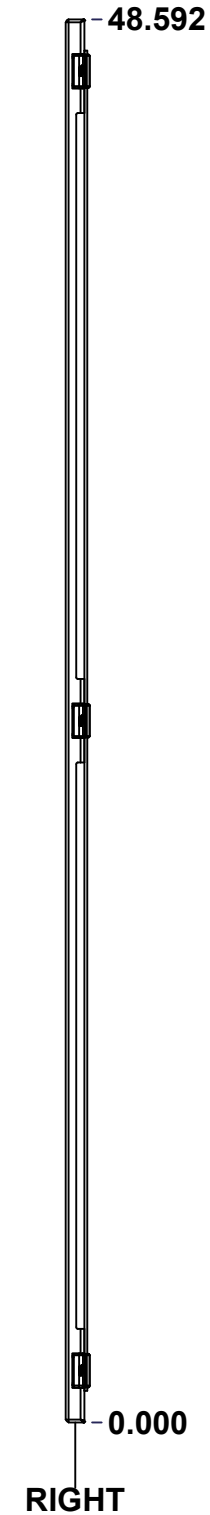
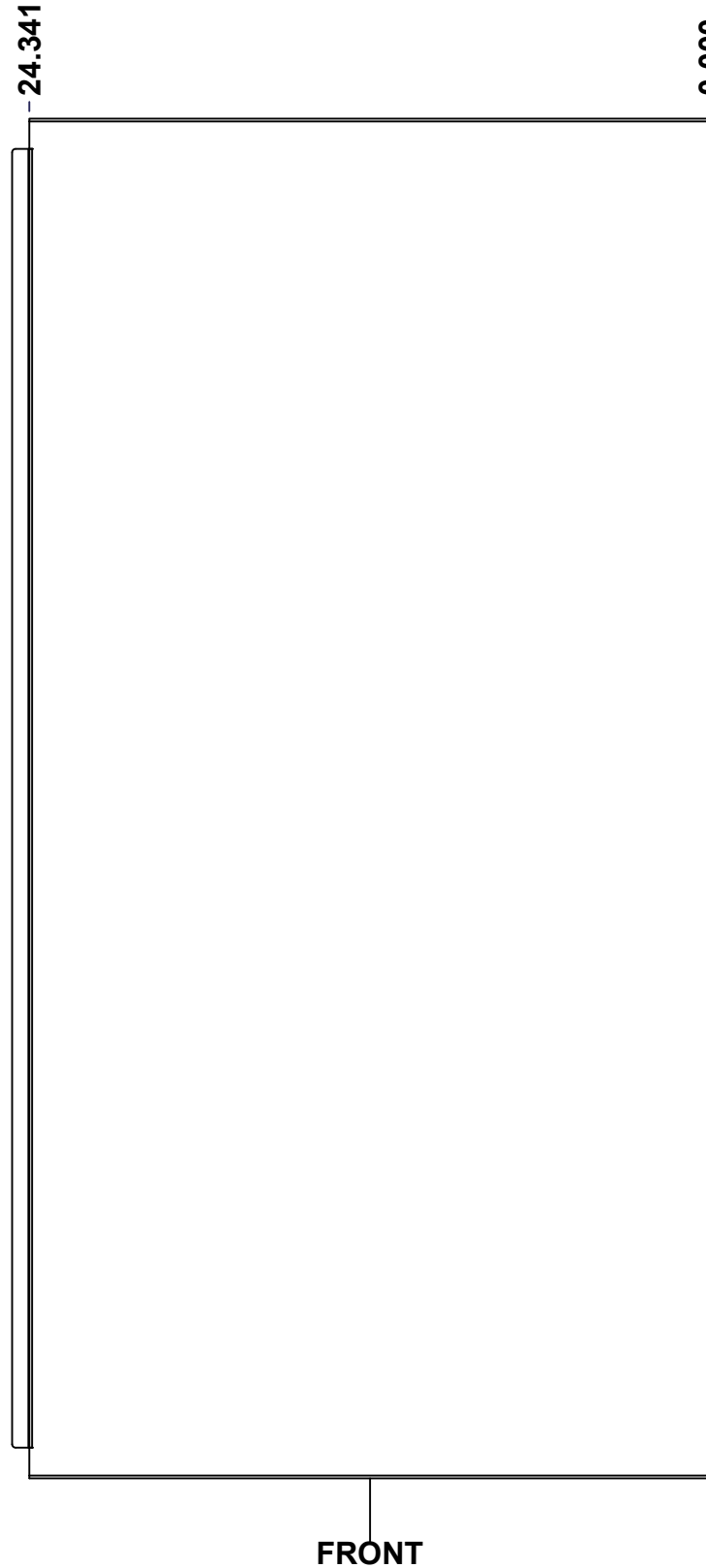
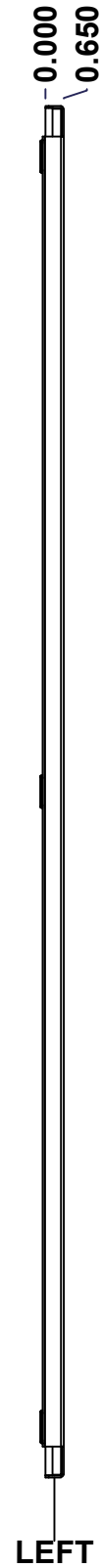
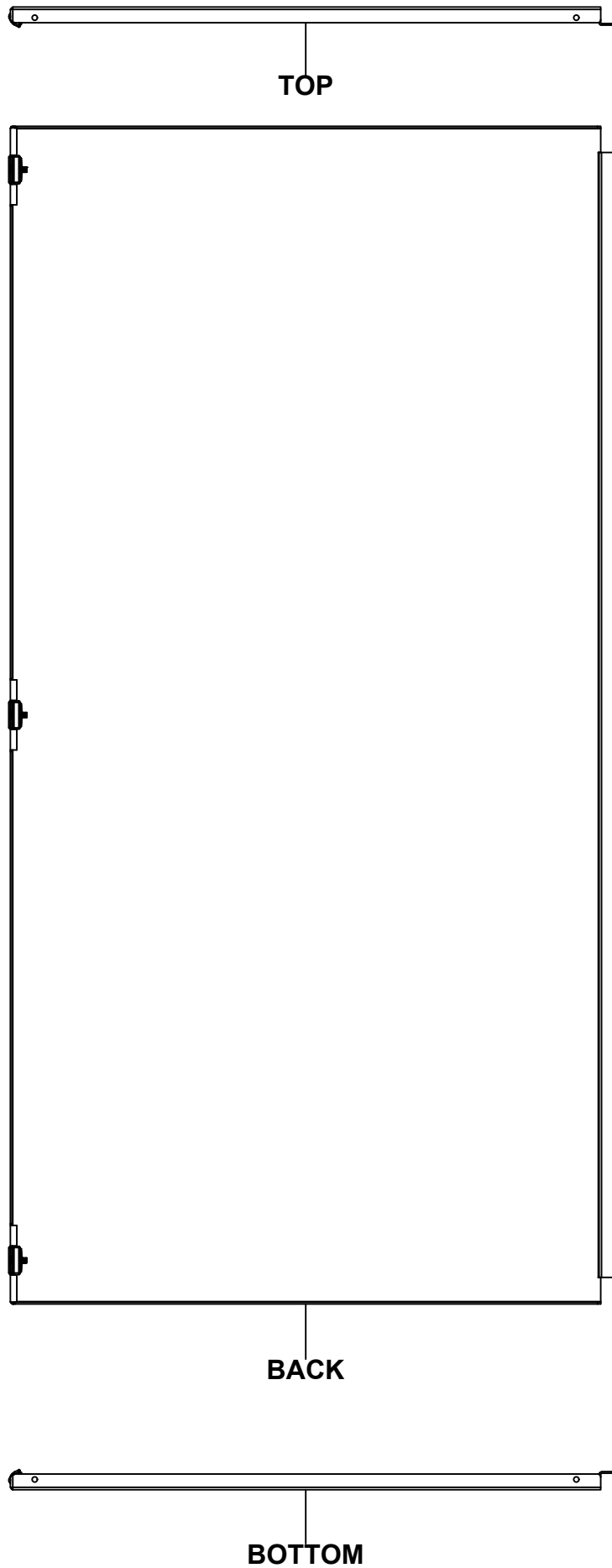

No.	Revisions	Date	By/Par

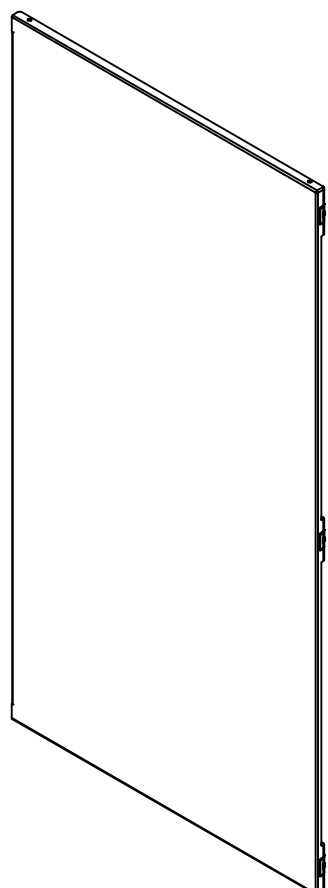

Isometric View

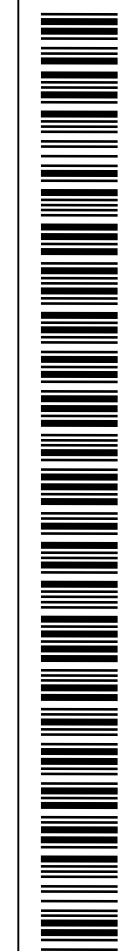

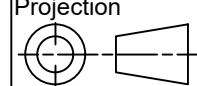
 Tél: (450) 979-4373 Fax: (450) 979-4626 www.exmweb.com		Flatness Aplatissement
		Max 3.0mm
Projection 		Date
Customer Client		Date 28-Jan-14
Drawn By Dessiné Par BoxCad: BoxCad		
Material Matière 14 Ga Cold Rolled A1008 CS Type B (1.7mm)		
Color Couleur	Asa-61 Grey	Finish Fini Smooth
Description 1100EN 48" x 48" Flange Cover		Detail Rev.
Part Number Numéro Pièce 1100EDD484812NFD		Rev. 0 / 9

SEE BILL OF MATERIAL ON LAST PAGE

This drawing is confidential and must not be reproduced or used without the consent of EXM

Ce dessin est confidentiel et ne doit pas être reproduit ou utilisé sans le consentement de EXM

No.	Revisions	Date	By/Par

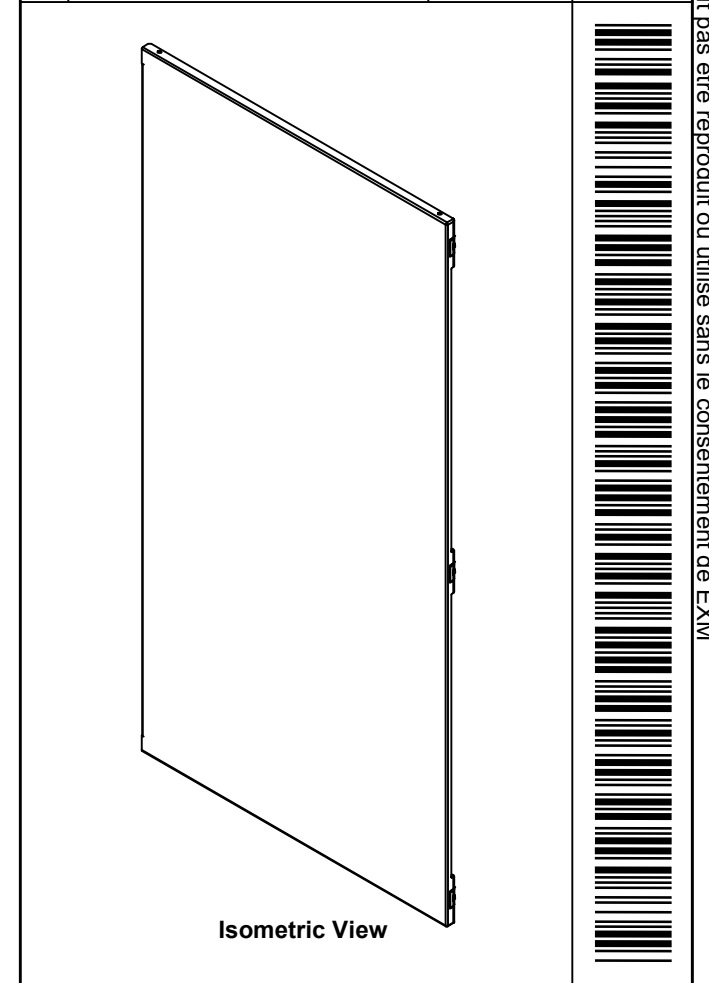

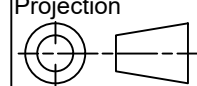
 Tél: (450) 979-4373 Fax: (450) 979-4626 www.exmweb.com		Flatness Aplatissement Max 3.0mm Projection 
Customer Client	Date	
Drawn By / Dessiné Par: BoxCad: BoxCad	Date: 28-Jan-14	
Material / Matière: 14 Ga Cold Rolled A1008 CS Type B (1.7mm)		
Color / Couleur: Asa-61 Grey	Finish / Fini: Smooth	
Description: 1100EN 48" x 48" Flange Cover		Detail Rev.
Part Number / Numéro Pièce: 1100EDD484812NFD	Rev.:	10
		0
		10

Qty	Part Number	Rev	Description
1	1100EDD484812NFC-P	0	1100EN 48" x 48" x 12" Flange Cover Part
1	STK-P-02400S	0	Powder Paint (Asa-61 Grey / Smooth)
3	STK-A-33033	4	5412 ESMCH Hinge
Parts List			