

This drawing is confidential and must not be reproduced or used without the consent of EXM

Ce dessin est confidentiel et ne doit pas être reproduit ou utilisé sans le consentement de EXM

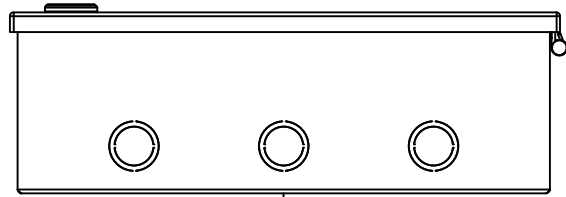

TOP

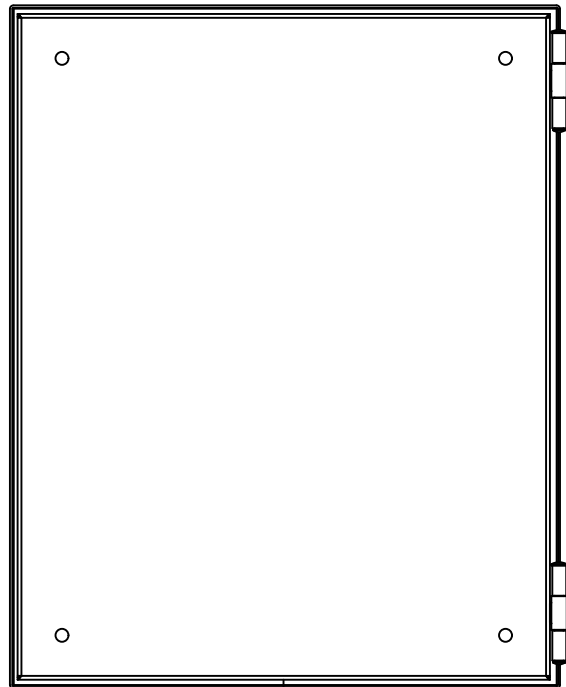

BACK

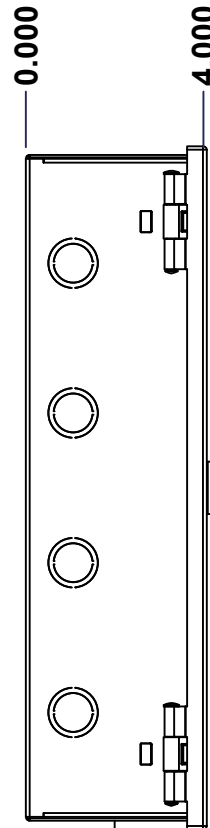

LEFT

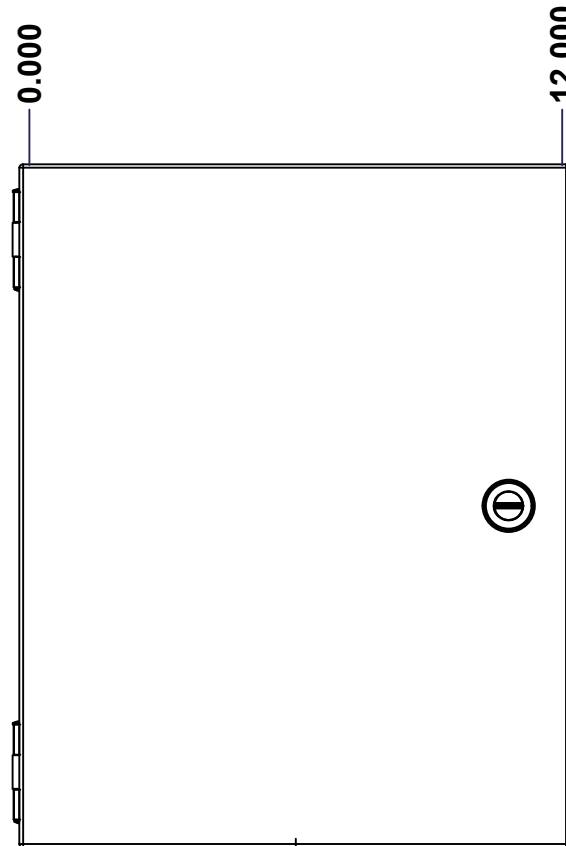

FRONT

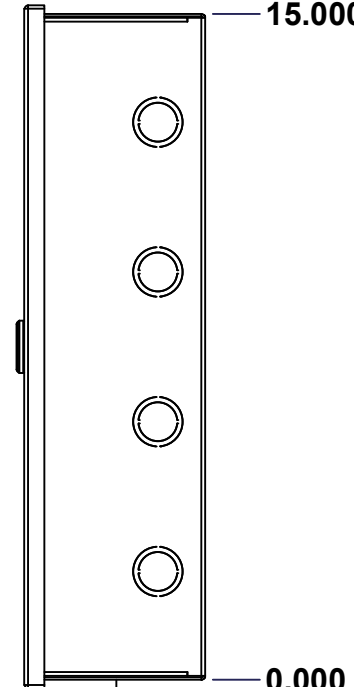

RIGHT

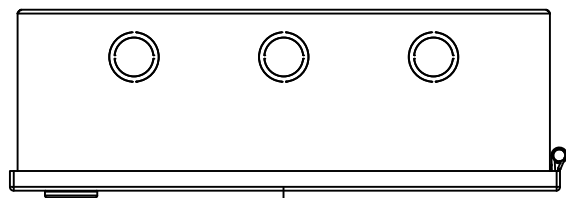

BOTTOM

No.	Revisions	Date	By/Par

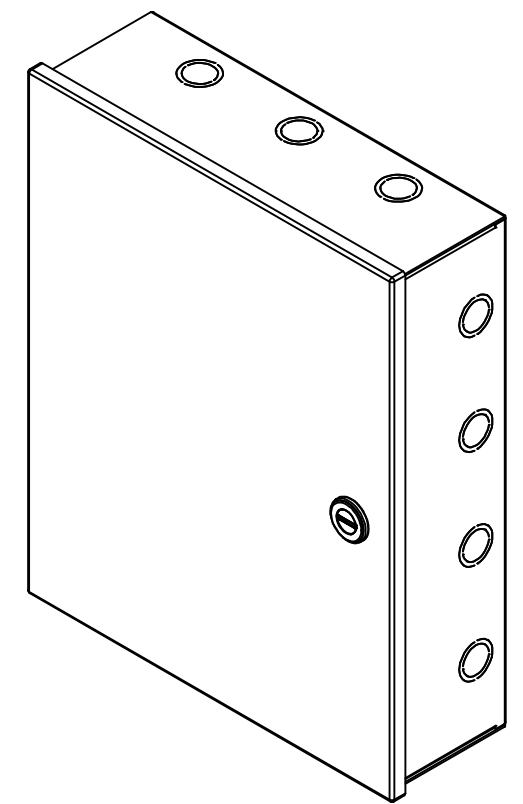

Isometric View



Tél: (450) 979-4373  
 Fax: (450) 979-4626  
[www.exmweb.com](http://www.exmweb.com)

Flatness  
 Aplatissement  
 Max 3.0mm  
 Projection

Customer Client	Date
Drawn By / Dessiné Par: BoxCad: BoxCad	Date: 04-Mar-26
Material / Matière: 16 Ga Cold Rolled A1008 CS Type B (1.4mm)	
Color / Couleur: Asa-61 Grey	Finish / Fini: Smooth

Description: 1100EH 15" x 12" x 4" Assembly	Detail Rev.
---	-------------

Part Number / Numéro Pièce: 1100EH151204	Rev. 0	1	12
--	--------	---	----

SEE BILL OF MATERIAL ON LAST PAGE

This drawing is confidential and must not be reproduced or used without the consent of EXM

Ce dessin est confidentiel et ne doit pas être reproduit ou utilisé sans le consentement de EXM

NOTE	
ITEM	DESCRIPTION
1	NEMA 1 Enclosure (IP20)
2	C/W Standard ground provision on box and cover
3	W/O Standard door stiffener
4	W/O Inner panel
5	W/O Inner panel mounting provision

No.	Revisions	Date	By/Par

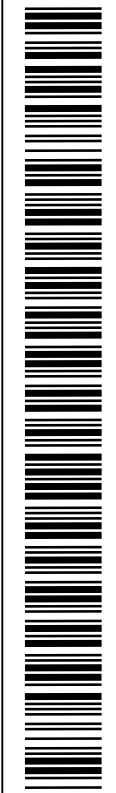
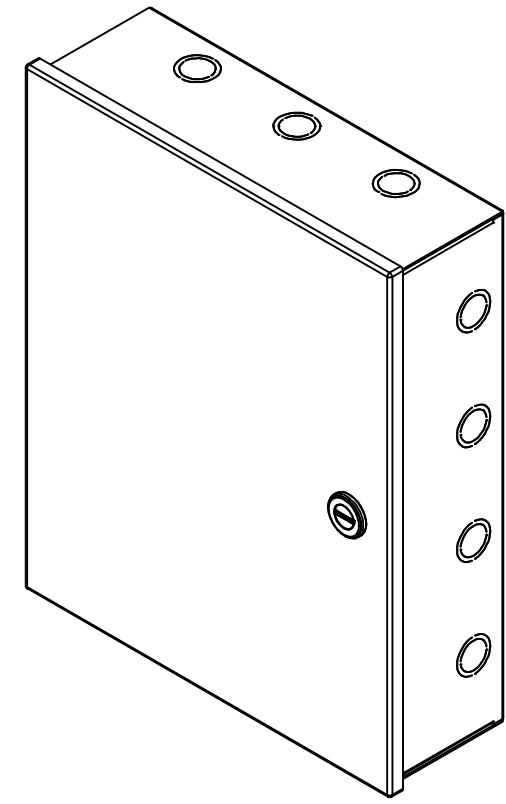

Isometric View



Tél: (450) 979-4373  
 Fax: (450) 979-4626  
[www.exmweb.com](http://www.exmweb.com)



Customer Client	Date
Drawn By / Dessiné Par: BoxCad: BoxCad	Date: 04-Mar-26
Material / Matière: 16 Ga Cold Rolled A1008 CS Type B (1.4mm)	
Color / Couleur: Asa-61 Grey	Finish / Fini: Smooth

PACKING		
ITEM	QTY	DESCRIPTION
Thermal plastic film	1	Use with Packing Tunnel Wrapper Machine
Packaging label	1	White label with product number

Qty	Part Number	Rev	Description
2	STK-A-33710	0	1100 EH Hinge - 55mm Stainless Steel Press-fit pin
1	1100EH151204C	0	1100EH 15" x 12" Cover
1	1100EH151204B	0	1100EH 15" x 12" x 4" Body
Parts List			

Description: 1100EH 15" x 12" x 4" Assembly	Detail Rev.
Part Number / Numéro Pièce: <b>1100EH151204</b>	Rev. <b>0</b> / 2

This drawing is confidential and must not be reproduced or used without the consent of EXM

Ce dessin est confidentiel et ne doit pas être reproduit ou utilisé sans le consentement de EXM

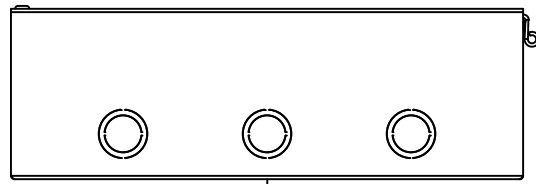

TOP

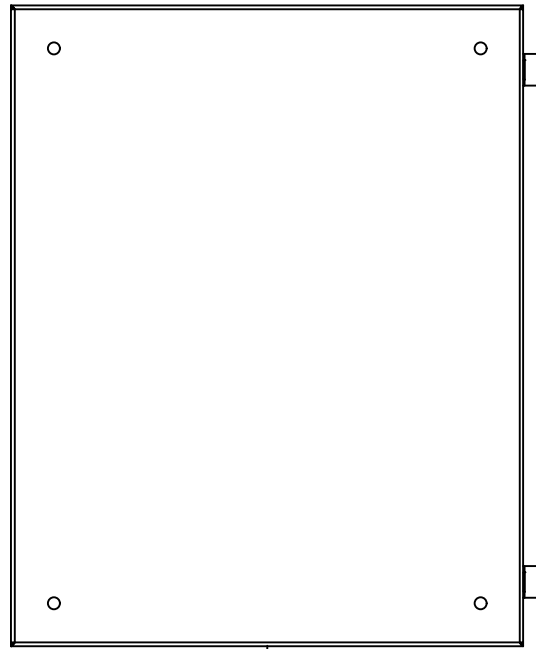

BACK

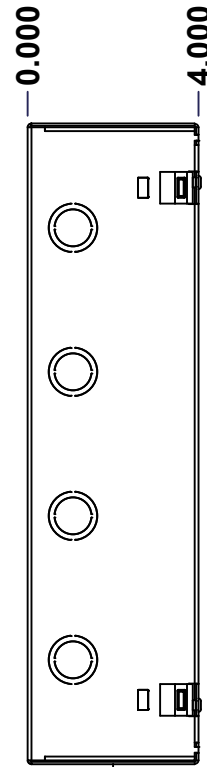

LEFT

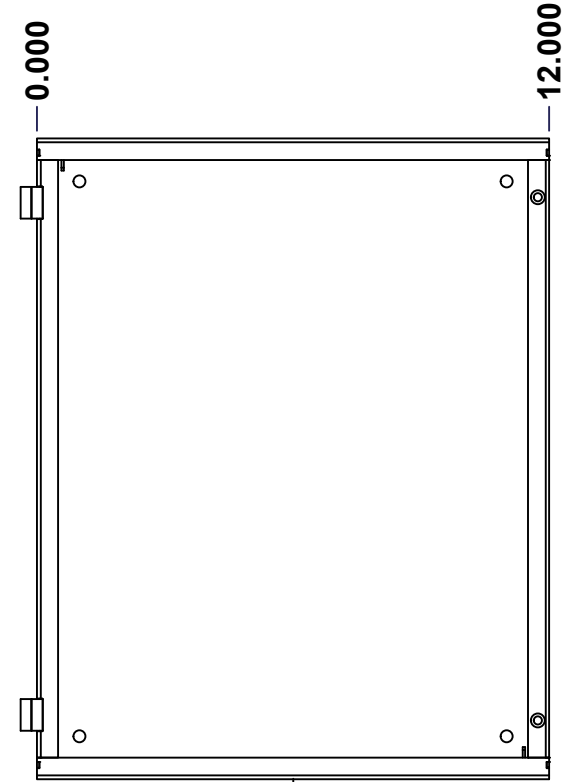

FRONT

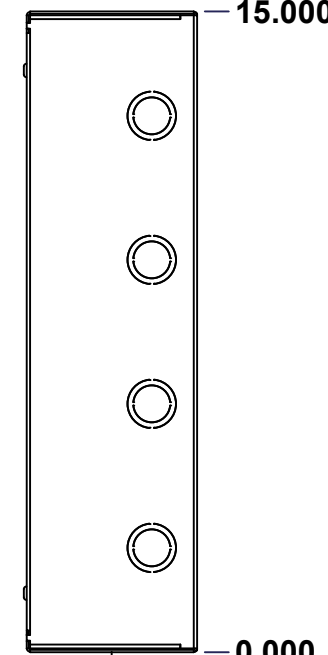

RIGHT

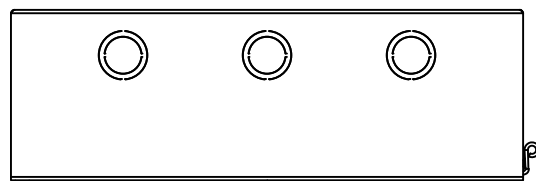

BOTTOM

No.	Revisions	Date	By/Par

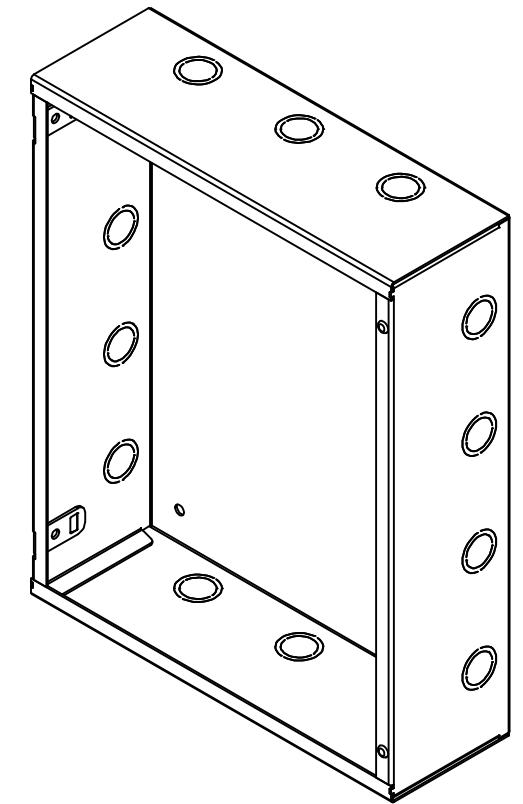

Isometric View

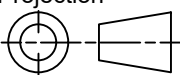

 Tél: (450) 979-4373 Fax: (450) 979-4626 <a href="http://www.exmweb.com">www.exmweb.com</a>		Flatness Aplatissement Max 3.0mm Projection 
Customer Client	Date	
Drawn By Dessiné Par	BoxCad: BoxCad	Date 04-Mar-26
Material Matière	16 Ga Cold Rolled A1008 CS Type B (1.4mm)	
Color Couleur	Asa-61 Grey	Finish Fini Smooth
Description 1100EH 15" x 12" x 4" Body		Detail Rev.
Part Number Numéro Pièce	1100EH151204B	Rev. 3 0

SEE BILL OF MATERIAL ON LAST PAGE

This drawing is confidential and must not be reproduced or used without the consent of EXM

Ce dessin est confidentiel et ne doit pas être reproduit ou utilisé sans le consentement de EXM

**STANDARD FEATURES ARE NOT LISTED IN THIS HOLE TABLE**

**HOLE TABLE - TOP VIEW (CUSTOM FEATURE ONLY)**

CUT-OUT	XDIM	YDIM	DESCRIPTION
1	2.625	1.063	DKO Ø1.125 - 0.875
2	6.000	1.063	DKO Ø1.125 - 0.875
3	9.375	1.063	DKO Ø1.125 - 0.875

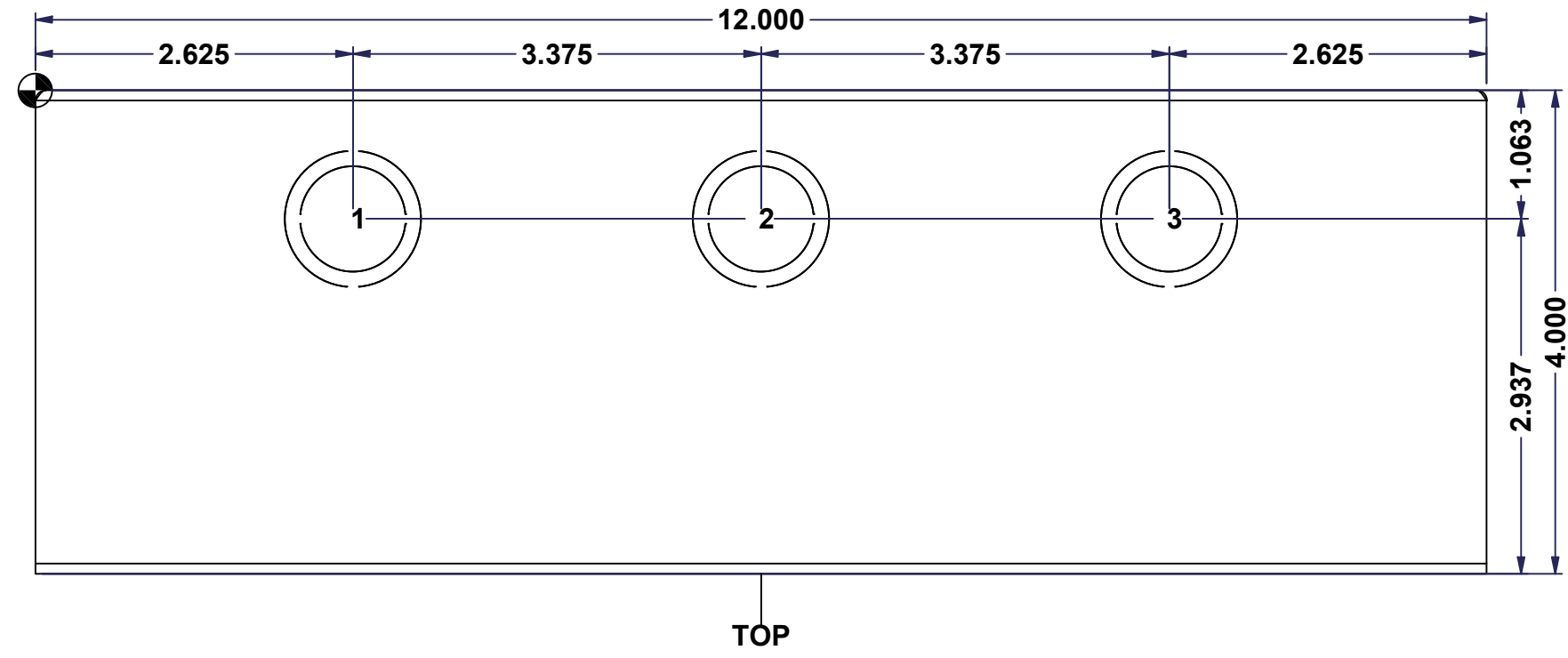

	Description 1100EH 15" x 12" x 4" Body	Status (NULL)
	Part Number Numéro Pièce <b>1100EH151204B</b>	Rev. 4 <b>0</b>

This drawing is confidential and must not be reproduced or used without the consent of EXM

Ce dessin est confidentiel et ne doit pas être reproduit ou utilisé sans le consentement de EXM

**STANDARD FEATURES ARE NOT LISTED IN THIS HOLE TABLE**

**HOLE TABLE - RIGHT VIEW (CUSTOM FEATURE ONLY)**

CUT-OUT	XDIM	YDIM	DESCRIPTION
1	1.063	2.438	DKO Ø1.125 - 0.875
2	1.063	5.812	DKO Ø1.125 - 0.875
3	1.063	9.188	DKO Ø1.125 - 0.875
4	1.063	12.562	DKO Ø1.125 - 0.875

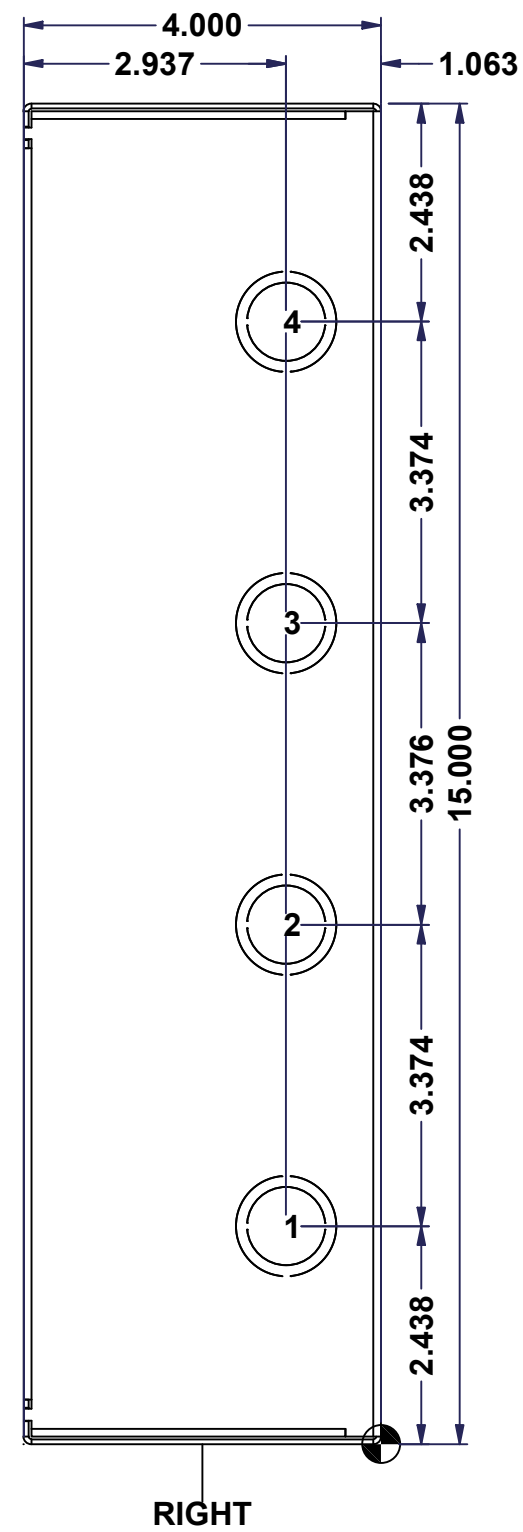

	Description 1100EH 15" x 12" x 4" Body	Status (NULL)
	Part Number Numéro Pièce <b>1100EH151204B</b>	Rev. 5 <b>0</b>

This drawing is confidential and must not be reproduced or used without the consent of EXM

Ce dessin est confidentiel et ne doit pas être reproduit ou utilisé sans le consentement de EXM

**STANDARD FEATURES ARE NOT LISTED IN THIS HOLE TABLE**

**HOLE TABLE - BOTTOM VIEW (CUSTOM FEATURE ONLY)**

CUT-OUT	XDIM	YDIM	DESCRIPTION
1	2.625	1.063	DKO Ø1.125 - 0.875
2	6.000	1.063	DKO Ø1.125 - 0.875
3	9.375	1.063	DKO Ø1.125 - 0.875

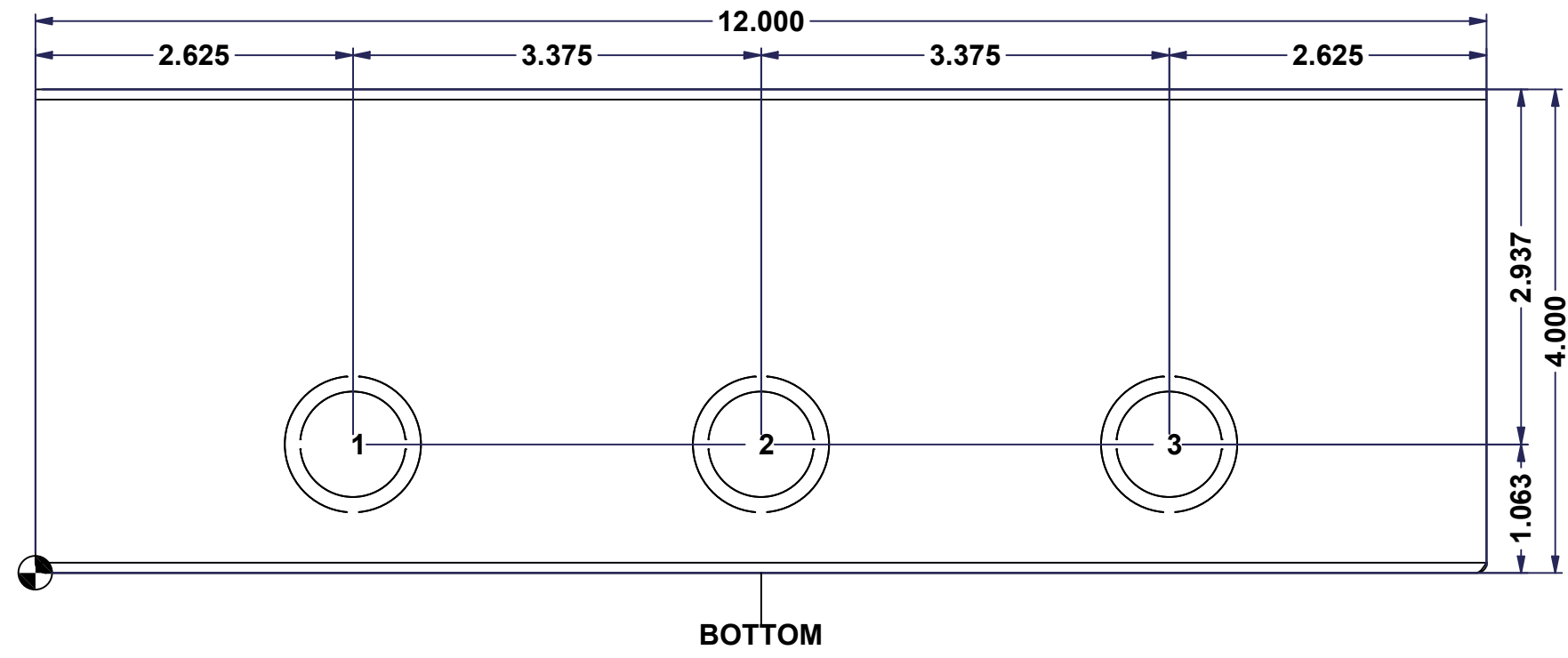

	Description 1100EH 15" x 12" x 4" Body	Status (NULL)
	Part Number Numéro Pièce <b>1100EH151204B</b>	Rev. 6 <b>0</b>

This drawing is confidential and must not be reproduced or used without the consent of EXM

Ce dessin est confidentiel et ne doit pas être reproduit ou utilisé sans le consentement de EXM

**STANDARD FEATURES ARE NOT LISTED IN THIS HOLE TABLE**

**HOLE TABLE - LEFT VIEW (CUSTOM FEATURE ONLY)**

CUT-OUT	XDIM	YDIM	DESCRIPTION
1	1.063	2.438	DKO Ø1.125 - 0.875
2	1.063	5.812	DKO Ø1.125 - 0.875
3	1.063	9.188	DKO Ø1.125 - 0.875
4	1.063	12.562	DKO Ø1.125 - 0.875

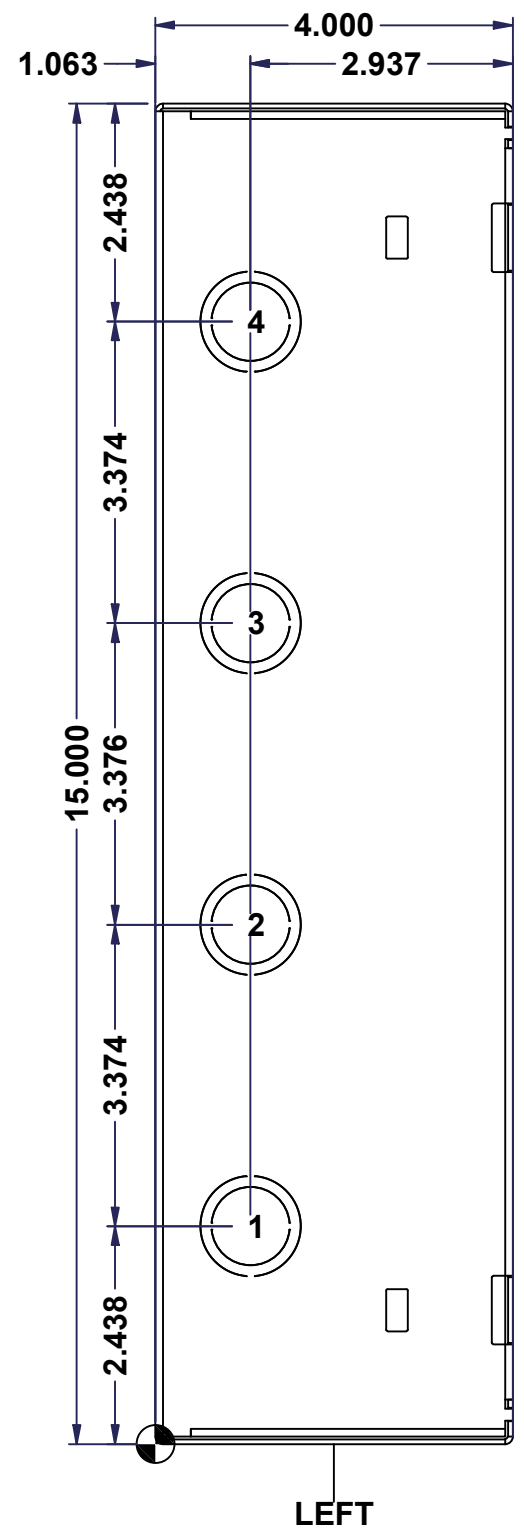

LEFT

	Description	Status	
	1100EH 15" x 12" x 4" Body	(NULL)	
	Part Number Numéro Pièce	Rev.	7
	<b>1100EH151204B</b>	<b>0</b>	12

This drawing is confidential and must not be reproduced or used without the consent of EXM

Ce dessin est confidentiel et ne doit pas être reproduit ou utilisé sans le consentement de EXM

**STANDARD FEATURES ARE NOT LISTED IN THIS HOLE TABLE**

**HOLE TABLE - BACK VIEW (CUSTOM FEATURE ONLY)**

CUT-OUT	XDIM	YDIM	DESCRIPTION
1	1.000	1.000	RND Ø0.290
2	1.000	14.000	RND Ø0.290
3	11.000	1.000	RND Ø0.290
4	11.000	14.000	RND Ø0.290

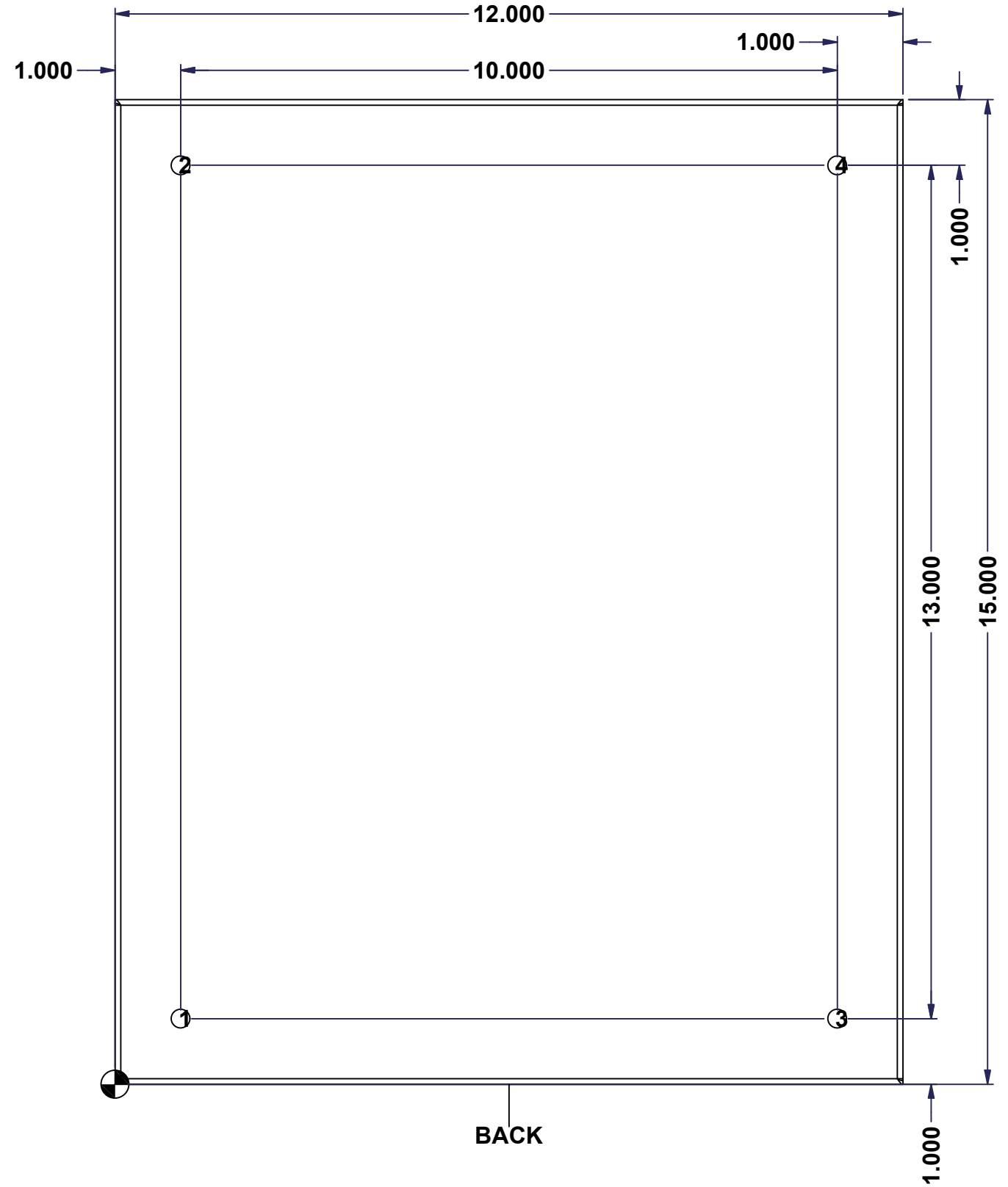

BACK

	Description	Status	
	1100EH 15" x 12" x 4" Body	(NULL)	
	Part Number	Rev.	8
	Numéro Pièce	<b>0</b>	12
	<b>1100EH151204B</b>		

This drawing is confidential and must not be reproduced or used without the consent of EXM

Ce dessin est confidentiel et ne doit pas être reproduit ou utilisé sans le consentement de EXM

No.	Revisions	Date	By/Par

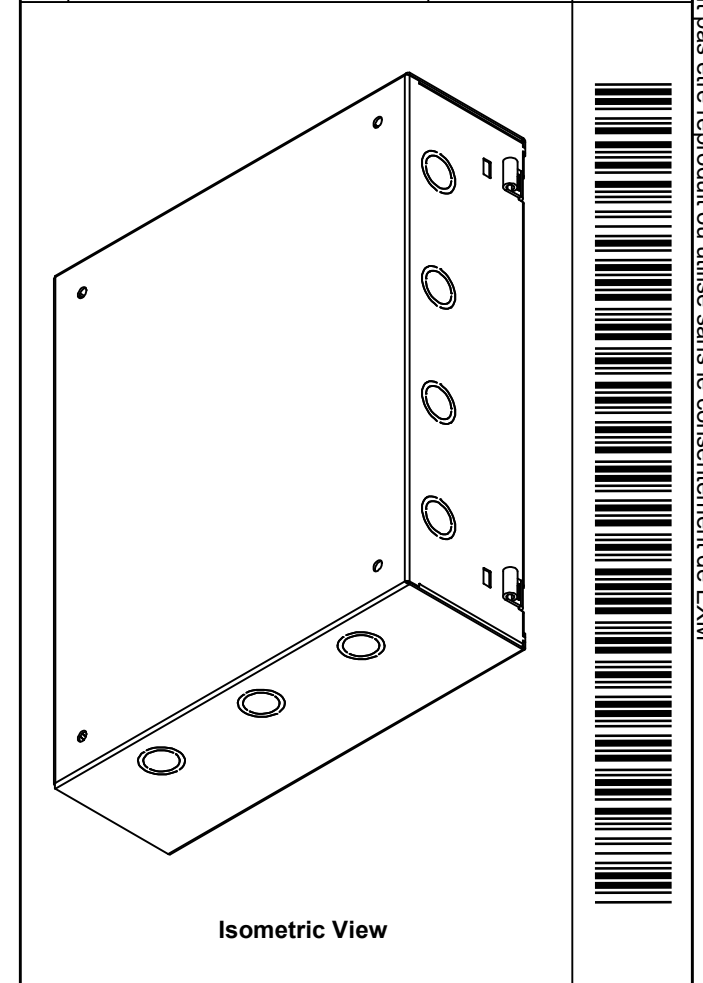

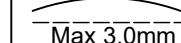
 Tél: (450) 979-4373 Fax: (450) 979-4626 <a href="http://www.exmweb.com">www.exmweb.com</a>		Flatness Aplatissement  Max 3.0mm
Customer Client		Date
Drawn By / Dessiné Par: BoxCad: BoxCad		Date: 04-Mar-26
Material / Matière: 16 Ga Cold Rolled A1008 CS Type B (1.4mm)		
Color / Couleur: Asa-61 Grey	Finish / Fini: Smooth	
Description: 1100EH 15" x 12" x 4" Body		Detail Rev.
Part Number / Numéro Pièce: <b>1100EH151204B</b>		Rev. 9 <b>0</b>

Qty	Part Number	Rev	Description
1	STK-P-02400S	0	Powder Paint (Asa-61 Grey / Smooth)
2	STK-Q-77110	1	5412 ES Cover Plastic Plug
2	STK-Q-33410-P	5	1100 MC Left Side Hinge
1	1100EH151204B-P	0	1100EH 15" x 12" x 4" Body Part
Parts List			

This drawing is confidential and must not be reproduced or used without the consent of EXM

Ce dessin est confidentiel et ne doit pas être reproduit ou utilisé sans le consentement de EXM

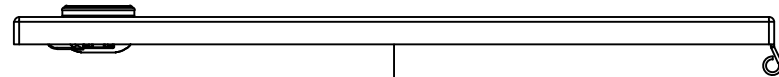

TOP

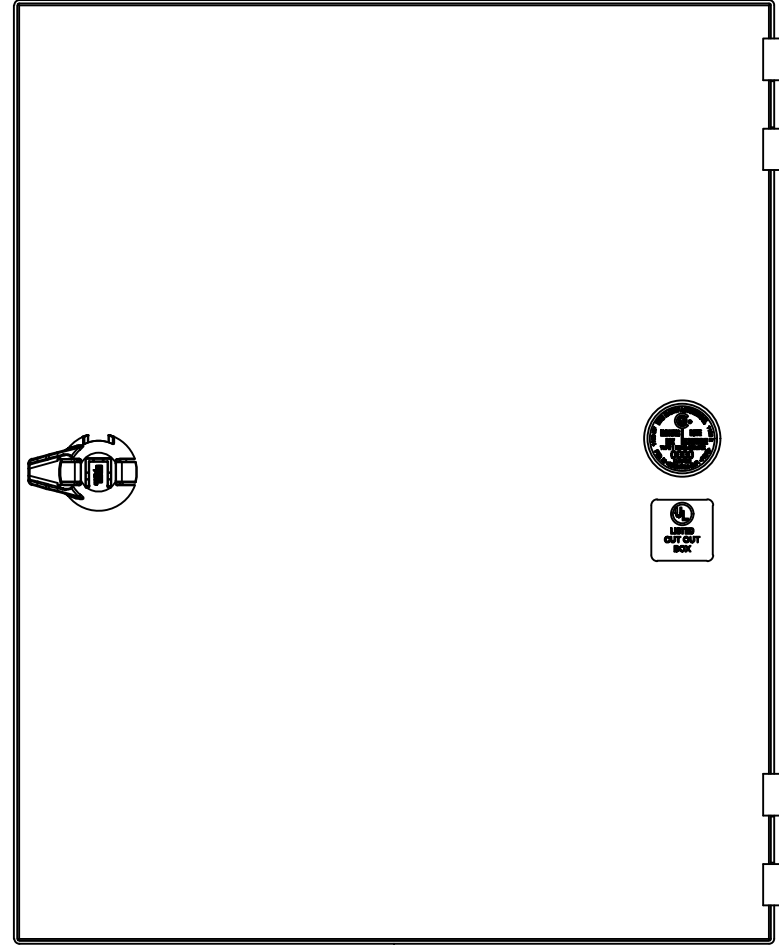

BACK

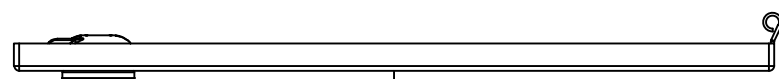

BOTTOM

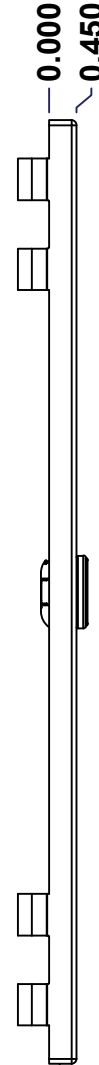

LEFT

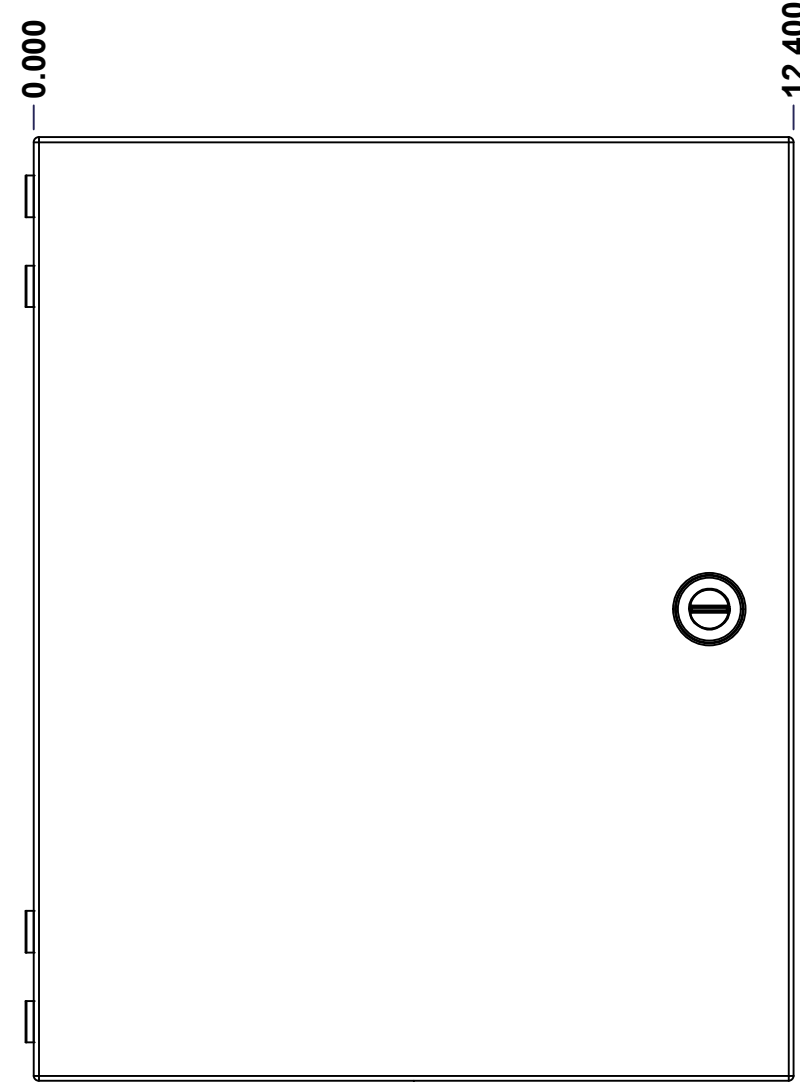

FRONT

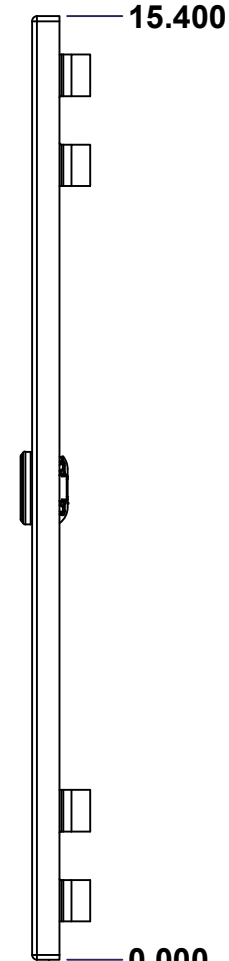

RIGHT

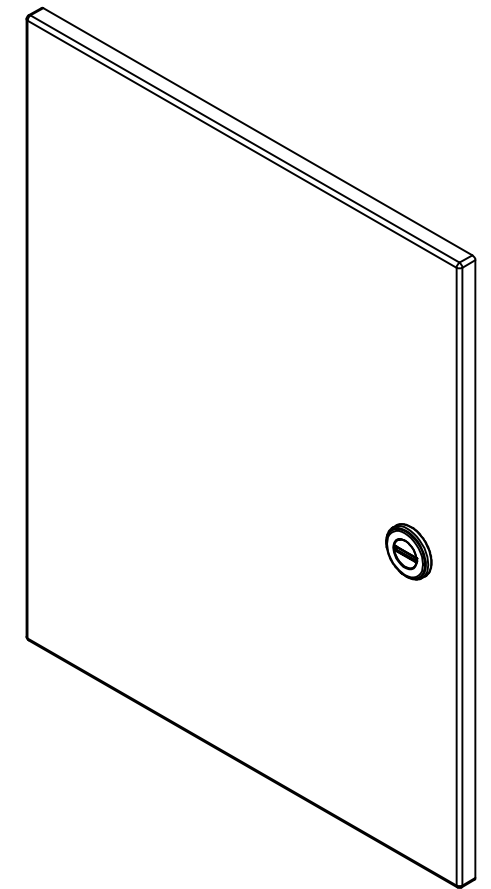

Isometric View

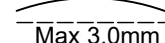
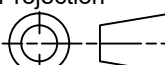

No.	Revisions	Date	By/Par

 Tél: (450) 979-4373 Fax: (450) 979-4626 <a href="http://www.exmweb.com">www.exmweb.com</a>		Flatness Aplatissement  Max 3.0mm Projection 
Customer Client	Date	
Drawn By Dessiné Par	BoxCad: BoxCad	Date 04-Mar-26
Material Matière	16 Ga Cold Rolled A1008 CS Type B (1.4mm)	
Color Couleur	Asa-61 Grey	Finish Fini Smooth
Description	Detail Rev.	
1100EH 15" x 12" Cover		
Part Number Numéro Pièce	Rev. 0	10 12

SEE BILL OF MATERIAL ON LAST PAGE

**1100EH151204C**

This drawing is confidential and must not be reproduced or used without the consent of EXM

Ce dessin est confidentiel et ne doit pas être reproduit ou utilisé sans le consentement de EXM

**STANDARD FEATURES ARE NOT LISTED IN THIS HOLE TABLE**

**HOLE TABLE - FRONT VIEW (CUSTOM FEATURE ONLY)**

CUT-OUT	XDIM	YDIM	DESCRIPTION
1	11.025	7.700	LOCK 880 SCQ1-SL @ 0.0°

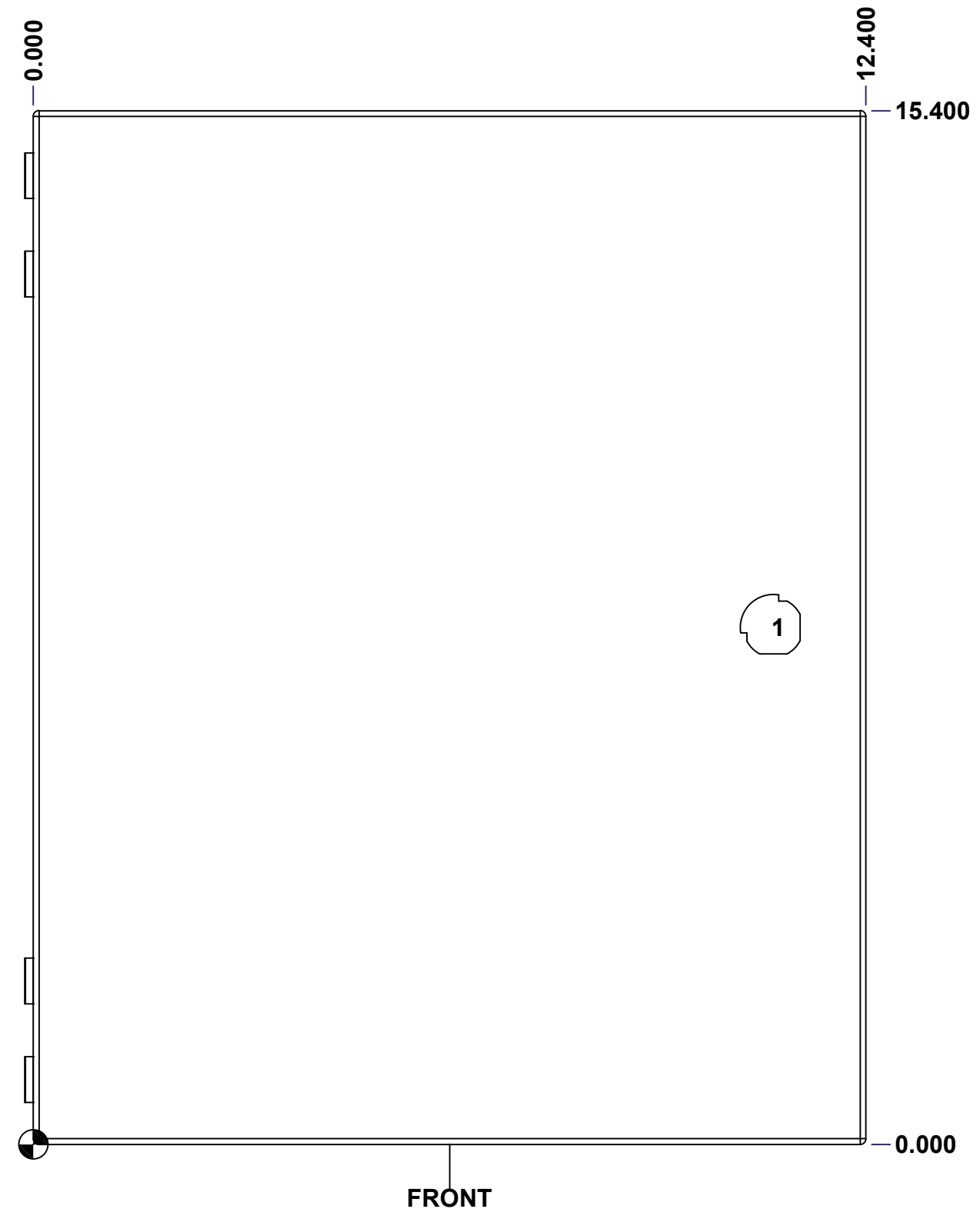

	Description	Status	
	1100EH 15" x 12" Cover	(NULL)	
	Part Number Numéro Pièce	Rev.	11
	<b>1100EH151204C</b>	<b>0</b>	12

This drawing is confidential and must not be reproduced or used without the consent of EXM

Ce dessin est confidentiel et ne doit pas être reproduit ou utilisé sans le consentement de EXM

No.	Revisions	Date	By/Par

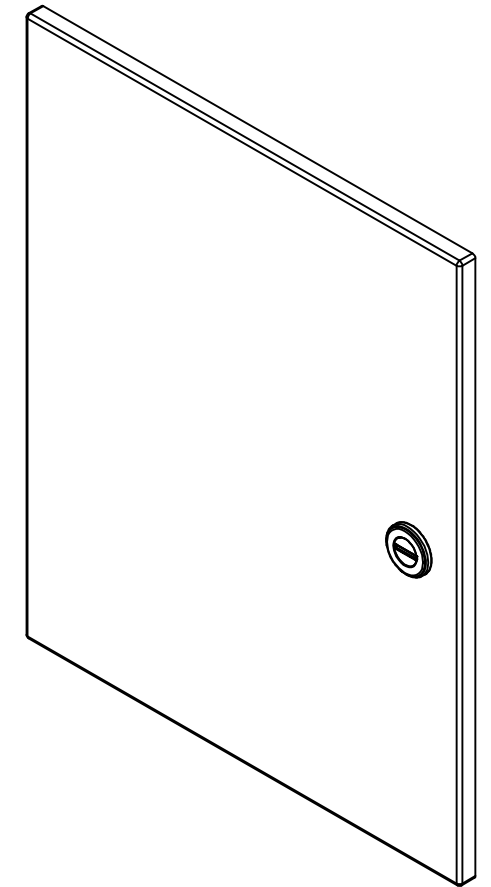

Isometric View

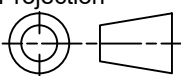

 Tél: (450) 979-4373 Fax: (450) 979-4626 <a href="http://www.exmweb.com">www.exmweb.com</a>		Flatness Aplatissement Max 3.0mm Projection 
Customer Client	Date	
Drawn By / Dessiné Par: BoxCad: BoxCad	Date: 04-Mar-26	
Material / Matière: 16 Ga Cold Rolled A1008 CS Type B (1.4mm)		
Color / Couleur: Asa-61 Grey	Finish / Fini: Smooth	
Description: 1100EH 15" x 12" Cover		Detail Rev.
Part Number / Numéro Pièce: <b>1100EH151204C</b>	Rev.: <b>0</b>	12 / 12

QTY	Part Number	Rev	Description
1	880 SCQ1-SL	0	1100 1/4 Turn Lock
1	STK-P-02400S	0	Powder Paint (Asa-61 Grey / Smooth)
1	STK-S-00900	0	UL Cut-Out Box Sticker
1	STK-S-00800	2	CSA Electrical Box Sticker
1	1100EH151204C-P	0	1100EH 15" x 12" x 4" Cover Part
Parts List			