

This drawing is confidential and must not be reproduced or used without the consent of EXM

Ce dessin est confidentiel et ne doit pas être reproduit ou utilisé sans le consentement de EXM

**APPROVED FOR PRODUCTION**  
**APPROUVÉ POUR PRODUCTION**  
 SIGNATURE: \_\_\_\_\_  
 NAME / NOM: \_\_\_\_\_  
 DATE: \_\_\_\_\_  
 Please visit: [www.boxcadexm.com](http://www.boxcadexm.com)

No.	Revisions	Date	By/Par

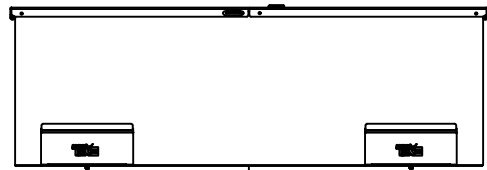

TOP

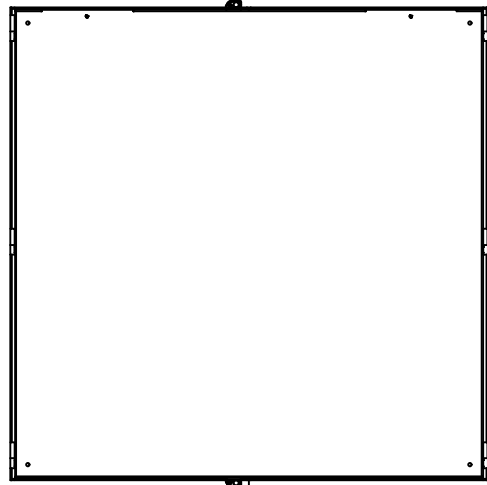

BACK



BOTTOM

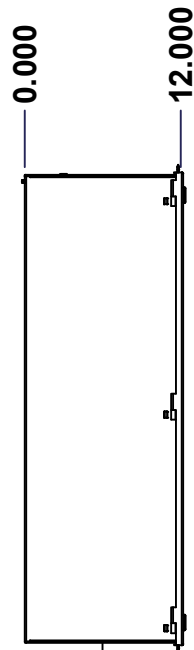

LEFT

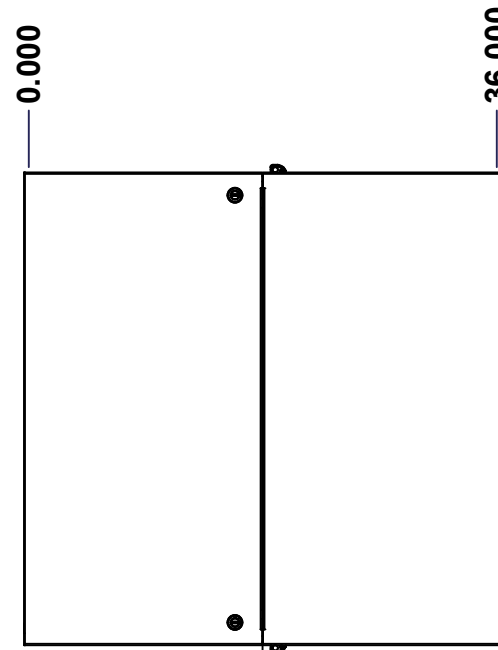

FRONT

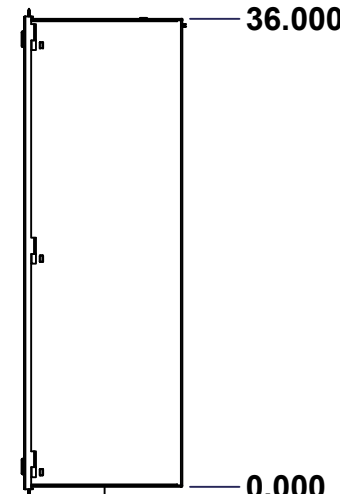

RIGHT

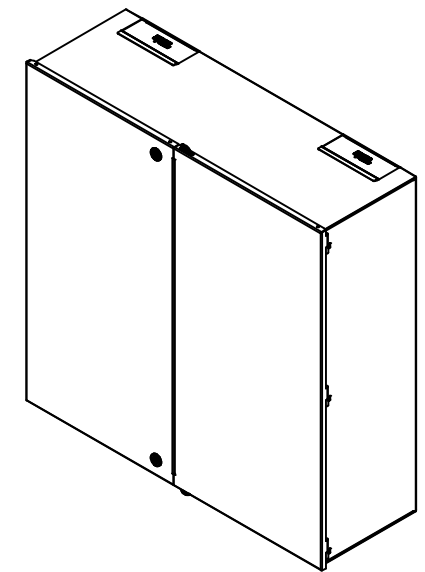

Isometric View

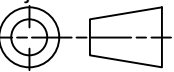

 Tél: (450) 979-4373 Fax: (450) 979-4626 <a href="http://www.exmweb.com">www.exmweb.com</a>	Flatness Aplatissement	Max 3.0mm
	Projection	
Customer Client	Date	
Drawn By Dessiné Par	BoxCad: patsan	Date 30-Nov-22
Material Matière	14 Ga Cold Rolled A1008 CS Type B (1.7mm)	
Color Couleur	Asa-61 Grey	Finish Fini Smooth
Description	Detail Rev.	
1100MCDD 36" x 36" x 12" Assembly		
Part Number Numéro Pièce	Rev.	1
1100MCDD363612	0	11

SEE BILL OF MATERIAL ON LAST PAGE

This drawing is confidential and must not be reproduced or used without the consent of EXM

Ce dessin est confidentiel et ne doit pas être reproduit ou utilisé sans le consentement de EXM

NOTE	
ITEM	DESCRIPTION
1	NEMA 1 Enclosure (IP20)
2	C/W Inner panel (Included)
3	C/W Standard inner panel mounting studs

**APPROVED FOR PRODUCTION**  
**APPROUVÉ POUR PRODUCTION**  
 SIGNATURE: \_\_\_\_\_  
 NAME / NOM: \_\_\_\_\_  
 DATE: \_\_\_\_\_  
 Please visit: [www.boxcadexm.com](http://www.boxcadexm.com)

No.	Revisions	Date	By/Par

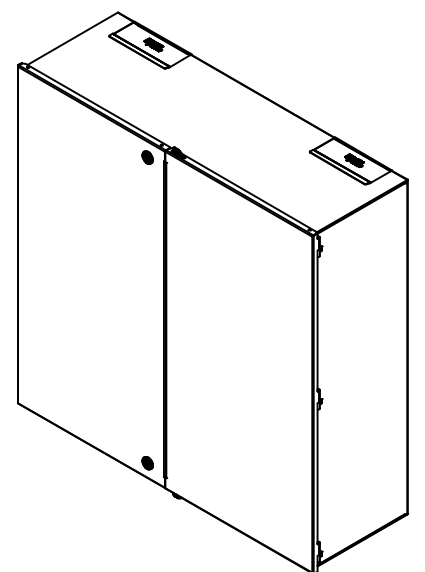

Isometric View

**EXM**  
 Tél: (450) 979-4373  
 Fax: (450) 979-4626  
[www.exmweb.com](http://www.exmweb.com)

Flatness  
 Aplatissement  
 Max 3.0mm  
 Projection

Customer Client	Date
Drawn By / Dessiné Par: BoxCad: patsan	Date: 30-Nov-22
Material / Matière: 14 Ga Cold Rolled A1008 CS Type B (1.7mm)	

Color / Couleur: Asa-61 Grey	Finish / Fini: Smooth
Description: 1100MCDD 36" x 36" x 12" Assembly	Detail Rev.
Part Number / Numéro Pièce: <b>1100MCDD363612</b>	Rev. 0

PACKING		
ITEM	QTY	DESCRIPTION
Cardboard sleeve	2	Top and Bottom
Cardboard strip	2	Between back of enclosure and inner panel
Plastic bag	1	To protect cover surface and inside gasket
Plastic strap - Black	2	To Squeeze the 2 cardboard sleeve together
Packaging label	1	White label with product number

Qty	Part Number	Rev	Description
1	1100MCDD363612IP	0	1100MCDD 36" x 36" Inner Panel
16	STK-Q-07310	3	Flange Lock Nut M8
2	STK-Q-05020	5	M5 x 8mm Thread Rolling Screw
2	STK-Q-79000	5	1100MC Cover Plate
1	1100MCDD363612FD	0	1100MCDD 36" x 36" Cover
1	1100MCDD363612LD	0	1100MCDD 36" x 36" Cover
1	1100MCDD363612B	0	1100MCDD 36" x 36" x 12" Body

Parts List

This drawing is confidential and must not be reproduced or used without the consent of EXM

Ce dessin est confidentiel et ne doit pas être reproduit ou utilisé sans le consentement de EXM

**APPROVED FOR PRODUCTION**  
**APPROUVÉ POUR PRODUCTION**  
 SIGNATURE: \_\_\_\_\_  
 NAME / NOM: \_\_\_\_\_  
 DATE: \_\_\_\_\_  
 Please visit: [www.boxcadexm.com](http://www.boxcadexm.com)

No.	Revisions	Date	By/Par

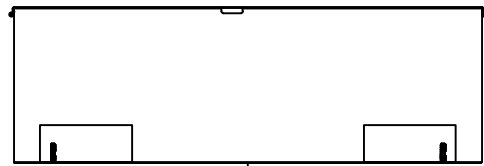

TOP

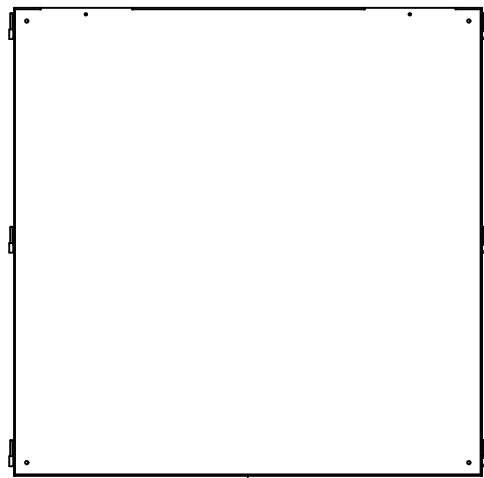

BACK

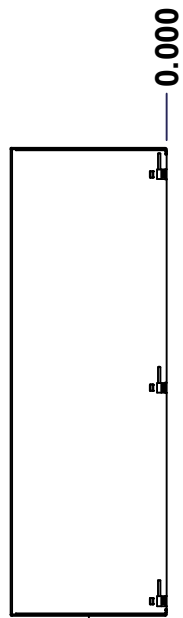

LEFT

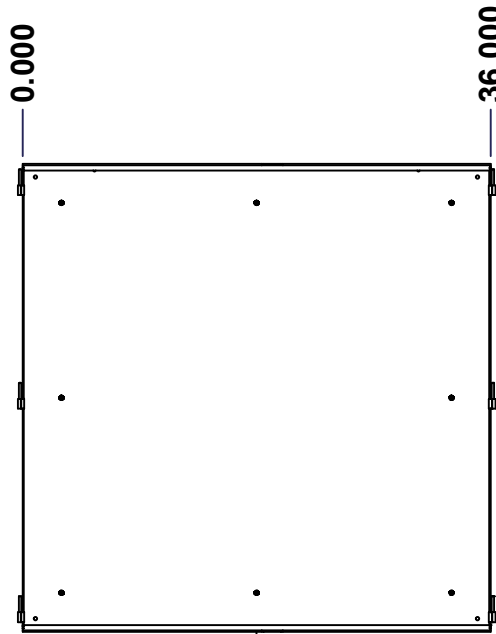

FRONT

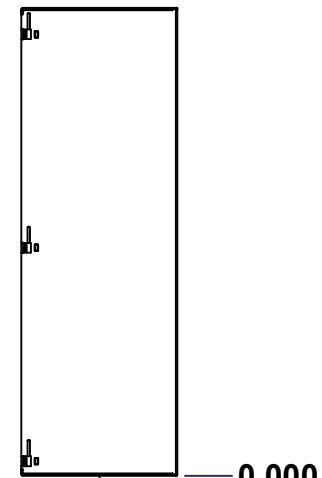

RIGHT

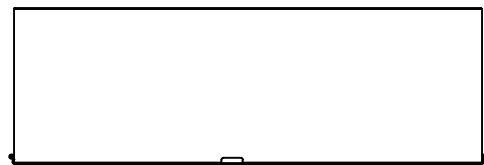

BOTTOM

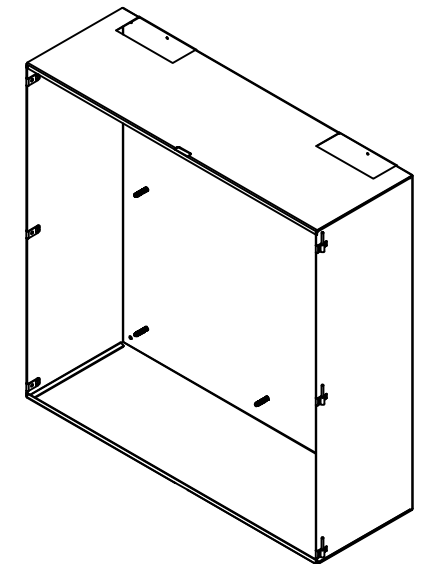

Isometric View

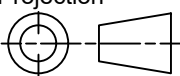

 Tél: (450) 979-4373 Fax: (450) 979-4626 <a href="http://www.exmweb.com">www.exmweb.com</a>	Flatness Aplatissement	Max 3.0mm
	Projection	
Customer Client	Date	
Drawn By Dessiné Par	BoxCad: patsan	Date 30-Nov-22
Material Matière	14 Ga Cold Rolled A1008 CS Type B (1.7mm)	
Color Couleur	Asa-61 Grey	Finish Fini Smooth
Description	Detail Rev.	
1100MCDD 36" x 36" x 12" Body		
Part Number Numéro Pièce	Rev. 0	3 / 11
<b>1100MCDD363612B</b>		

SEE BILL OF MATERIAL ON LAST PAGE

This drawing is confidential and must not be reproduced or used without the consent of EXM

Ce dessin est confidentiel et ne doit pas être reproduit ou utilisé sans le consentement de EXM

**STANDARD FEATURES ARE NOT LISTED IN THIS HOLE TABLE**

**HOLE TABLE - BACK VIEW (CUSTOM FEATURE ONLY)**

CUT-OUT	XDIM	YDIM	DESCRIPTION
1	3.000	3.000	IP STUD M8 x 35mm (Inside)
2	3.000	33.000	IP STUD M8 x 35mm (Inside)
3	33.000	33.000	IP STUD M8 x 35mm (Inside)
4	33.000	3.000	IP STUD M8 x 35mm (Inside)
5	3.000	18.000	IP STUD M8 x 35mm (Inside)
6	33.000	18.000	IP STUD M8 x 35mm (Inside)
7	18.000	3.000	IP STUD M8 x 35mm (Inside)
8	18.000	33.000	IP STUD M8 x 35mm (Inside)
-----			
9	35.000	1.000	RND Ø0.290
10	35.000	35.000	RND Ø0.290
11	1.000	35.000	RND Ø0.290
12	1.000	1.000	RND Ø0.290

**APPROVED FOR PRODUCTION**  
**APPROUVÉ POUR PRODUCTION**  
 SIGNATURE: \_\_\_\_\_  
 NAME / NOM: \_\_\_\_\_  
 DATE: \_\_\_\_\_  
 Please visit: [www.boxcadexm.com](http://www.boxcadexm.com)

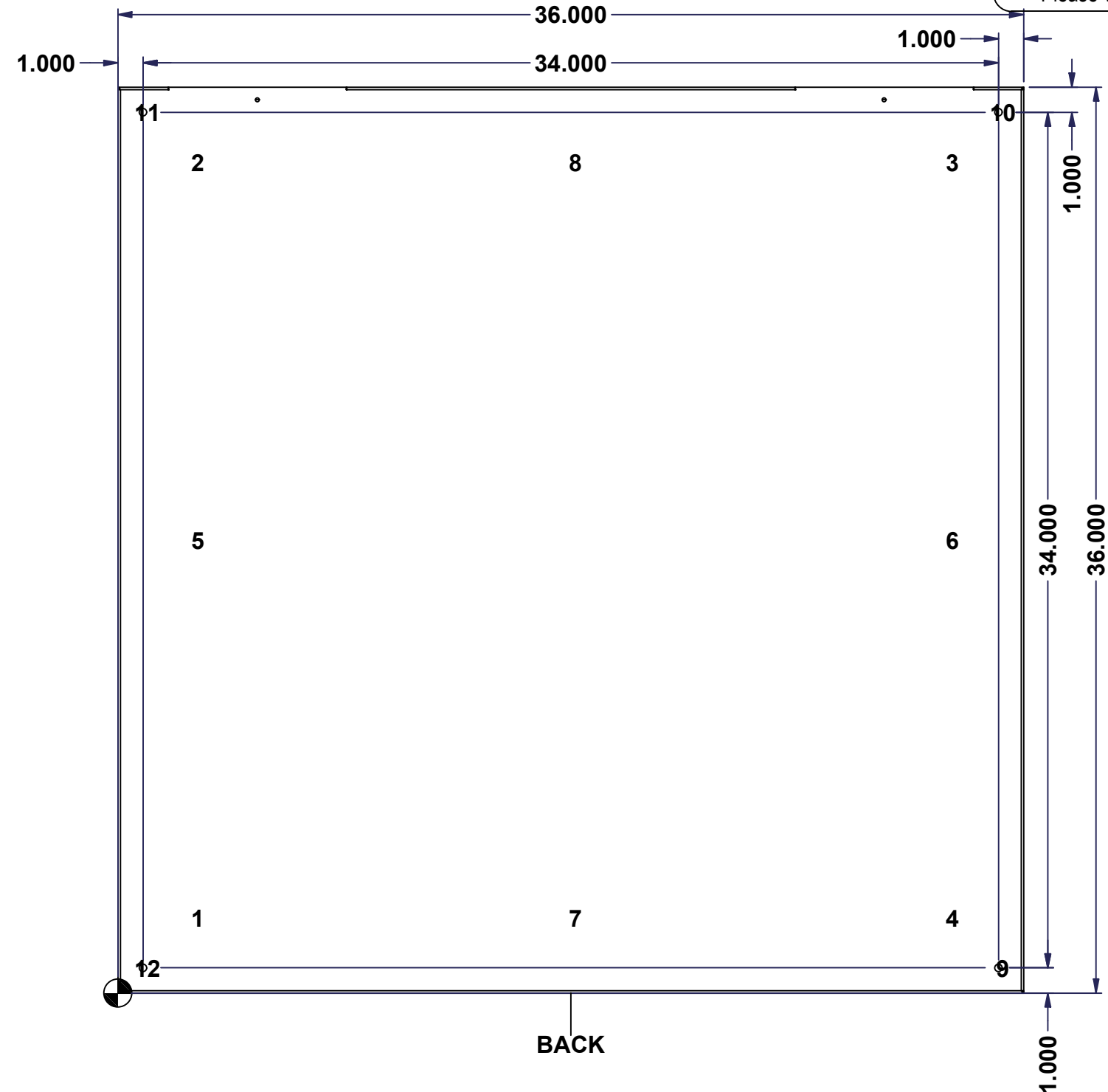

	Description	Status	
	1100MCDD 36" x 36" x 12" Body	(NULL)	
	Part Number Numéro Pièce	Rev.	4
	<b>1100MCDD363612B</b>	<b>0</b>	11

This drawing is confidential and must not be reproduced or used without the consent of EXM

Ce dessin est confidentiel et ne doit pas être reproduit ou utilisé sans le consentement de EXM

**APPROVED FOR PRODUCTION**  
**APPROUVÉ POUR PRODUCTION**  
 SIGNATURE: \_\_\_\_\_  
 NAME / NOM: \_\_\_\_\_  
 DATE: \_\_\_\_\_  
 Please visit: [www.boxcadexm.com](http://www.boxcadexm.com)

No.	Revisions	Date	By/Par

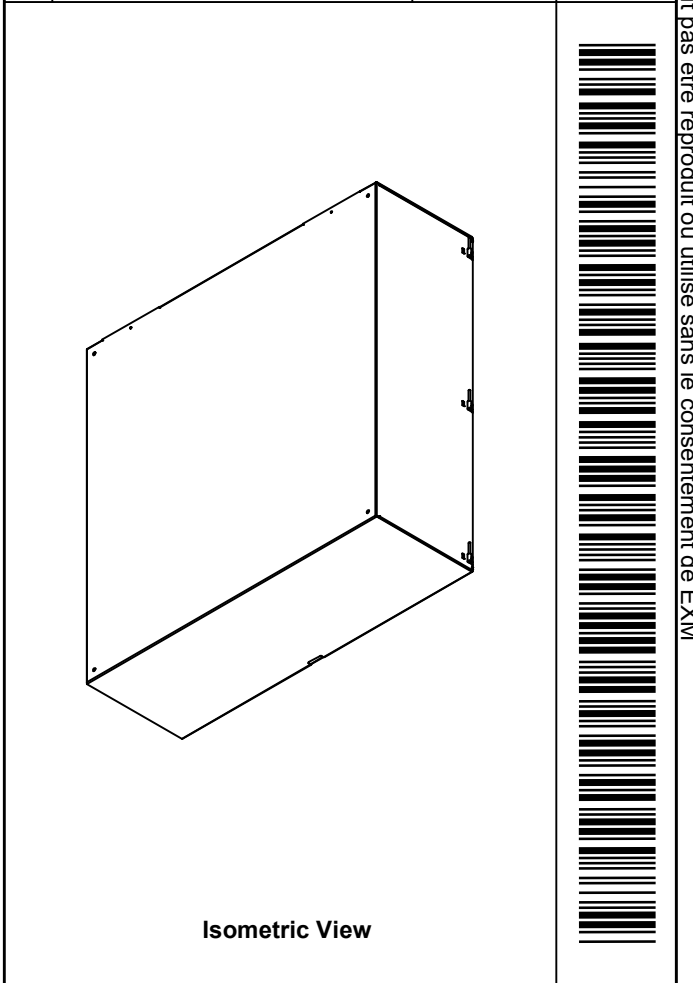

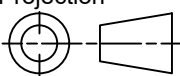
 Tél: (450) 979-4373 Fax: (450) 979-4626 <a href="http://www.exmweb.com">www.exmweb.com</a>		Flatness Aplatissement Max 3.0mm Projection 
Customer Client	Date	
Drawn By Dessiné Par	BoxCad: patsan	Date 30-Nov-22
Material Matière	14 Ga Cold Rolled A1008 CS Type B (1.7mm)	
Color Couleur	Asa-61 Grey	Finish Fini Smooth
Description		Detail Rev.
1100MCDD 36" x 36" x 12" Body		
Part Number Numéro Pièce	Rev.	5
<b>1100MCDD363612B</b>	<b>0</b>	11

Qty	Part Number	Rev	Description
1	STK-P-02400S	0	Powder Paint (Asa-61 Grey / Smooth)
8	STK-Q-16005	1	Stud M8 x 35mm (No Paint Cap Required)
1	1100MCDD363612B-P	0	1100MCDD 36" x 36" x 12" Body Part
3	STK-A-33410	7	1100 MC Left Side Hinge Assembly
3	STK-A-33510	7	1100 MC Right Side Hinge Part
Parts List			

This drawing is confidential and must not be reproduced or used without the consent of EXM

Ce dessin est confidentiel et ne doit pas être reproduit ou utilisé sans le consentement de EXM

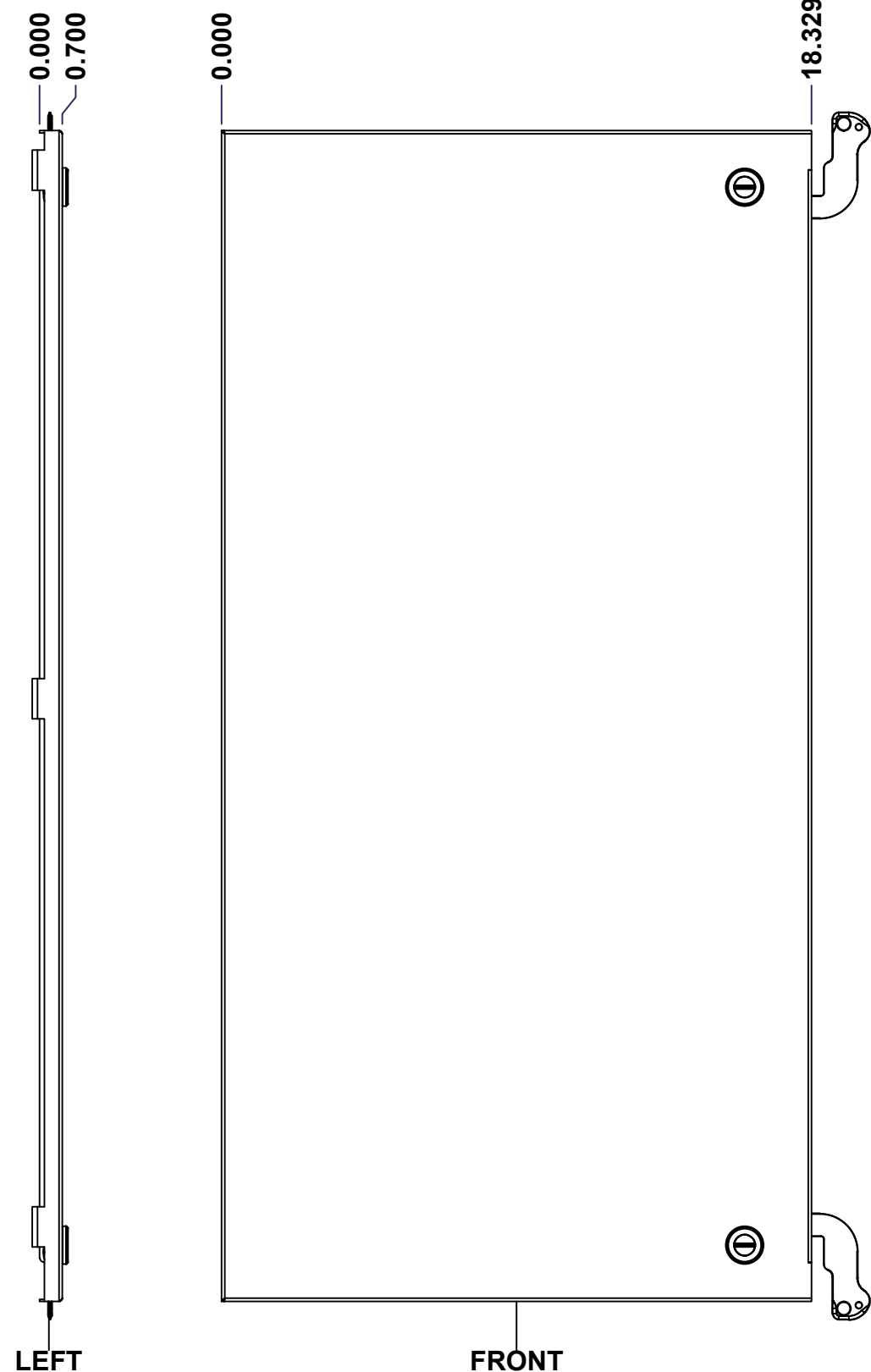
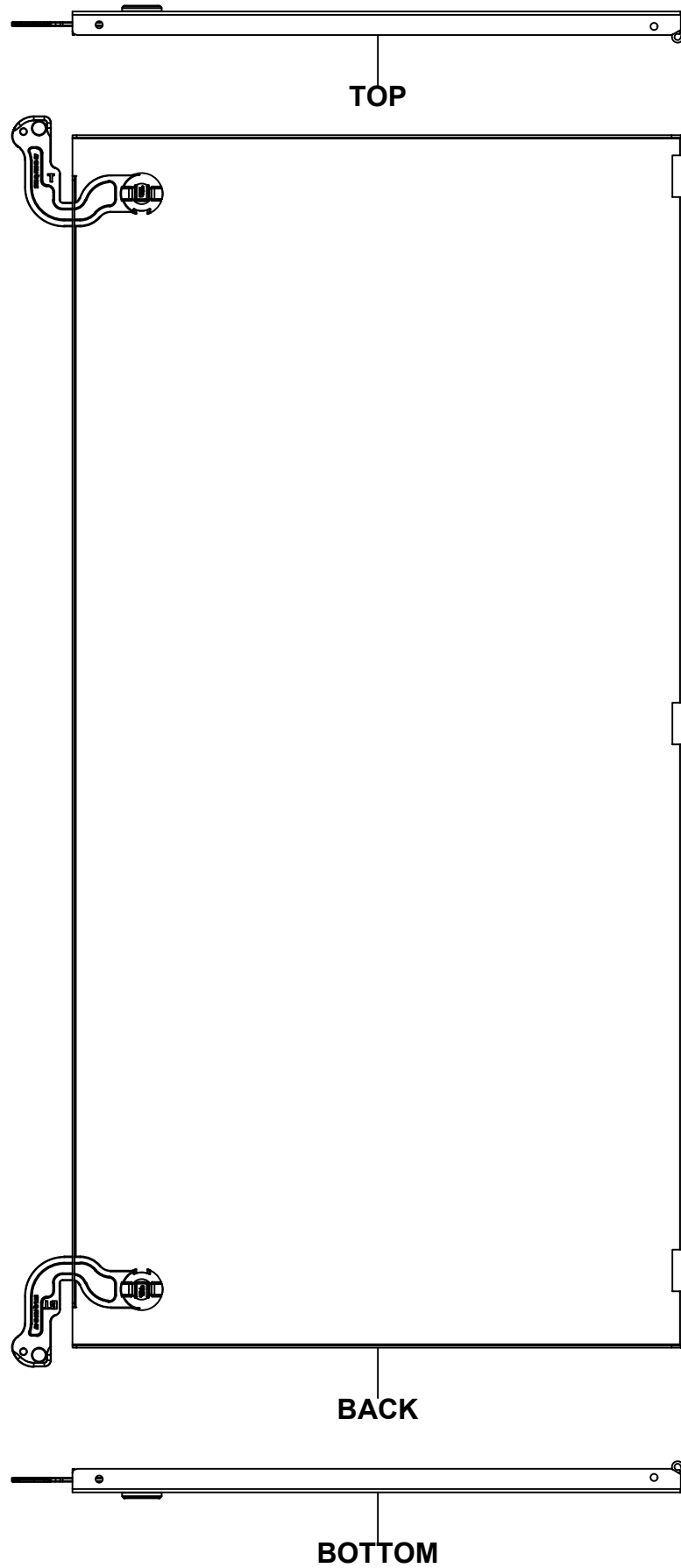

**APPROVED FOR PRODUCTION  
APPROUVÉ POUR PRODUCTION**

SIGNATURE: \_\_\_\_\_  
 NAME / NOM: \_\_\_\_\_  
 DATE: \_\_\_\_\_

Please visit: [www.boxcadexm.com](http://www.boxcadexm.com)

**SEE BILL OF MATERIAL ON LAST PAGE**

No.	Revisions	Date	By/Par

**Isometric View**

Tél: (450) 979-4373 Fax: (450) 979-4626 <a href="http://www.exmweb.com">www.exmweb.com</a>		Flatness Aplatissement
		Max 3.0mm
Customer Client		Date
Drawn By / Dessiné Par: BoxCad: patsan		Date: 30-Nov-22
Material / Matière: 14 Ga Cold Rolled A1008 CS Type B (1.7mm)		
Color / Couleur: Asa-61 Grey	Finish / Fini: Smooth	
Description: 1100MCDD 36" x 36" Cover		Detail Rev.
Part Number / Numéro Pièce: <b>1100MCDD363612LD</b>	Rev. <b>0</b>	6 / 11

This drawing is confidential and must not be reproduced or used without the consent of EXM

Ce dessin est confidentiel et ne doit pas être reproduit ou utilisé sans le consentement de EXM

**APPROVED FOR PRODUCTION**  
**APPROUVÉ POUR PRODUCTION**  
 SIGNATURE: \_\_\_\_\_  
 NAME / NOM: \_\_\_\_\_  
 DATE: \_\_\_\_\_  
 Please visit: [www.boxcadexm.com](http://www.boxcadexm.com)

No.	Revisions	Date	By/Par

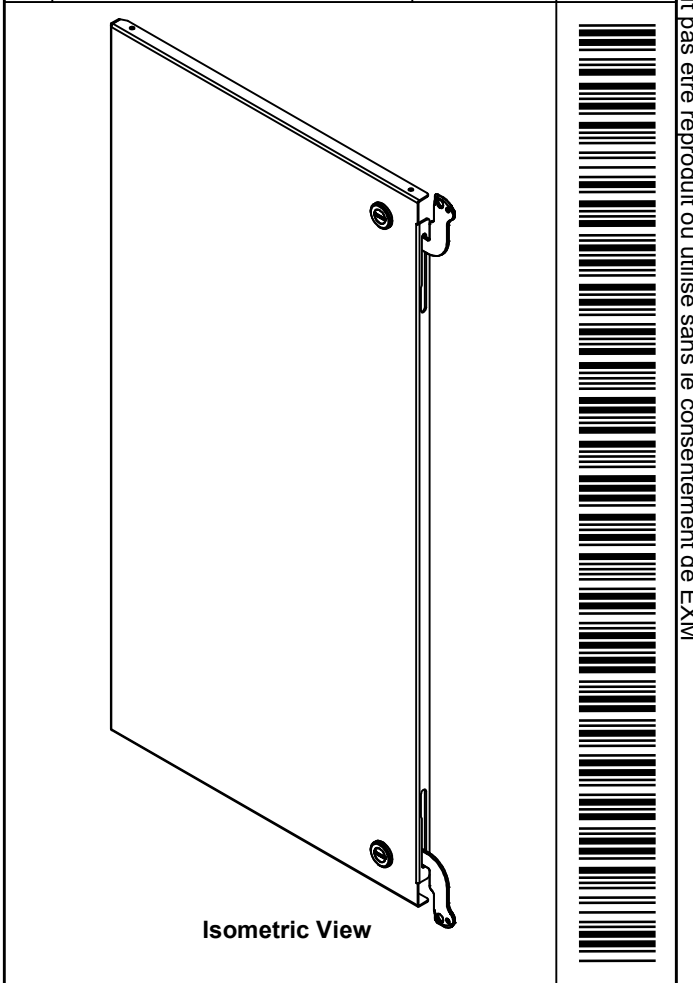

 Tél: (450) 979-4373 Fax: (450) 979-4626 <a href="http://www.exmweb.com">www.exmweb.com</a>		Flatness Aplatissement Max 3.0mm Projection 
Customer Client	Date	
Drawn By Dessiné Par	BoxCad: patsan	Date 30-Nov-22
Material Matière	14 Ga Cold Rolled A1008 CS Type B (1.7mm)	
Color Couleur	Asa-61 Grey	Finish Fini Smooth
Description		Detail Rev.
1100MCDD 36" x 36" Cover		
Part Number Numéro Pièce	Rev.	7
<b>1100MCDD363612LD</b>	<b>0</b>	11

QTY	Part Number	Rev	Description
1	STK-P-02400S	0	Powder Paint (Asa-61 Grey / Smooth)
1	STK-Q-78642	7	1100 MC - Lower Closing Cam
1	STK-Q-78643	7	1100 MC - Upper Closing Cam
2	STK-Q-78631	2	1100 SS 1/4 Turn Lock - Insert
1	1100MCDD363612LD-P	0	1100MCDD 36" x 36" x 12" Lock Cover Part
Parts List			

This drawing is confidential and must not be reproduced or used without the consent of EXM

Ce dessin est confidentiel et ne doit pas être reproduit ou utilisé sans le consentement de EXM

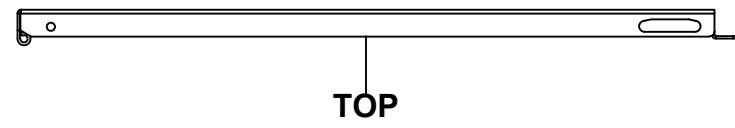

TOP

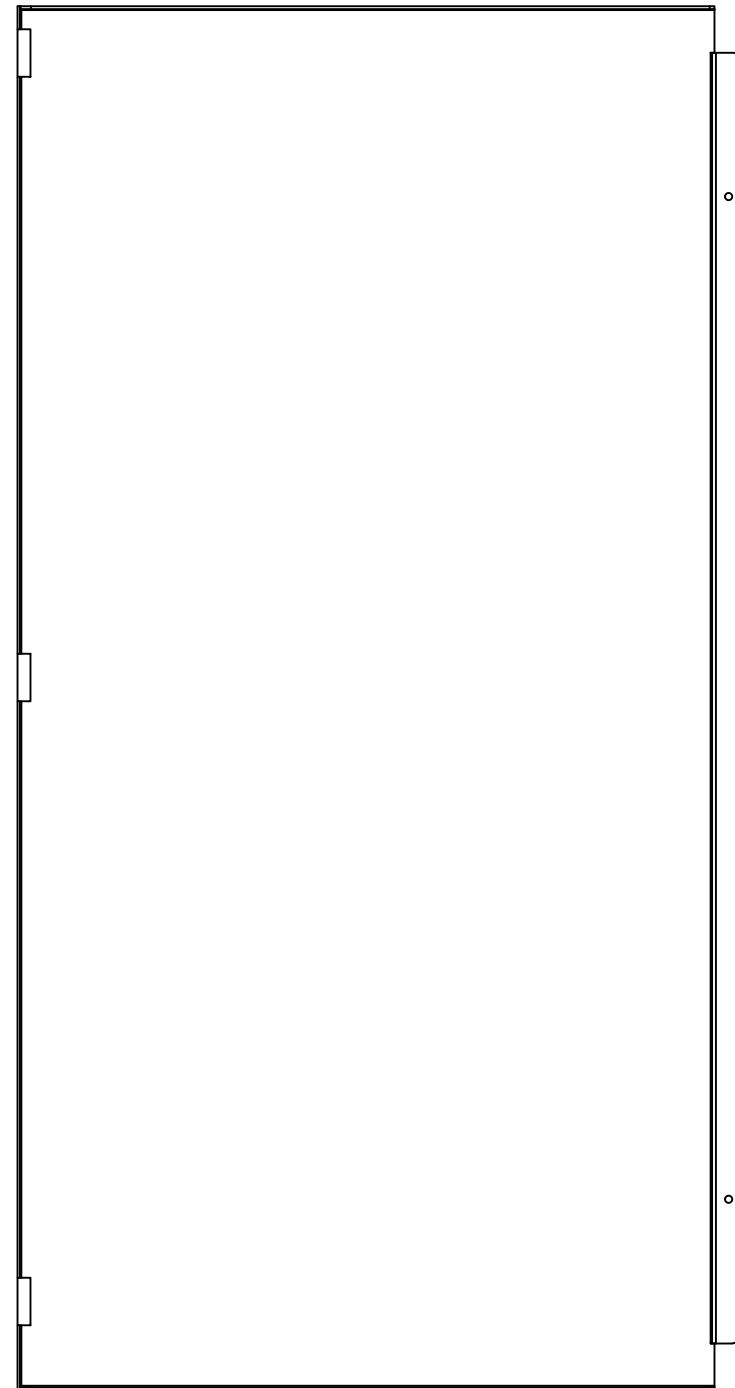

BACK

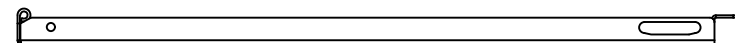

BOTTOM

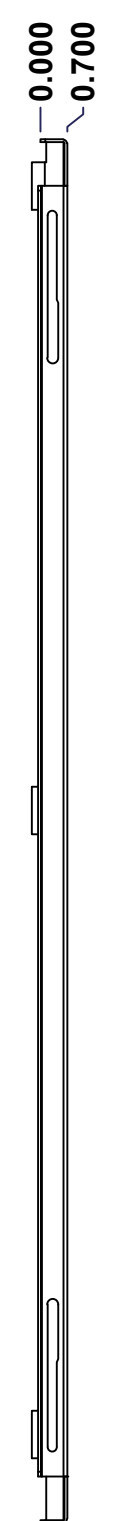

LEFT

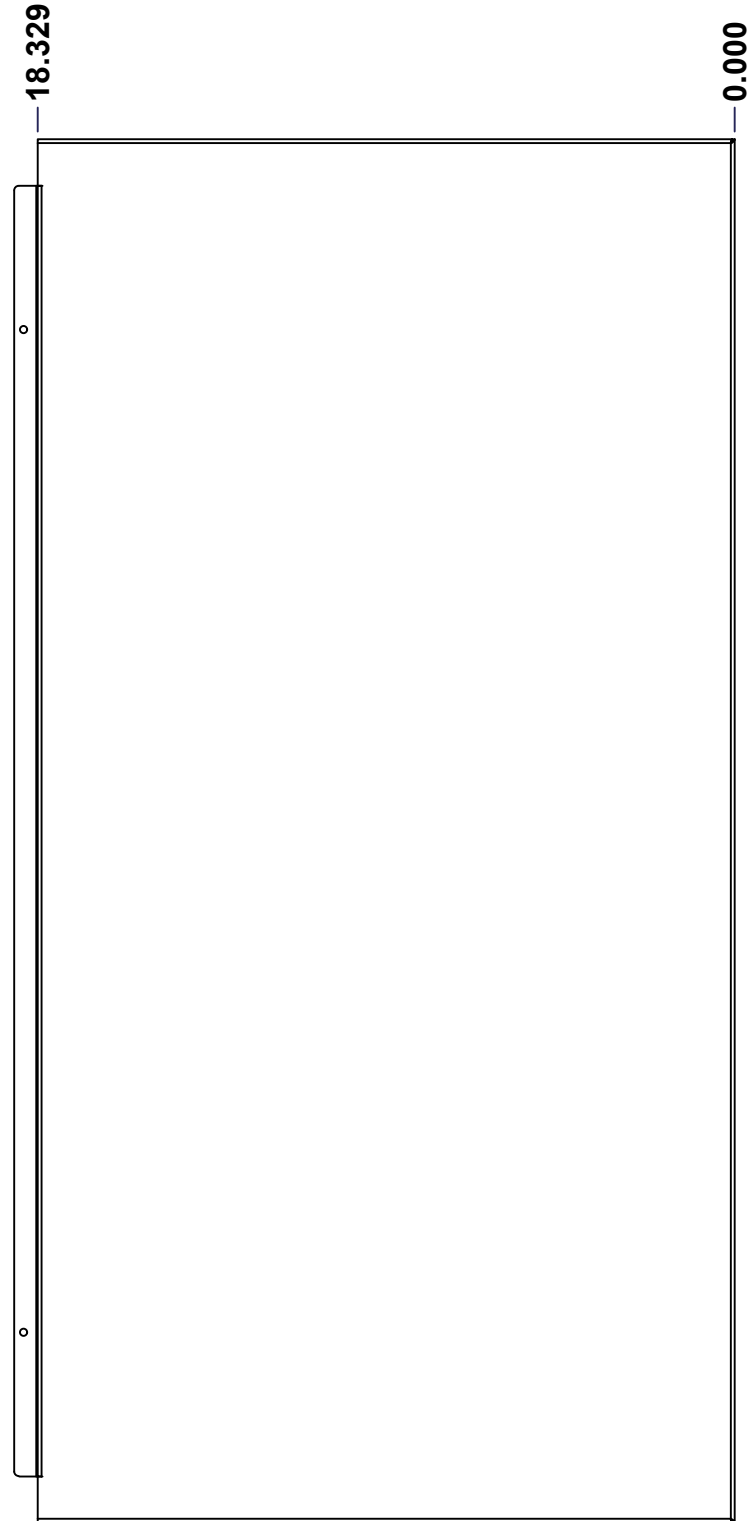

FRONT

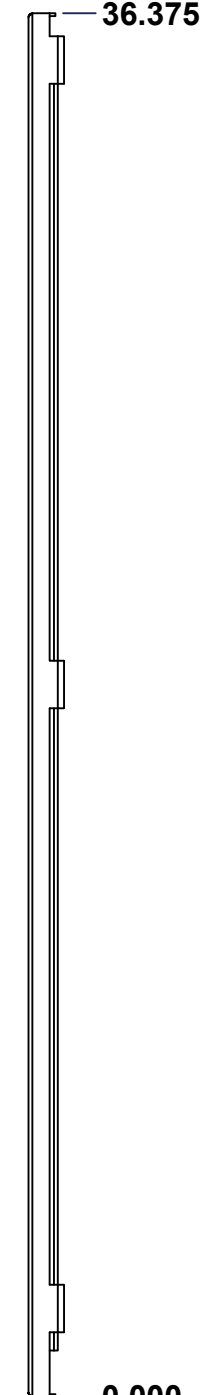

RIGHT

**APPROVED FOR PRODUCTION**  
**APPROUVÉ POUR PRODUCTION**  
 SIGNATURE: \_\_\_\_\_  
 NAME / NOM: \_\_\_\_\_  
 DATE: \_\_\_\_\_  
 Please visit: [www.boxcadexm.com](http://www.boxcadexm.com)

No.	Revisions	Date	By/Par

Isometric View

Tél: (450) 979-4373 Fax: (450) 979-4626 <a href="http://www.exmweb.com">www.exmweb.com</a>		Flatness Aplatissement	
		Max 3.0mm	
Customer Client		Date	
Drawn By Dessiné Par		Date	
Material Matière		Projection	
14 Ga Cold Rolled A1008 CS Type B (1.7mm)			
Color Couleur		Finish Fini	
Asa-61 Grey		Smooth	
Description			Detail Rev.
1100MCDD 36" x 36" Cover			
Part Number Numéro Pièce		Rev.	8
1100MCDD363612FD		0	11

SEE BILL OF MATERIAL ON LAST PAGE

This drawing is confidential and must not be reproduced or used without the consent of EXM

Ce dessin est confidentiel et ne doit pas être reproduit ou utilisé sans le consentement de EXM

**APPROVED FOR PRODUCTION**  
**APPROUVÉ POUR PRODUCTION**  
 SIGNATURE: \_\_\_\_\_  
 NAME / NOM: \_\_\_\_\_  
 DATE: \_\_\_\_\_  
 Please visit: [www.boxcadexm.com](http://www.boxcadexm.com)

No.	Revisions	Date	By/Par

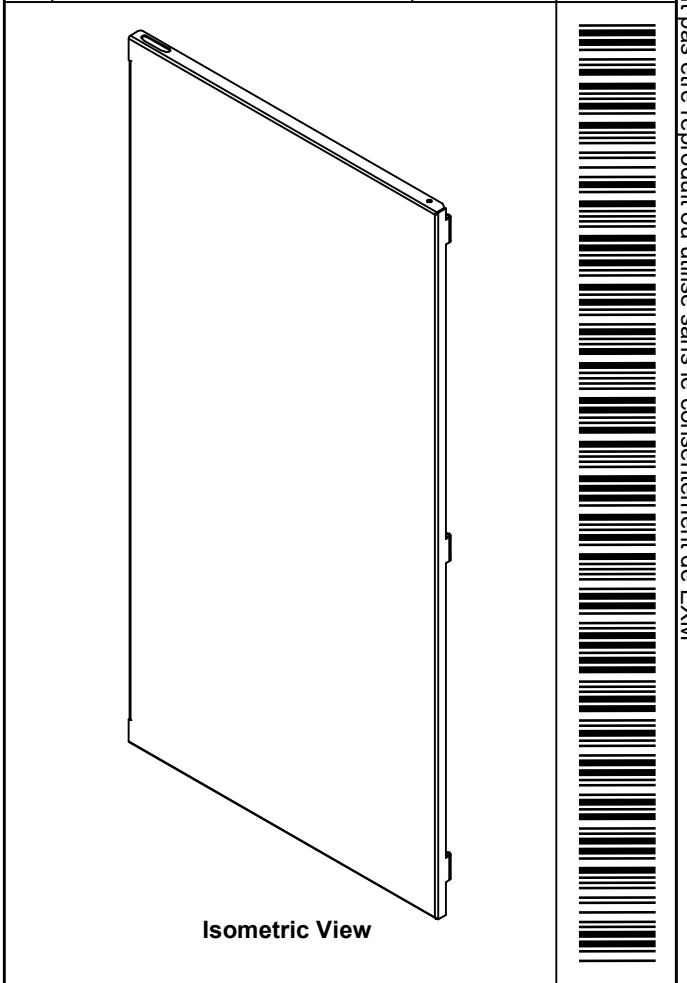

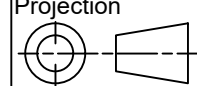
 Tél: (450) 979-4373 Fax: (450) 979-4626 <a href="http://www.exmweb.com">www.exmweb.com</a>		Flatness Aplatissement Max 3.0mm Projection 
Customer Client	Date	
Drawn By / Dessiné Par: BoxCad: patsan	Date: 30-Nov-22	
Material / Matière: 14 Ga Cold Rolled A1008 CS Type B (1.7mm)		
Color / Couleur: Asa-61 Grey	Finish / Fini: Smooth	
Description: 1100MCDD 36" x 36" Cover		Detail Rev.
Part Number / Numéro Pièce: <b>1100MCDD363612FD</b>	Rev.:	9
		11

QTY	Part Number	Rev	Description
1	STK-P-02400S	0	Powder Paint (Asa-61 Grey / Smooth)
1	1100MCDD363612FD-P	0	1100MCDD 36" x 36" x 12" Flange Cover Part
Parts List			

This drawing is confidential and must not be reproduced or used without the consent of EXM

Ce dessin est confidentiel et ne doit pas être reproduit ou utilisé sans le consentement de EXM

**APPROVED FOR PRODUCTION**  
**APPROUVÉ POUR PRODUCTION**  
 SIGNATURE: \_\_\_\_\_  
 NAME / NOM: \_\_\_\_\_  
 DATE: \_\_\_\_\_  
 Please visit: [www.boxcadexm.com](http://www.boxcadexm.com)

No.	Revisions	Date	By/Par

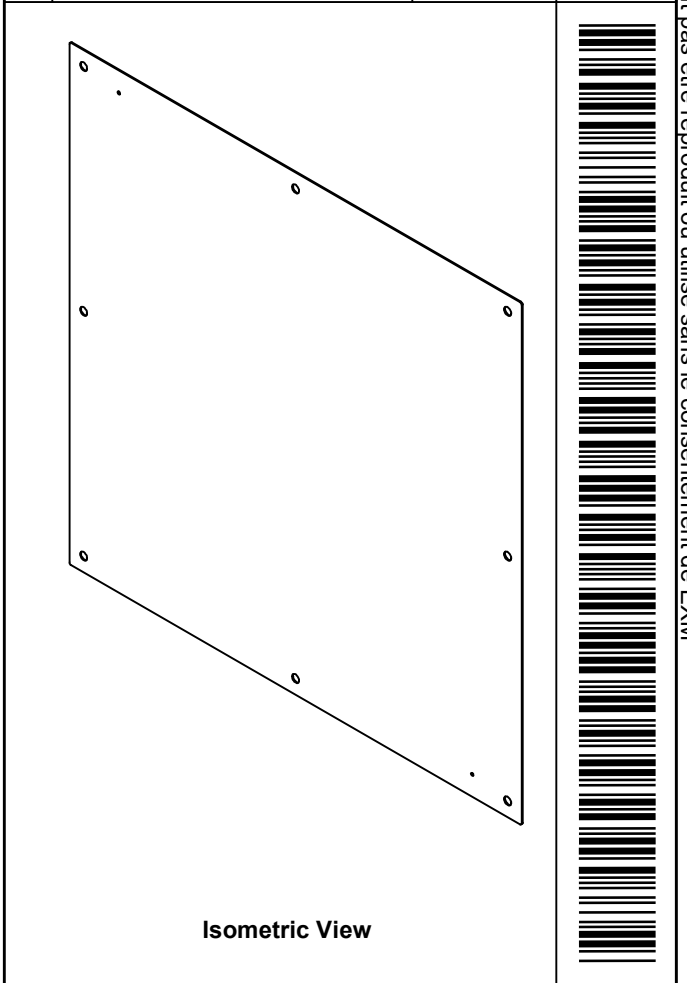
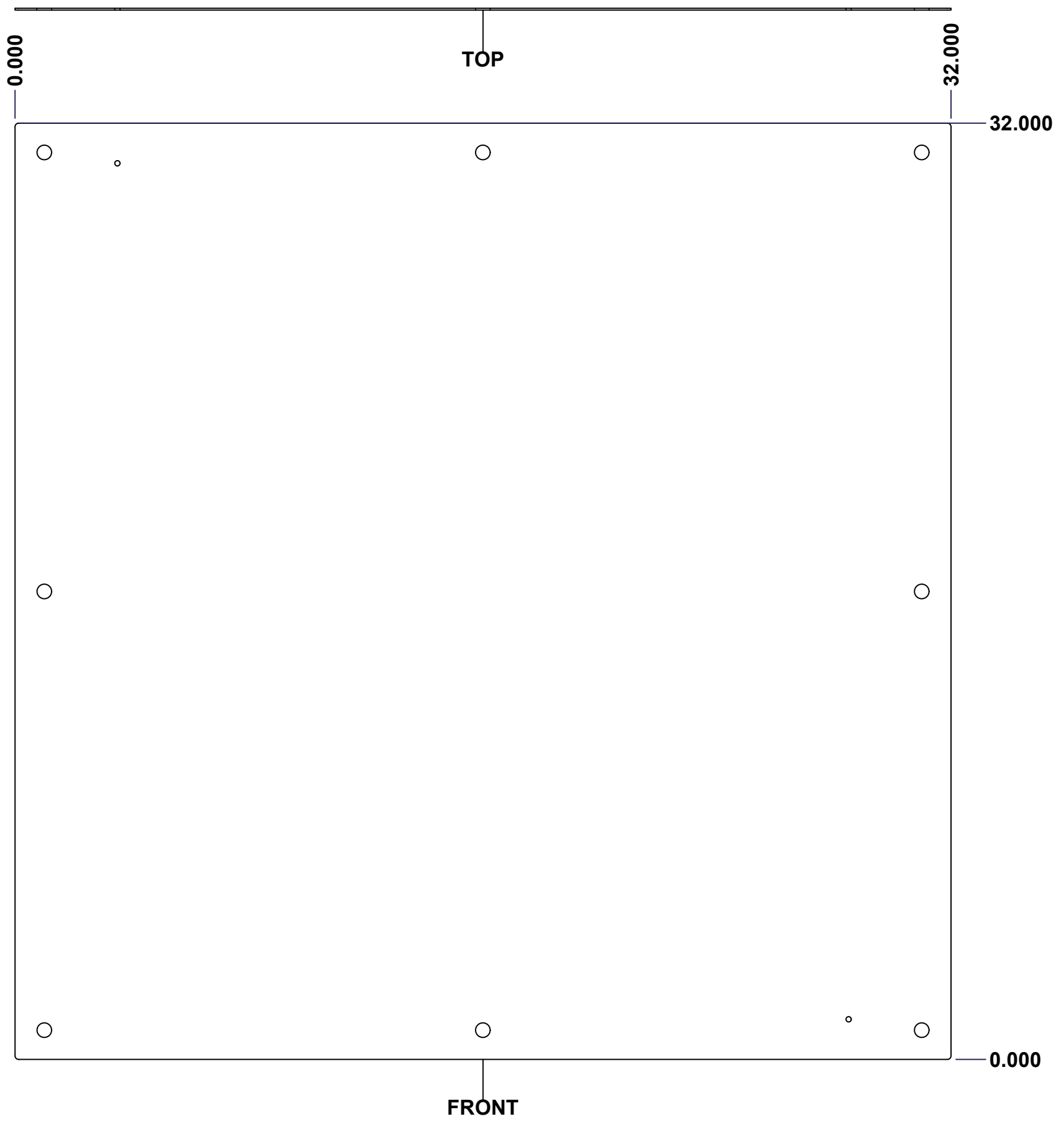

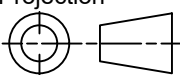
 Tél: (450) 979-4373 Fax: (450) 979-4626 <a href="http://www.exmweb.com">www.exmweb.com</a>		Flatness Aplatissement Max 3.0mm Projection 
Customer Client	Date	
Drawn By Dessiné Par	BoxCad: patsan	Date 30-Nov-22
Material Matière	14 Ga Cold Rolled A1008 CS Type B (1.7mm)	
Color Couleur	Asa-61 Grey	Finish Fini Smooth
Description 1100MCDD 36" x 36" Inner Panel		Detail Rev.
Part Number Numéro Pièce	Rev. 0	10 11

**SEE BILL OF MATERIAL ON LAST PAGE**

This drawing is confidential and must not be reproduced or used without the consent of EXM

Ce dessin est confidentiel et ne doit pas être reproduit ou utilisé sans le consentement de EXM

**APPROVED FOR PRODUCTION**  
**APPROUVÉ POUR PRODUCTION**  
 SIGNATURE: \_\_\_\_\_  
 NAME / NOM: \_\_\_\_\_  
 DATE: \_\_\_\_\_  
 Please visit: [www.boxcadexm.com](http://www.boxcadexm.com)

No.	Revisions	Date	By/Par

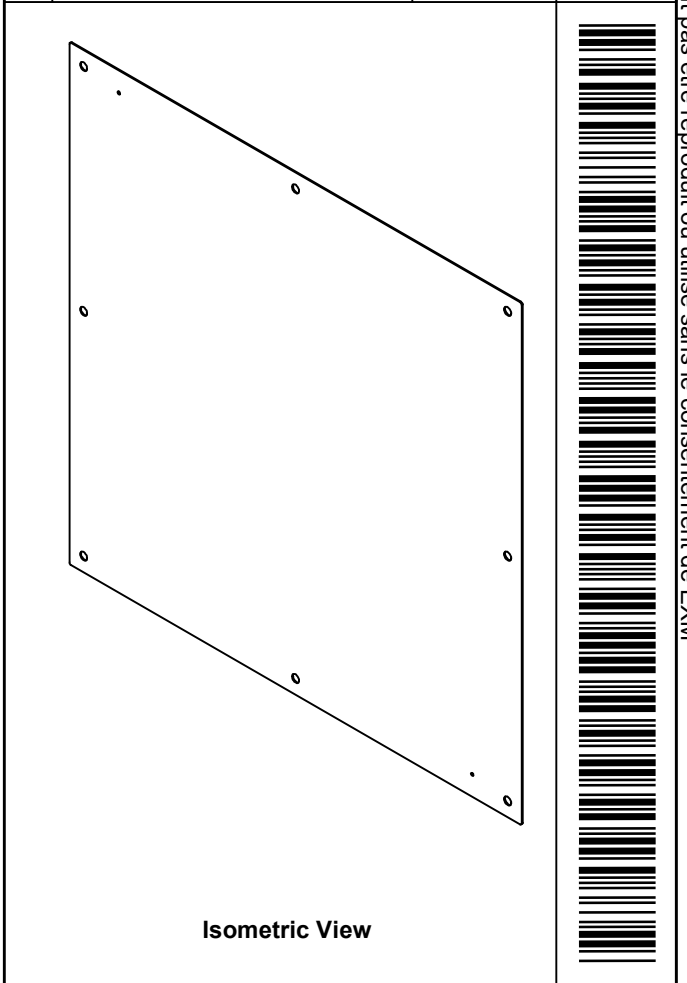

Isometric View

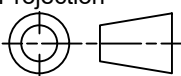
 Tél: (450) 979-4373 Fax: (450) 979-4626 <a href="http://www.exmweb.com">www.exmweb.com</a>		Flatness Aplatissement Max 3.0mm
Projection 		Date
Customer Client	BoxCad: patsan	Date 30-Nov-22
Material Matière	14 Ga Cold Rolled A1008 CS Type B (1.7mm)	
Color Couleur	Asa-61 Grey	Finish Fini Smooth
Description	1100MCDD 36" x 36" Inner Panel	
Part Number Numéro Pièce	<b>1100MCDD363612IP</b>	Detail Rev. 11
		0

Qty	Part Number	Rev	Description
1	STK-P-02400S	0	Powder Paint (Asa-61 Grey / Smooth)
1	1100MCDD363612IP-P	0	1100MCDD 36" x 36" Inner Panel Part
Parts List			