

This drawing is confidential and must not be reproduced or used without the consent of EXM

Ce dessin est confidentiel et ne doit pas être reproduit ou utilisé sans le consentement de EXM

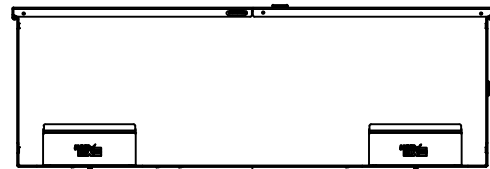

TOP

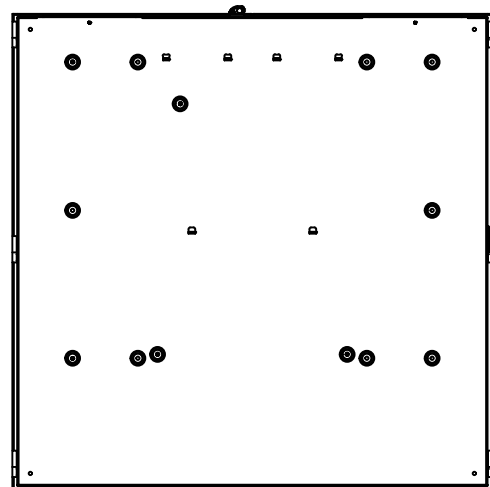

BACK

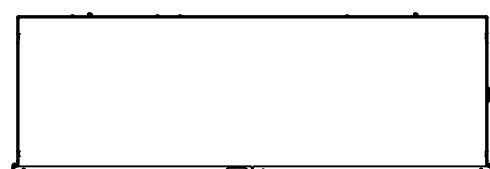

BOTTOM

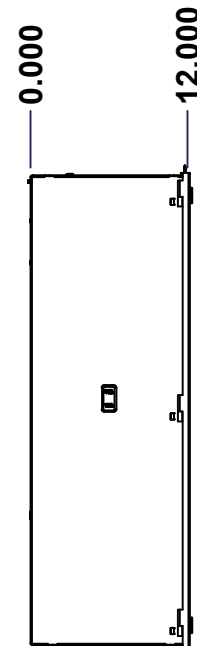

LEFT

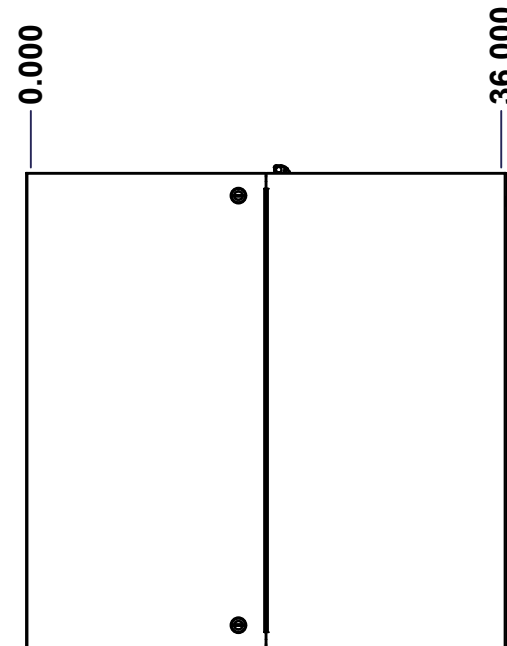

FRONT

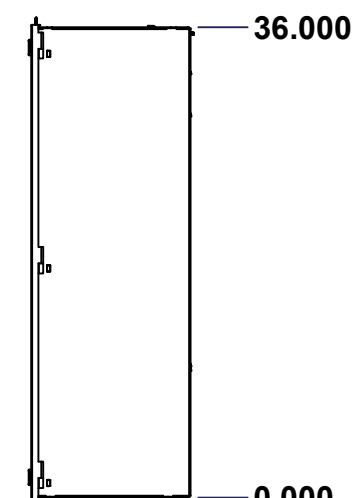

RIGHT

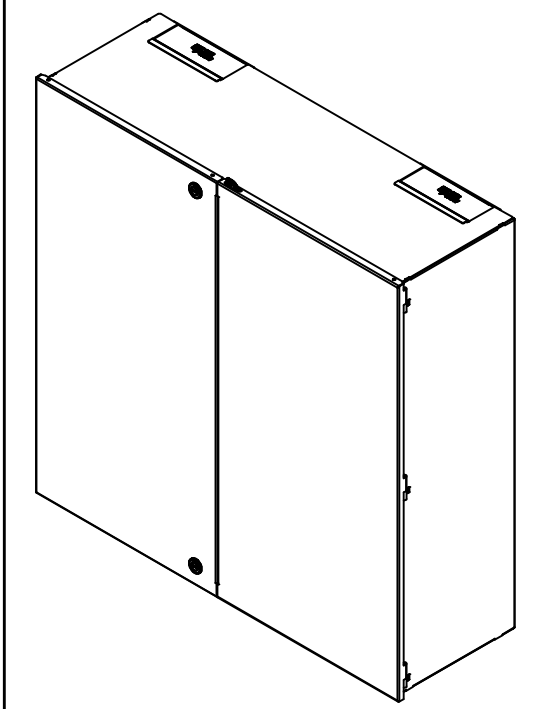

Isometric View

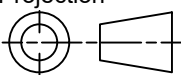

No.	Revisions	Date	By/Par

 Tél: (450) 979-4373 Fax: (450) 979-4626 www.exmweb.com		Flatness Aplatissement Max 3.0mm Projection 
Customer Client	Date	
Drawn By Dessiné Par	BoxCad: BoxCad	Date 27-Nov-24
Material Matière	14 Ga Cold Rolled A1008 CS Type B (1.7mm)	
Color Couleur	Asa-61 Grey	Finish Fini Smooth
Description	Detail Rev.	
1100MCHQDD 36" x 36" x 12" Assembly		
Part Number Numéro Pièce	Rev.	1
1100MCHQDD363612	0	10

SEE BILL OF MATERIAL ON LAST PAGE

This drawing is confidential and must not be reproduced or used without the consent of EXM

Ce dessin est confidentiel et ne doit pas être reproduit ou utilisé sans le consentement de EXM

NOTE	
ITEM	DESCRIPTION
1	NEMA 1 Enclosure (IP20)
2	C/W Inner panel (Included)

No.	Revisions	Date	By/Par

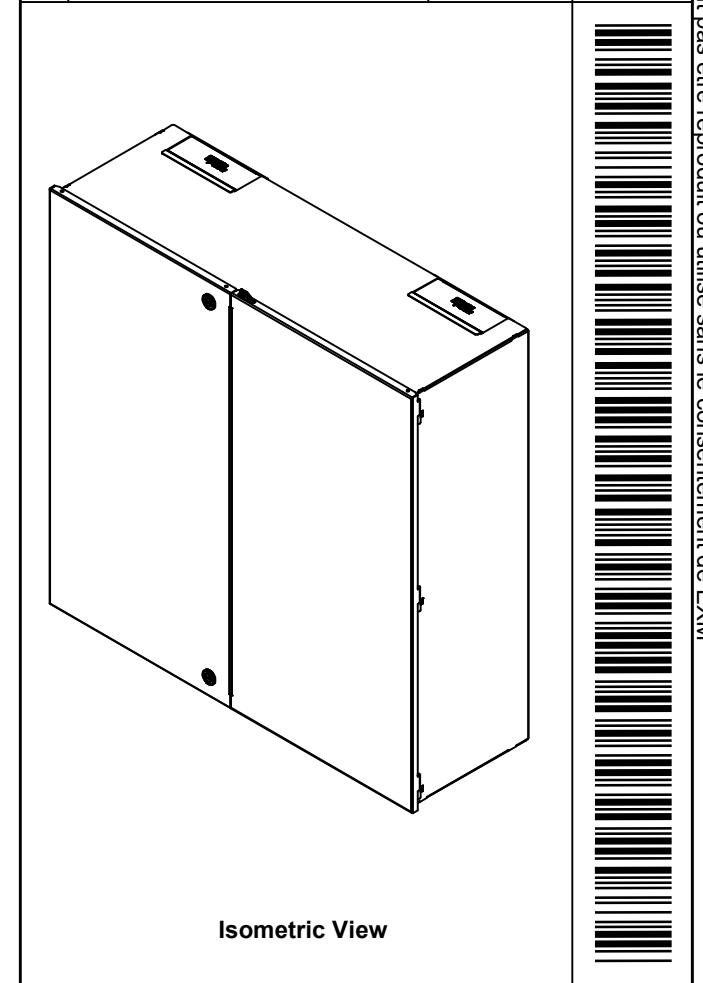

EXM
www.exm.com

Tél: (450) 979-4373
Fax: (450) 979-4626
www.exmweb.com

Flatness
Aplatissement
Max 3.0mm

Projection

Customer Client	Date
Drawn By Dessiné Par	Date 27-Nov-24

Material Matière	14 Ga Cold Rolled A1008 CS Type B (1.7mm)
---------------------	---

Color Couleur	Asa-61 Grey	Finish Fini	Smooth
------------------	-------------	----------------	--------

Description	Detail Rev.
1100MCHQDD 36" x 36" x 12" Assembly	

Part Number Numéro Pièce	Rev.	2
1100MCHQDD363612	0	10

Qty	Part Number	Rev	Description
1	881SPCHQ3	0	1100MCHQ Universal support voltage panel
1	881SPCHQ2	0	1100MCHQ Universal support current panel
1	881SPCHQ1	0	1100MCHQ Accessory Plate
5	STK-Q-03210	0	Thread Cutting Screw 1/4-20 x 5/16"
2	STK-Q-05020	5	M5 x 8mm Thread Rolling Screw
2	STK-Q-79000	5	1100MC Cover Plate
1	1100MCHQDD363612FD	0	1100MCHQDD 36" x 36" Cover
1	1100MCHQDD363612LD	0	1100MCHQDD 36" x 36" Cover
1	1100MCHQDD363612B	0	1100MCHQDD 36" x 36" x 12" Body

Parts List

PACKING		
ITEM	QTY	DESCRIPTION
Cardboard sleeve	2	Top and Bottom
Plastic strap - Black	2	To Squeeze 2 cardboard sleeve together
Packaging label	3	White label with PN

This drawing is confidential and must not be reproduced or used without the consent of EXM

Ce dessin est confidentiel et ne doit pas être reproduit ou utilisé sans le consentement de EXM

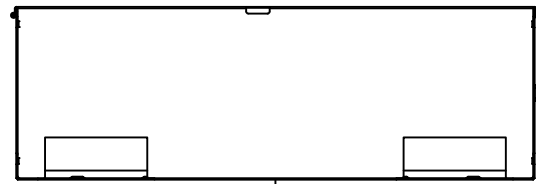

TOP

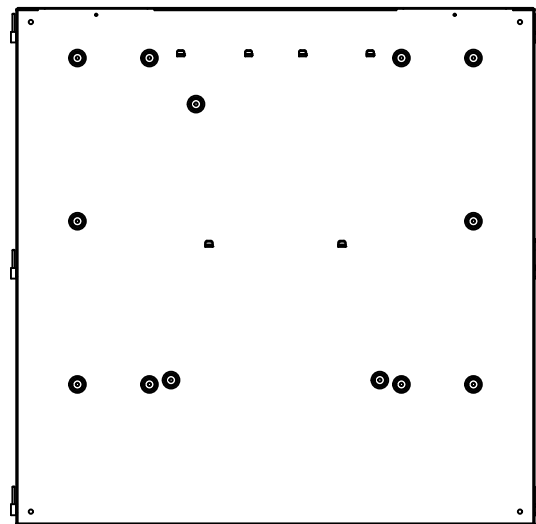

BACK

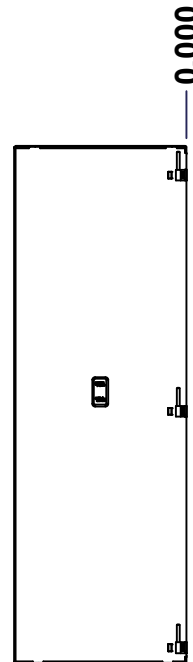

LEFT

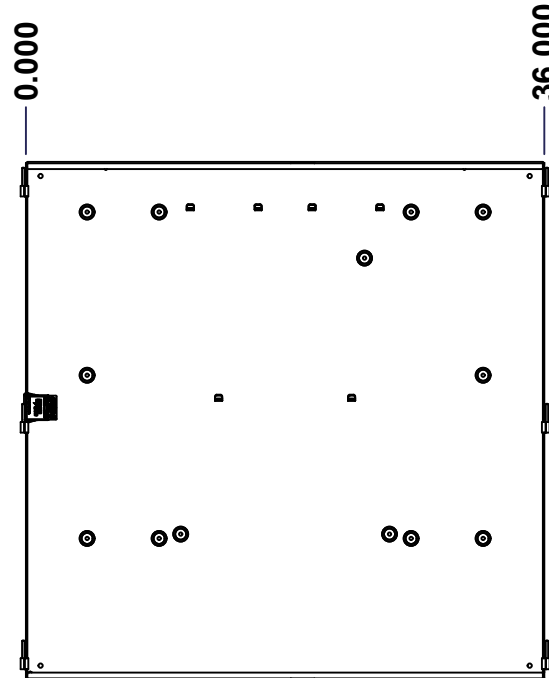

FRONT

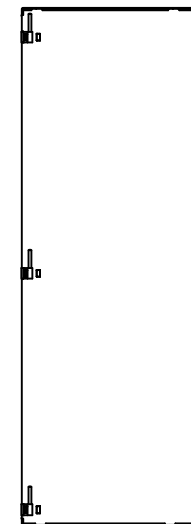

RIGHT

0.000

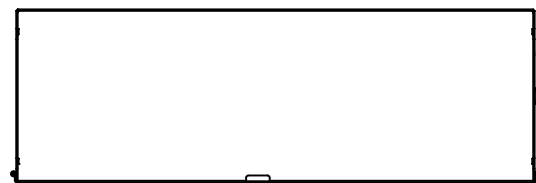

BOTTOM

No.	Revisions	Date	By/Par

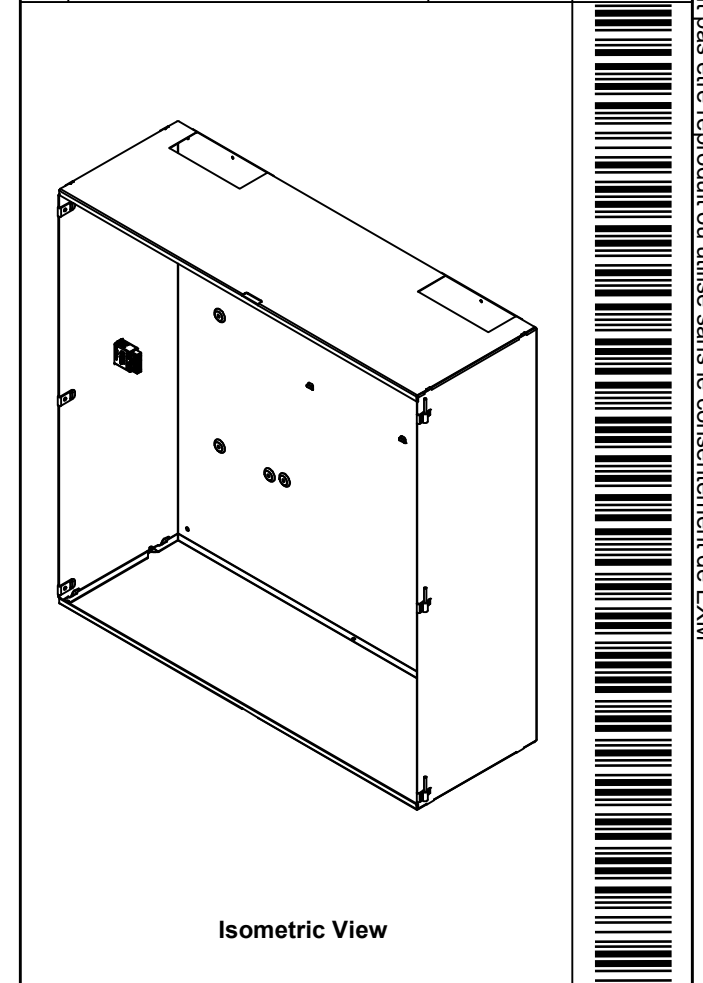

Isometric View

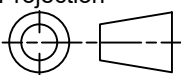

 Tél: (450) 979-4373 Fax: (450) 979-4626 www.exmweb.com		Flatness Aplatissement Max 3.0mm Projection 
Customer Client	Date	
Drawn By Dessiné Par	BoxCad: BoxCad	Date 27-Nov-24
Material Matière	14 Ga Cold Rolled A1008 CS Type B (1.7mm)	
Color Couleur	Asa-61 Grey	Finish Fini Smooth
Description	Detail Rev.	
1100MCHQDD 36" x 36" x 12" Body		
Part Number Numéro Pièce	Rev.	3
1100MCHQDD363612B	0	10

SEE BILL OF MATERIAL ON LAST PAGE

This drawing is confidential and must not be reproduced or used without the consent of EXM

Ce dessin est confidentiel et ne doit pas être reproduit ou utilisé sans le consentement de EXM

STANDARD FEATURES ARE NOT LISTED IN THIS HOLE TABLE			
HOLE TABLE - LEFT VIEW (CUSTOM FEATURE ONLY)			
CUT-OUT	XDIM	YDIM	DESCRIPTION
1	6.000	18.907	Grounding connector

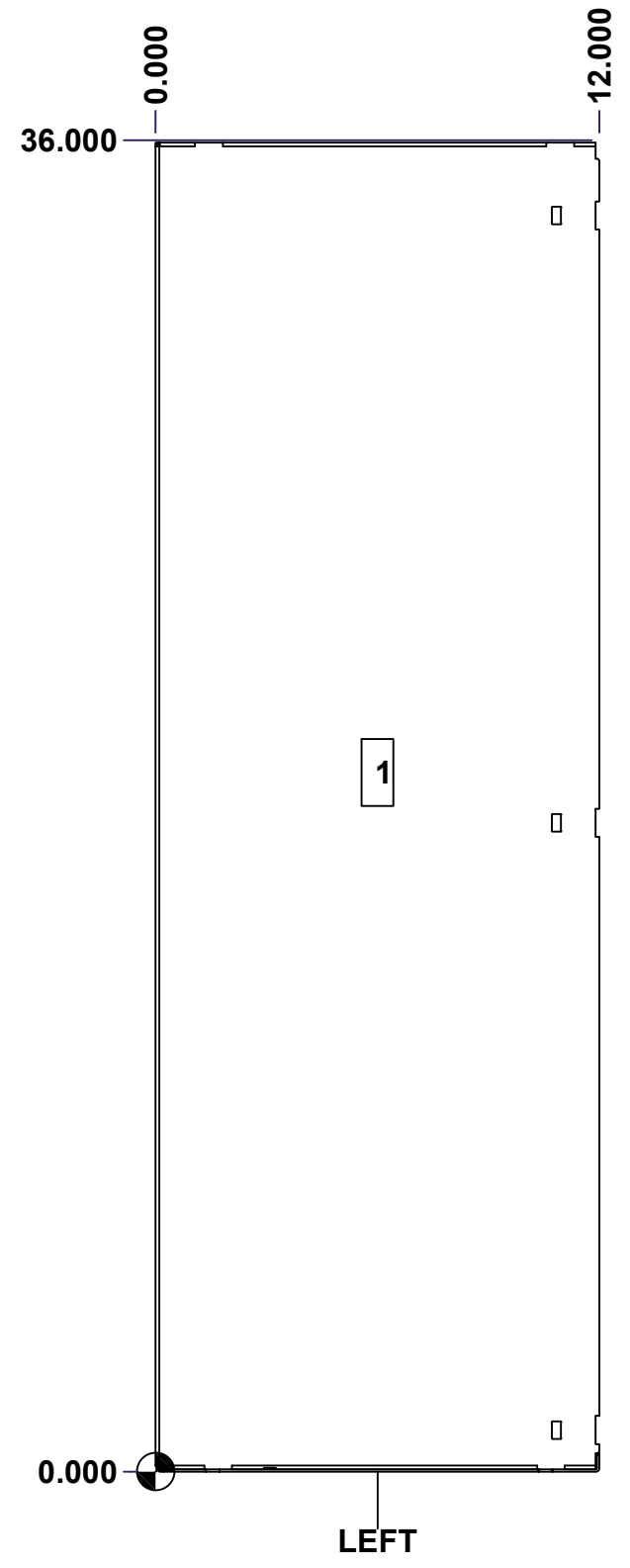

	Description	Status	
	1100MCHQDD 36" x 36" x 12" Body	(NULL)	
	Part Number Numéro Pièce	Rev.	4
	1100MCHQDD363612B	0	10

This drawing is confidential and must not be reproduced or used without the consent of EXM

Ce dessin est confidentiel et ne doit pas être reproduit ou utilisé sans le consentement de EXM

STANDARD FEATURES ARE NOT LISTED IN THIS HOLE TABLE			
HOLE TABLE - BACK VIEW (CUSTOM FEATURE ONLY)			
CUT-OUT	XDIM	YDIM	DESCRIPTION
1	4.248	32.500	Emboss punching
2	4.248	9.815	Emboss punching
3	4.248	21.157	Emboss punching
4	9.248	32.500	Emboss punching
5	9.248	9.815	Emboss punching
6	12.489	29.303	Emboss punching
7	10.748	10.138	Emboss punching
8	25.252	10.138	Emboss punching
9	26.752	32.500	Emboss punching
10	26.752	9.815	Emboss punching
11	31.752	32.500	Emboss punching
12	31.752	9.815	Emboss punching
13	31.752	21.157	Emboss punching
14	24.594	32.880	Hook punching
15	11.406	32.880	Hook punching
16	19.870	32.880	Hook punching
17	16.130	32.880	Hook punching
18	22.626	19.625	Hook punching
19	13.374	19.625	Hook punching

20	1.000	1.000	RND Ø0.290
21	1.000	35.000	RND Ø0.290
22	35.000	1.000	RND Ø0.290
23	35.000	35.000	RND Ø0.290

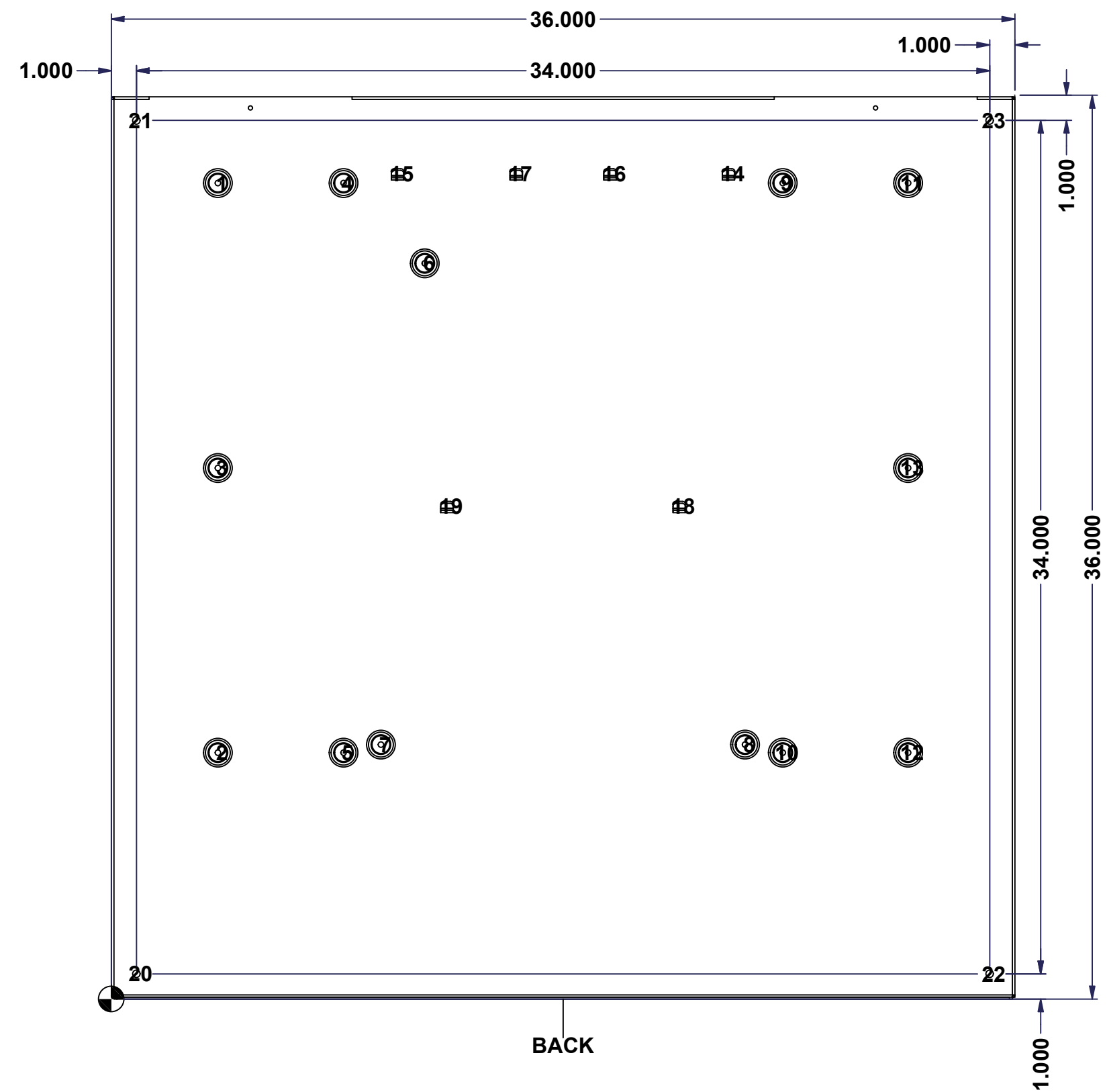

	Description	Status
	1100MCHQDD 36" x 36" x 12" Body	(NULL)
	Part Number	Rev.
	1100MCHQDD363612B	5
		0
		10

This drawing is confidential and must not be reproduced or used without the consent of EXM

Ce dessin est confidentiel et ne doit pas être reproduit ou utilisé sans le consentement de EXM

No.	Revisions	Date	By/Par

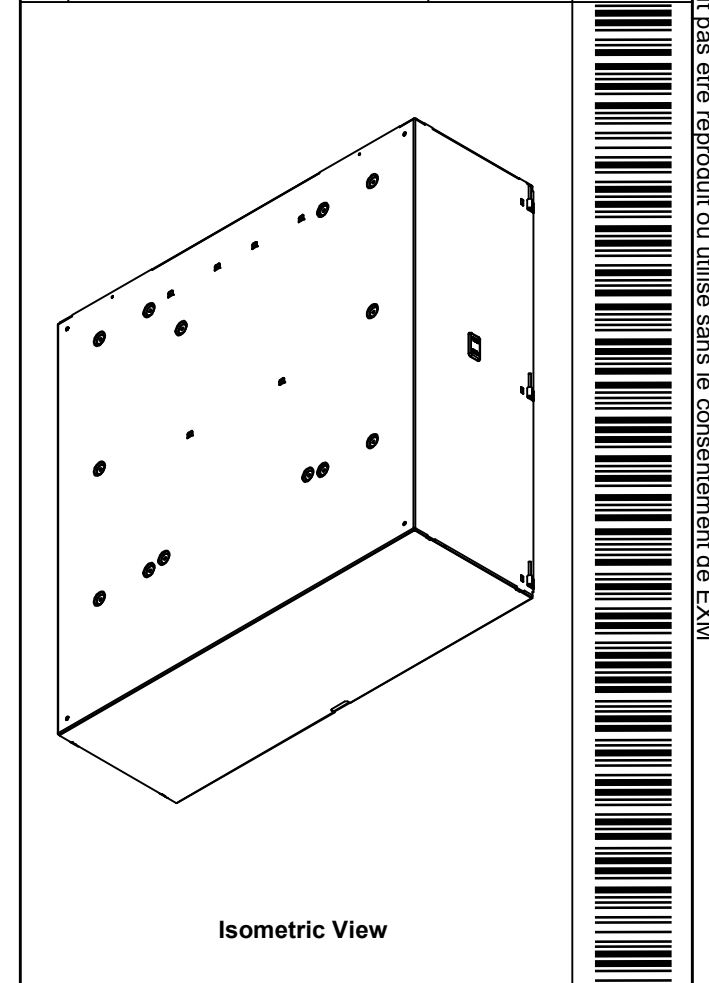

 Tél: (450) 979-4373
 Fax: (450) 979-4626
www.exmweb.com

Flatness / Aplatissement: Max 3.0mm
 Projection: 

Customer Client	Date
Drawn By / Dessiné Par: BoxCad: BoxCad	Date: 27-Nov-24
Material / Matière: 14 Ga Cold Rolled A1008 CS Type B (1.7mm)	

Color / Couleur: Asa-61 Grey	Finish / Fini: Smooth
Description: 1100MCHQDD 36" x 36" x 12" Body	Detail Rev.

Part Number / Numéro Pièce: 1100MCHQDD363612B	Rev. 0	6 / 10
--	--------	--------

Qty	Part Number	Rev	Description
1	STK-P-02400S	0	Powder Paint (Asa-61 Grey / Smooth)
1	STK-Q-55510	1	Quick Install Aluminium Connector
1	STK-Q-67225	1	Insulator Block
3	STK-A-33410	7	1100 MC Left Side Hinge Assembly
3	STK-A-33510	7	1100 MC Right Side Hinge Part
1	1100MCHQDD363612T-P	0	1100MCHQDD 36" x 36" x 12" Top Part
1	1100MCHQDD363612BT-P	0	1100MCHQDD 36" x 36" x 12" Bottom Part
1	1100MCHQDD363612B-P	0	1100MCHQDD 36" x 36" x 12" Body Part
Parts List			

This drawing is confidential and must not be reproduced or used without the consent of EXM

Ce dessin est confidentiel et ne doit pas être reproduit ou utilisé sans le consentement de EXM

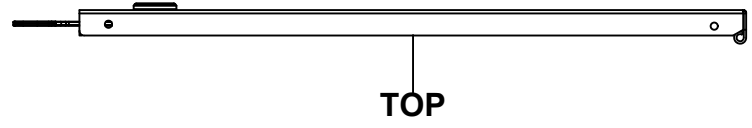

TOP

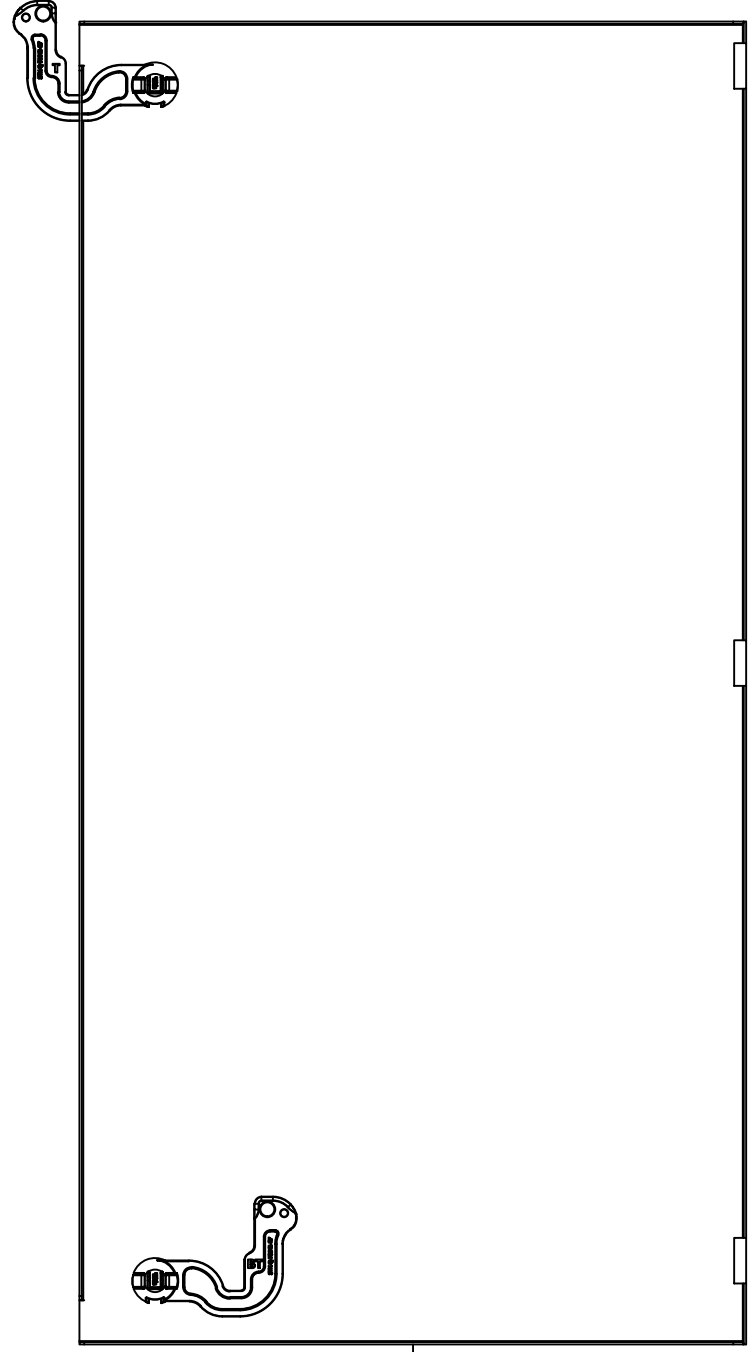

BACK

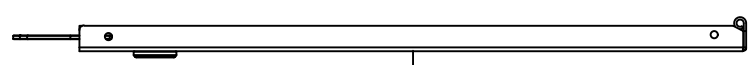

BOTTOM

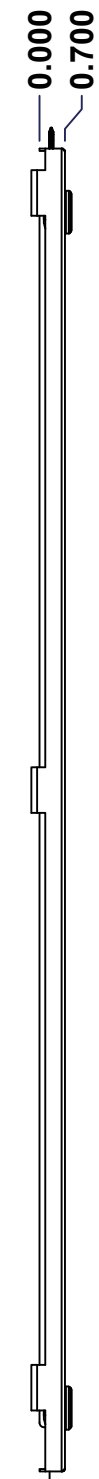

LEFT

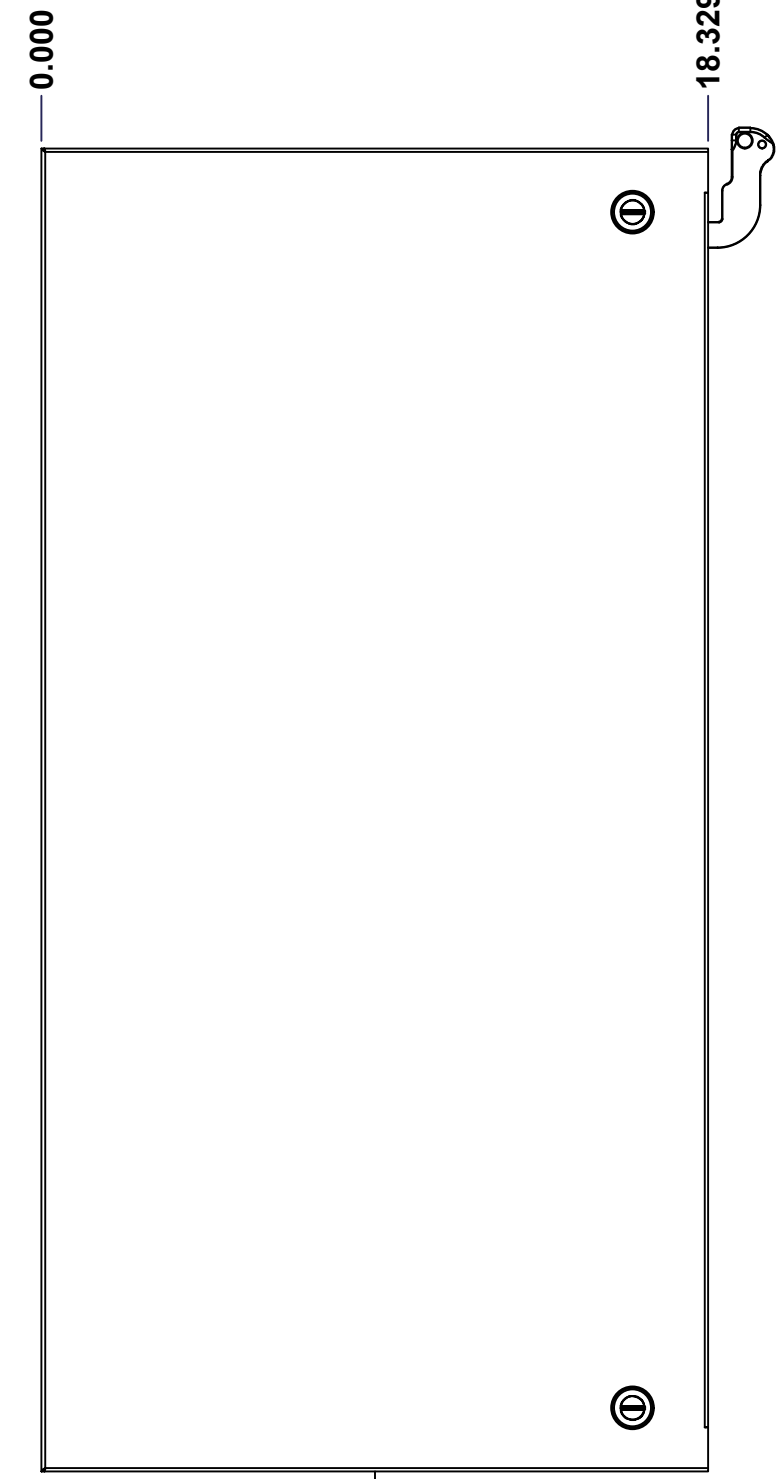

FRONT

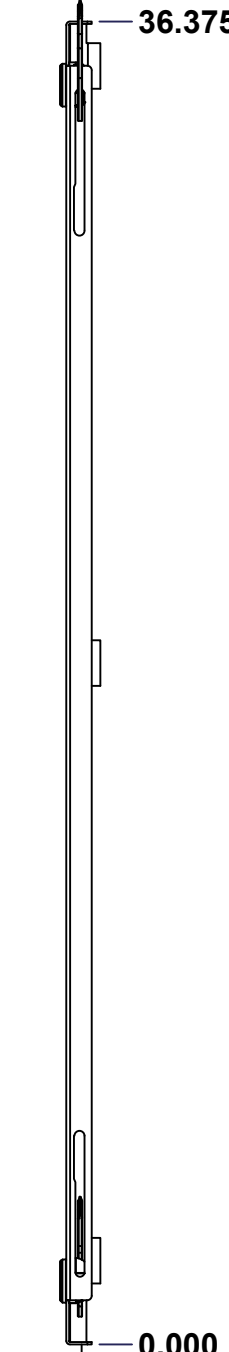

RIGHT

No.	Revisions	Date	By/Par

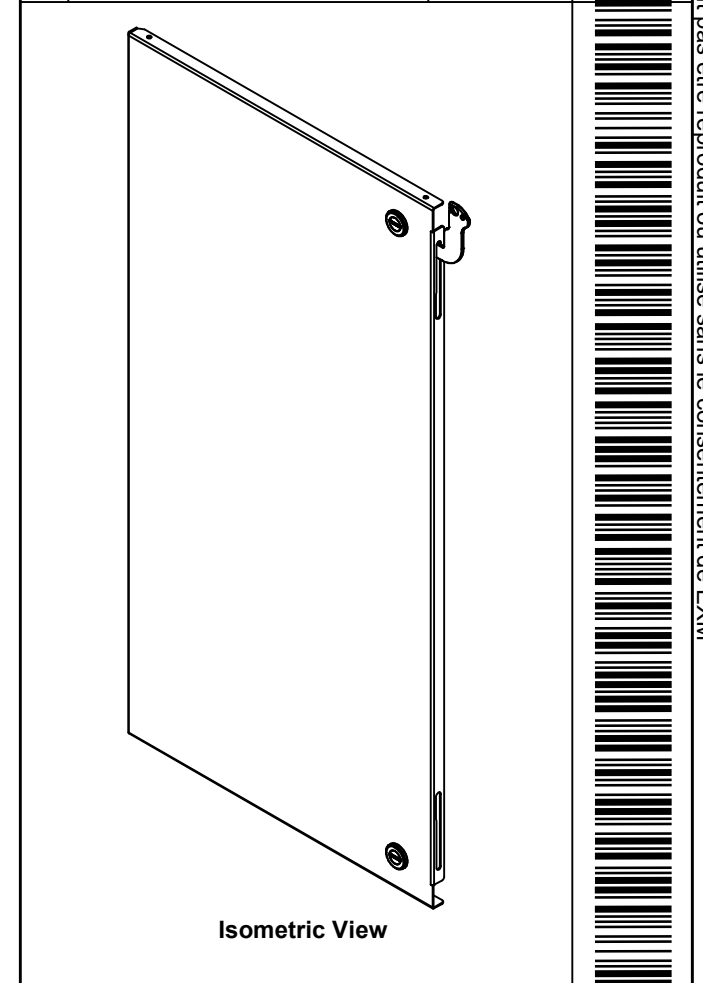

Isometric View



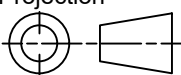

 Tél: (450) 979-4373 Fax: (450) 979-4626 www.exmweb.com		Flatness Aplatissement Max 3.0mm Projection 
Customer Client	Date	
Drawn By Dessiné Par	BoxCad: BoxCad	Date 27-Nov-24
Material Matière	14 Ga Cold Rolled A1008 CS Type B (1.7mm)	
Color Couleur	Asa-61 Grey	Finish Fini Smooth
Description	Detail Rev.	
1100MCHQDD 36" x 36" Cover		
Part Number Numéro Pièce	Rev. 0	7 / 10
SEE BILL OF MATERIAL ON LAST PAGE 1100MCHQDD363612LD		

This drawing is confidential and must not be reproduced or used without the consent of EXM

Ce dessin est confidentiel et ne doit pas être reproduit ou utilisé sans le consentement de EXM

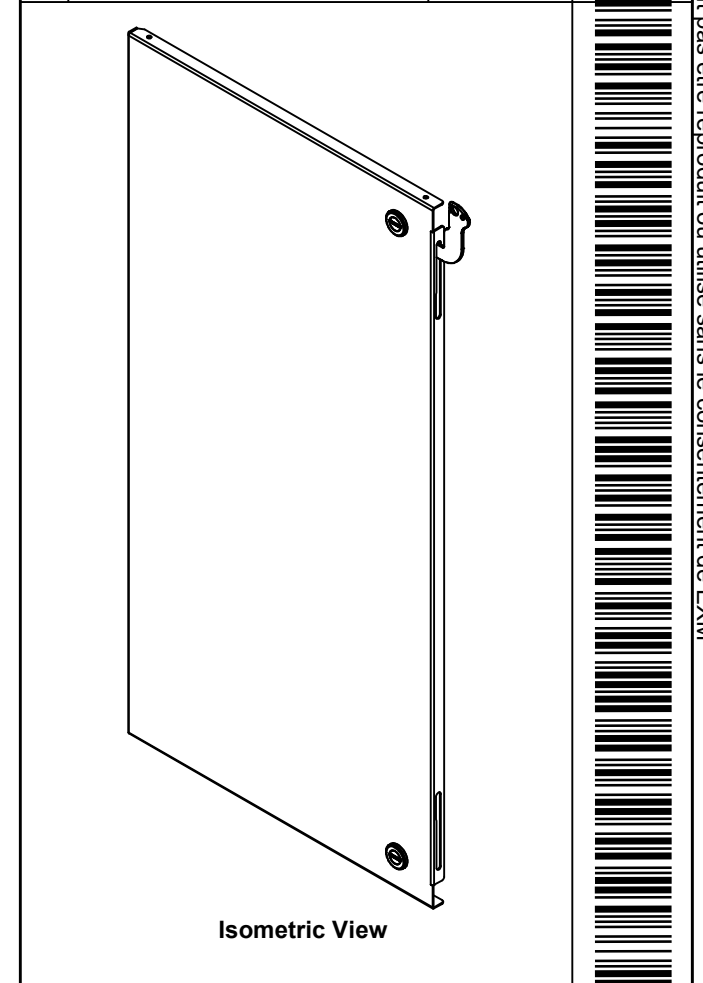
No.	Revisions	Date	By/Par

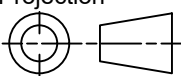

 Tél: (450) 979-4373 Fax: (450) 979-4626 www.exmweb.com		Flatness Aplatissement Max 3.0mm Projection 
Customer Client	Date	
Drawn By Dessiné Par	BoxCad: BoxCad	Date 27-Nov-24
Material Matière	14 Ga Cold Rolled A1008 CS Type B (1.7mm)	
Color Couleur	Asa-61 Grey	Finish Fini Smooth
Description		Detail Rev.
1100MCHQDD 36" x 36" Cover		
Part Number Numéro Pièce	Rev.	8
1100MCHQDD363612LD	0	10

1	STK-P-02400S	0	Powder Paint (Asa-61 Grey / Smooth)
1	STK-Q-78642	7	1100 MC - Lower Closing Cam
1	STK-Q-78643	7	1100 MC - Upper Closing Cam
2	STK-Q-78631	2	1100 SS 1/4 Turn Lock - Insert
1	1100MCHQDD363612LD-P	0	1100MCHQDD 36" x 36" x 12" Lock Cover Part
QTY	Part Number	Rev	Description
Parts List			

This drawing is confidential and must not be reproduced or used without the consent of EXM

Ce dessin est confidentiel et ne doit pas être reproduit ou utilisé sans le consentement de EXM

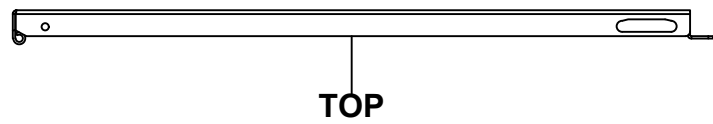

TOP

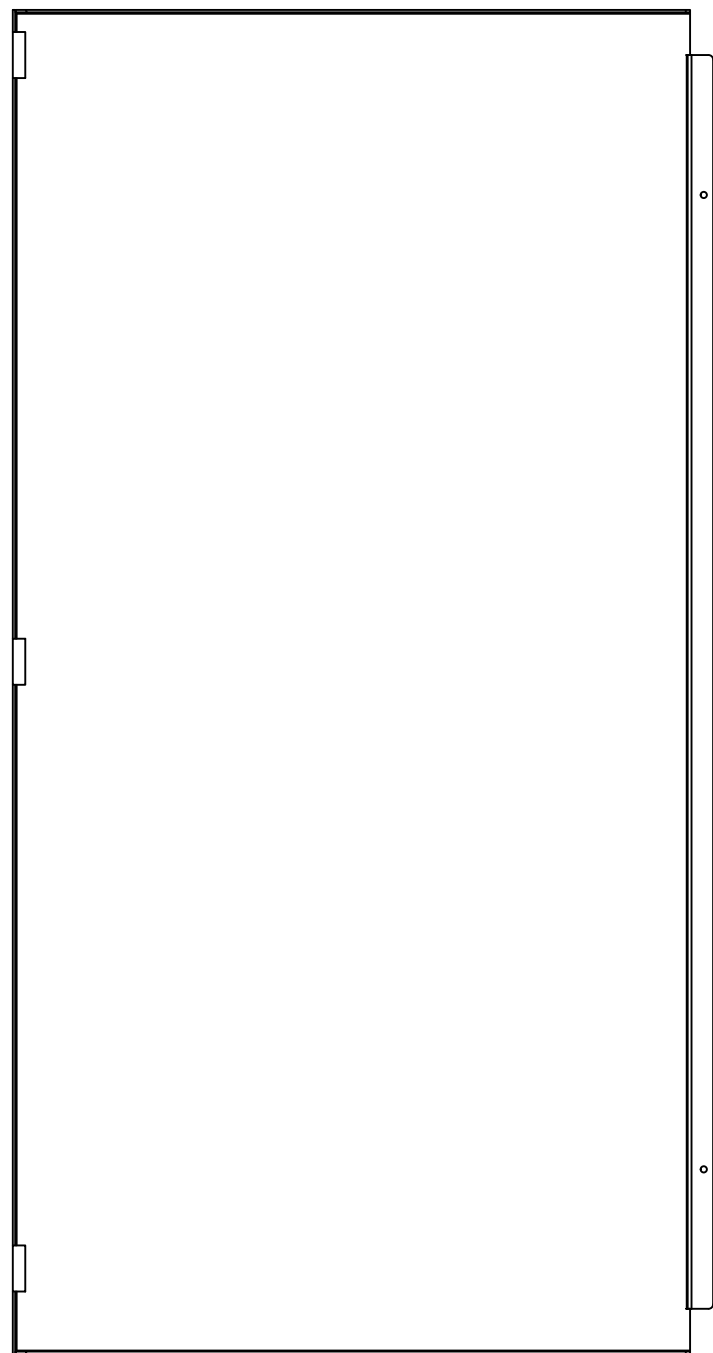

BACK

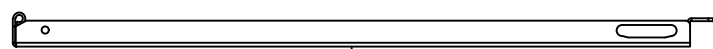

BOTTOM

0.000
0.700



LEFT

18.329

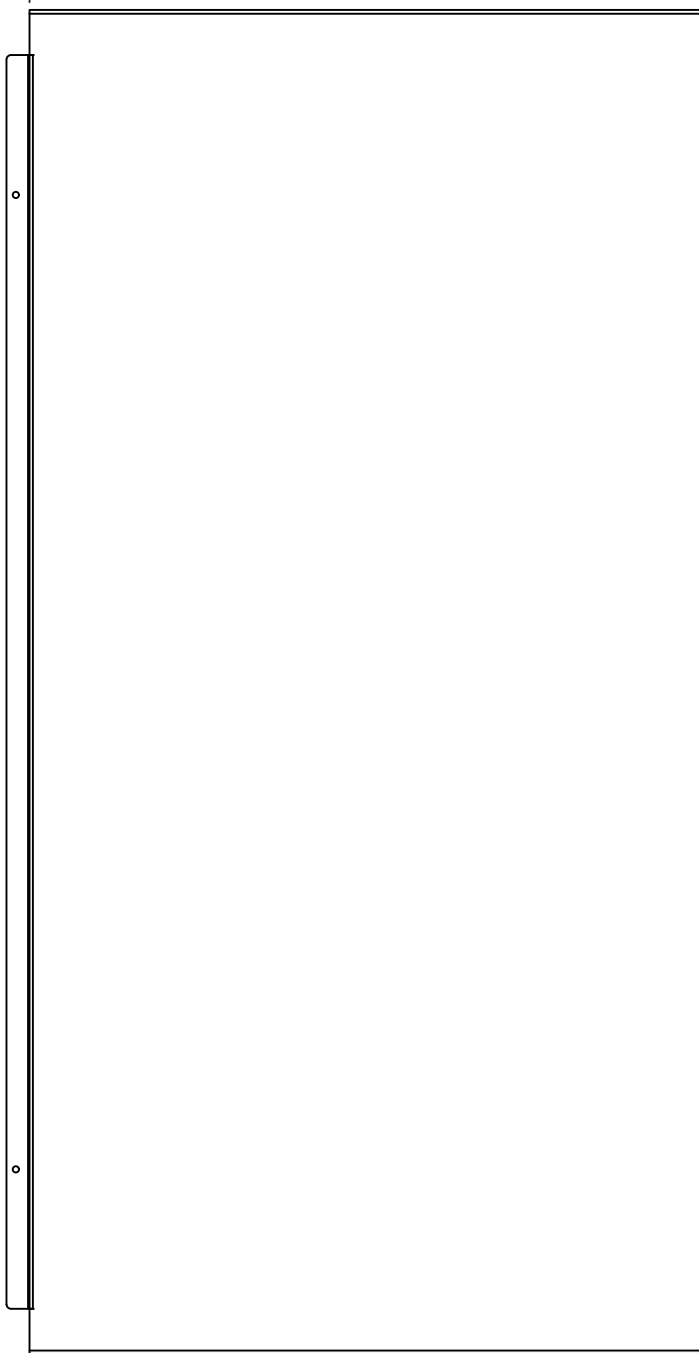

FRONT

0.000

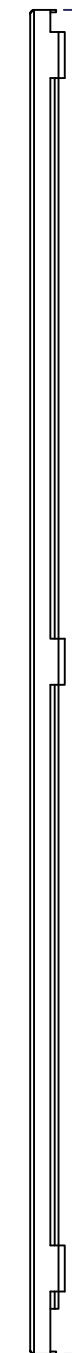

RIGHT

36.375

0.000

No.	Revisions	Date	By/Par

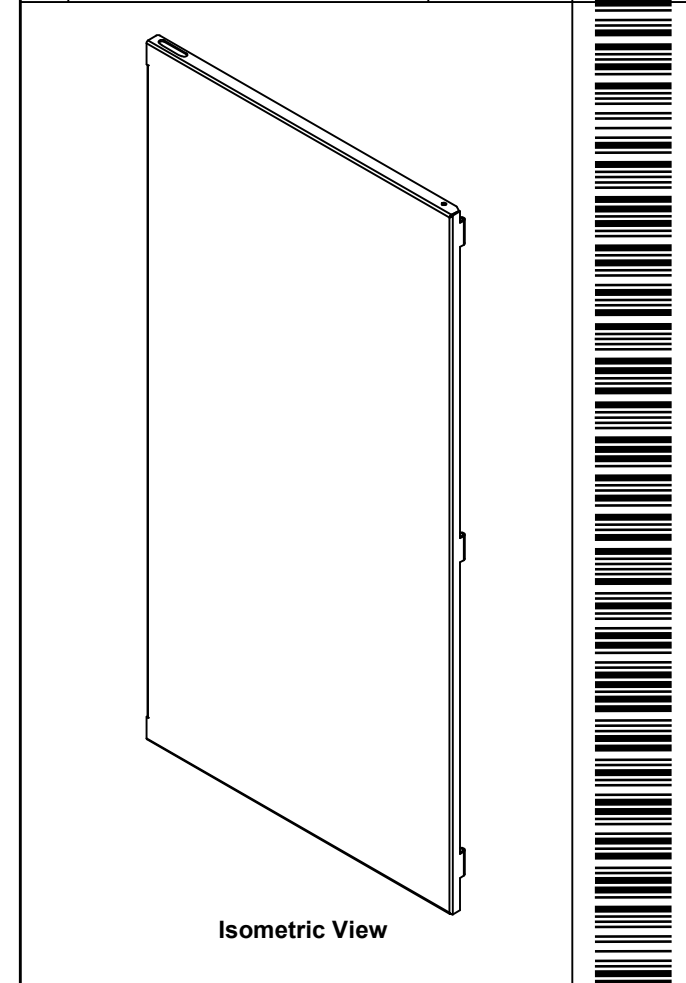

Isometric View

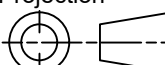

 Tél: (450) 979-4373 Fax: (450) 979-4626 www.exmweb.com		Flatness Aplatissement Max 3.0mm Projection 
Customer Client	Date	
Drawn By Dessiné Par	BoxCad: BoxCad	Date 27-Nov-24
Material Matière	14 Ga Cold Rolled A1008 CS Type B (1.7mm)	
Color Couleur	Asa-61 Grey	Finish Fini Smooth
Description 1100MCHQDD 36" x 36" Cover		Detail Rev.
Part Number Numéro Pièce	Rev. 0	9 10

SEE BILL OF MATERIAL ON LAST PAGE

1100MCHQDD363612FD

This drawing is confidential and must not be reproduced or used without the consent of EXM

Ce dessin est confidentiel et ne doit pas être reproduit ou utilisé sans le consentement de EXM

No.	Revisions	Date	By/Par

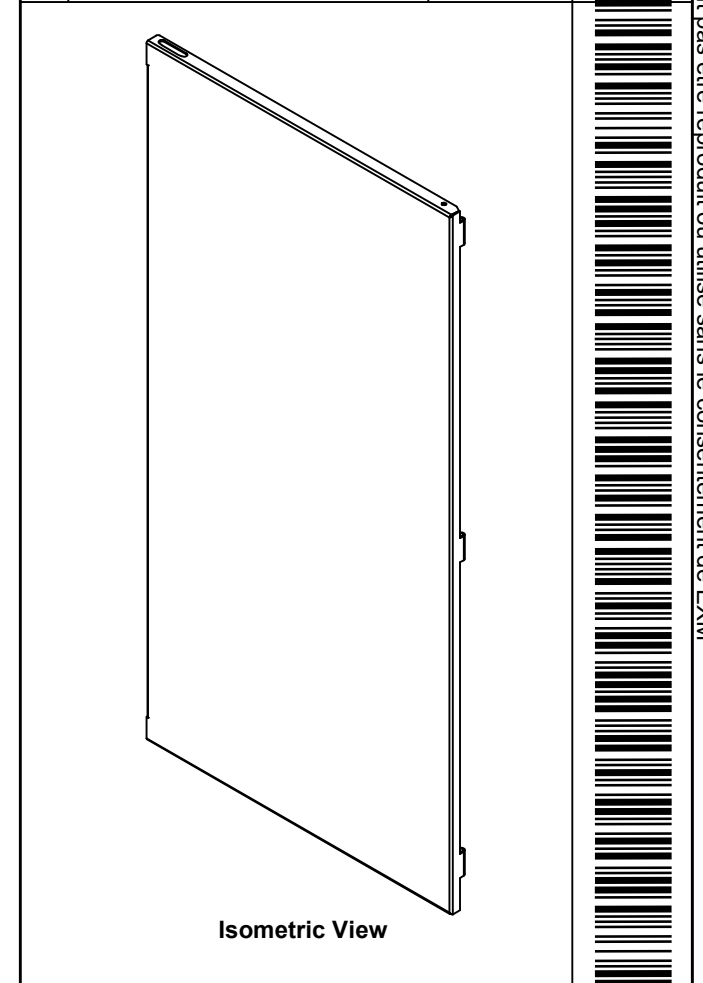

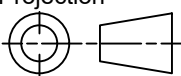
 Tél: (450) 979-4373 Fax: (450) 979-4626 www.exmweb.com		Flatness Aplatissement Max 3.0mm Projection 
Customer Client	Date	
Drawn By Dessiné Par	BoxCad: BoxCad	Date 27-Nov-24
Material Matière	14 Ga Cold Rolled A1008 CS Type B (1.7mm)	
Color Couleur	Asa-61 Grey	Finish Fini Smooth
Description		Detail Rev.
1100MCHQDD 36" x 36" Cover		
Part Number Numéro Pièce	Rev.	10
1100MCHQDD363612FD	0	10

QTY	Part Number	Rev	Description
1	STK-P-02400S	0	Powder Paint (Asa-61 Grey / Smooth)
1	1100MCHQDD363612FD-P	0	1100MCHQDD 36" x 36" x 12" Flange Cover Part
Parts List			

This drawing is confidential and must not be reproduced or used without the consent of EXM

Ce dessin est confidentiel et ne doit pas être reproduit ou utilisé sans le consentement de EXM

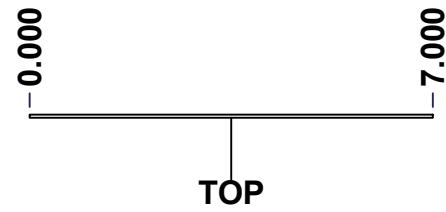

TOP

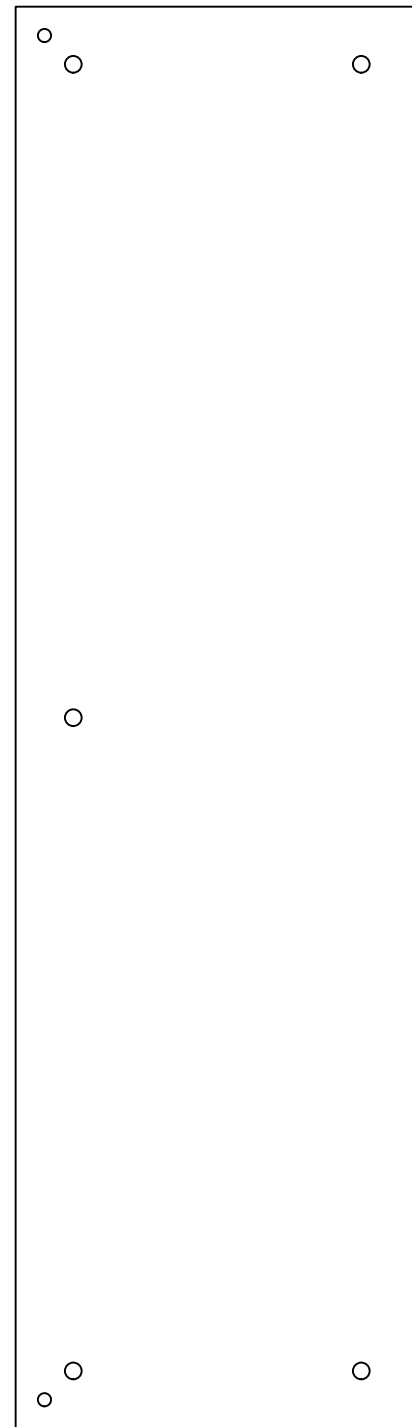

FRONT

24.685

0.000

RIGHT

No.	Revisions	Date	By/Par

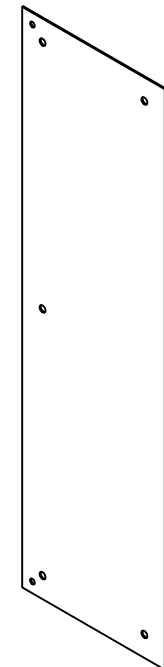

Isometric View



Tél: (450) 979-4373
 Fax: (450) 979-4626
 www.exmweb.com

Flatness
Aplatissement

Max 3.0mm

Projection

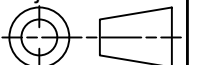

Customer Client	Date
Drawn By Dessiné Par BoxCad	Date
Material Matière	See Part List
Color Couleur	See Part List
Finish Fini	See Part List

Description	Detail Rev.
1100MCHQ Accessory Plate	

Qty	Part Number	Rev.	Description	Material	Color	Finish
1	881SPCHQ1-P	0	1100 MCHQ - Accessory Plate	16 Ga H.R.P. & O.	Asa-61 Grey	Smooth

Parts List

Part Number Numéro Pièce	Rev.	1
881SPCHQ1	0	2

This drawing is confidential and must not be reproduced or used without the consent of EXM

Ce dessin est confidentiel et ne doit pas être reproduit ou utilisé sans le consentement de EXM

HOLE TABLE			
CUT-OUT	XDIM	YDIM	DESCRIPTION
1	1.000	1.000	GROUND HOLE (RND Ø0.290)
2	6.000	1.000	GROUND HOLE (RND Ø0.290)
3	1.000	23.685	GROUND HOLE (RND Ø0.290)
4	6.000	23.685	GROUND HOLE (RND Ø0.290)
5	1.000	12.343	GROUND HOLE (RND Ø0.290)

All knockouts are actual size / Les disques défonçables sont grandeur réel

No.	Revisions	Date	By/Par

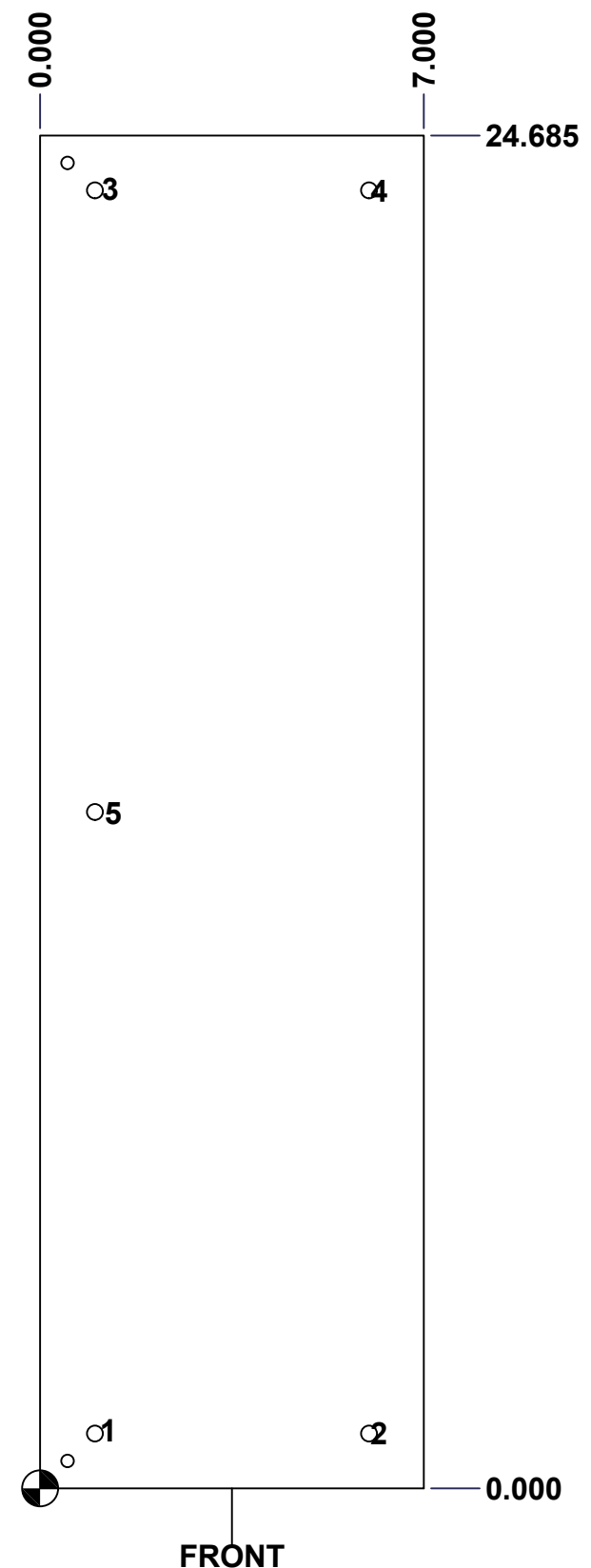

Isometric View

<p>Tél: (450) 979-4373 Fax: (450) 979-4626 www.exmweb.com</p>		Flatness Aplatissement Max 3.0mm Projection
Customer Client		Date
Drawn By Dessiné Par	BoxCad	Date
Material Matière	See Part List	
Color Couleur	See Part List	Finish Fini See Part List
Description 1100MCHQ Accessory Plate		Detail Rev.
Part Number Numéro Pièce	881SPCHQ1	Rev. 2 0

This drawing is confidential and must not be reproduced or used without the consent of EXM

Ce dessin est confidentiel et ne doit pas être reproduit ou utilisé sans le consentement de EXM

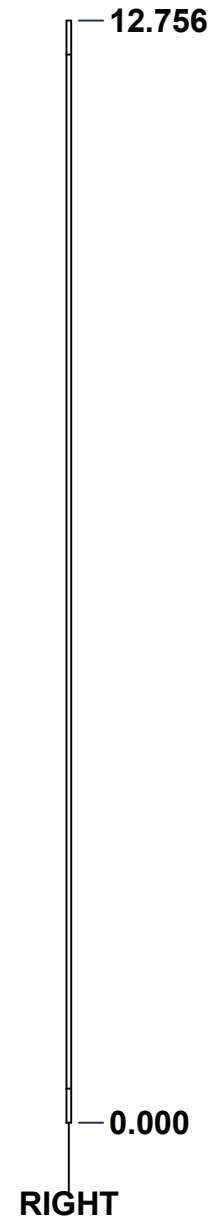
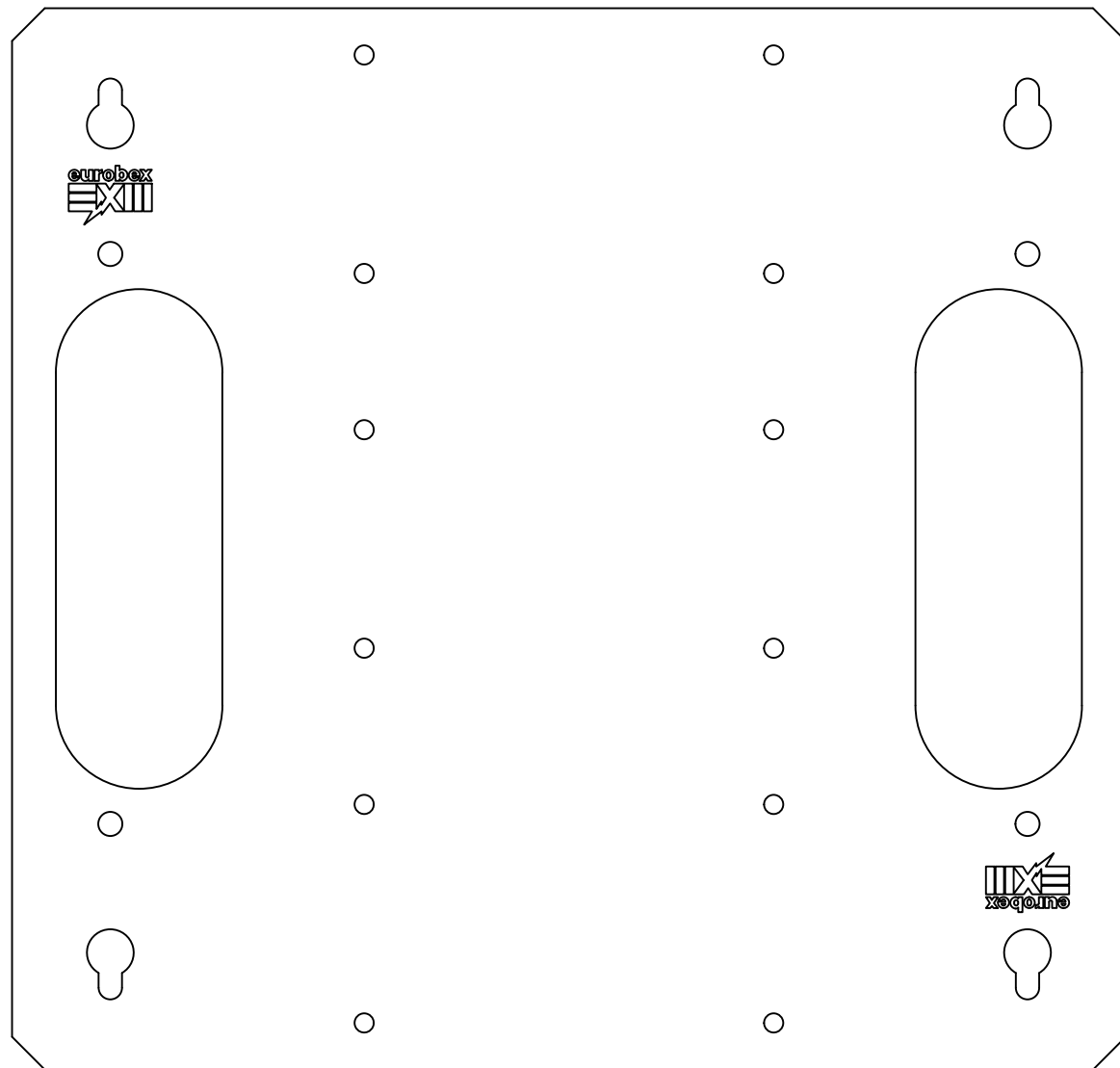
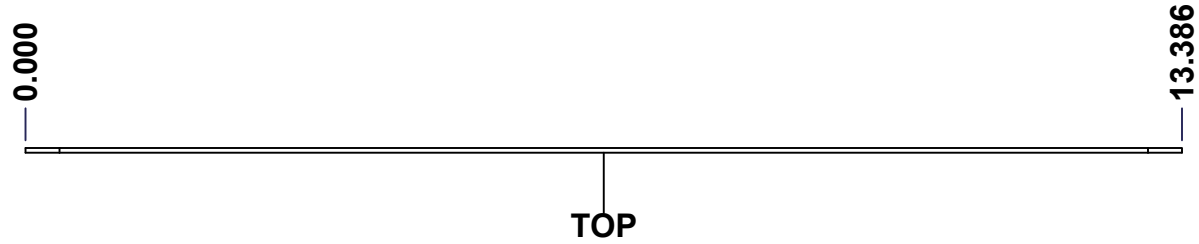

No.	Revisions	Date	By/Par

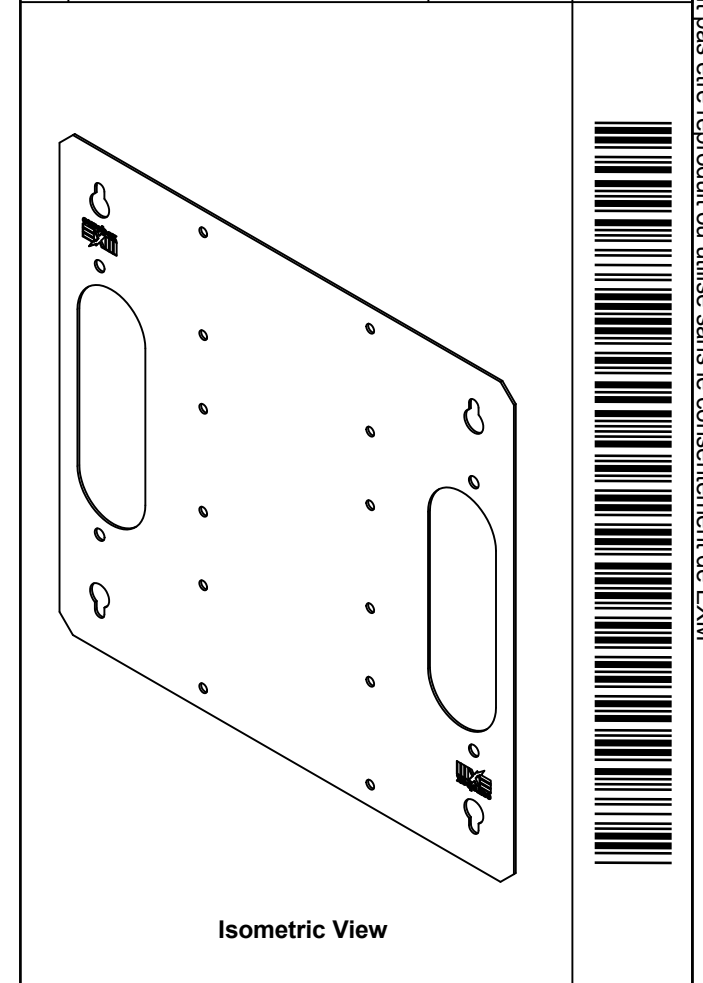

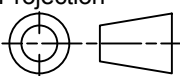
 Tél: (450) 979-4373 Fax: (450) 979-4626 www.exmweb.com	Flatness Aplatissement Max 3.0mm
	Projection 
Customer Client	Date
Drawn By Dessiné Par BoxCad	Date
Material Matière	See Part List
Color Couleur	See Part List
Finish Fini	See Part List
Description	Detail Rev.
1100MCHQ Universal support current panel	
Part Number Numéro Pièce	Rev.
881SPCHQ2	0

Qty	Part Number	Rev.	Description	Material	Color	Finish
1	881SPCHQ2-P	0	1100 MCHQ - Universal Support (Current)	16 Ga H.R.P. & O.	Asa-61 Grey	Smooth
Parts List						

This drawing is confidential and must not be reproduced or used without the consent of EXM

Ce dessin est confidentiel et ne doit pas être reproduit ou utilisé sans le consentement de EXM

HOLE TABLE			
CUT-OUT	XDIM	YDIM	DESCRIPTION
1	4.232	12.195	RND Ø0.230
2	4.232	9.569	RND Ø0.230
3	4.232	7.691	RND Ø0.230
4	4.232	5.065	RND Ø0.230
5	4.232	3.187	RND Ø0.230
6	4.232	0.561	RND Ø0.230
7	9.154	12.195	RND Ø0.230
8	9.154	9.569	RND Ø0.230
9	9.154	7.691	RND Ø0.230
10	9.154	5.065	RND Ø0.230
11	9.154	3.187	RND Ø0.230
12	9.154	0.561	RND Ø0.230
13	1.181	9.803	RND Ø0.290
14	1.181	2.953	RND Ø0.290
15	12.205	9.803	RND Ø0.290
16	12.205	2.953	RND Ø0.290
17	1.528	6.378	SLT 6.004 x 2.000 @90°
18	11.858	6.378	SLT 6.004 x 2.000 @90°
19	1.181	1.406	GROUND HOLE
20	1.181	11.350	GROUND HOLE
21	12.205	1.406	GROUND HOLE
22	12.205	11.350	GROUND HOLE

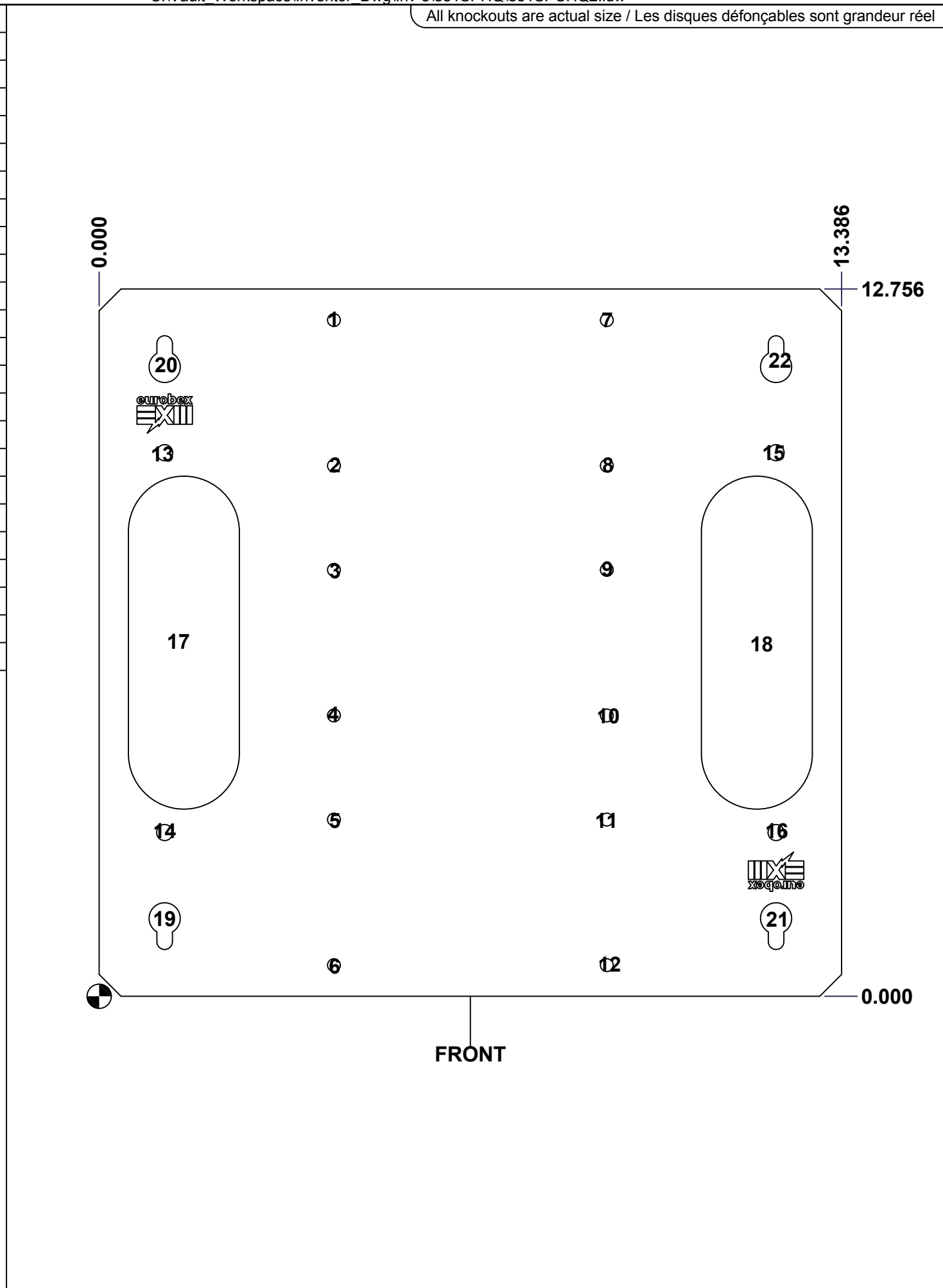

All knockouts are actual size / Les disques défonçables sont grandeur réel

No.	Revisions	Date	By/Par

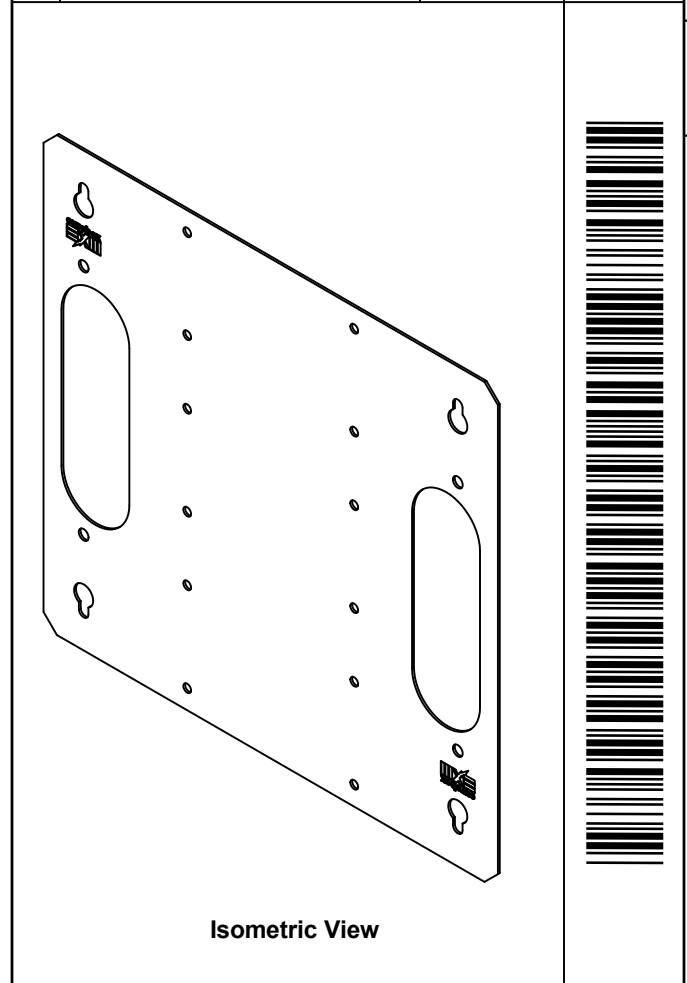

		Flatness Aplatissement Max 3.0mm Projection 	
Customer Client		Date	
Drawn By Dessiné Par BoxCad		Date	
Material Matière See Part List			
Color Couleur See Part List		Finish Fini See Part List	
Description 1100MCHQ Universal support current panel			Detail Rev.
Part Number Numéro Pièce 881SPCHQ2			Rev. 2 0

This drawing is confidential and must not be reproduced or used without the consent of EXM

Tolerance ±1/32" unless otherwise specified

C:\Vault Workspace\Inventor Dwg\Inv-8\881SPHQ\881SPCHQ3.idw

Tolérance ±1/32" sauf spécification contraire

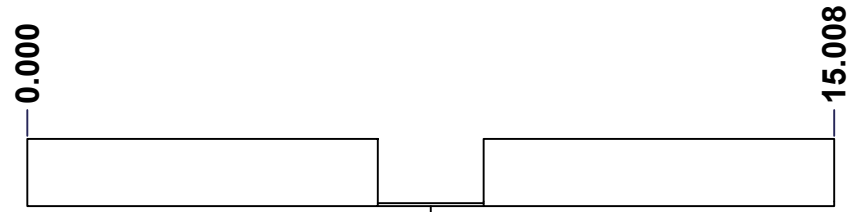

TOP

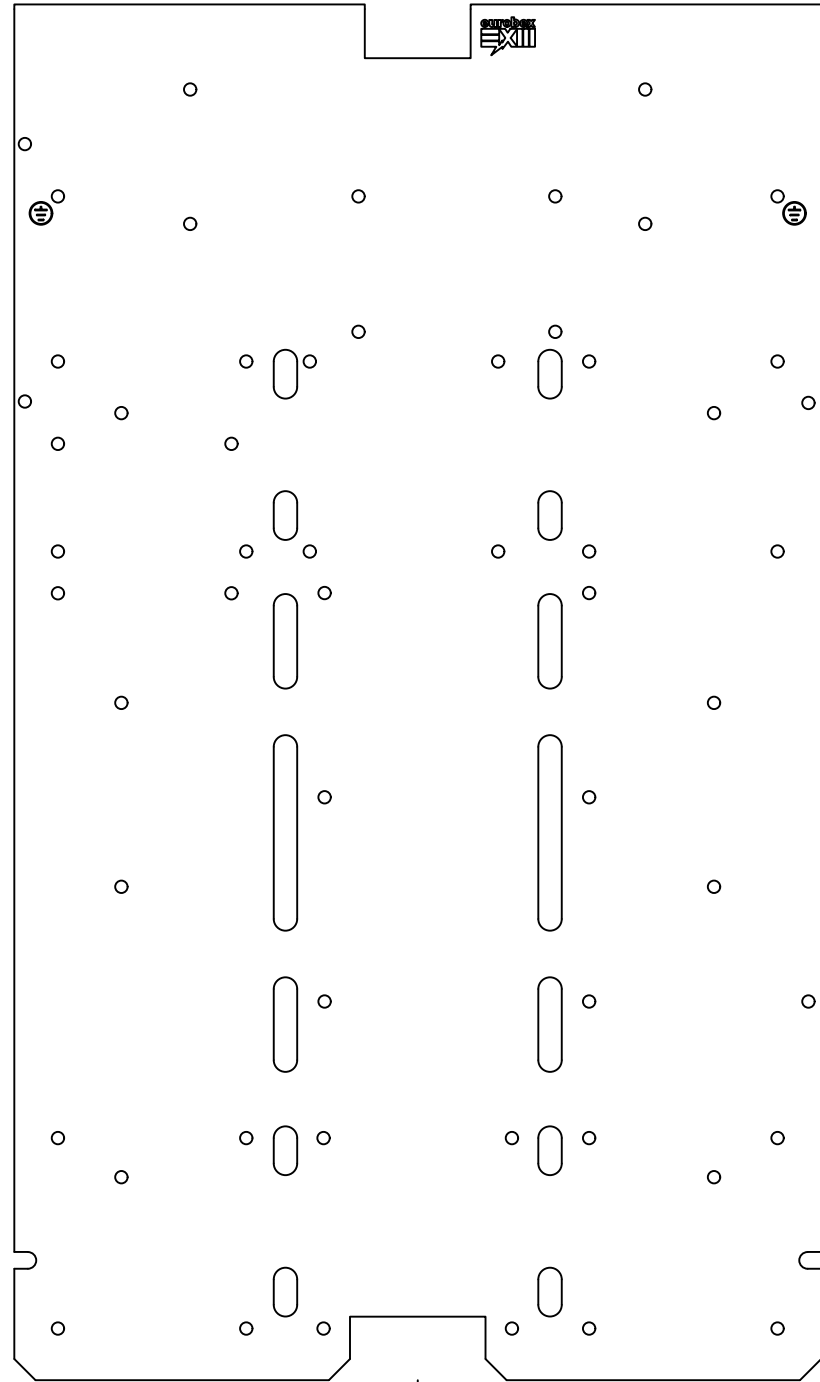

FRONT

25.591
24.841

0.000

RIGHT

No.	Revisions	Date	By/Par

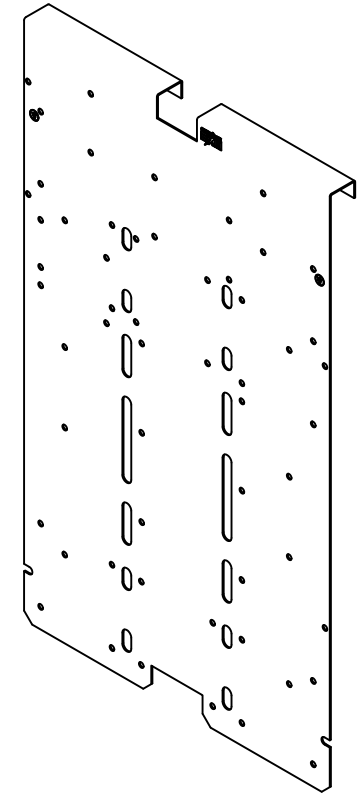

Isometric View



Ce dessin est confidentiel et ne doit pas être reproduit ou utilisé sans le consentement de EXM



Tél: (450) 979-4373
Fax: (450) 979-4626
www.exmweb.com

Flatness
Aplatissement

Max 3.0mm

Projection

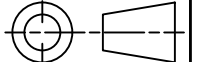

Customer Client	Date
Drawn By Dessiné Par BoxCad	Date
Material Matière	See Part List
Color Couleur	See Part List
Finish Fini	See Part List

Description	Detail Rev.
1100MCHQ Universal support voltage panel	

Qty	Part Number	Rev.	Description	Material	Color	Finish
1	881SPCHQ3-P	0	1100 MCHQ - Universal Support (Voltage)	16 Ga H.R.P. & O.	Asa-61 Grey	Smooth

Parts List

Part Number Numéro Pièce	Rev.	1
881SPCHQ3	0	3

This drawing is confidential and must not be reproduced or used without the consent of EXM

Ce dessin est confidentiel et ne doit pas être reproduit ou utilisé sans le consentement de EXM

HOLE TABLE			
CUT-OUT	XDIM	YDIM	DESCRIPTION
1	0.811	0.961	RND Ø0.230
2	4.315	0.961	RND Ø0.230
3	5.752	0.961	RND Ø0.230
4	9.256	0.961	RND Ø0.230
5	10.693	0.961	RND Ø0.230
6	14.197	0.961	RND Ø0.230
7	0.811	4.504	RND Ø0.230
8	1.992	3.776	RND Ø0.230
9	4.315	4.504	RND Ø0.230
10	5.752	4.504	RND Ø0.230
11	9.256	4.504	RND Ø0.230
12	10.693	4.504	RND Ø0.230
13	13.016	3.776	RND Ø0.230
14	14.197	4.504	RND Ø0.230
15	1.992	9.177	RND Ø0.230
16	5.772	7.043	RND Ø0.230
17	10.693	7.043	RND Ø0.230
18	14.772	7.043	RND Ø0.230
19	13.016	9.177	RND Ø0.230
20	5.772	10.843	RND Ø0.230
21	10.693	10.843	RND Ø0.230
22	1.992	12.598	RND Ø0.230
23	13.016	12.598	RND Ø0.230
24	0.811	14.638	RND Ø0.230
25	0.811	15.413	RND Ø0.230
26	4.039	14.638	RND Ø0.230
27	4.315	15.413	RND Ø0.230
28	5.772	14.638	RND Ø0.230
29	5.496	15.413	RND Ø0.230
30	9.000	15.413	RND Ø0.230
31	10.693	14.638	RND Ø0.230
32	10.693	15.413	RND Ø0.230
33	14.197	15.413	RND Ø0.230
34	0.811	17.417	RND Ø0.230
35	0.197	18.205	RND Ø0.230
36	1.992	17.988	RND Ø0.230
37	0.811	18.949	RND Ø0.230
38	4.039	17.417	RND Ø0.230
39	4.315	18.949	RND Ø0.230
40	5.496	18.949	RND Ø0.230
41	6.402	19.500	RND Ø0.230
42	9.000	18.949	RND Ø0.230
43	10.063	19.500	RND Ø0.230
44	10.693	18.949	RND Ø0.230
45	13.016	17.988	RND Ø0.230
46	14.197	18.949	RND Ø0.230
47	14.772	18.177	RND Ø0.230
48	0.197	22.992	RND Ø0.230
49	0.811	22.020	RND Ø0.230
50	3.272	21.508	RND Ø0.230
51	3.272	24.008	RND Ø0.230
52	6.402	22.020	RND Ø0.230

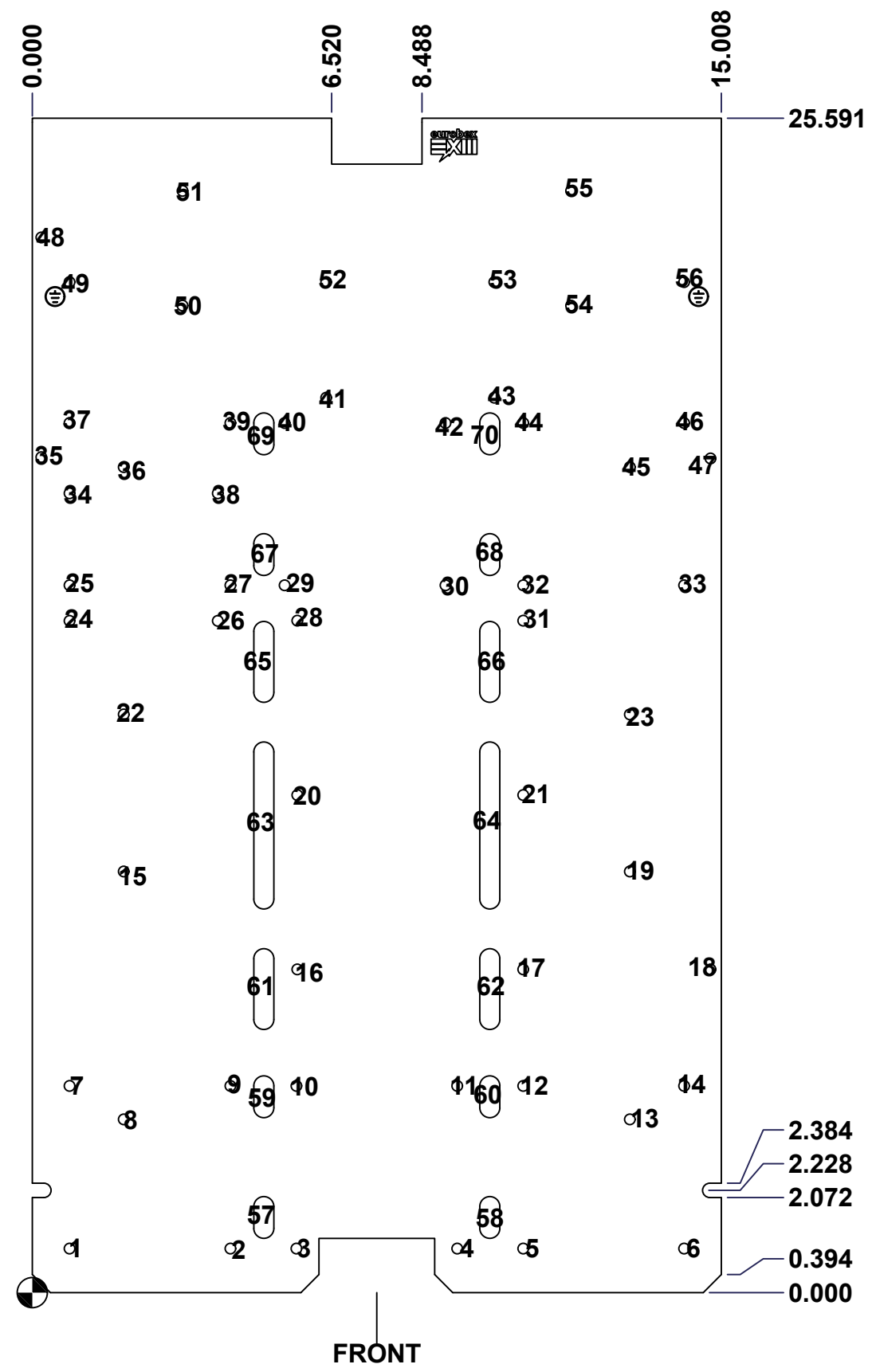

All knockouts are actual size / Les disques défonçables sont grandeur réel

No.	Revisions	Date	By/Par

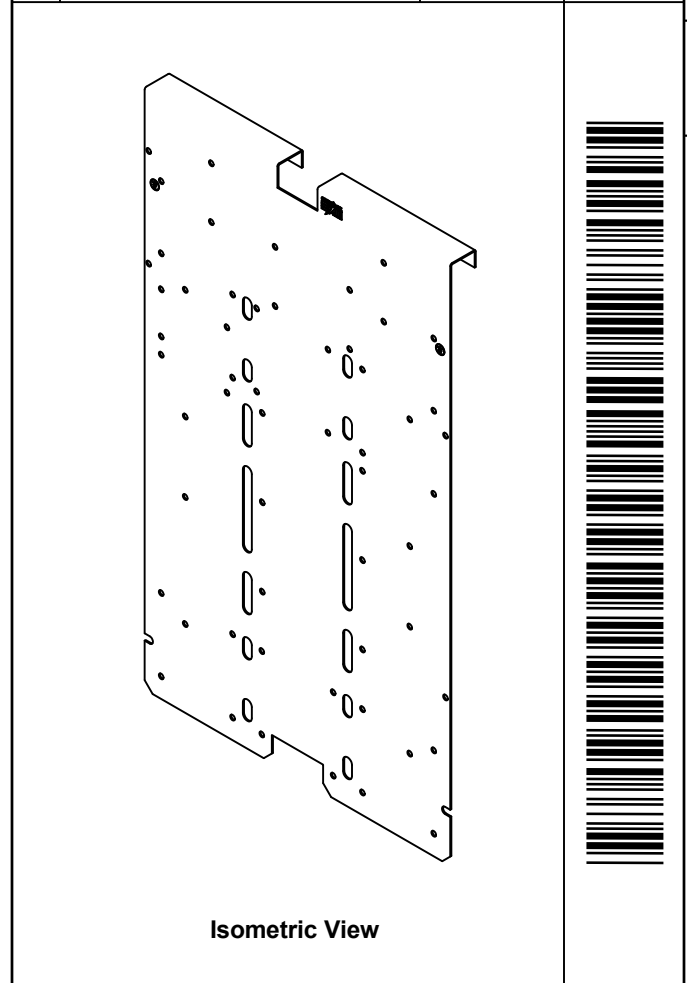

		Tél: (450) 979-4373 Fax: (450) 979-4626 www.exmweb.com		Flatness Aplatissement Max 3.0mm Projection 	
Customer		Date		Date	
Client		Date		Date	
Drawn By		BoxCad		Date	
Dessiné Par		BoxCad		Date	
Material		See Part List			
Matière		See Part List			
Color		See Part List		Finish	
Couleur		See Part List		Fini	
See Part List		See Part List		See Part List	
Description				Detail Rev.	
1100MCHQ Universal support voltage panel					
Part Number				Rev.	
Numéro Pièce				2	
881SPCHQ3				0	
				3	

This drawing is confidential and must not be reproduced or used without the consent of EXM

Ce dessin est confidentiel et ne doit pas être reproduit ou utilisé sans le consentement de EXM

HOLE TABLE

53	10.063	22.020	RND Ø0.230
54	11.736	21.508	RND Ø0.230
55	11.736	24.008	RND Ø0.230
56	14.197	22.020	RND Ø0.230
57	5.043	1.638	SLT 0.909 x 0.437 @90°
58	9.965	1.638	SLT 0.909 x 0.437 @90°
59	5.43	4.268	SLT 0.909 x 0.437 @90°
60	9.965	4.268	SLT 0.909 x 0.437 @90°
61	5.043	6.614	SLT 1.760 x 0.437 @90°
62	9.965	6.614	SLT 1.760 x 0.437 @90°
63	5.043	10.179	SLT 3.638 x 0.437 @90°
64	9.965	10.179	SLT 3.638 x 0.437 @90°
65	5.043	13.744	SLT 1.760 x 0.437 @90°
66	9.965	13.744	SLT 1.760 x 0.437 @90°
67	5.043	16.083	SLT 0.909 x 0.437 @90°
68	9.965	16.083	SLT 0.909 x 0.437 @90°
69	5.043	18.713	SLT 0.909 x 0.437 @90°
70	9.965	18.713	SLT 0.909 x 0.437 @90°

All knockouts are actual size / Les disques défonçables sont grandeur réel

No.	Revisions	Date	By/Par

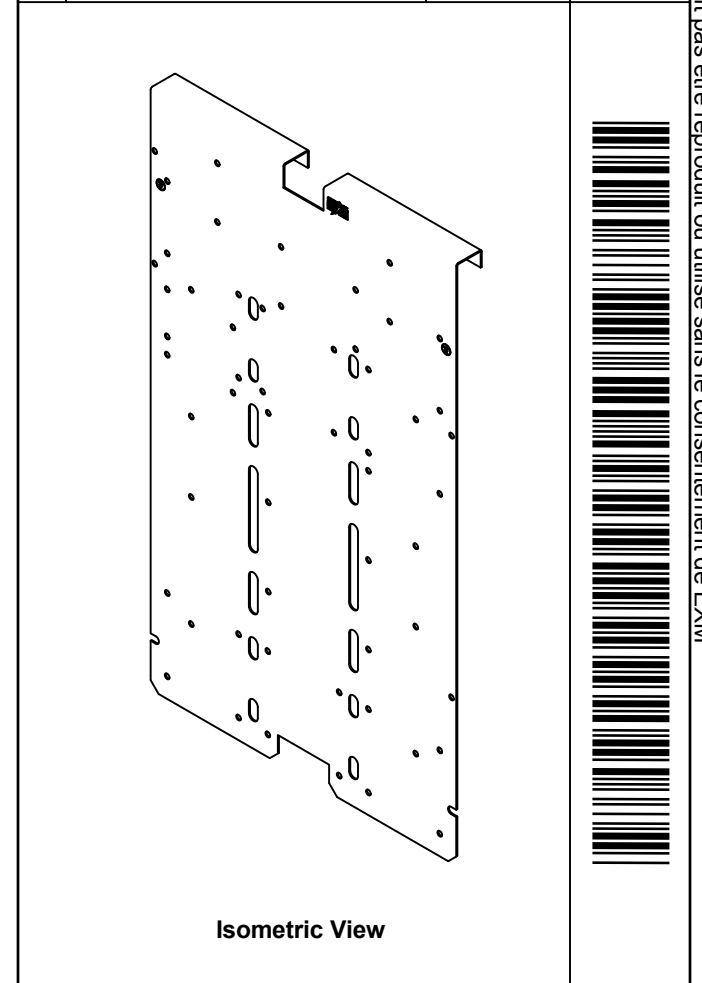
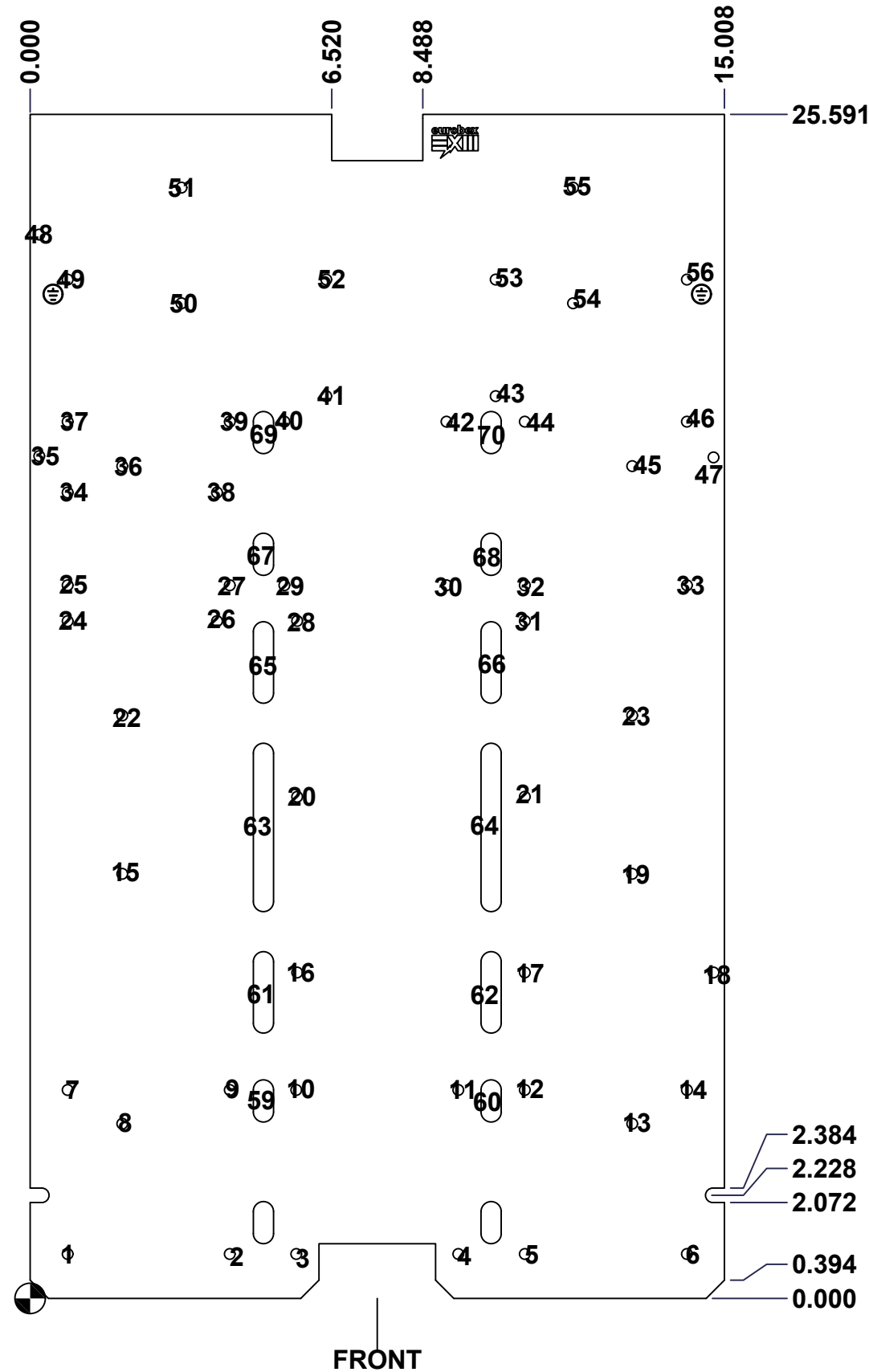

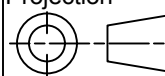
 Tél: (450) 979-4373 Fax: (450) 979-4626 www.exmweb.com		Flatness Aplatissement Max 3.0mm Projection 
Customer Client	Date	
Drawn By Dessiné Par	BoxCad	Date
Material Matière	See Part List	
Color Couleur	See Part List	Finish Fini
Description		Detail Rev.
1100MCHQ Universal support voltage panel		
Part Number Numéro Pièce	Rev.	3
881SPCHQ3	0	3