

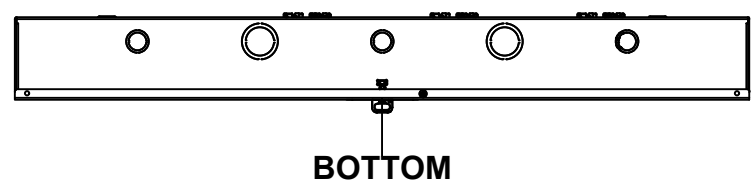

This drawing is confidential and must not be reproduced or used without the consent of EXM

Ce dessin est confidentiel et ne doit pas être reproduit ou utilisé sans le consentement de EXM

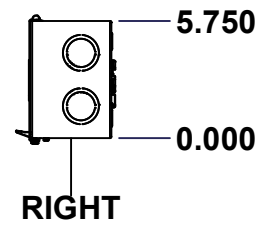
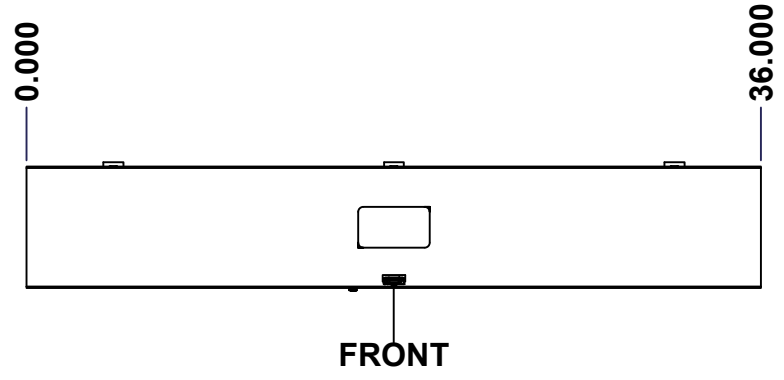
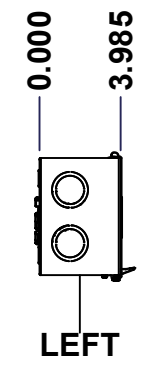
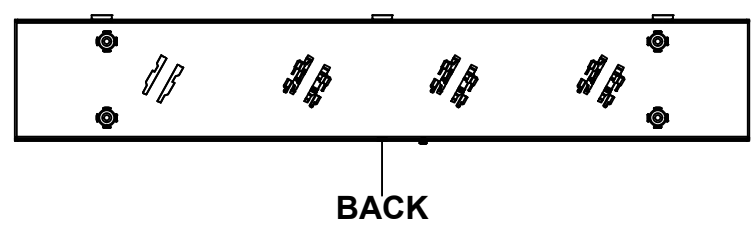
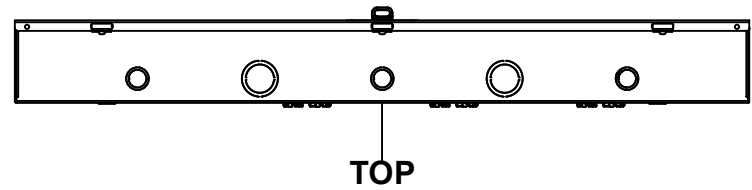
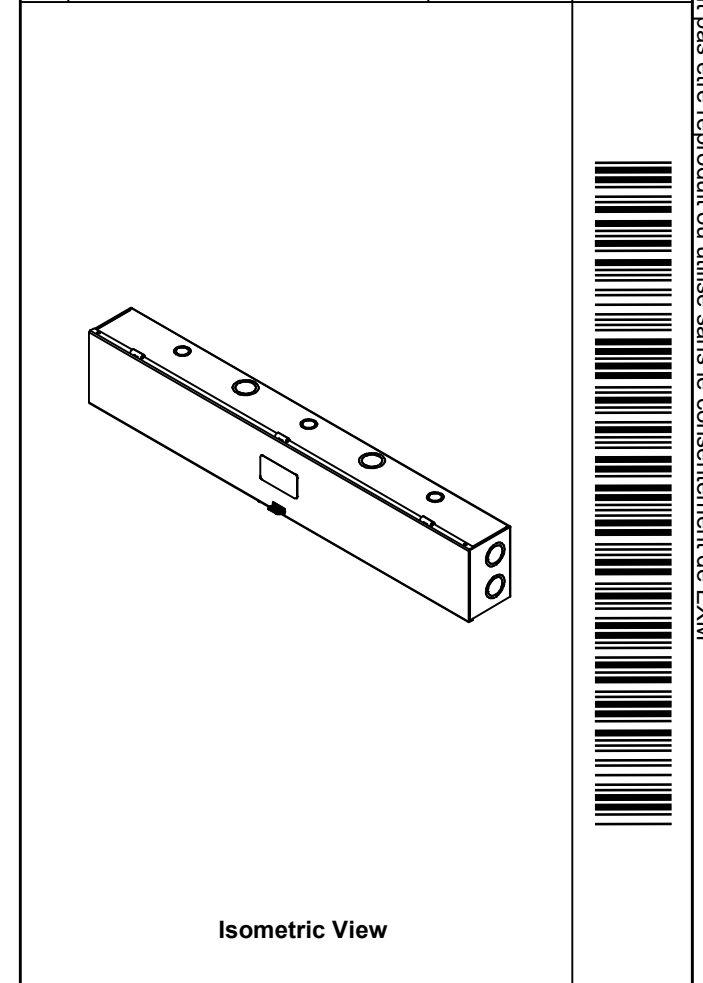

No.	Revisions	Date	By/Par

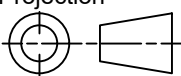

 Tél: (450) 979-4373 Fax: (450) 979-4626 <a href="http://www.exmweb.com">www.exmweb.com</a>		Flatness Aplatissement
		Max 3.0mm
Projection 		Date
Customer Client	BoxCad: BoxCad	Date
Drawn By Dessiné Par	BoxCad: BoxCad	Date 04-Dec-23
Material Matière	16 Ga Cold Rolled A1008 CS Type B (1.4mm)	
Color Couleur	Asa-61 Grey	Finish Fini Smooth
Description	Detail Rev.	
1100T 5.75" x 36" x 3.985" Assembly		
Part Number Numéro Pièce	Rev. 0	1 / 10

**SEE BILL OF MATERIAL ON LAST PAGE**

**1100T3103**

This drawing is confidential and must not be reproduced or used without the consent of EXM

Ce dessin est confidentiel et ne doit pas être reproduit ou utilisé sans le consentement de EXM

NOTE	
ITEM	DESCRIPTION
1	NEMA 1 Enclosure (IP20)
2	C/W Standard ground studs on box and cover
3	W/O Inner panel
4	W/O Inner panel mounting studs

No.	Revisions	Date	By/Par

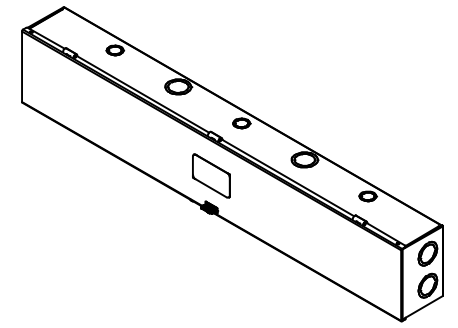
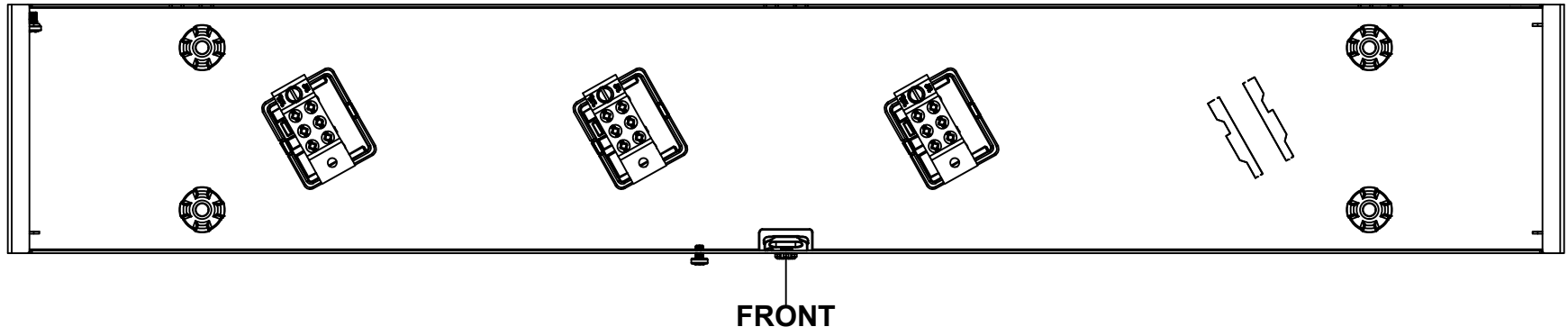

PACKING		
ITEM	QTY	DESCRIPTION
Cardboard sleeve	2	Top and Bottom
Cardboard strip	2	Between back of enclosure and inner panel
Plastic bag	1	To protect cover surface and inside gasket
Cardboard corner	4	To reinforced for the plastic strap tightening
Plastic strap - Black	2	To Squeeze the 2 cardboard sleeve together
Packaging label	3	White label with PN
Plastic strap- Green	2	To secure the enclosure to the wood pallet
Wood Pallet	1	2" deeper and 3" larger than enclosure size

1	STK-Q-77450	3	Plastic Padlock Provision
1	1100T3103C	0	1100T 18" x 36" Cover
1	STK-K-02700	0	1412 T Accessory Kit
1	1100T3103B	0	1100T 5.75" x 36" x 3.985" Body
3	881 BRC125	0	Aluminum Lug with Insulator
Qty	Part Number	Rev	Description
Parts List			



Tél: (450) 979-4373  
Fax: (450) 979-4626  
[www.exmweb.com](http://www.exmweb.com)

Flatness  
Aplatissement  
Max 3.0mm

Projection

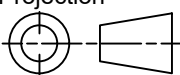

Customer Client	Date
Drawn By Dessiné Par BoxCad: BoxCad	Date 04-Dec-23
Material Matière 16 Ga Cold Rolled A1008 CS Type B (1.4mm)	
Color Couleur Asa-61 Grey	Finish Fini Smooth
Description 1100T 5.75" x 36" x 3.985" Assembly	Detail Rev.
Part Number Numéro Pièce <b>1100T3103</b>	Rev. <b>0</b> / 2

This drawing is confidential and must not be reproduced or used without the consent of EXM

Ce dessin est confidentiel et ne doit pas être reproduit ou utilisé sans le consentement de EXM

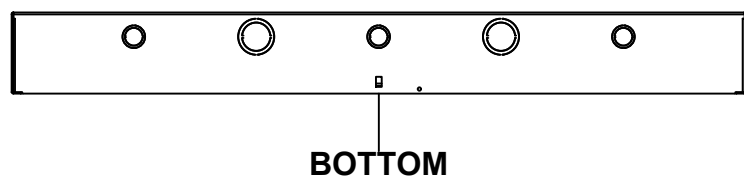
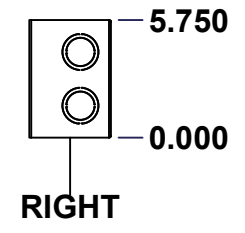
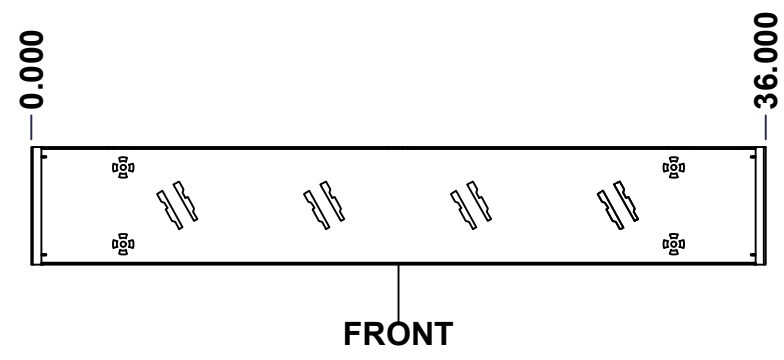
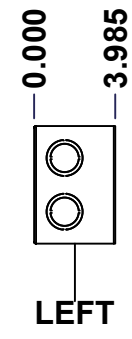
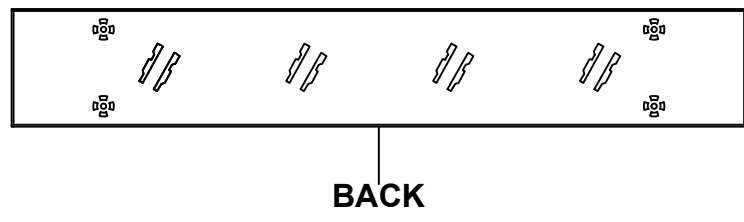
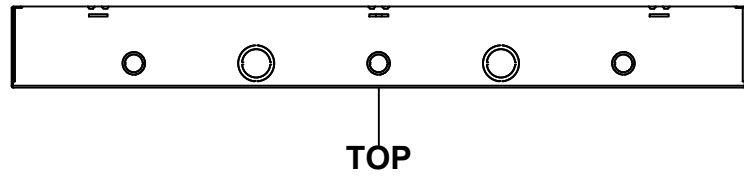

No.	Revisions	Date	By/Par

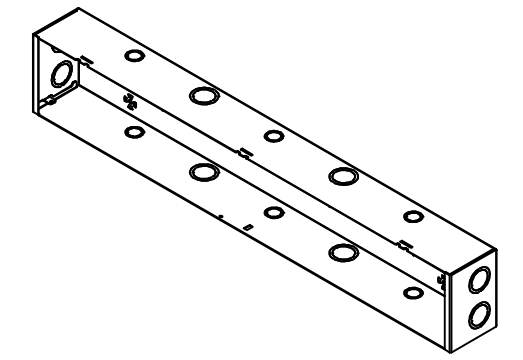

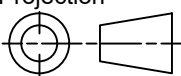
 Tél: (450) 979-4373 Fax: (450) 979-4626 <a href="http://www.exmweb.com">www.exmweb.com</a>	Flatness Aplatissement Max 3.0mm
	Projection 
Customer Client	Date
Drawn By Dessiné Par BoxCad: BoxCad	Date 04-Dec-23
Material Matière 16 Ga Cold Rolled A1008 CS Type B (1.4mm)	
Color Couleur Asa-61 Grey	Finish Fini Smooth
Description 1100T 5.75" x 36" x 3.985" Body	
Part Number Numéro Pièce <b>1100T3103B</b>	Detail Rev. Rev. 3 0

**SEE BILL OF MATERIAL ON LAST PAGE**

This drawing is confidential and must not be reproduced or used without the consent of EXM

Ce dessin est confidentiel et ne doit pas être reproduit ou utilisé sans le consentement de EXM

**STANDARD FEATURES ARE NOT LISTED IN THIS HOLE TABLE**

**HOLE TABLE - TOP VIEW (CUSTOM FEATURE ONLY)**

CUT-OUT	XDIM	YDIM	DESCRIPTION
1	30.000	1.188	DKO Ø1.125 - 0.875
2	24.000	1.188	DKO Ø1.750 - 1.375
3	18.000	1.188	DKO Ø1.125 - 0.875
4	12.000	1.188	DKO Ø1.750 - 1.375
5	6.000	1.188	DKO Ø1.125 - 0.875

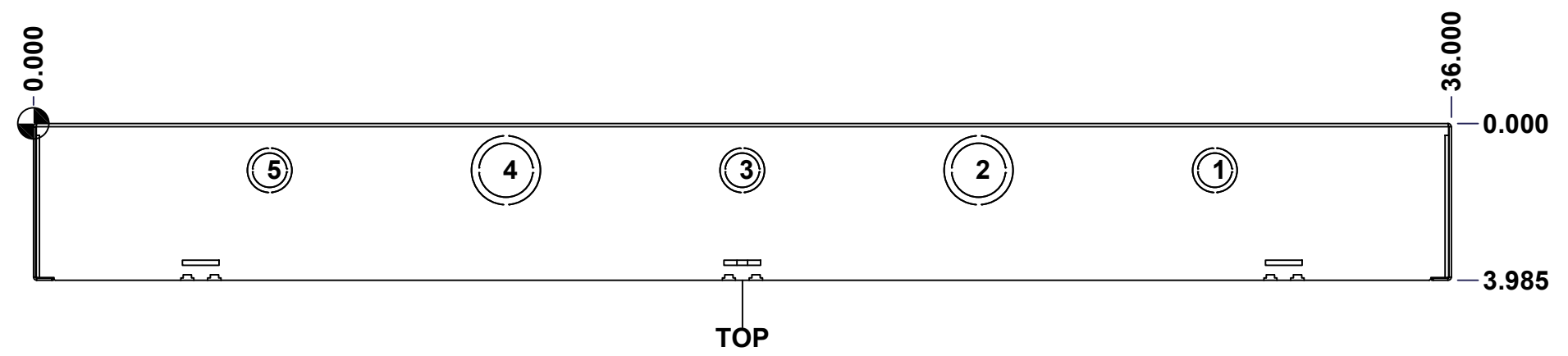

	Description	Status
	1100T 5.75" x 36" x 3.985" Body	(NULL)
	Part Number Numéro Pièce	Rev.
	<b>1100T3103B</b>	<b>0</b> / 4
		10

This drawing is confidential and must not be reproduced or used without the consent of EXM

Ce dessin est confidentiel et ne doit pas être reproduit ou utilisé sans le consentement de EXM

STANDARD FEATURES ARE NOT LISTED IN THIS HOLE TABLE			
HOLE TABLE - RIGHT VIEW (CUSTOM FEATURE ONLY)			
CUT-OUT	XDIM	YDIM	DESCRIPTION
1	1.500	4.188	DKO Ø1.750 - 1.375
2	1.500	1.563	DKO Ø1.750 - 1.375

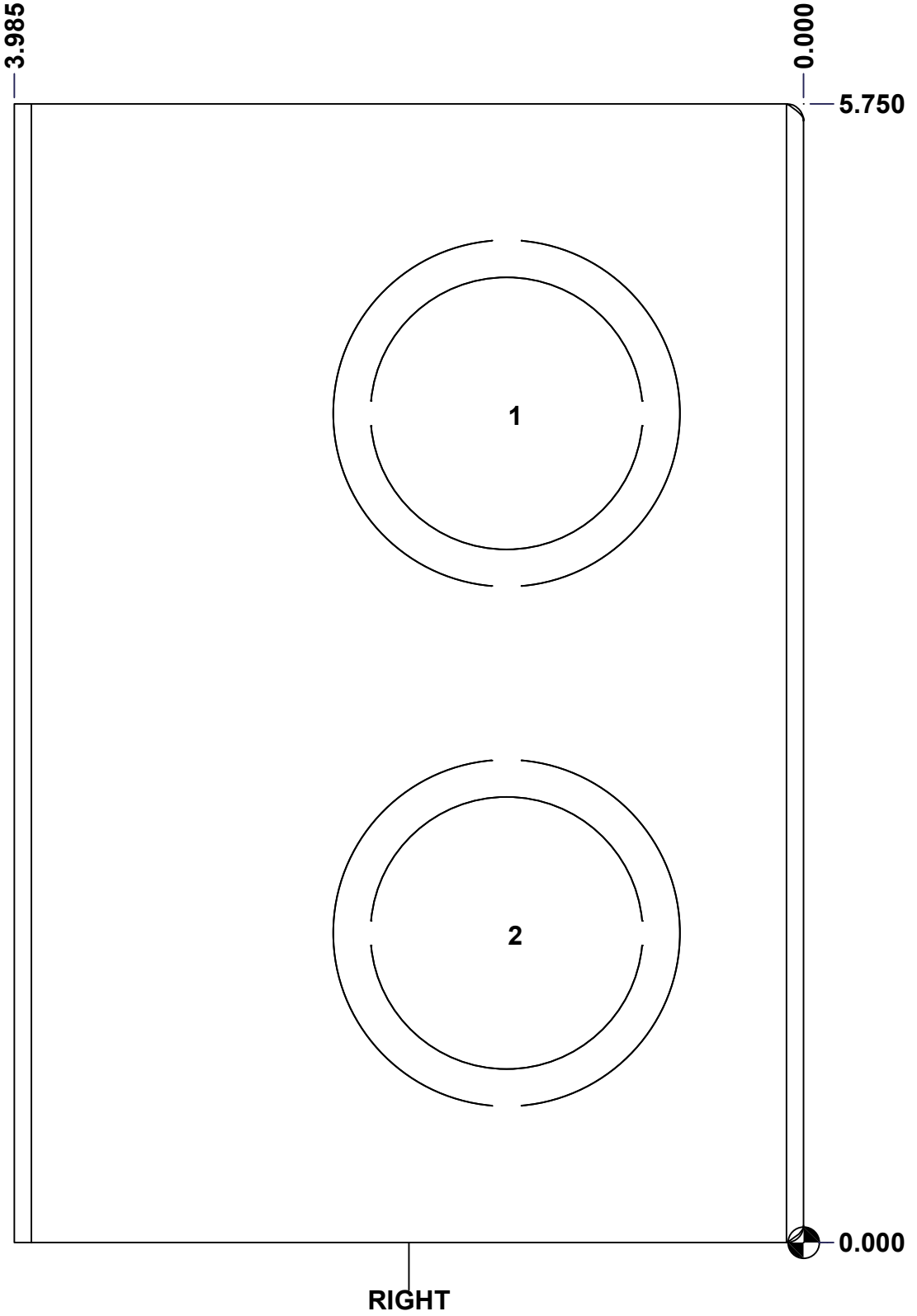

	Description	Status
	1100T 5.75" x 36" x 3.985" Body	(NULL)
	Part Number Numéro Pièce	Rev. 5
	<b>1100T3103B</b>	<b>0</b> / 10

This drawing is confidential and must not be reproduced or used without the consent of EXM

Ce dessin est confidentiel et ne doit pas être reproduit ou utilisé sans le consentement de EXM

**STANDARD FEATURES ARE NOT LISTED IN THIS HOLE TABLE**

**HOLE TABLE - BOTTOM VIEW (CUSTOM FEATURE ONLY)**

CUT-OUT	XDIM	YDIM	DESCRIPTION
1	30.000	1.188	DKO Ø1.125 - 0.875
2	24.000	1.188	DKO Ø1.750 - 1.375
3	18.000	1.188	DKO Ø1.125 - 0.875
4	12.000	1.188	DKO Ø1.750 - 1.375
5	6.000	1.188	DKO Ø1.125 - 0.875

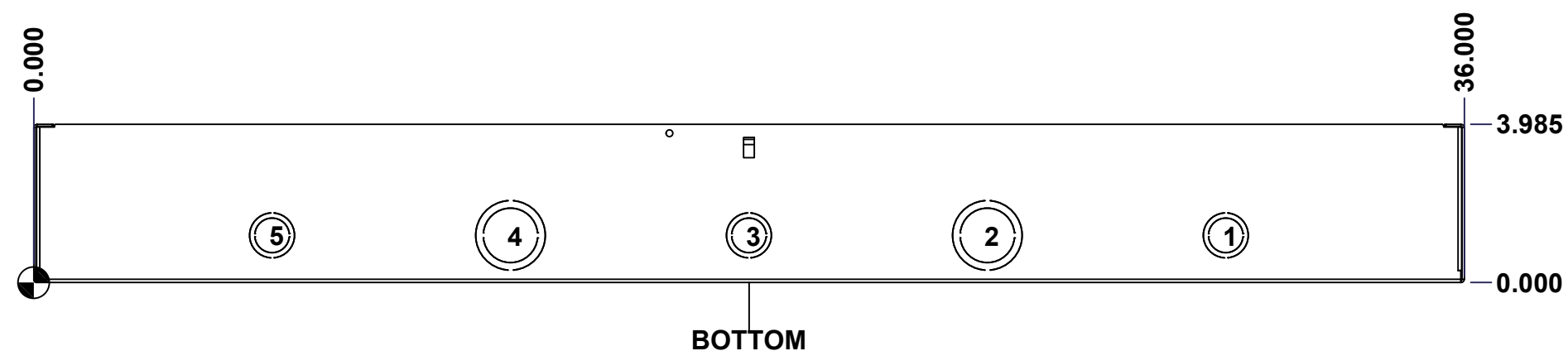

	Description	Status
	1100T 5.75" x 36" x 3.985" Body	(NULL)
	Part Number	Rev.
	Numéro Pièce	6
	<b>1100T3103B</b>	<b>0</b>
		10

This drawing is confidential and must not be reproduced or used without the consent of EXM

Ce dessin est confidentiel et ne doit pas être reproduit ou utilisé sans le consentement de EXM

STANDARD FEATURES ARE NOT LISTED IN THIS HOLE TABLE			
HOLE TABLE - LEFT VIEW (CUSTOM FEATURE ONLY)			
CUT-OUT	XDIM	YDIM	DESCRIPTION
1	1.500	4.188	DKO Ø1.750 - 1.375
2	1.500	1.563	DKO Ø1.750 - 1.375

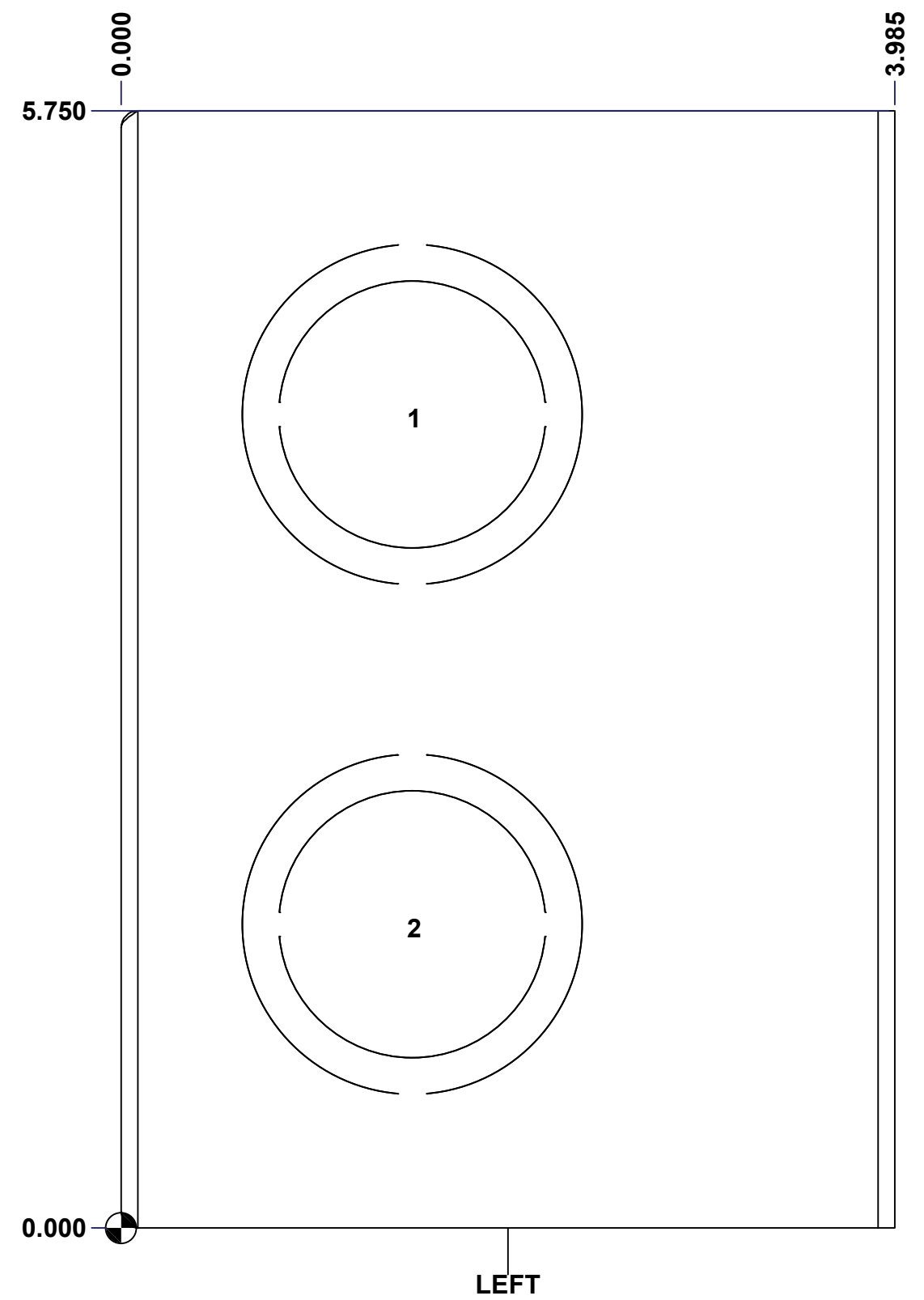

	Description	Status
	1100T 5.75" x 36" x 3.985" Body	(NULL)
	Part Number Numéro Pièce	Rev.
	<b>1100T3103B</b>	<b>0</b>
		7
		10

This drawing is confidential and must not be reproduced or used without the consent of EXM

Ce dessin est confidentiel et ne doit pas être reproduit ou utilisé sans le consentement de EXM

No.	Revisions	Date	By/Par

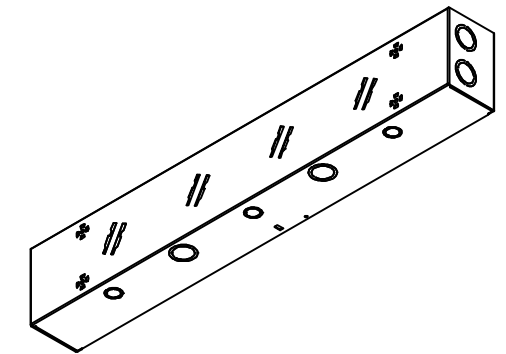

Isometric View

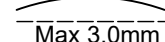

 Tél: (450) 979-4373 Fax: (450) 979-4626 <a href="http://www.exmweb.com">www.exmweb.com</a>		Flatness Aplatissement  Max 3.0mm
Customer Client		Date
Drawn By Dessiné Par BoxCad: BoxCad		Date 04-Dec-23
Material Matière 16 Ga Cold Rolled A1008 CS Type B (1.4mm)		
Color Couleur Asa-61 Grey	Finish Fini Smooth	
Description 1100T 5.75" x 36" x 3.985" Body		Detail Rev.
Part Number Numéro Pièce <b>1100T3103B</b>		Rev. 8 <b>0</b> / 10

Qty	Part Number	Rev	Description
1	STK-P-02400S	0	Powder Paint (Asa-61 Grey / Smooth)
1	STK-S-00100	0	3.5" x 2" Silver Milar Flexcon Sticker
1	1100T3103B-P	0	1100T 5.75" x 36" x 3.985" Body Part
Parts List			

This drawing is confidential and must not be reproduced or used without the consent of EXM

Ce dessin est confidentiel et ne doit pas être reproduit ou utilisé sans le consentement de EXM

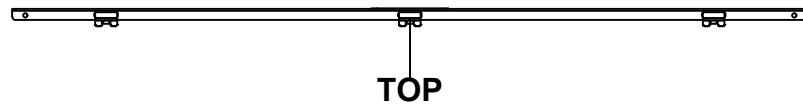

TOP

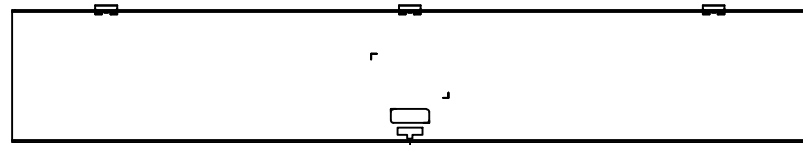

BACK



LEFT

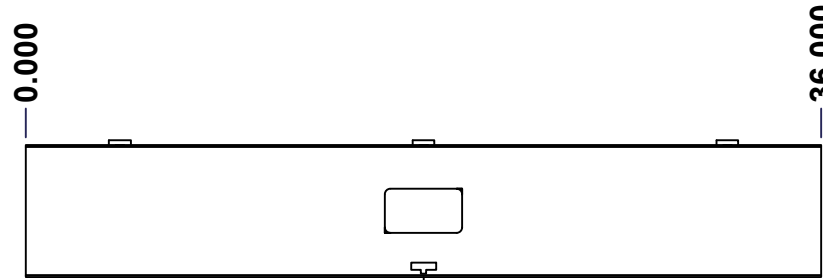

FRONT

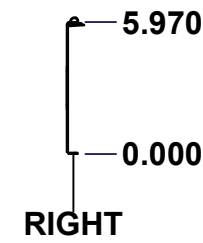

RIGHT

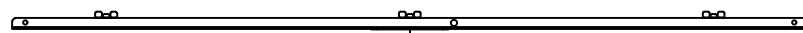

BOTTOM

No.	Revisions	Date	By/Par

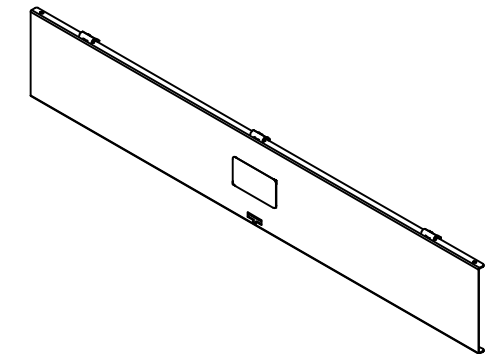

Isometric View



Tél: (450) 979-4373  
 Fax: (450) 979-4626  
[www.exmweb.com](http://www.exmweb.com)

Flatness  
Aplatissement

Max 3.0mm

Projection

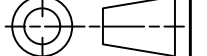

Customer Client	Date
Drawn By / Dessiné Par: BoxCad: BoxCad	Date: 04-Dec-23
Material / Matière: 16 Ga Cold Rolled A1008 CS Type B (1.4mm)	

Color / Couleur: Asa-61 Grey	Finish / Fini: Smooth
------------------------------	-----------------------

Description: 1100T 18" x 36" Cover	Detail Rev.
------------------------------------	-------------

Part Number / Numéro Pièce: 1100T3103C	Rev. 0	9 / 10
--	--------	--------

SEE BILL OF MATERIAL ON LAST PAGE

This drawing is confidential and must not be reproduced or used without the consent of EXM

Ce dessin est confidentiel et ne doit pas être reproduit ou utilisé sans le consentement de EXM

No.	Revisions	Date	By/Par

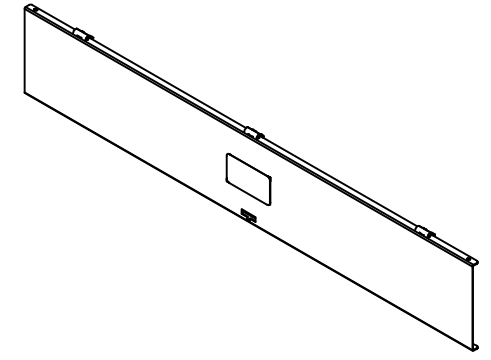

Isometric View



Tél: (450) 979-4373  
 Fax: (450) 979-4626  
[www.exmweb.com](http://www.exmweb.com)

Flatness  
Aplatissement  
Max 3.0mm  
Projection

Customer Client	Date
Drawn By / Dessiné Par: BoxCad: BoxCad	Date: 04-Dec-23
Material / Matière: 16 Ga Cold Rolled A1008 CS Type B (1.4mm)	

Color / Couleur: Asa-61 Grey	Finish / Fini: Smooth
------------------------------	-----------------------

Description: 1100T 18" x 36" Cover	Detail Rev.
------------------------------------	-------------

Part Number / Numéro Pièce: <b>1100T3103C</b>	Rev. 0	10 / 10
---	--------	---------

QTY	Part Number	Rev	Description
1	STK-P-02400S	0	Powder Paint (Asa-61 Grey / Smooth)
1	STK-S-00250	0	15.8mm x 44.45mm Silver Milar Sticker
1	STK-S-00100	0	3.5" x 2" Silver Milar Flexcon Sticker
3	STK-Q-33361	0	Spring Steel Hinge
1	1100T3103C-P	0	1100T 5.75" x 36" x 0" Cover Part
Parts List			