

This drawing is confidential and must not be reproduced or used without the consent of EXM

Ce dessin est confidentiel et ne doit pas être reproduit ou utilisé sans le consentement de EXM

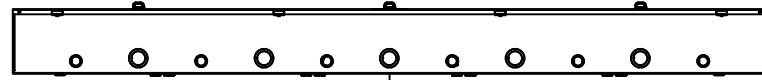

TOP



BACK

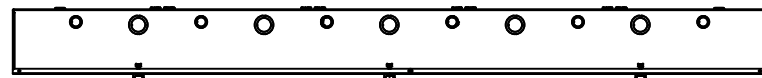

BOTTOM

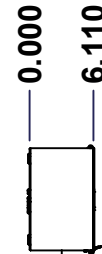

LEFT

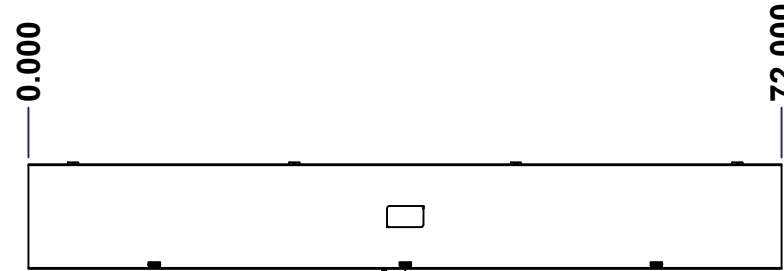

FRONT

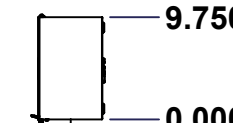

RIGHT

No.	Revisions	Date	By/Par

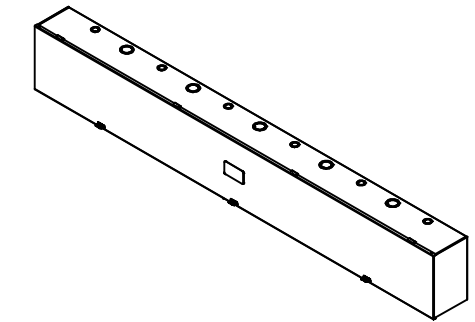

Isometric View

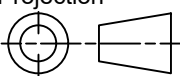

 Tél: (450) 979-4373 Fax: (450) 979-4626 www.exmweb.com	Flatness Aplatissement Max 3.0mm
	Projection 
Customer Client	Date
Drawn By Dessiné Par BoxCad: BoxCad	Date 11-Jul-24
Material Matière 16 Ga Cold Rolled A1008 CS Type B (1.4mm)	
Color Couleur Asa-61 Grey	Finish Fini Smooth
Description 1100T 9.75" x 72" x 6.11" Assembly	
Part Number Numéro Pièce 1100T6604	Detail Rev. Rev. 1 0

SEE BILL OF MATERIAL ON LAST PAGE

This drawing is confidential and must not be reproduced or used without the consent of EXM

Ce dessin est confidentiel et ne doit pas être reproduit ou utilisé sans le consentement de EXM

NOTE	
ITEM	DESCRIPTION
1	NEMA 1 Enclosure (IP20)
2	C/W Standard ground studs on box and cover
3	W/O Inner panel
4	W/O Inner panel mounting studs

No.	Revisions	Date	By/Par

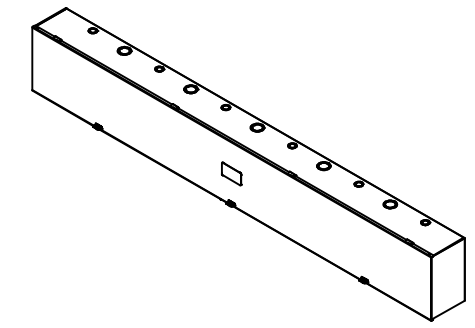
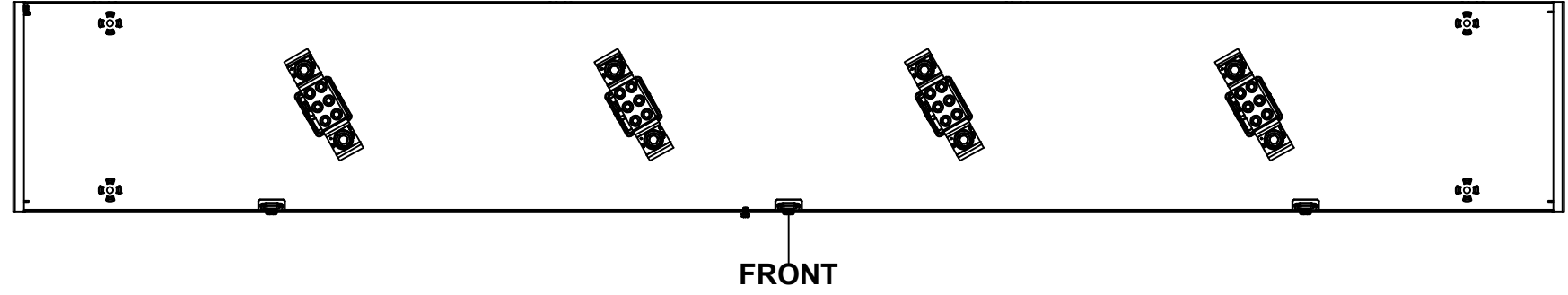

PACKING		
ITEM	QTY	DESCRIPTION
Cardboard sleeve	2	Top and Bottom
Cardboard strip	2	Between back of enclosure and inner panel
Plastic bag	1	To protect cover surface and inside gasket
Cardboard corner	4	To reinforced for the plastic strap tightening
Plastic strap - Black	2	To Squeeze the 2 cardboard sleeve together
Packaging label	3	White label with PN
Plastic strap- Green	2	To secure the enclosure to the wood pallet
Wood Pallet	1	2" deeper and 3" larger than enclosure size

Qty	Part Number	Rev	Description
3	STK-Q-77450	3	Plastic Padlock Provision
1	1100T6604C	0	1100T 18" x 72" Cover
1	STK-K-02700	0	1412 T Accessory Kit
1	1100T6604B	0	1100T 9.75" x 72" x 6.11" Body
4	881 BRC600	7	Aluminum Lug with Insulator (250MCM-2)

Parts List

Tél: (450) 979-4373
Fax: (450) 979-4626
www.exmweb.com

Flatness
Aplatissement
Max 3.0mm

Projection

Customer Client	Date
Drawn By Dessiné Par BoxCad: BoxCad	Date 11-Jul-24
Material Matière 16 Ga Cold Rolled A1008 CS Type B (1.4mm)	
Color Couleur Asa-61 Grey	Finish Fini Smooth
Description 1100T 9.75" x 72" x 6.11" Assembly	Detail Rev.
Part Number Numéro Pièce 1100T6604	Rev. 0 / 2

This drawing is confidential and must not be reproduced or used without the consent of EXM

Ce dessin est confidentiel et ne doit pas être reproduit ou utilisé sans le consentement de EXM

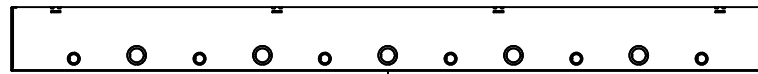

TOP

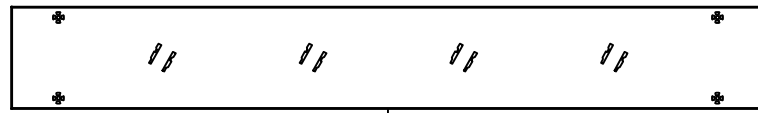

BACK

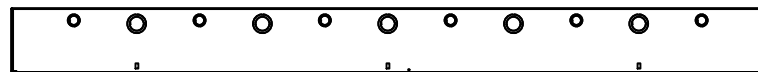

BOTTOM

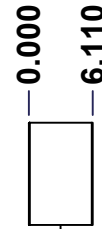

LEFT

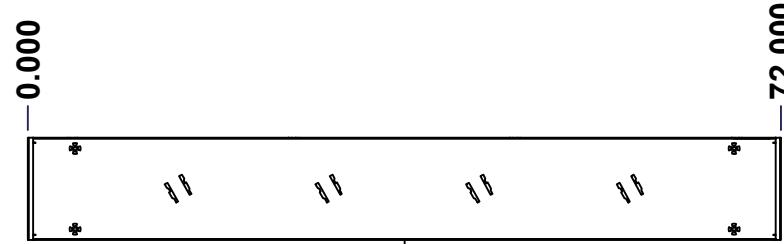

FRONT

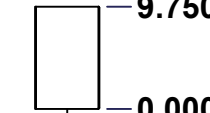

RIGHT

No.	Revisions	Date	By/Par

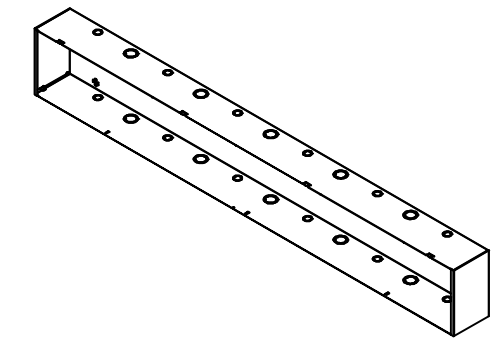

Isometric View

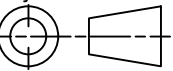

 Tél: (450) 979-4373 Fax: (450) 979-4626 www.exmweb.com	Flatness Aplatissement Max 3.0mm
	Projection 
Customer Client	Date
Drawn By Dessiné Par BoxCad: BoxCad	Date 11-Jul-24
Material Matière 16 Ga Cold Rolled A1008 CS Type B (1.4mm)	
Color Couleur Asa-61 Grey	Finish Fini Smooth
Description 1100T 9.75" x 72" x 6.11" Body	
Part Number Numéro Pièce 1100T6604B	Detail Rev. Rev. 3 0

SEE BILL OF MATERIAL ON LAST PAGE

This drawing is confidential and must not be reproduced or used without the consent of EXM

Ce dessin est confidentiel et ne doit pas être reproduit ou utilisé sans le consentement de EXM

STANDARD FEATURES ARE NOT LISTED IN THIS HOLE TABLE

HOLE TABLE - TOP VIEW (CUSTOM FEATURE ONLY)

CUT-OUT	XDIM	YDIM	DESCRIPTION
1	42.000	1.188	DKO Ø1.125 - 0.875
2	36.000	1.500	DKO Ø1.750 - 1.375
3	30.000	1.188	DKO Ø1.125 - 0.875
4	24.000	1.500	DKO Ø1.750 - 1.375
5	48.000	1.500	DKO Ø1.750 - 1.375
6	54.000	1.188	DKO Ø1.125 - 0.875
7	18.000	1.188	DKO Ø1.125 - 0.875
8	12.000	1.500	DKO Ø1.750 - 1.375
9	6.000	1.188	DKO Ø1.125 - 0.875
10	66.000	1.188	DKO Ø1.125 - 0.875
11	60.000	1.500	DKO Ø1.750 - 1.375

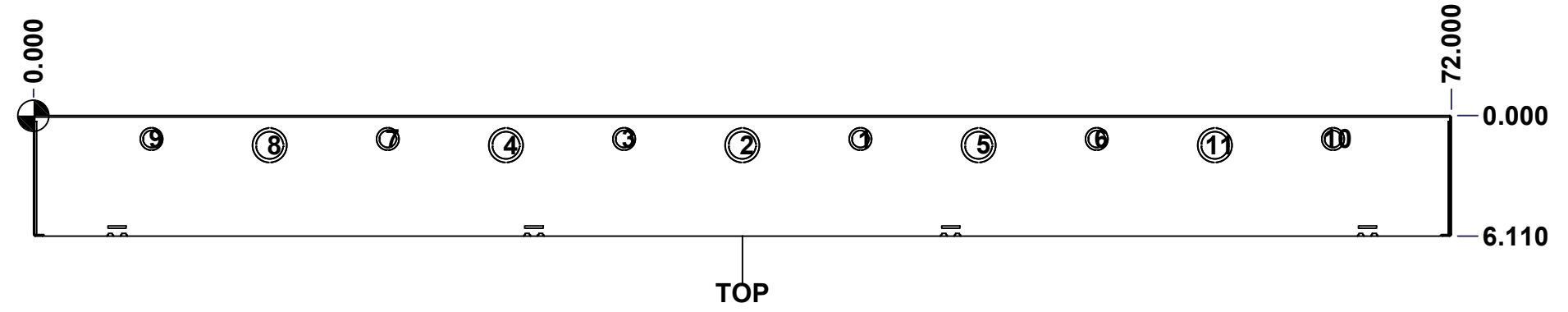

	Description	Status	
	1100T 9.75" x 72" x 6.11" Body	(NULL)	
	Part Number Numéro Pièce	Rev.	
	1100T6604B	0	4 / 8

This drawing is confidential and must not be reproduced or used without the consent of EXM

Ce dessin est confidentiel et ne doit pas être reproduit ou utilisé sans le consentement de EXM

STANDARD FEATURES ARE NOT LISTED IN THIS HOLE TABLE

HOLE TABLE - BOTTOM VIEW (CUSTOM FEATURE ONLY)

CUT-OUT	XDIM	YDIM	DESCRIPTION
1	42.000	1.188	DKO Ø1.125 - 0.875
2	36.000	1.500	DKO Ø1.750 - 1.375
3	30.000	1.188	DKO Ø1.125 - 0.875
4	24.000	1.500	DKO Ø1.750 - 1.375
5	18.000	1.188	DKO Ø1.125 - 0.875
6	54.000	1.188	DKO Ø1.125 - 0.875
7	48.000	1.500	DKO Ø1.750 - 1.375
8	12.000	1.500	DKO Ø1.750 - 1.375
9	6.000	1.188	DKO Ø1.125 - 0.875
10	66.000	1.188	DKO Ø1.125 - 0.875
11	60.000	1.500	DKO Ø1.750 - 1.375

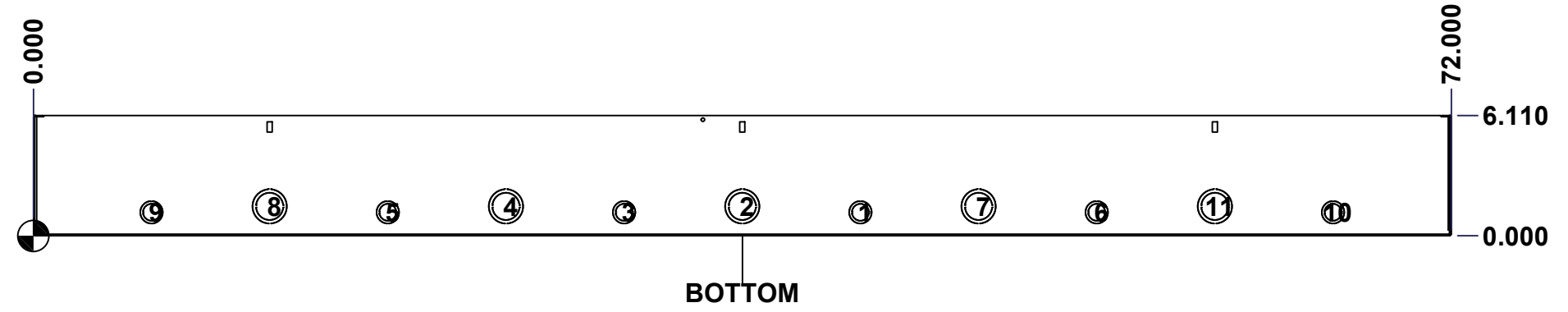

	Description	Status	
	1100T 9.75" x 72" x 6.11" Body	(NULL)	
	Part Number Numéro Pièce	Rev.	
	1100T6604B	0	5 8

This drawing is confidential and must not be reproduced or used without the consent of EXM

Ce dessin est confidentiel et ne doit pas être reproduit ou utilisé sans le consentement de EXM

No.	Revisions	Date	By/Par

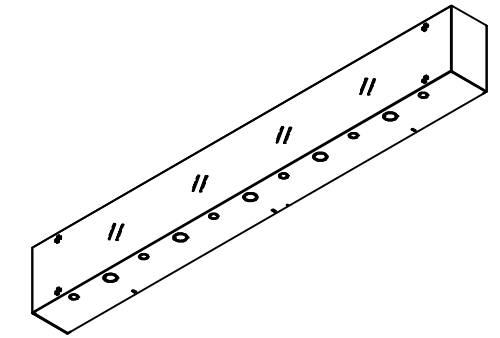

Isometric View

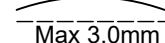

 Tél: (450) 979-4373 Fax: (450) 979-4626 www.exmweb.com		Flatness Aplatissement  Max 3.0mm
Customer Client		Date
Drawn By / Dessiné Par: BoxCad: BoxCad		Date: 11-Jul-24
Material / Matière: 16 Ga Cold Rolled A1008 CS Type B (1.4mm)		
Color / Couleur: Asa-61 Grey	Finish / Fini: Smooth	
Description: 1100T 9.75" x 72" x 6.11" Body		Detail Rev.
Part Number / Numéro Pièce: 1100T6604B		Rev. 6 / 8

Qty	Part Number	Rev	Description
1	STK-P-02400S	0	Powder Paint (Asa-61 Grey / Smooth)
1	STK-S-00100	0	3.5" x 2" Silver Milar Flexcon Sticker
1	1100T6604B-P	0	1100T 9.75" x 72" x 6.11" Body Part
Parts List			

This drawing is confidential and must not be reproduced or used without the consent of EXM

Ce dessin est confidentiel et ne doit pas être reproduit ou utilisé sans le consentement de EXM

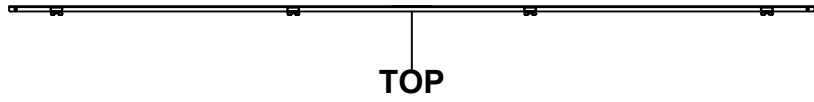

TOP

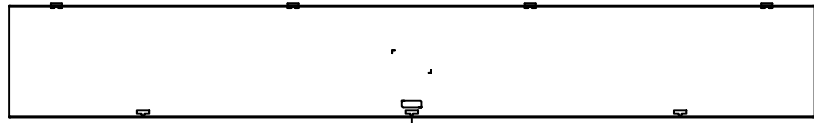

BACK

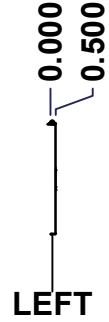

LEFT

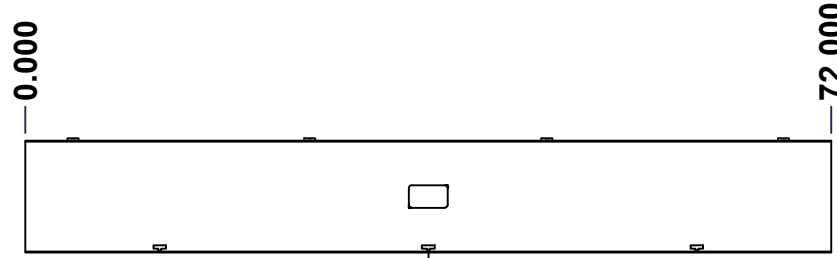

FRONT

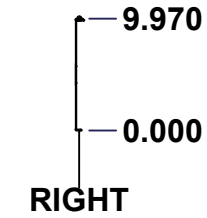

RIGHT



BOTTOM

No.	Revisions	Date	By/Par

Isometric View

Tél: (450) 979-4373 Fax: (450) 979-4626 www.exmweb.com		Flatness Aplatissement
		Max 3.0mm
Projection 		
Customer Client		Date
Drawn By Dessiné Par	BoxCad: BoxCad	Date 11-Jul-24
Material Matière	16 Ga Cold Rolled A1008 CS Type B (1.4mm)	
Color Couleur	Asa-61 Grey	Finish Fini Smooth
Description	Detail Rev.	
1100T 18" x 72" Cover		
Part Number Numéro Pièce	Rev. 0	7/8
1100T6604C		

SEE BILL OF MATERIAL ON LAST PAGE

This drawing is confidential and must not be reproduced or used without the consent of EXM

Ce dessin est confidentiel et ne doit pas être reproduit ou utilisé sans le consentement de EXM

No.	Revisions	Date	By/Par

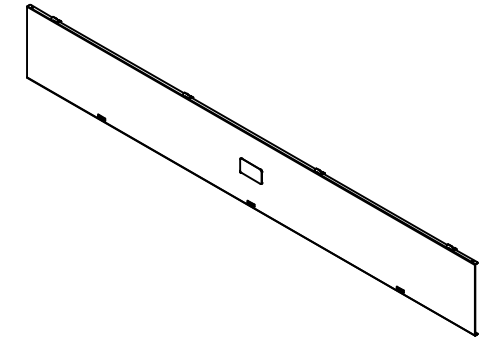

Isometric View



Tél: (450) 979-4373
 Fax: (450) 979-4626
www.exmweb.com

Flatness
Aplatissement
Max 3.0mm
Projection

Customer Client	Date
Drawn By / Dessiné Par: BoxCad: BoxCad	Date: 11-Jul-24
Material / Matière: 16 Ga Cold Rolled A1008 CS Type B (1.4mm)	

Color / Couleur: Asa-61 Grey	Finish / Fini: Smooth
------------------------------	-----------------------

Description: 1100T 18" x 72" Cover	Detail Rev.
------------------------------------	-------------

Part Number / Numéro Pièce: 1100T6604C	Rev. 0	8
---	--------	---

QTY	Part Number	Rev	Description
1	STK-P-02400S	0	Powder Paint (Asa-61 Grey / Smooth)
1	STK-S-00250	0	15.8mm x 44.45mm Silver Milar Sticker
1	STK-S-00100	0	3.5" x 2" Silver Milar Flexcon Sticker
4	STK-Q-33361	0	Spring Steel Hinge
1	1100T6604C-P	0	1100T 9.75" x 72" x 0" Cover Part
Parts List			