

This drawing is confidential and must not be reproduced or used without the consent of EXM

Ce dessin est confidentiel et ne doit pas être reproduit ou utilisé sans le consentement de EXM

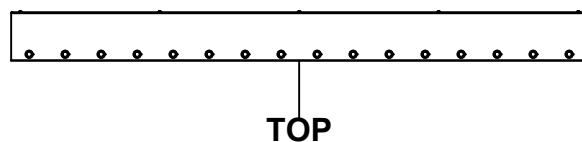

TOP

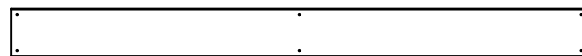

BACK

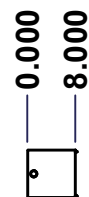

LEFT



FRONT



RIGHT

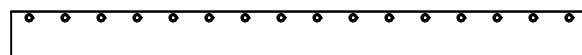

BOTTOM

| No. | Revisions | Date | By/Par |
|-----|-----------|------|--------|
|     |           |      |        |
|     |           |      |        |
|     |           |      |        |
|     |           |      |        |
|     |           |      |        |

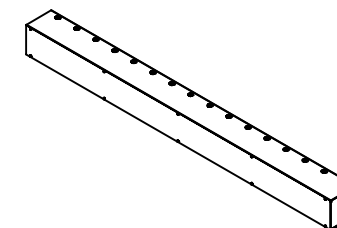

Isometric View



Tél: (450) 979-4373  
 Fax: (450) 979-4626  
[www.exmweb.com](http://www.exmweb.com)

Flatness  
Aplatissement

Max 3.0mm

Projection



|   |                       |
|---|-----------------------|
| Customer Client   | Date                  |
| Drawn By<br>Dessiné Par BoxCad: BoxCad                        | Date 26-Mar-15        |
| Material<br>Matière 16 Ga Cold Rolled A1008 CS Type B (1.4mm) |                       |
| Color<br>Couleur Asa-61 Grey                                  | Finish<br>Fini Smooth |
| Description<br>1100WD 8" x 8" x 96" Assembly                  | Detail Rev.           |
| Part Number<br>Numéro Pièce <b>1100WD080896</b>               | Rev. <b>0</b>         |

SEE BILL OF MATERIAL ON LAST PAGE

1  
7

This drawing is confidential and must not be reproduced or used without the consent of EXM

Ce dessin est confidentiel et ne doit pas être reproduit ou utilisé sans le consentement de EXM

| NOTE |  |
|------|--|
| ITEM | DESCRIPTION                                    |
| 1    | NEMA 1 Enclosure (IP20)                        |
| 2    | C/W Standard ground provision on box and cover |
| 3    | W/O Standard door stiffener                    |
| 4    | W/O Inner panel                                |
| 5    | W/O Inner panel mounting provision             |

| No. | Revisions | Date | By/Par |
|-----|-----------|------|--------|
|     |           |      |        |
|     |           |      |        |
|     |           |      |        |
|     |           |      |        |
|     |           |      |        |

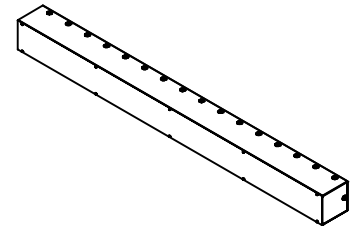

Isometric View



Tél: (450) 979-4373  
 Fax: (450) 979-4626  
[www.exmweb.com](http://www.exmweb.com)



|   |                       |
|---|-----------------------|
| Customer Client   | Date                  |
| Drawn By / Dessiné Par: BoxCad: BoxCad                        | Date: 26-Mar-15       |
| Material / Matière: 16 Ga Cold Rolled A1008 CS Type B (1.4mm) |                       |
| Color / Couleur: Asa-61 Grey                                  | Finish / Fini: Smooth |

| PACKING              |     |   |
|----------------------|-----|---|
| ITEM                 | QTY | DESCRIPTION                             |
| Thermal plastic film | 1   | Use with Packing Tunnel Wrapper Machine |
| Packaging label      | 1   | White label with product number         |

| Qty | Part Number   | Rev | Description                   |
|-----|---------------|-----|-------------------------------|
| 10  | STK-Q-05020   | 5   | M5 x 8mm Thread Rolling Screw |
| 1   | 1100WD080896C | 0   | 1100WD 8" x 96" Cover         |
| 1   | 1100WD080896B | 0   | 1100WD 8" x 8" x 96" Body     |

Parts List

|   |                       |
|---|-----------------------|
| Description: 1100WD 8" x 8" x 96" Assembly      | Detail Rev.           |
| Part Number / Numéro Pièce: <b>1100WD080896</b> | Rev. <b>0</b> / 2 / 7 |

This drawing is confidential and must not be reproduced or used without the consent of EXM

Ce dessin est confidentiel et ne doit pas être reproduit ou utilisé sans le consentement de EXM

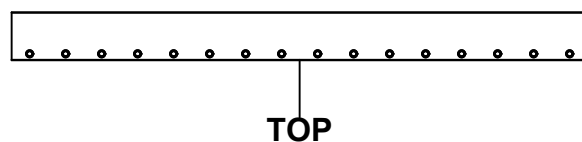

TOP

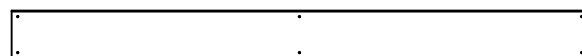

BACK

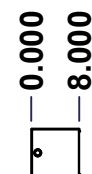

LEFT



FRONT

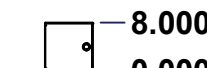

RIGHT

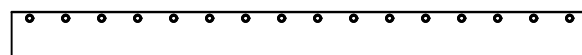

BOTTOM

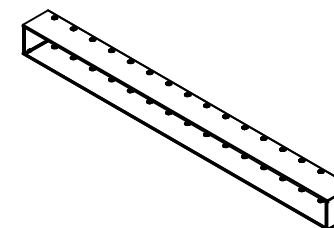

Isometric View

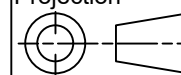

| No. | Revisions | Date | By/Par |
|-----|-----------|------|--------|
|     |           |      |        |
|     |           |      |        |
|     |           |      |        |
|     |           |      |        |

|  |                       |   |
|--|-----------------------|---|
|  Tél: (450) 979-4373<br>Fax: (450) 979-4626<br><a href="http://www.exmweb.com">www.exmweb.com</a> |                       | Flatness<br>Aplatissement<br>Max 3.0mm  |
| Customer Client  |                       | Projection<br> |
| Drawn By / Dessiné Par: BoxCad: BoxCad   |                       | Date: 26-Mar-15   |
| Material / Matière: 16 Ga Cold Rolled A1008 CS Type B (1.4mm)  |                       |   |
| Color / Couleur: Asa-61 Grey   | Finish / Fini: Smooth |   |
| Description: 1100WD 8" x 8" x 96" Body   |                       | Detail Rev.   |
| Part Number / Numéro Pièce: <b>1100WD080896B</b>   |                       | Rev. 0 / 3 / 7  |

SEE BILL OF MATERIAL ON LAST PAGE

This drawing is confidential and must not be reproduced or used without the consent of EXM

Ce dessin est confidentiel et ne doit pas être reproduit ou utilisé sans le consentement de EXM

| STANDARD FEATURES ARE NOT LISTED IN THIS HOLE TABLE |        |       |             |
|---|--------|-------|-------------|
| HOLE TABLE - BACK VIEW (CUSTOM FEATURE ONLY)        |        |       |             |
| CUT-OUT   | XDIM   | YDIM  | DESCRIPTION |
| 1   | 48.000 | 7.000 | RND Ø0.290  |
| 2   | 48.000 | 1.000 | RND Ø0.290  |
| 3   | 95.000 | 1.000 | RND Ø0.290  |
| 4   | 95.000 | 7.000 | RND Ø0.290  |
| 5   | 1.000  | 7.000 | RND Ø0.290  |
| 6   | 1.000  | 1.000 | RND Ø0.290  |

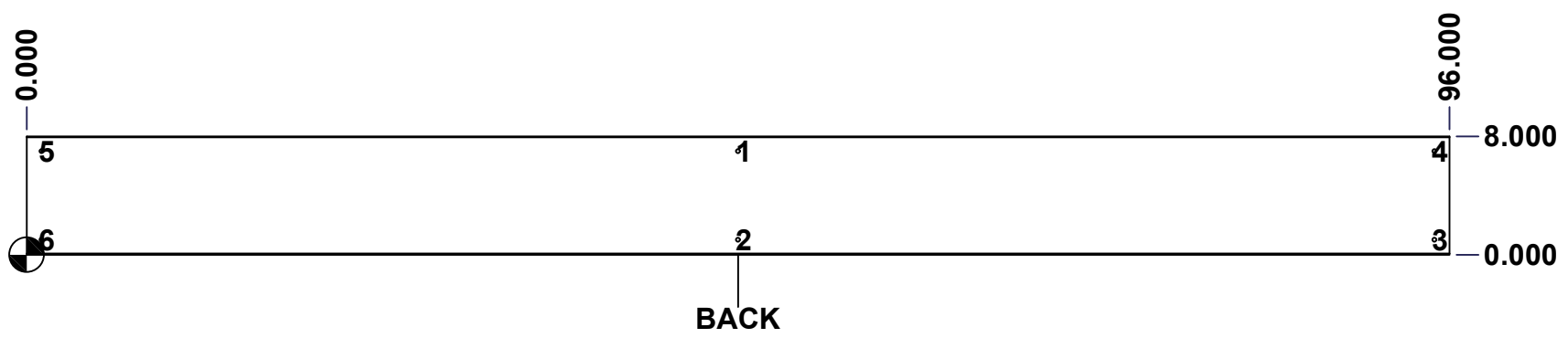

|  |                             |          |       |
|--|-----------------------------|----------|-------|
|  | Description                 | Status   |       |
|  | 1100WD 8" x 8" x 96" Body   | (NULL)   |       |
|  | Part Number<br>Numéro Pièce | Rev.     |       |
|  | <b>1100WD080896B</b>        | <b>0</b> | 4 / 7 |

This drawing is confidential and must not be reproduced or used without the consent of EXM

Ce dessin est confidentiel et ne doit pas être reproduit ou utilisé sans le consentement de EXM

| No. | Revisions | Date | By/Par |
|-----|-----------|------|--------|
|     |           |      |        |
|     |           |      |        |
|     |           |      |        |
|     |           |      |        |
|     |           |      |        |

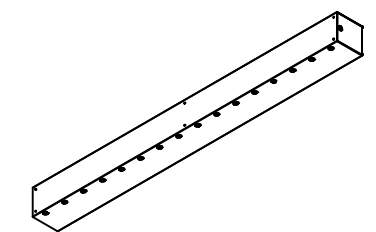

Isometric View

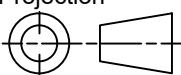

|  |   |   |
|--|---|---|
|  Tél: (450) 979-4373<br>Fax: (450) 979-4626<br><a href="http://www.exmweb.com">www.exmweb.com</a> | Flatness<br>Aplatissement                 | Max 3.0mm   |
|  | Projection                                |  |
| Customer<br>Client   | Date                                      |   |
| Drawn By<br>Dessiné Par  | BoxCad: BoxCad                            | Date 26-Mar-15  |
| Material<br>Matière  | 16 Ga Cold Rolled A1008 CS Type B (1.4mm) |   |
| Color<br>Couleur   | Asa-61 Grey                               | Finish<br>Fini Smooth   |
| Description  | Detail Rev.                               |   |
| 1100WD 8" x 8" x 96" Body  |   |   |
| Part Number<br>Numéro Pièce  | Rev.                                      | 5   |
| <b>1100WD080896B</b>   | <b>0</b>                                  | 7   |

| Qty        | Part Number     | Rev | Description                         |
|------------|-----------------|-----|-------------------------------------|
| 1          | STK-P-02400S    | 0   | Powder Paint (Asa-61 Grey / Smooth) |
| 1          | 1100WD080896R-P | 0   | 1100WD 8" x 8" Right Part           |
| 1          | 1100WD080896L-P | 0   | 1100WD 8" x 8" Left Part            |
| 1          | 1100WD080896B-P | 0   | 1100WD 8" x 8" x 96" Body Part      |
| Parts List |                 |     |                                     |

This drawing is confidential and must not be reproduced or used without the consent of EXM

Ce dessin est confidentiel et ne doit pas être reproduit ou utilisé sans le consentement de EXM

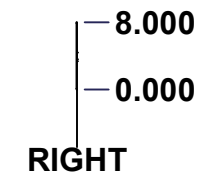
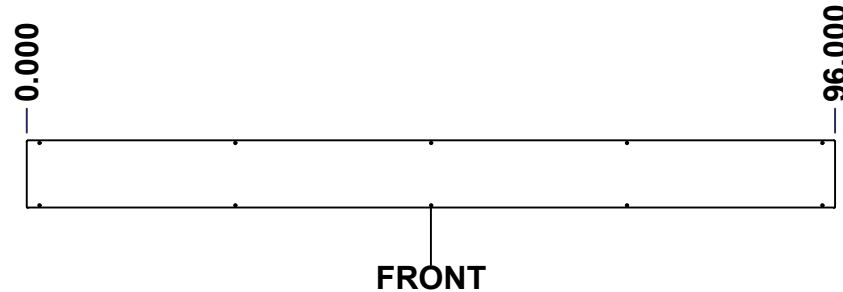
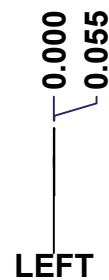
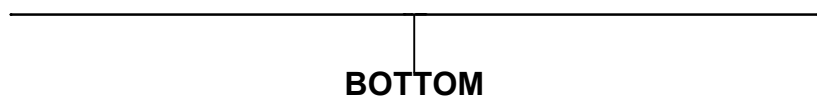
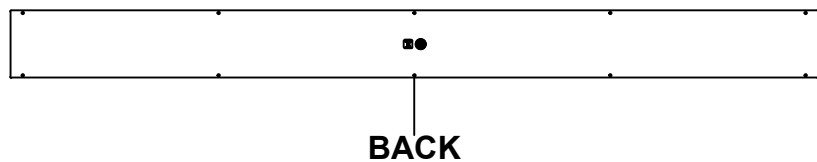
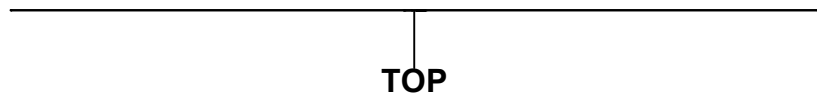

| No. | Revisions | Date | By/Par |
|-----|-----------|------|--------|
|     |           |      |        |
|     |           |      |        |
|     |           |      |        |
|     |           |      |        |

**Isometric View**

|  |                       |  |
|--|-----------------------|--|
| Tél: (450) 979-4373<br>Fax: (450) 979-4626<br><a href="http://www.exmweb.com">www.exmweb.com</a> |                       | Flatness<br>Aplatissement<br>Max 3.0mm<br>Projection<br> |
| Customer Client  | Date                  |  |
| Drawn By / Dessiné Par: BoxCad: BoxCad   | Date: 26-Mar-15       |  |
| Material / Matière: 16 Ga Cold Rolled A1008 CS Type B (1.4mm)                                    |                       |  |
| Color / Couleur: Asa-61 Grey   | Finish / Fini: Smooth |  |
| Description: 1100WD 8" x 96" Cover   | Detail Rev.           |  |
| Part Number / Numéro Pièce: <b>1100WD080896C</b>   | Rev.:                 | 6 / 7  |

**SEE BILL OF MATERIAL ON LAST PAGE**

This drawing is confidential and must not be reproduced or used without the consent of EXM

Ce dessin est confidentiel et ne doit pas être reproduit ou utilisé sans le consentement de EXM

| No. | Revisions | Date | By/Par |
|-----|-----------|------|--------|
|     |           |      |        |
|     |           |      |        |
|     |           |      |        |
|     |           |      |        |
|     |           |      |        |

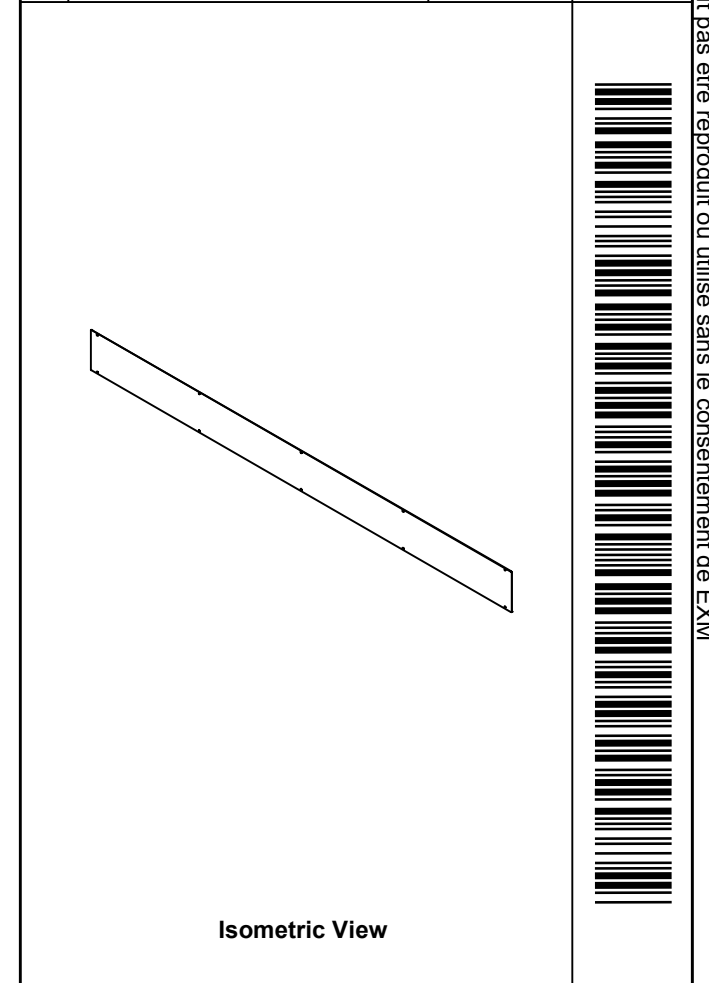

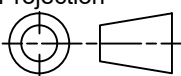
|  |   |   |
|--|---|---|
|  Tél: (450) 979-4373<br>Fax: (450) 979-4626<br><a href="http://www.exmweb.com">www.exmweb.com</a> |   | Flatness<br>Aplatissement<br>Max 3.0mm<br>Projection<br> |
| Customer Client  | Date                                      |   |
| Drawn By<br>Dessiné Par  | BoxCad: BoxCad                            | Date 26-Mar-15  |
| Material<br>Matière  | 16 Ga Cold Rolled A1008 CS Type B (1.4mm) |   |
| Color<br>Couleur   | Asa-61 Grey                               | Finish<br>Fini Smooth   |
| Description  |   | Detail Rev.   |
| 1100WD 8" x 96" Cover  |   |   |
| Part Number<br>Numéro Pièce  | Rev.                                      | 7   |
| <b>1100WD080896C</b>   | <b>0</b>                                  | 7   |

| QTY        | Part Number     | Rev | Description                         |
|------------|-----------------|-----|-------------------------------------|
| 1          | STK-S-00950     | 1   | UL 74SL Pull-Box Sticker            |
| 1          | STK-S-00800     | 2   | CSA Electrical Box Sticker          |
| 1          | STK-P-02400S    | 0   | Powder Paint (Asa-61 Grey / Smooth) |
| 1          | 1100WD080896C-P | 0   | 1100WD 8" x 96" Cover Part          |
| Parts List |                 |     |                                     |