

This drawing is confidential and must not be reproduced or used without the consent of EXM

Ce dessin est confidentiel et ne doit pas être reproduit ou utilisé sans le consentement de EXM

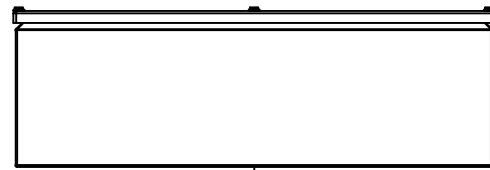

TOP

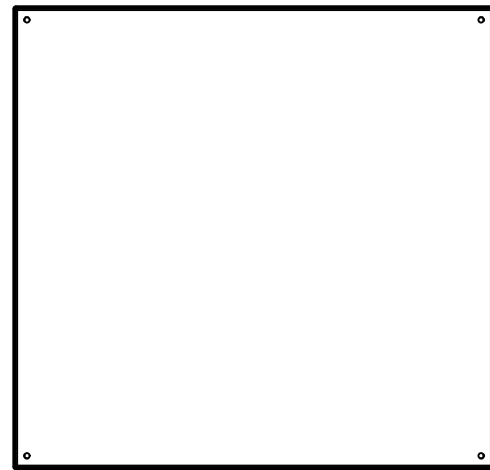

BACK



BOTTOM

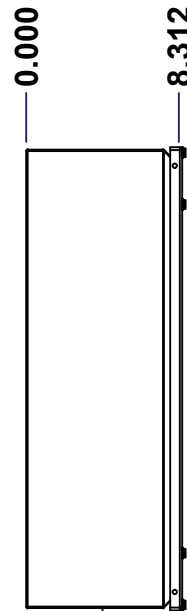

LEFT

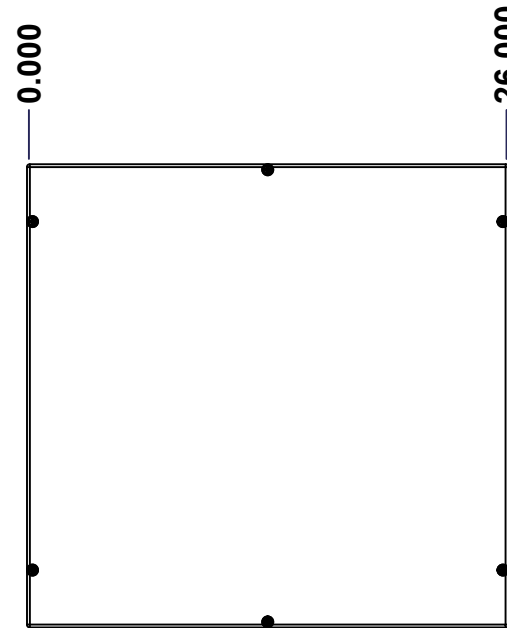

FRONT

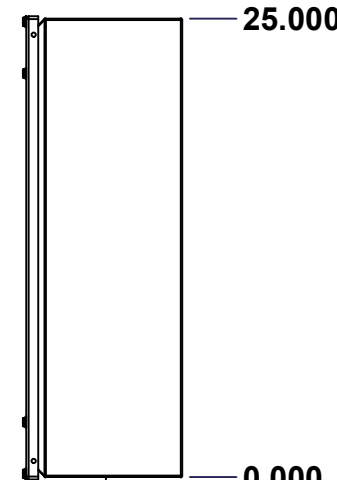

RIGHT

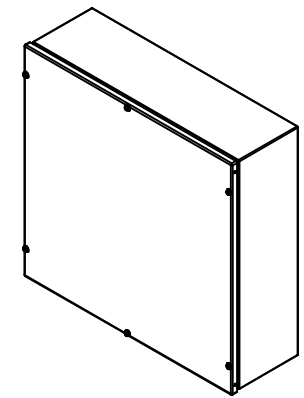

Isometric View

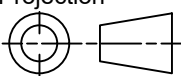

| No. | Revisions | Date | By/Par |
|-----|-----------|------|--------|
| | | | |
| | | | |
| | | | |
| | | | |
| | | | |

| | | |
|--|---|---|
|  Tél: (450) 979-4373 Fax: (450) 979-4626 www.exmweb.com | | Flatness Aplatissement Max 3.0mm Projection  |
| Customer Client | Date | |
| Drawn By Dessiné Par | BoxCad: BoxCad | Date 17-Jul-25 |
| Material Matière | 16 Ga Cold Rolled A1008 CS Type B (1.4mm) | |
| Color Couleur | Asa-61 Grey | Finish Fini Smooth |
| Description | Detail Rev. | |
| 1412B 25" x 26" x 8.312" Assembly | | |
| Part Number Numéro Pièce | Rev. 0 | 1 9 |
| SEE BILL OF MATERIAL ON LAST PAGE | | 1412B603 |

This drawing is confidential and must not be reproduced or used without the consent of EXM

Ce dessin est confidentiel et ne doit pas être reproduit ou utilisé sans le consentement de EXM

| NOTE | |
|------|--|
| ITEM | DESCRIPTION |
| 1 | NEMA 4, 12 Enclosure (IP66) |
| 2 | C/W Standard ground studs on box and cover |
| 3 | W/O Standard door stiffener |
| 4 | C/W Special inner panel (Sold separately) |
| 5 | C/W Standard inner panel mounting studs |

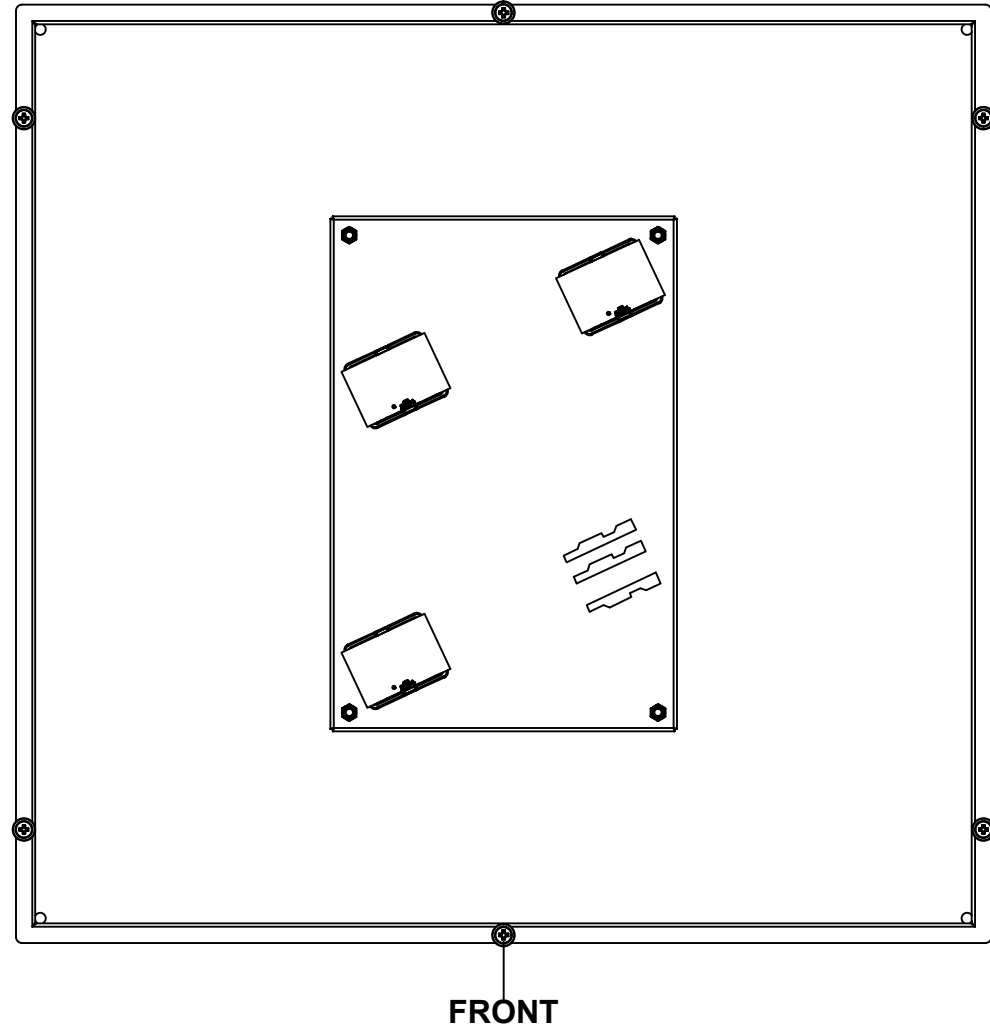

| No. | Revisions | Date | By/Par |
|-----|-----------|------|--------|
| | | | |
| | | | |
| | | | |
| | | | |
| | | | |

Isometric View

| PACKING | | |
|-----------------------|-----|--|
| ITEM | QTY | DESCRIPTION |
| Cardboard sleeve | 2 | Top and Bottom |
| Cardboard strip | 2 | Between back of enclosure and inner panel |
| Plastic bag | 1 | To protect cover surface and inside gasket |
| Cardboard corner | 4 | To reinforced for the plastic strap tightening |
| Plastic strap - Black | 2 | To Squeeze the 2 cardboard sleeve together |
| Packaging label | 3 | White label with PN |
| Plastic strap- Green | 2 | To secure the enclosure to the wood pallet |
| Wood Pallet | 1 | 2" deeper and 3" larger than enclosure size |

| | | | |
|------------|-------------|-----|-----------------------------|
| 1 | 1412B603C | 0 | 1412B 11" x 26" Cover |
| 1 | STK-K-02920 | 3 | 5412 ESSC Accessory Kit |
| 1 | 1412B603IP | 0 | 1412B 11" x 26" Inner Panel |
| 1 | 1412B603B | 0 | 1412B 25" x 26" x 8" Body |
| 3 | 881 BRB400 | 0 | Aluminum Lug with Insulator |
| 4 | STK-Q-07220 | 1 | M6 Nylon Insert Lock Nut |
| Qty | Part Number | Rev | Description |
| Parts List | | | |

Tél: (450) 979-4373
Fax: (450) 979-4626
www.exmweb.com

Flatness
Aplatissement
Max 3.0mm

Projection

| | |
|-----------------------------------|---|
| Customer Client | Date |
| Drawn By Dessiné Par | Date 17-Jul-25 |
| Material Matière | 16 Ga Cold Rolled A1008 CS Type B (1.4mm) |
| Color Couleur | Asa-61 Grey |
| Finish Fini | Smooth |
| Description | Detail Rev. |
| 1412B 25" x 26" x 8.312" Assembly | |
| Part Number Numéro Pièce | Rev. 2 |
| 1412B603 | 0 |

This drawing is confidential and must not be reproduced or used without the consent of EXM

Ce dessin est confidentiel et ne doit pas être reproduit ou utilisé sans le consentement de EXM

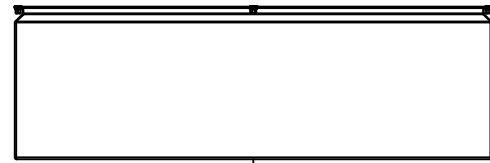

TOP

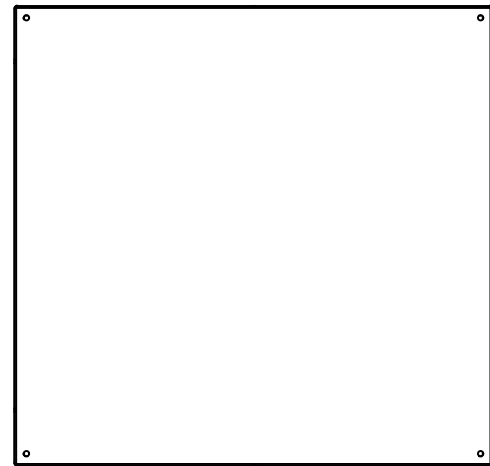

BACK



BOTTOM

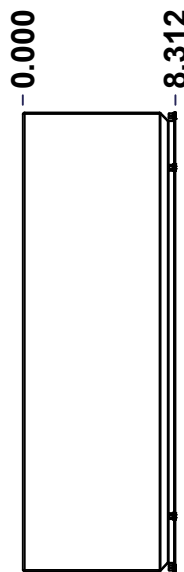

LEFT

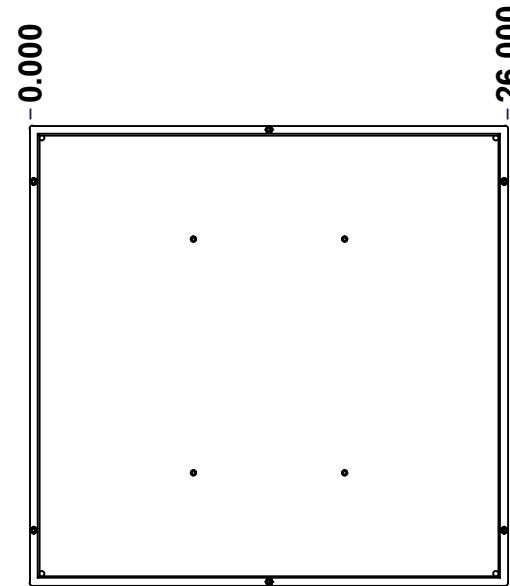

FRONT

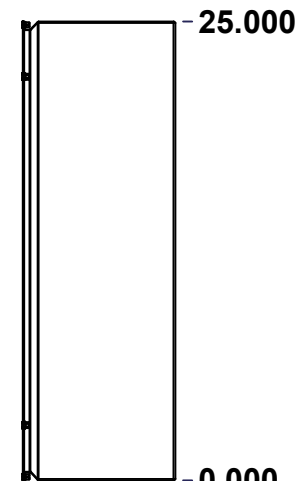

RIGHT

| No. | Revisions | Date | By/Par |
|-----|-----------|------|--------|
| | | | |
| | | | |
| | | | |
| | | | |
| | | | |

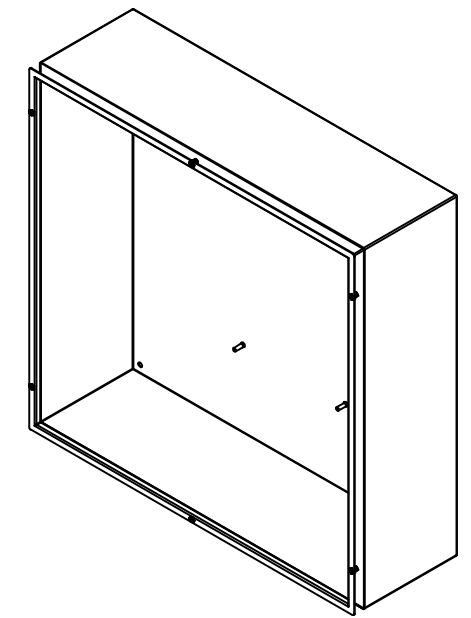

Isometric View



Tél: (450) 979-4373
 Fax: (450) 979-4626
www.exmweb.com

Flatness
Aplatissement

Max 3.0mm

Projection

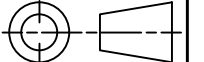

| | |
|---|-----------------------|
| Customer Client | Date |
| Drawn By / Dessiné Par: BoxCad: BoxCad | Date: 17-Jul-25 |
| Material / Matière: 16 Ga Cold Rolled A1008 CS Type B (1.4mm) | |
| Color / Couleur: Asa-61 Grey | Finish / Fini: Smooth |
| Description: 1412B 25" x 26" x 8" Body | Detail Rev. |
| Part Number / Numéro Pièce: 1412B603B | Rev. 0 |

SEE BILL OF MATERIAL ON LAST PAGE

This drawing is confidential and must not be reproduced or used without the consent of EXM

Ce dessin est confidentiel et ne doit pas être reproduit ou utilisé sans le consentement de EXM

STANDARD FEATURES ARE NOT LISTED IN THIS HOLE TABLE

HOLE TABLE - BACK VIEW (CUSTOM FEATURE ONLY)

| CUT-OUT | XDIM | YDIM | DESCRIPTION |
|---------|--------|--------|----------------------------|
| 1 | 8.875 | 18.875 | IP STUD M6 x 18mm (Inside) |
| 2 | 17.125 | 18.875 | IP STUD M6 x 18mm (Inside) |
| 3 | 8.875 | 6.125 | IP STUD M6 x 18mm (Inside) |
| 4 | 17.125 | 6.125 | IP STUD M6 x 18mm (Inside) |

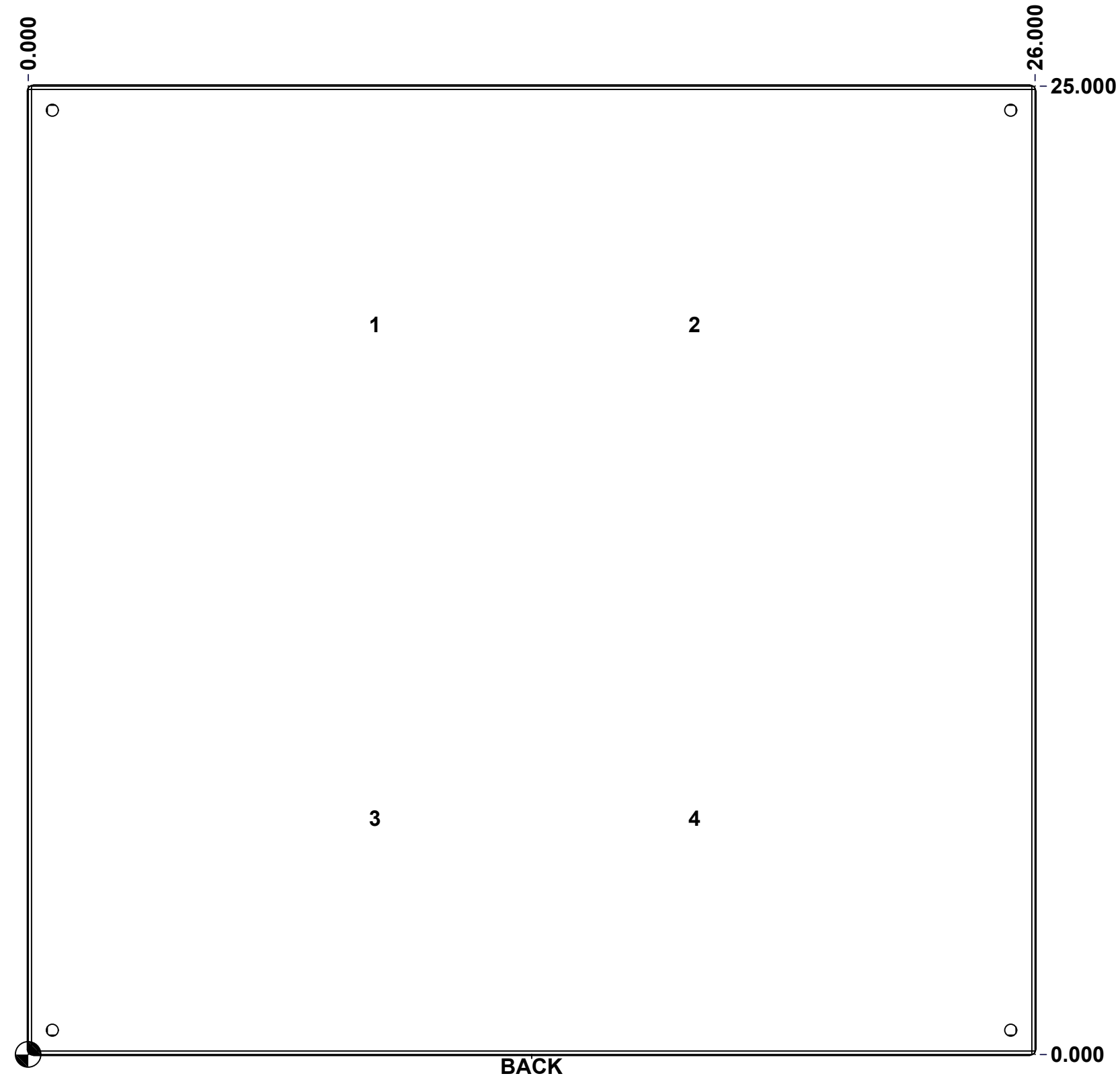

| | | | |
|--|-----------------------------|----------|--------|
| | Description | Status | |
| | 1412B 25" x 26" x 8" Body | (NULL) | |
| | Part Number Numéro Pièce | Rev. | |
| | 1412B603B | 0 | 4 9 |

This drawing is confidential and must not be reproduced or used without the consent of EXM

Ce dessin est confidentiel et ne doit pas être reproduit ou utilisé sans le consentement de EXM

| No. | Revisions | Date | By/Par |
|-----|-----------|------|--------|
| | | | |
| | | | |
| | | | |
| | | | |
| | | | |

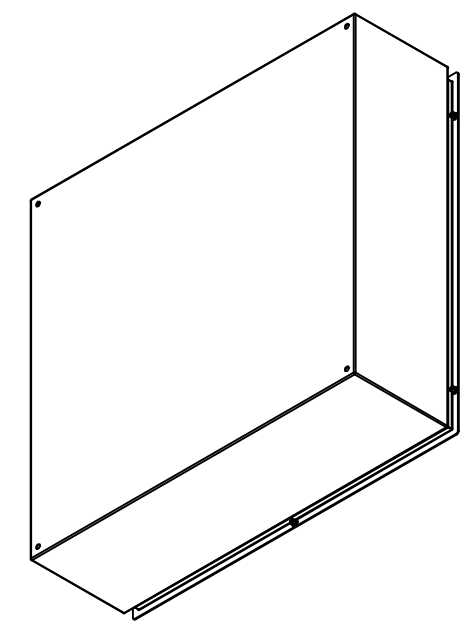

Isometric View

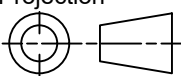
| | | |
|--|---|---|
|  Tél: (450) 979-4373 Fax: (450) 979-4626 www.exmweb.com | | Flatness Aplatissement Max 3.0mm Projection  |
| Customer Client | Date | |
| Drawn By Dessiné Par | BoxCad: BoxCad | Date 17-Jul-25 |
| Material Matière | 16 Ga Cold Rolled A1008 CS Type B (1.4mm) | |
| Color Couleur | Asa-61 Grey | Finish Fini Smooth |
| Description | | Detail Rev. |
| 1412B 25" x 26" x 8" Body | | |
| Part Number Numéro Pièce | Rev. | 5 |
| 1412B603B | 0 | 9 |

| Qty | Part Number | Rev | Description |
|------------|--------------------|-----|-------------------------------------|
| 4 | STK-Q-16050 | 1 | Stud M6 x 18mm Steel |
| 1 | 1412B603B-P | 0 | 1412B 25" x 26" x 8" Body Part |
| 1 | STK-P-02400S | 0 | Powder Paint (Asa-61 Grey / Smooth) |
| 6 | RIVET_NUT_M5_FH_OE | 0 | Rivet Nut M5 (Low Profile Open End) |
| Parts List | | | |

This drawing is confidential and must not be reproduced or used without the consent of EXM

Ce dessin est confidentiel et ne doit pas être reproduit ou utilisé sans le consentement de EXM

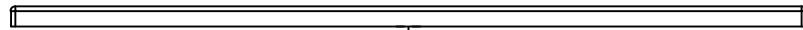

TOP

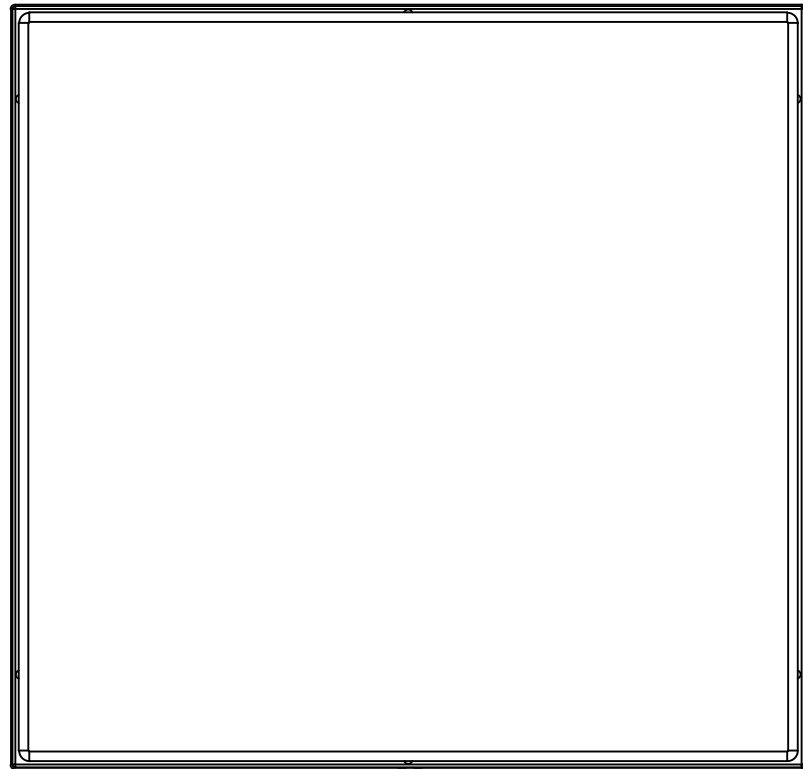

BACK

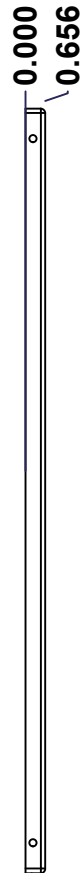

LEFT

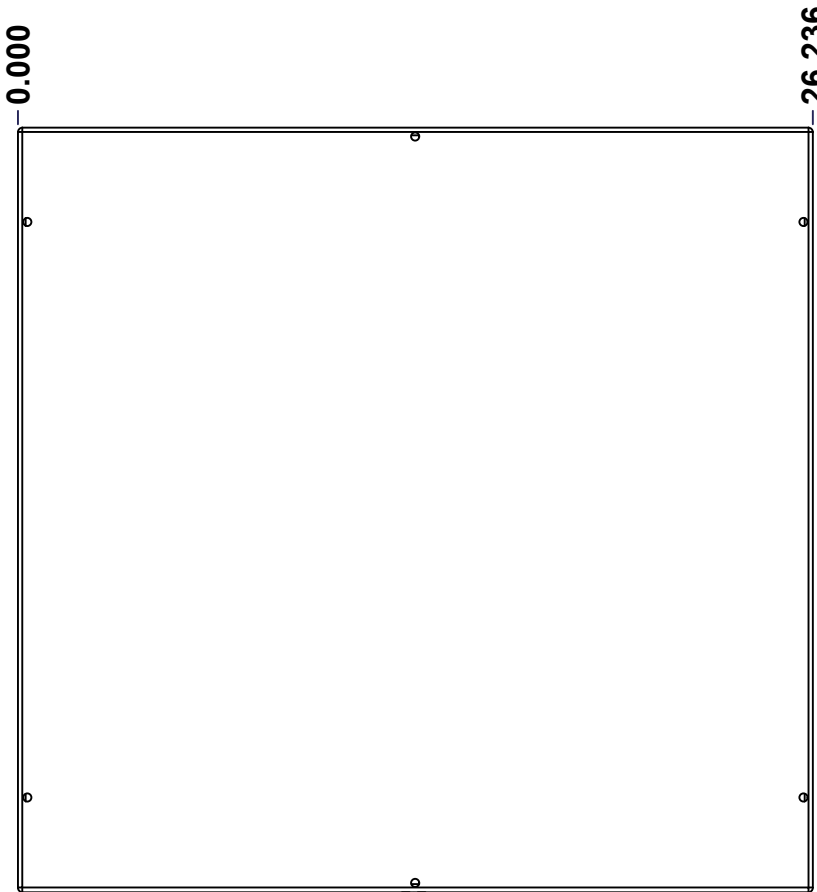

FRONT

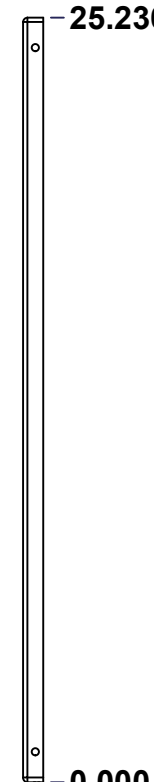

RIGHT

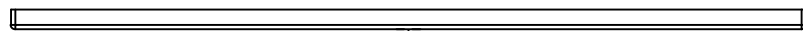

BOTTOM

| No. | Revisions | Date | By/Par |
|-----|-----------|------|--------|
| | | | |
| | | | |
| | | | |
| | | | |

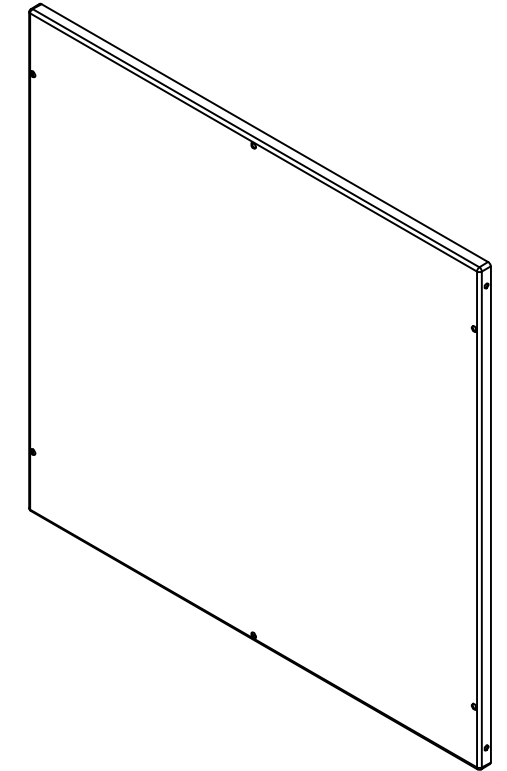

Isometric View



Tél: (450) 979-4373
 Fax: (450) 979-4626
www.exmweb.com

Flatness
Aplatissement

Max 3.0mm

Projection

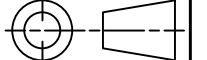

| | |
|---|-----------------|
| Customer Client | Date |
| Drawn By / Dessiné Par: BoxCad: BoxCad | Date: 17-Jul-25 |
| Material / Matière: 16 Ga Cold Rolled A1008 CS Type B (1.4mm) | |

| | |
|------------------------------|-----------------------|
| Color / Couleur: Asa-61 Grey | Finish / Fini: Smooth |
|------------------------------|-----------------------|

| | |
|------------------------------------|-------------|
| Description: 1412B 11" x 26" Cover | Detail Rev. |
|------------------------------------|-------------|

| | | |
|---------------------------------------|--------|-----|
| Part Number / Numéro Pièce: 1412B603C | Rev. 0 | 6/9 |
|---------------------------------------|--------|-----|

SEE BILL OF MATERIAL ON LAST PAGE

This drawing is confidential and must not be reproduced or used without the consent of EXM

Ce dessin est confidentiel et ne doit pas être reproduit ou utilisé sans le consentement de EXM

| No. | Revisions | Date | By/Par |
|-----|-----------|------|--------|
| | | | |
| | | | |
| | | | |
| | | | |
| | | | |

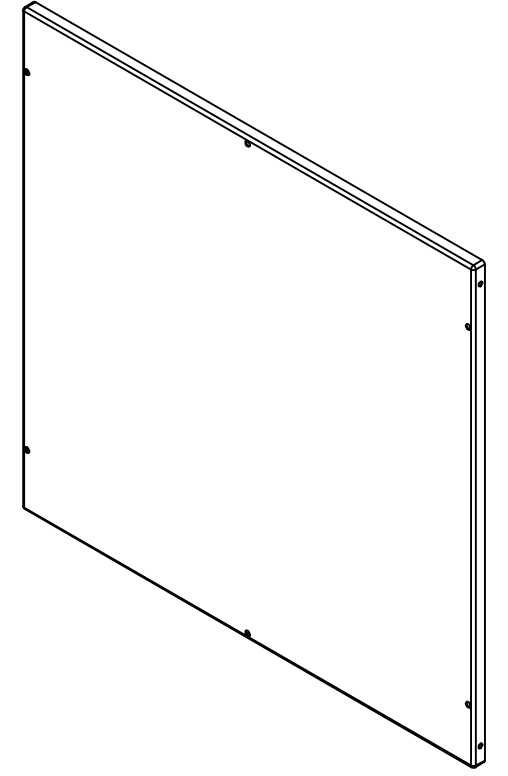

Isometric View



Tél: (450) 979-4373
 Fax: (450) 979-4626
www.exmweb.com

Flatness
Aplatissement
Max 3.0mm
Projection

| | |
|---|-----------------------|
| Customer Client | Date |
| Drawn By / Dessiné Par: BoxCad: BoxCad | Date: 17-Jul-25 |
| Material / Matière: 16 Ga Cold Rolled A1008 CS Type B (1.4mm) | |
| Color / Couleur: Asa-61 Grey | Finish / Fini: Smooth |

| Qty | Part Number | Rev | Description |
|------------|--------------|-----|-------------------------------------|
| 1 | STK-P-02400S | 0 | Powder Paint (Asa-61 Grey / Smooth) |
| 1 | 1412B603G | 0 | 1412B 25" x 26" Gasket |
| 1 | 1412B603C-P | 0 | 1412B 25" x 26" Cover Part |
| Parts List | | | |

| | |
|--|-------------|
| Description: 1412B 11" x 26" Cover | Detail Rev. |
| Part Number / Numéro Pièce: 1412B603C | Rev. 0 / 7 |

This drawing is confidential and must not be reproduced or used without the consent of EXM

Ce dessin est confidentiel et ne doit pas être reproduit ou utilisé sans le consentement de EXM

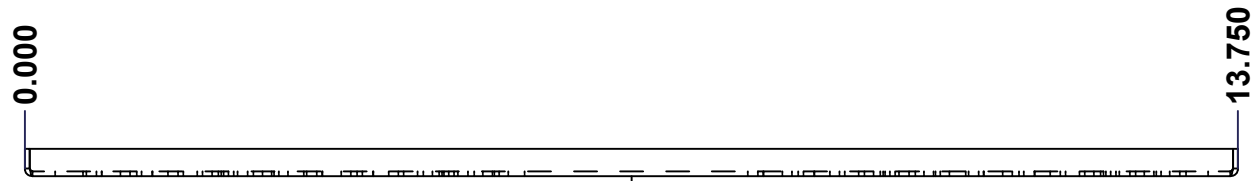

TOP

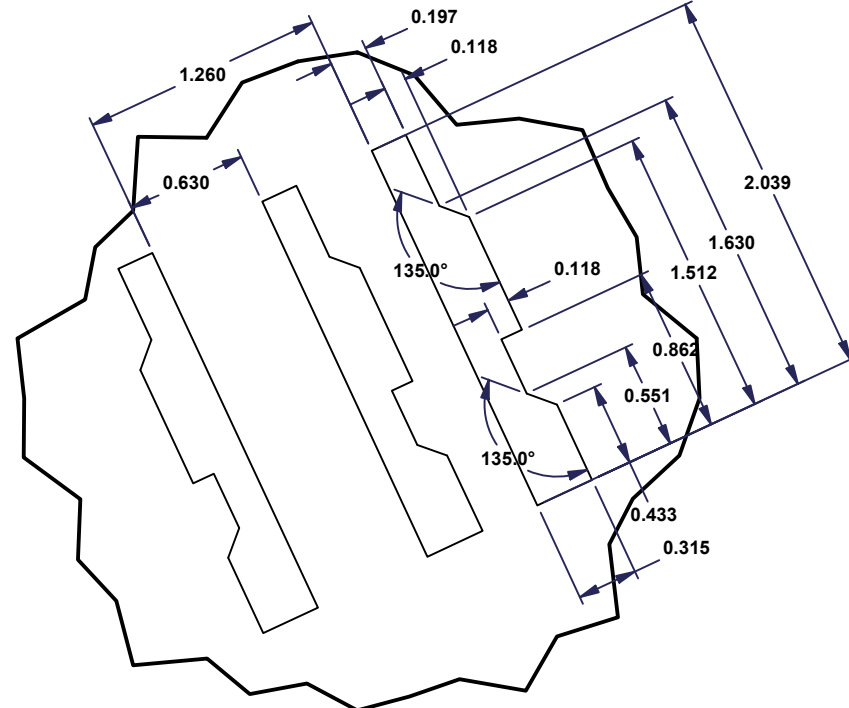

DETAIL A

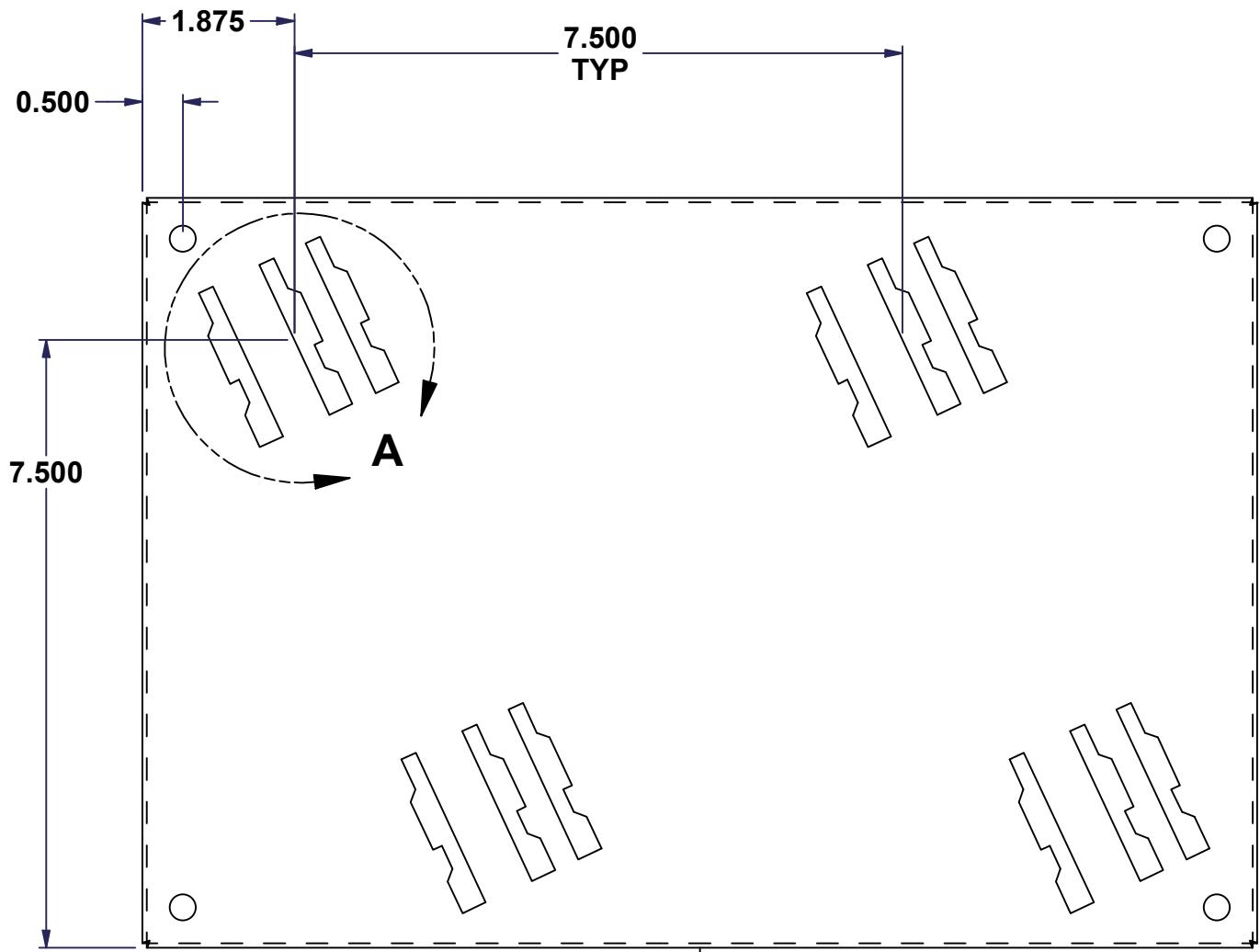

FRONT

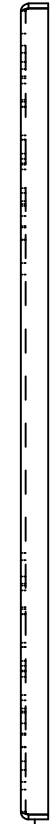

RIGHT

| No. | Revisions | Date | By/Par |
|-----|-----------|------|--------|
| | | | |
| | | | |
| | | | |
| | | | |

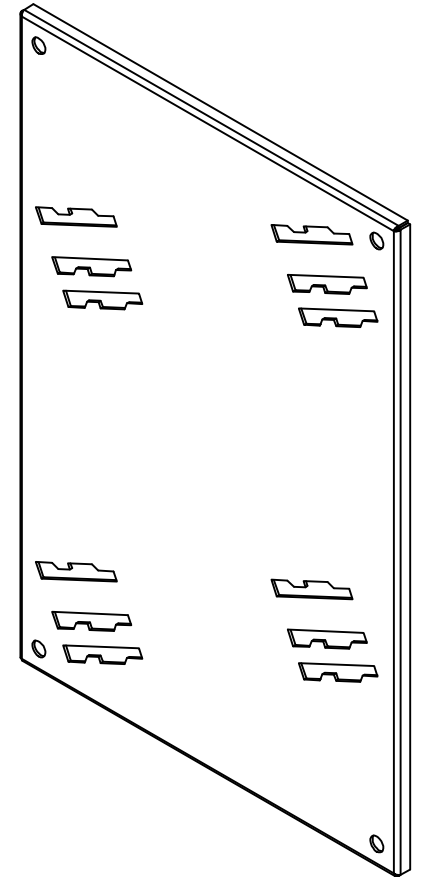

Isometric View



| | | |
|--|---------------------------|-----------------------|
| Tél: (450) 979-4373 Fax: (450) 979-4626 www.exmweb.com | Flatness Aplatissement | Max 3.0mm |
| | Projection | |
| Customer Client | Date | |
| Drawn By Dessiné Par | BoxCad: BoxCad | Date 17-Jul-25 |
| Material Matière | 16 Ga H.R.P. & O. (1.4mm) | |
| Color Couleur | White RAL9003 | Finish Fini Smooth |
| Description | Detail Rev. | |
| 1412B 11" x 26" Inner Panel | | |
| Part Number Numéro Pièce | Rev. | 8 |
| 1412B603IP | 0 | 9 |

SEE BILL OF MATERIAL ON LAST PAGE

This drawing is confidential and must not be reproduced or used without the consent of EXM

Ce dessin est confidentiel et ne doit pas être reproduit ou utilisé sans le consentement de EXM

| No. | Revisions | Date | By/Par |
|-----|-----------|------|--------|
| | | | |
| | | | |
| | | | |
| | | | |
| | | | |

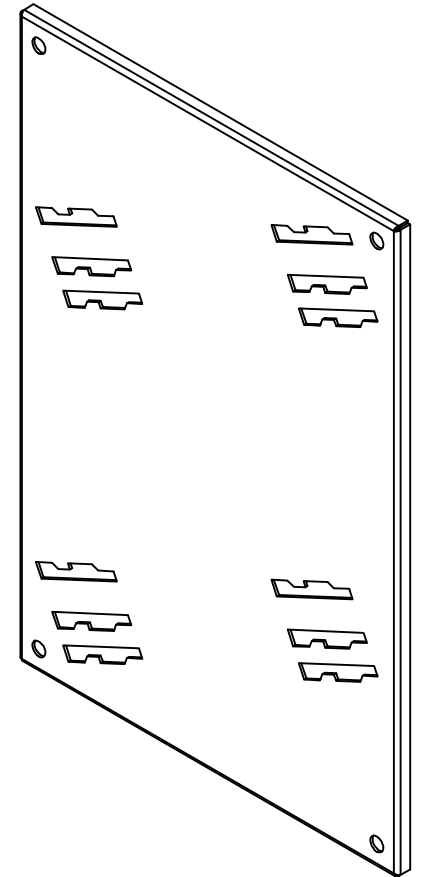

Isometric View



Tél: (450) 979-4373
 Fax: (450) 979-4626
www.exmweb.com

Flatness
Aplatissement
Max 3.0mm
Projection

| | |
|---|-----------------------|
| Customer Client | Date |
| Drawn By / Dessiné Par: BoxCad: BoxCad | Date: 17-Jul-25 |
| Material / Matière: 16 Ga H.R.P. & O. (1.4mm) | |
| Color / Couleur: White RAL9003 | Finish / Fini: Smooth |
| Description: 1412B 11" x 26" Inner Panel | Detail Rev. |
| Part Number / Numéro Pièce: 1412B603IP | Rev. 0 / 9 |

| Qty | Part Number | Rev | Description |
|------------|--------------|-----|----------------------------------|
| 1 | STK-P-02401S | 0 | Powder Paint (White / Smooth) |
| 1 | 1412B603IP-P | 0 | 1412B 26" x 26" Inner Panel Part |
| Parts List | | | |