

This drawing is confidential and must not be reproduced or used without the consent of EXM

Ce dessin est confidentiel et ne doit pas être reproduit ou utilisé sans le consentement de EXM

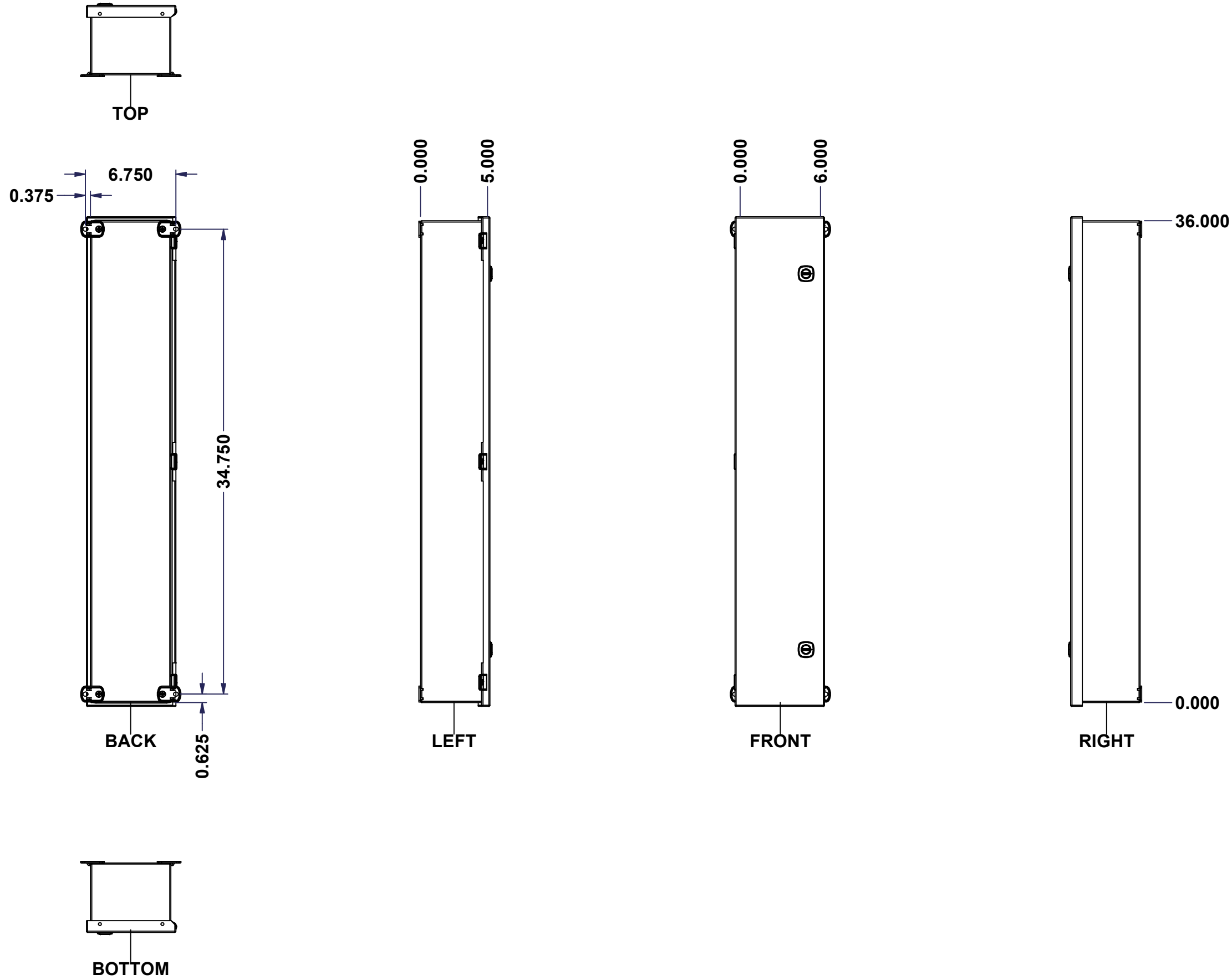

| No. | Revisions | Date | By/Par |
|-----|-----------|------|--------|
|     |           |      |        |
|     |           |      |        |
|     |           |      |        |
|     |           |      |        |
|     |           |      |        |

**Isometric View**

|  |   |  |
|--|---|--|
| Tél: (450) 979-4373<br>Fax: (450) 979-4626<br><a href="http://www.exmweb.com">www.exmweb.com</a> |   | Flatness<br>Aplatissement<br>Max 3.0mm<br>Projection<br> |
| Customer Client  | Date                                      |  |
| Drawn By<br>Dessiné Par  | BoxCad: BoxCad                            | Date 16-Jan-14   |
| Material<br>Matière  | 16 Ga Cold Rolled A1008 CS Type B (1.4mm) |  |
| Color<br>Couleur   | Asa-61 Grey                               | Finish<br>Fini Smooth                                    |
| Description  | Detail Rev.                               |  |
| 1412CH 36" x 6" x 5" Assembly  |   |  |
| Part Number<br>Numéro Pièce  | Rev. 0                                    | 1 / 8  |

SEE BILL OF MATERIAL ON LAST PAGE

**1412CH060536**

This drawing is confidential and must not be reproduced or used without the consent of EXM

Ce dessin est confidentiel et ne doit pas être reproduit ou utilisé sans le consentement de EXM

| NOTE |  |
|------|--|
| ITEM | DESCRIPTION                                    |
| 1    | NEMA 4, 12 Enclosure (IP66)                    |
| 2    | C/W Standard ground standoffs on box and cover |
| 3    | W/O Standard door stiffener                    |
| 4    | W/O Inner panel                                |
| 5    | W/O Inner panel mounting standoffs             |

| No. | Revisions | Date | By/Par |
|-----|-----------|------|--------|
|     |           |      |        |
|     |           |      |        |
|     |           |      |        |
|     |           |      |        |
|     |           |      |        |
|     |           |      |        |

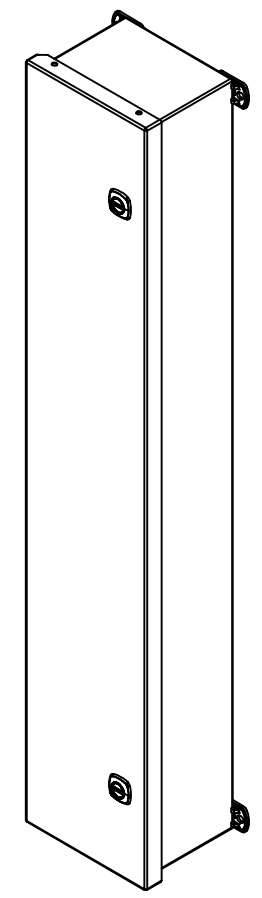

Isometric View



 Tél: (450) 979-4373  
 Fax: (450) 979-4626  
[www.exmweb.com](http://www.exmweb.com)

Flatness  
 Aplatissement  
 Max 3.0mm  
 Projection  

|   |                       |
|---|-----------------------|
| Customer Client   | Date                  |
| Drawn By / Dessiné Par: BoxCad: BoxCad                        | Date: 16-Jan-14       |
| Material / Matière: 16 Ga Cold Rolled A1008 CS Type B (1.4mm) |                       |
| Color / Couleur: Asa-61 Grey                                  | Finish / Fini: Smooth |

|   |             |
|---|-------------|
| Description: 1412CH 36" x 6" x 5" Assembly      | Detail Rev. |
| Part Number / Numéro Pièce: <b>1412CH060536</b> | Rev. 0      |
|   | 2 / 8       |

| Qty        | Part Number   | Rev | Description   |
|------------|---------------|-----|---|
| 3          | STK-A-08126   | 0   | M5 Stainless Steel 316 Nylon Insert Lock Nut with Incorporated Sealing Washer |
| 1          | 1412CH060536C | 0   | 1412CH 36" x 6" Cover   |
| 1          | 1412CH060536B | 0   | 1412CH 36" x 6" x 5" Body   |
| 2          | STK-K-02570   | 0   | 1412 CH Accessory Kit   |
| Parts List |               |     |   |

| PACKING              |     |   |
|----------------------|-----|---|
| ITEM                 | QTY | DESCRIPTION                             |
| Cardboard sleeve     | 1   | Top                                     |
| Thermal plastic film | 1   | Use with Packing Tunnel Wrapper Machine |
| Packaging label      | 1   | White label with product number         |

This drawing is confidential and must not be reproduced or used without the consent of EXM

Ce dessin est confidentiel et ne doit pas être reproduit ou utilisé sans le consentement de EXM



TOP

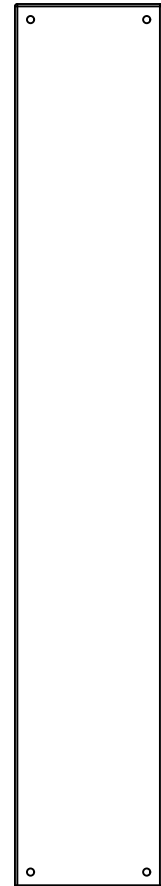

BACK

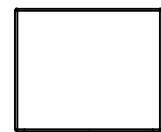

BOTTOM

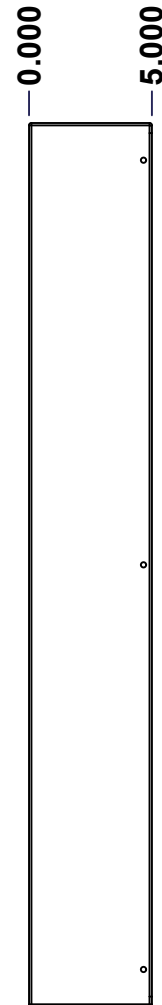

LEFT

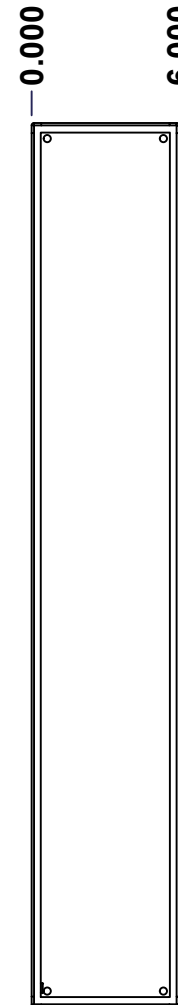

FRONT

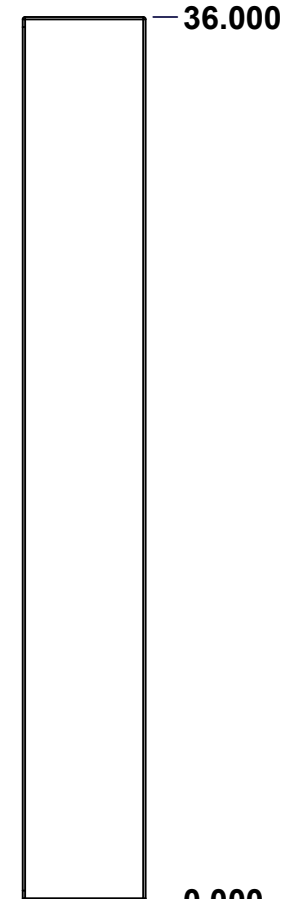

RIGHT

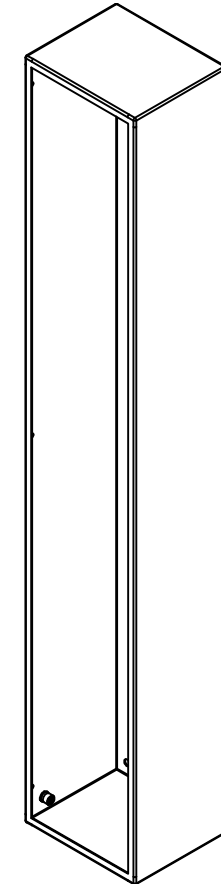

Isometric View

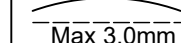
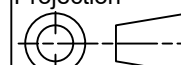

| No. | Revisions | Date | By/Par |
|-----|-----------|------|--------|
|     |           |      |        |
|     |           |      |        |
|     |           |      |        |
|     |           |      |        |

|  |   |  |
|--|---|--|
|  Tél: (450) 979-4373<br>Fax: (450) 979-4626<br><a href="http://www.exmweb.com">www.exmweb.com</a> |   | Flatness<br>Aplatissement<br><br>Max 3.0mm<br>Projection<br> |
| Customer Client  | Date                                      |  |
| Drawn By<br>Dessiné Par  | BoxCad: BoxCad                            | Date 16-Jan-14   |
| Material<br>Matière  | 16 Ga Cold Rolled A1008 CS Type B (1.4mm) |  |
| Color<br>Couleur   | Asa-61 Grey                               | Finish<br>Fini Smooth  |
| Description  | Detail Rev.                               |  |
| 1412CH 36" x 6" x 5" Body  |   |  |
| Part Number<br>Numéro Pièce  | Rev.                                      | 3  |
| <b>1412CH060536B</b>   | <b>0</b>                                  | 8  |

SEE BILL OF MATERIAL ON LAST PAGE

This drawing is confidential and must not be reproduced or used without the consent of EXM

Ce dessin est confidentiel et ne doit pas être reproduit ou utilisé sans le consentement de EXM

| <b>STANDARD FEATURES ARE NOT LISTED IN THIS HOLE TABLE</b> |       |       |                             |
|--|-------|-------|-----------------------------|
| <b>HOLE TABLE - LEFT VIEW (CUSTOM FEATURE ONLY)</b>        |       |       |                             |
| CUT-OUT  | XDIM  | YDIM  | DESCRIPTION                 |
| 1  | 4.000 | 0.750 | STANDOFF M6 x 10mm (Inside) |

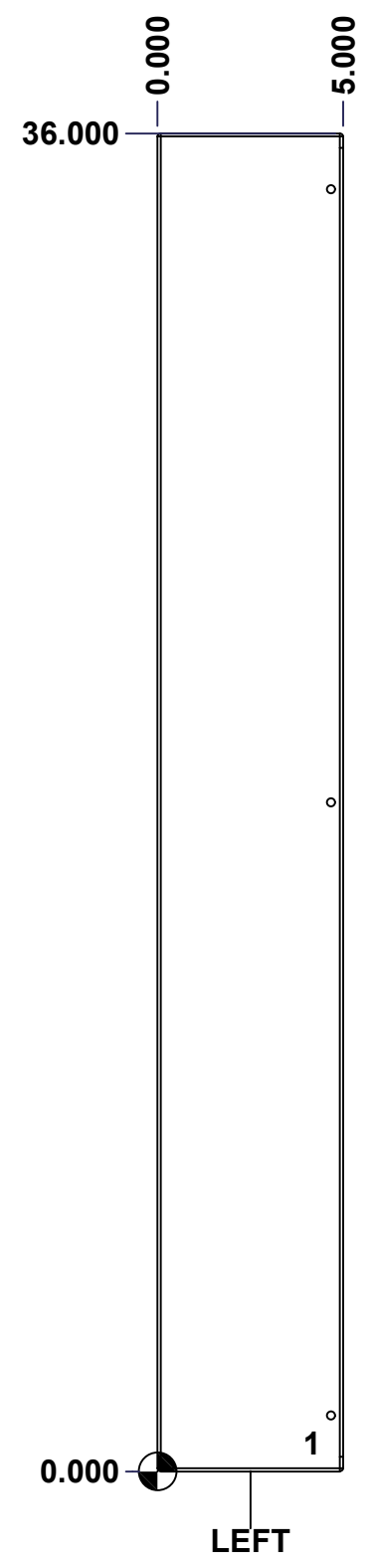

|  |                             |          |        |
|--|-----------------------------|----------|--------|
|  | Description                 | Status   |        |
|  | 1412CH 36" x 6" x 5" Body   | (NULL)   |        |
|  | Part Number<br>Numéro Pièce | Rev.     |        |
|  | <b>1412CH060536B</b>        | <b>0</b> | 4<br>8 |

This drawing is confidential and must not be reproduced or used without the consent of EXM

Ce dessin est confidentiel et ne doit pas être reproduit ou utilisé sans le consentement de EXM

| No. | Revisions | Date | By/Par |
|-----|-----------|------|--------|
|     |           |      |        |
|     |           |      |        |
|     |           |      |        |
|     |           |      |        |
|     |           |      |        |



Isometric View

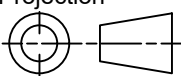

|  |   |   |
|--|---|---|
|  Tél: (450) 979-4373<br>Fax: (450) 979-4626<br><a href="http://www.exmweb.com">www.exmweb.com</a> | Flatness<br>Aplatissement                 | Max 3.0mm   |
|  | Projection                                |  |
| Customer<br>Client   | Date                                      |   |
| Drawn By<br>Dessiné Par  | BoxCad: BoxCad                            | Date 16-Jan-14  |
| Material<br>Matière  | 16 Ga Cold Rolled A1008 CS Type B (1.4mm) |   |
| Color<br>Couleur   | Asa-61 Grey                               | Finish<br>Fini Smooth   |
| Description  | Detail Rev.                               |   |
| 1412CH 36" x 6" x 5" Body  |   |   |
| Part Number<br>Numéro Pièce  | Rev.                                      | 5   |
| <b>1412CH060536B</b>   | <b>0</b>                                  | 8   |

| Qty        | Part Number     | Rev | Description                         |
|------------|-----------------|-----|-------------------------------------|
| 1          | STK-Q-08350     | 5   | Standoff M6 x 10mm                  |
| 1          | STK-P-02400S    | 0   | Powder Paint (Asa-61 Grey / Smooth) |
| 1          | 1412CH060536B-P | 0   | 1412CH 36" x 6" x 5" Body Part      |
| Parts List |                 |     |                                     |

This drawing is confidential and must not be reproduced or used without the consent of EXM

Ce dessin est confidentiel et ne doit pas être reproduit ou utilisé sans le consentement de EXM

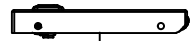

TOP

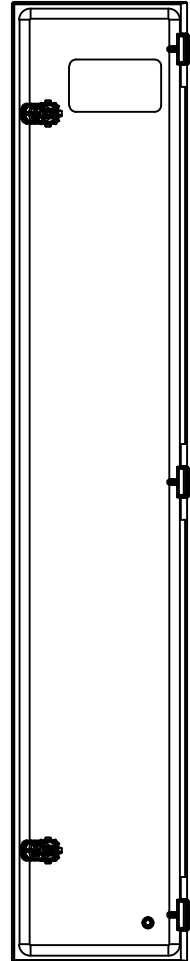

BACK

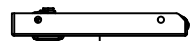

BOTTOM

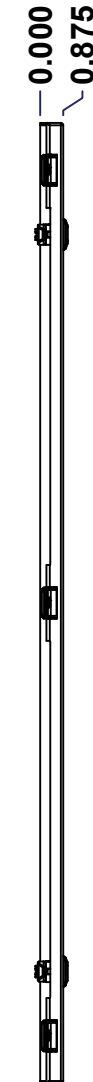

LEFT

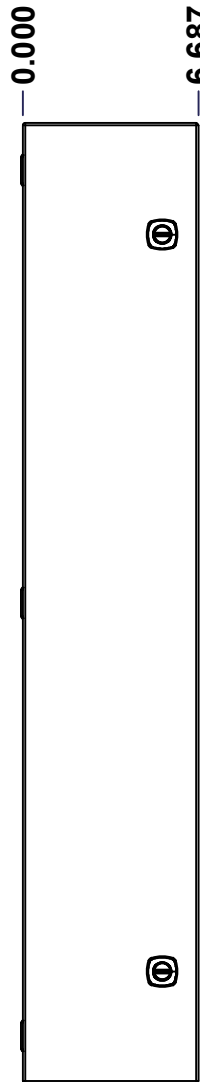

FRONT

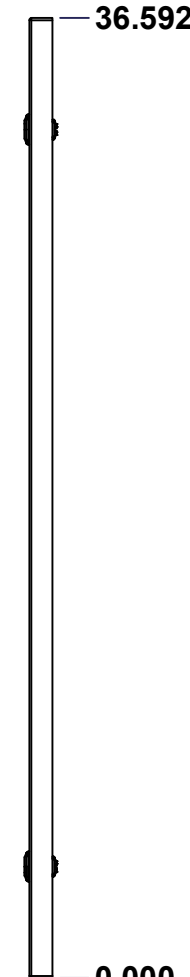

RIGHT

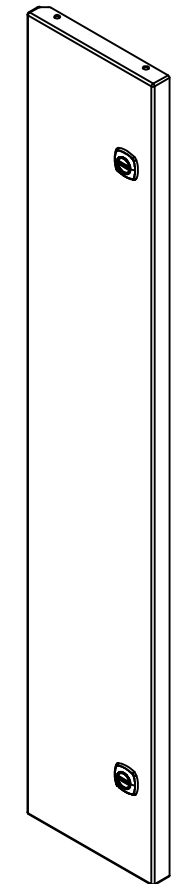

Isometric View

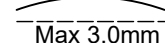
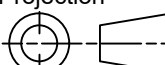

| No. | Revisions | Date | By/Par |
|-----|-----------|------|--------|
|     |           |      |        |
|     |           |      |        |
|     |           |      |        |
|     |           |      |        |

|  |   |  |
|--|---|--|
|  Tél: (450) 979-4373<br>Fax: (450) 979-4626<br><a href="http://www.exmweb.com">www.exmweb.com</a> |   | Flatness<br>Aplatissement<br><br>Max 3.0mm<br>Projection<br> |
| Customer Client  | Date                                      |  |
| Drawn By<br>Dessiné Par  | BoxCad: BoxCad                            | Date 16-Jan-14   |
| Material<br>Matière  | 16 Ga Cold Rolled A1008 CS Type B (1.4mm) |  |
| Color<br>Couleur   | Asa-61 Grey                               | Finish<br>Fini Smooth  |
| Description  | Detail Rev.                               |  |
| 1412CH 36" x 6" Cover  |   |  |
| Part Number<br>Numéro Pièce  | Rev.                                      | 6  |
| <b>1412CH060536C</b>   | <b>0</b>                                  | 8  |

SEE BILL OF MATERIAL ON LAST PAGE

This drawing is confidential and must not be reproduced or used without the consent of EXM

Ce dessin est confidentiel et ne doit pas être reproduit ou utilisé sans le consentement de EXM

| STANDARD FEATURES ARE NOT LISTED IN THIS HOLE TABLE |       |        |                             |
|---|-------|--------|-----------------------------|
| HOLE TABLE - FRONT VIEW (CUSTOM FEATURE ONLY)       |       |        |                             |
| CUT-OUT   | XDIM  | YDIM   | DESCRIPTION                 |
| 1   | 1.500 | 1.500  | STANDOFF M6 x 10mm (Inside) |
| 2   | 5.307 | 4.250  | LOCK 880 SCQ4CH-SL @ 0.0°   |
| 3   | 5.307 | 32.342 | LOCK 880 SCQ4CH-SL @ 0.0°   |

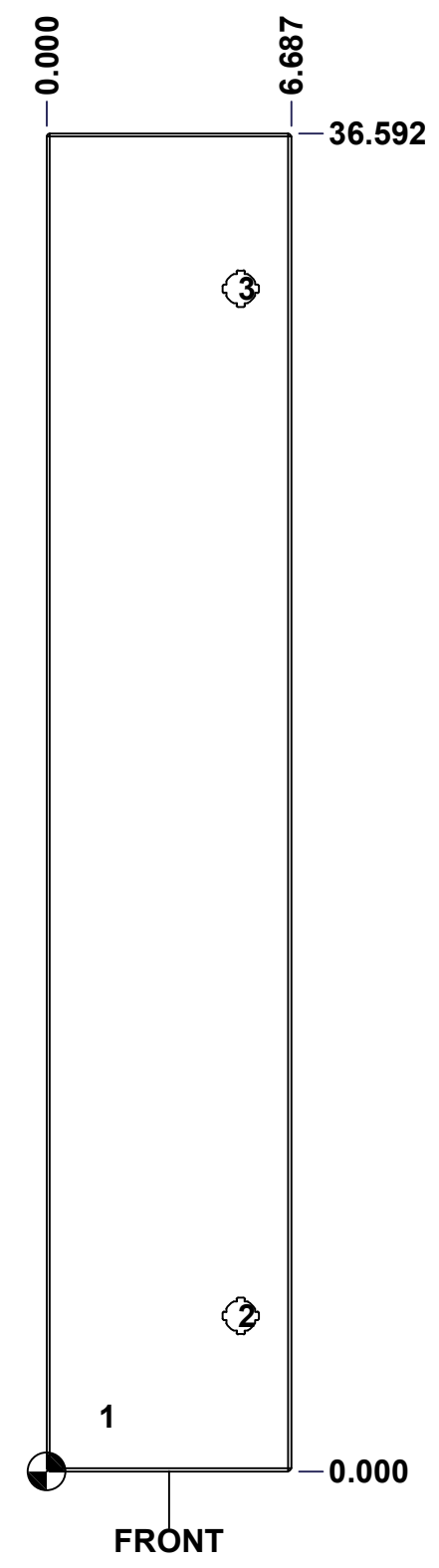

|  |                             |          |     |
|--|-----------------------------|----------|-----|
|  | Description                 | Status   |     |
|  | 1412CH 36" x 6" Cover       | (NULL)   |     |
|  | Part Number<br>Numéro Pièce | Rev.     |     |
|  | <b>1412CH060536C</b>        | <b>0</b> | 7/8 |

This drawing is confidential and must not be reproduced or used without the consent of EXM

Ce dessin est confidentiel et ne doit pas être reproduit ou utilisé sans le consentement de EXM

| No. | Revisions | Date | By/Par |
|-----|-----------|------|--------|
|     |           |      |        |
|     |           |      |        |
|     |           |      |        |
|     |           |      |        |
|     |           |      |        |

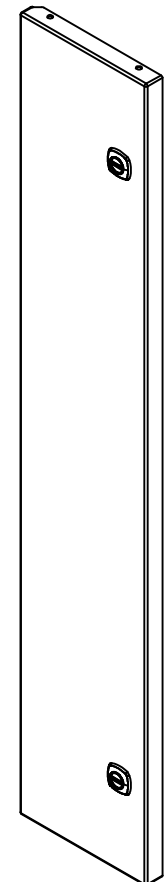

Isometric View

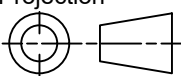

|  |   |   |
|--|---|---|
|  Tél: (450) 979-4373<br>Fax: (450) 979-4626<br><a href="http://www.exmweb.com">www.exmweb.com</a> | Flatness<br>Aplatissement                 | Max 3.0mm   |
|  | Projection                                |  |
| Customer<br>Client   | Date                                      |   |
| Drawn By<br>Dessiné Par  | BoxCad: BoxCad                            | Date 16-Jan-14  |
| Material<br>Matière  | 16 Ga Cold Rolled A1008 CS Type B (1.4mm) |   |
| Color<br>Couleur   | Asa-61 Grey                               | Finish<br>Fini Smooth   |
| Description  | Detail Rev.                               |   |
| 1412CH 36" x 6" Cover  |   |   |
| Part Number<br>Numéro Pièce  | Rev.                                      | 8   |
| <b>1412CH060536C</b>   | <b>0</b>                                  | <b>8</b>  |

| QTY        | Part Number     | Rev | Description                            |
|------------|-----------------|-----|--|
| 2          | 880 SCQ4CH-SL   | 0   | 5412 CH 1/4 Turn Lock                  |
| 1          | STK-Q-08350     | 5   | Standoff M6 x 10mm                     |
| 1          | STK-P-02400S    | 0   | Powder Paint (Asa-61 Grey / Smooth)    |
| 1          | STK-S-00100     | 0   | 3.5" x 2" Silver Milar Flexcon Sticker |
| 3          | STK-A-33033     | 6   | 5412 ESCH Hinge Assembly               |
| 1          | 1412CH060536G   | 0   | 1412CH 36" x 6" Gasket                 |
| 1          | 1412CH060536C-P | 0   | 1412CH 36" x 6" Cover Part             |
| Parts List |                 |     |  |