

This drawing is confidential and must not be reproduced or used without the consent of EXM

Ce dessin est confidentiel et ne doit pas être reproduit ou utilisé sans le consentement de EXM

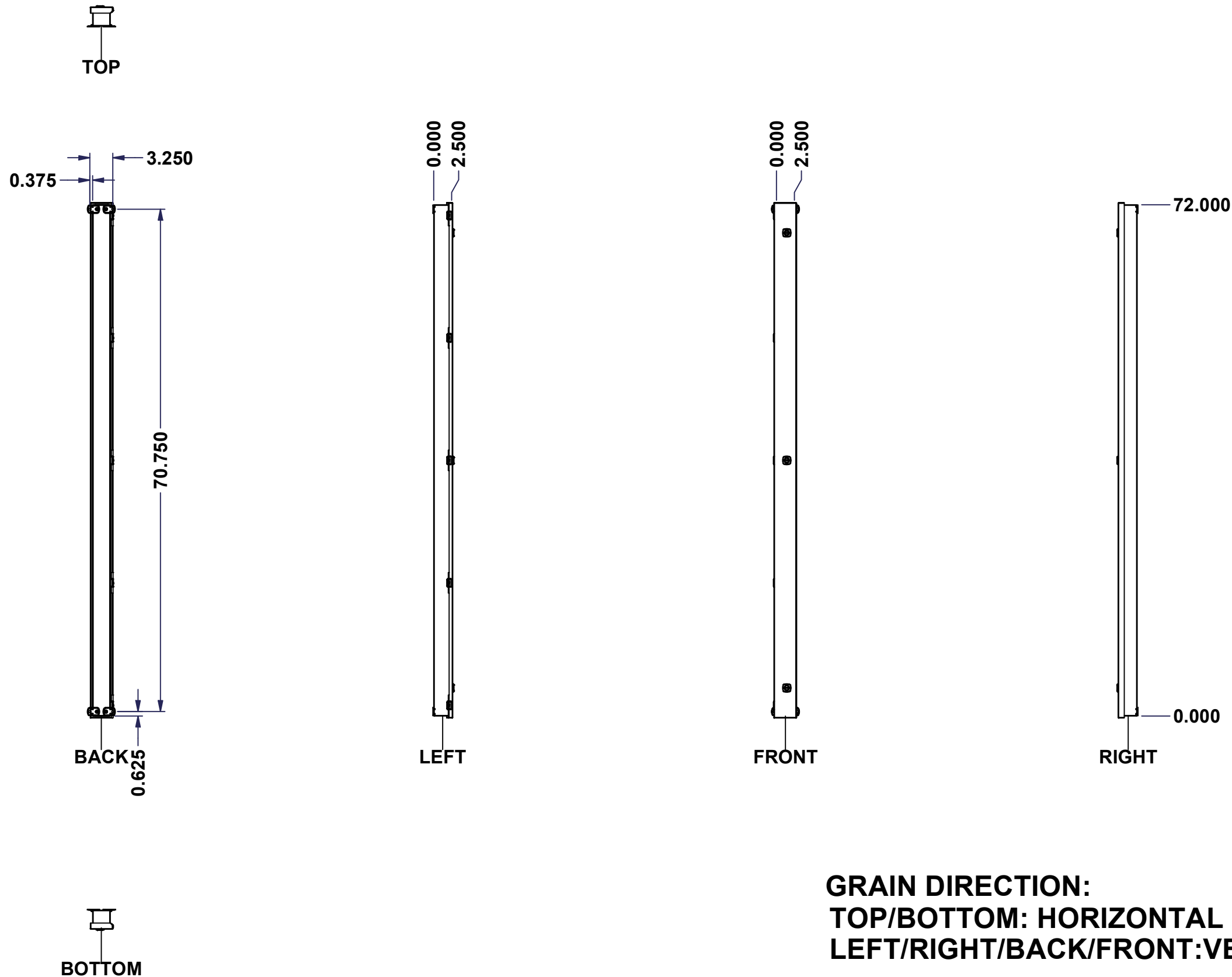

**GRAIN DIRECTION:
TOP/BOTTOM: HORIZONTAL
LEFT/RIGHT/BACK/FRONT: VERTICAL**

No.	Revisions	Date	By/Par

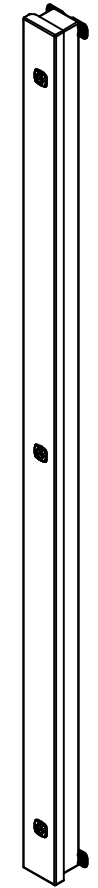

Isometric View



Tél: (450) 979-4373 Fax: (450) 979-4626 www.exmweb.com		Flatness Aplatissement Max 3.0mm Projection
Customer Client	Date	
Drawn By Dessiné Par	BoxCad: BoxCad	Date 16-Mar-16
Material Matière	16 Ga Stainless Steel 304 (1.4mm)	
Color Couleur	Unpainted	Finish Fini Brushed
Description	Detail Rev.	
1412CH 72" x 2.5" x 2.5" Assembly		
Part Number Numéro Pièce	Rev.	1
1412CHSS020272	0	8

SEE BILL OF MATERIAL ON LAST PAGE

This drawing is confidential and must not be reproduced or used without the consent of EXM

Ce dessin est confidentiel et ne doit pas être reproduit ou utilisé sans le consentement de EXM

NOTE	
ITEM	DESCRIPTION
1	4X Enclosure (IP66)
2	W/O Standard ground standoffs on box and cover
3	W/O Standard door stiffener
4	W/O Inner panel
5	W/O Inner panel mounting standoffs

No.	Revisions	Date	By/Par

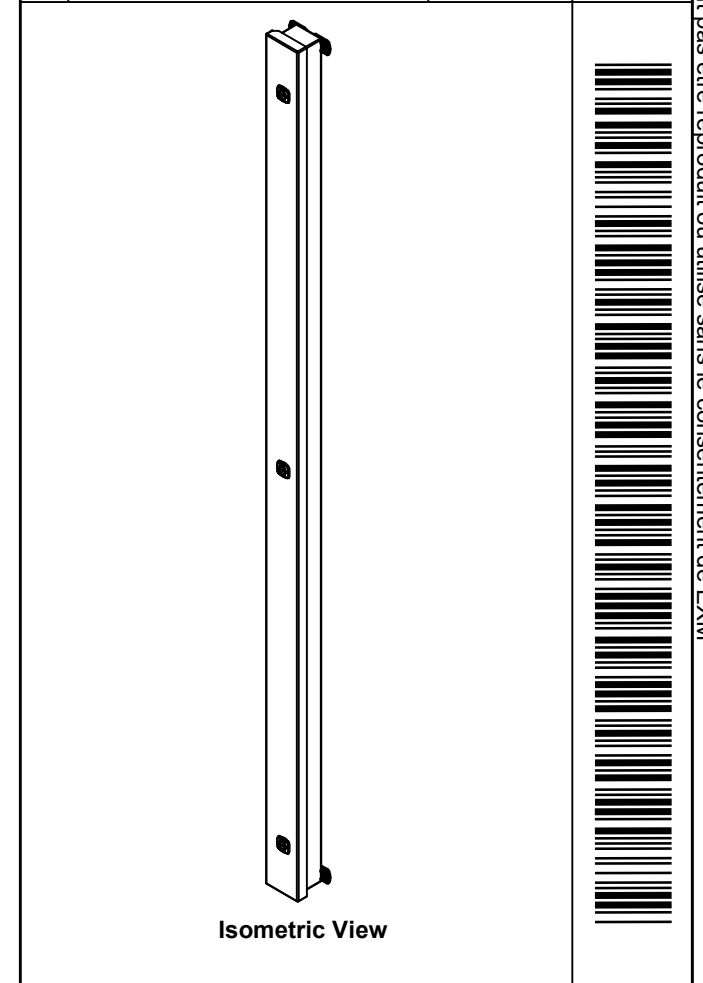

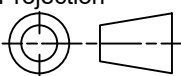
 Tél: (450) 979-4373 Fax: (450) 979-4626 www.exmweb.com		Flatness Aplatissement Max 3.0mm Projection 
Customer Client	Date	
Drawn By Dessiné Par	BoxCad: BoxCad	Date 16-Mar-16
Material Matière	16 Ga Stainless Steel 304 (1.4mm)	
Color Couleur	Unpainted	Finish Fini Brushed
Description	Detail Rev.	
1412CH 72" x 2.5" x 2.5" Assembly		
Part Number Numéro Pièce	1412CHSS020272	Rev. 2
		0
		8

PACKING		
ITEM	QTY	DESCRIPTION
Cardboard sleeve	1	Top
Thermal plastic film	1	Use with Packing Tunnel Wrapper Machine
Packaging label	1	White label with product number

Qty	Part Number	Rev	Description
5	STK-A-08126	0	M5 Stainless Steel 316 Nylon Insert Lock Nut with Incorporated Sealing Washer
1	1412CHSS020272C	0	1412CH 72" x 2.5" Cover
1	1412CHSS020272B	0	1412CH 72" x 2.5" x 2.5" Body
2	STK-K-02575	0	1412 CHSS Accessory Kit
Parts List			

This drawing is confidential and must not be reproduced or used without the consent of EXM

Ce dessin est confidentiel et ne doit pas être reproduit ou utilisé sans le consentement de EXM

No.	Revisions	Date	By/Par

TOP

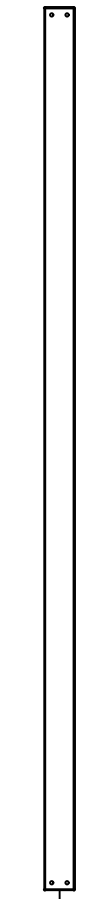

BACK

0.000
2.500

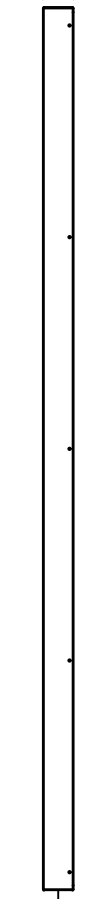

LEFT

0.000
2.500

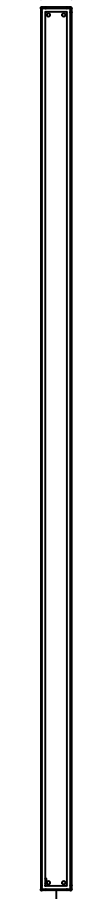

FRONT

72.000

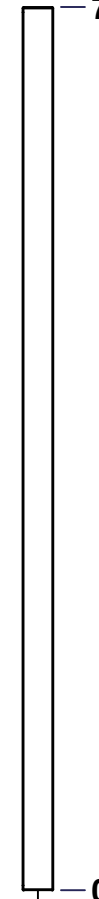

RIGHT

0.000

BOTTOM

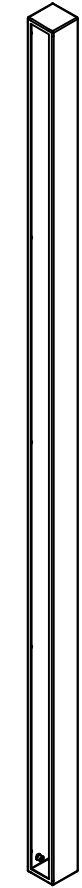

Isometric View



Tél: (450) 979-4373
Fax: (450) 979-4626
www.exmweb.com

Flatness
Aplatissement
Max 3.0mm
Projection

Customer Client	Date
Drawn By Dessiné Par BoxCad: BoxCad	Date 16-Mar-16
Material Matière 16 Ga Stainless Steel 304 (1.4mm)	
Color Couleur Unpainted	Finish Fini Brushed
Description 1412CH 72" x 2.5" x 2.5" Body	Detail Rev.
Part Number Numéro Pièce 1412CHSS020272B	Rev. 3 0

SEE BILL OF MATERIAL ON LAST PAGE

This drawing is confidential and must not be reproduced or used without the consent of EXM

Ce dessin est confidentiel et ne doit pas être reproduit ou utilisé sans le consentement de EXM

STANDARD FEATURES ARE NOT LISTED IN THIS HOLE TABLE			
HOLE TABLE - LEFT VIEW (CUSTOM FEATURE ONLY)			
CUT-OUT	XDIM	YDIM	DESCRIPTION
1	1.500	0.750	STANDOFF M6 x 10mm (Inside)

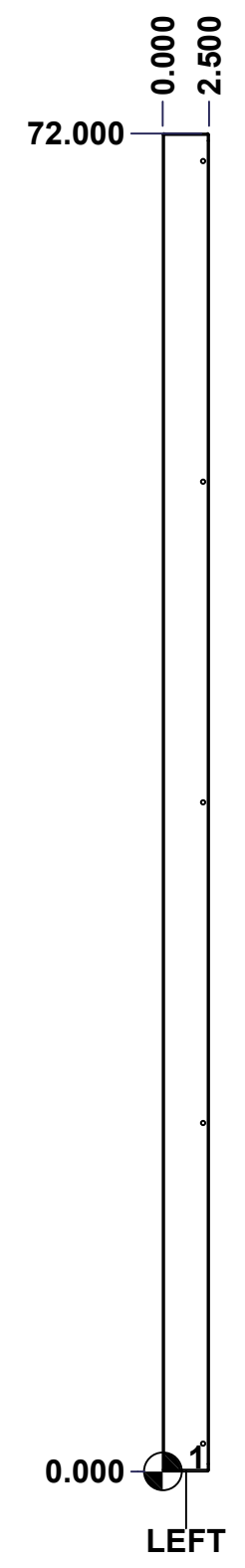

	Description	Status	
	1412CH 72" x 2.5" x 2.5" Body	(NULL)	
	Part Number Numéro Pièce	Rev.	
	1412CHSS020272B	0	4 / 8

This drawing is confidential and must not be reproduced or used without the consent of EXM

Ce dessin est confidentiel et ne doit pas être reproduit ou utilisé sans le consentement de EXM

No.	Revisions	Date	By/Par

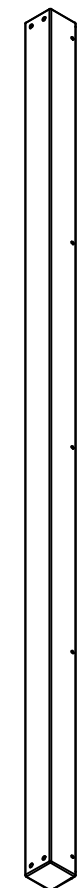

Isometric View

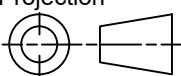

 Tél: (450) 979-4373 Fax: (450) 979-4626 www.exmweb.com		Flatness Aplatissement Max 3.0mm
Customer Client		Projection 
Drawn By / Dessiné Par: BoxCad: BoxCad		Date: 16-Mar-16
Material / Matière: 16 Ga Stainless Steel 304 (1.4mm)		
Color / Couleur: Unpainted	Finish / Fini: Brushed	
Description: 1412CH 72" x 2.5" x 2.5" Body		Detail Rev.
Part Number / Numéro Pièce: 1412CHSS020272B		Rev. 5 0

Qty	Part Number	Rev	Description
1	STK-Q-08500	4	Stainless Steel Standoff M6 x 10mm
1	1412CHSS020272B-P	0	1412CH 72" x 2.5" x 2.5" Body Part
Parts List			

This drawing is confidential and must not be reproduced or used without the consent of EXM

Ce dessin est confidentiel et ne doit pas être reproduit ou utilisé sans le consentement de EXM

No.	Revisions	Date	By/Par

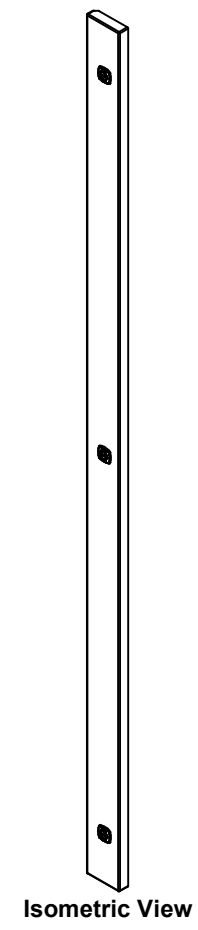
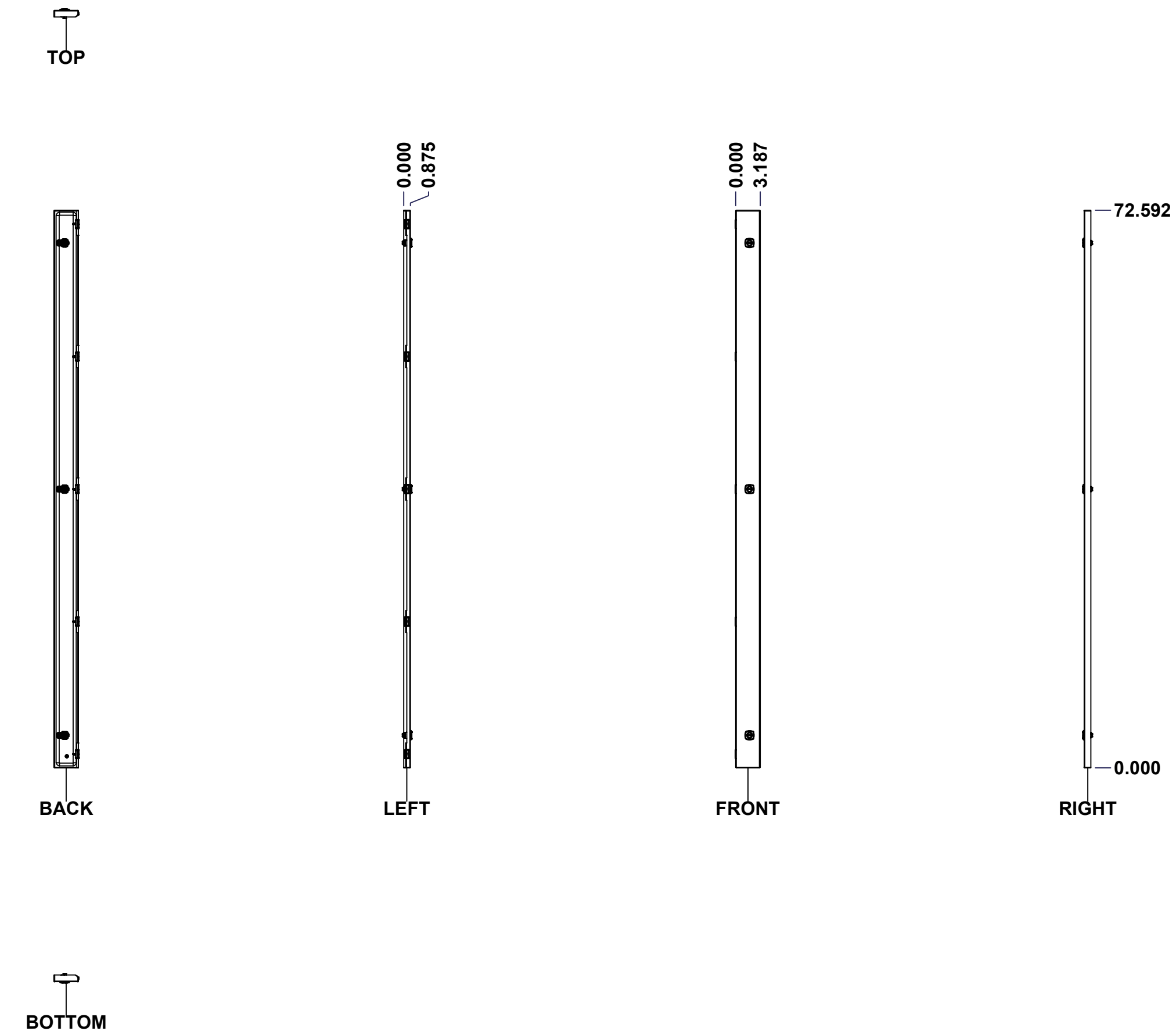

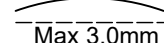
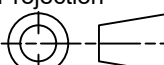
 Tél: (450) 979-4373 Fax: (450) 979-4626 www.exmweb.com		Flatness Aplatissement  Max 3.0mm
Customer Client Drawn By / Dessiné Par: BoxCad: BoxCad		Projection 
Date Date: 16-Mar-16		Material / Matière: 16 Ga Stainless Steel 304 (1.4mm)
Color / Couleur: Unpainted	Finish / Fini: Brushed	
Description: 1412CH 72" x 2.5" Cover		Detail Rev.
Part Number / Numéro Pièce: 1412CHSS020272C		Rev. 6 0

SEE BILL OF MATERIAL ON LAST PAGE

This drawing is confidential and must not be reproduced or used without the consent of EXM

Ce dessin est confidentiel et ne doit pas être reproduit ou utilisé sans le consentement de EXM

STANDARD FEATURES ARE NOT LISTED IN THIS HOLE TABLE

HOLE TABLE - FRONT VIEW (CUSTOM FEATURE ONLY)

CUT-OUT	XDIM	YDIM	DESCRIPTION
1	1.500	1.500	STANDOFF M6 x 10mm (Inside)
2	1.807	4.250	LOCK 880 SCQ4CH-SLSS @ 0.0°
3	1.807	36.296	LOCK 880 SCQ4CH-SLSS @ 0.0°
4	1.807	68.342	LOCK 880 SCQ4CH-SLSS @ 0.0°

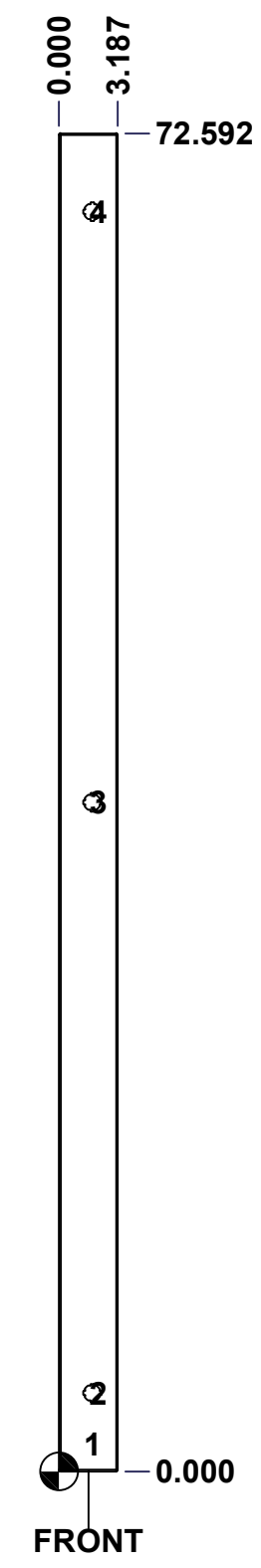

	Description	Status	
	1412CH 72" x 2.5" Cover	(NULL)	
	Part Number Numéro Pièce	Rev.	
	1412CHSS020272C	0	7/8

This drawing is confidential and must not be reproduced or used without the consent of EXM

Ce dessin est confidentiel et ne doit pas être reproduit ou utilisé sans le consentement de EXM

No.	Revisions	Date	By/Par

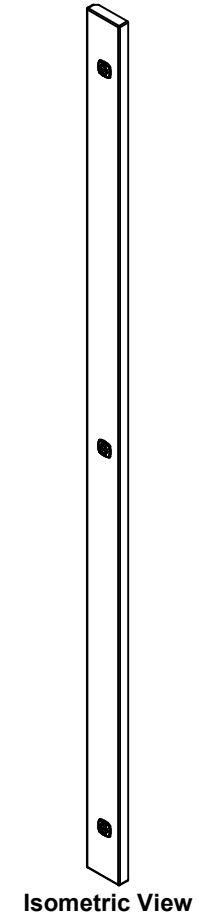

Tél: (450) 979-4373 Fax: (450) 979-4626 www.exmweb.com		Flatness Aplatissement
		Max 3.0mm
Projection		
Customer Client		Date
Drawn By Dessiné Par	BoxCad: BoxCad	Date 16-Mar-16
Material Matière	16 Ga Stainless Steel 304 (1.4mm)	
Color Couleur	Unpainted	Finish Fini Brushed
Description		Detail Rev.
1412CH 72" x 2.5" Cover		
Part Number Numéro Pièce	Rev.	8
1412CHSS020272C	0	8

3	880 SCQ4CH-SLSS	0	5412 CHSS 1/4 Turn Lock
1	STK-Q-08500	4	Stainless Steel Standoff M6 x 10mm
5	STK-A-33038	5	5412 ESSCH Hinge Assembly
1	1412CHSS020272G	0	1412CH 72" x 2.5" Gasket
1	1412CHSS020272C-P	0	1412CH 72" x 2.5" Cover Part
QTY	Part Number	Rev	Description
Parts List			