

This drawing is confidential and must not be reproduced or used without the consent of EXM

Ce dessin est confidentiel et ne doit pas être reproduit ou utilisé sans le consentement de EXM

NOTE	
ITEM	DESCRIPTION
1	NEMA 4, 12 Enclosure (IP66)

No.	Revisions	Date	By/Par

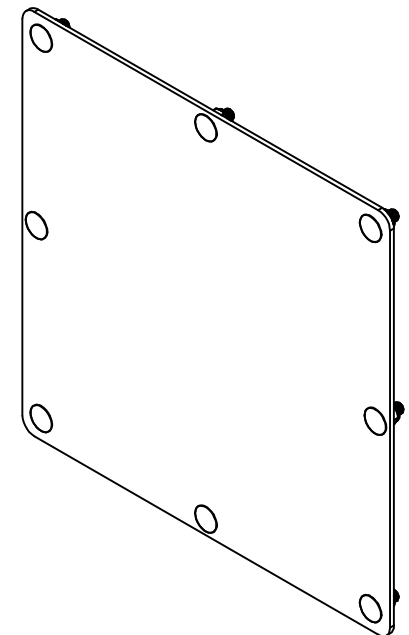
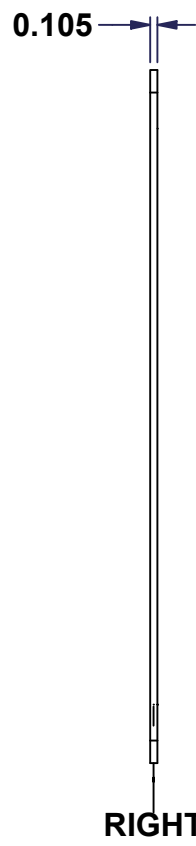
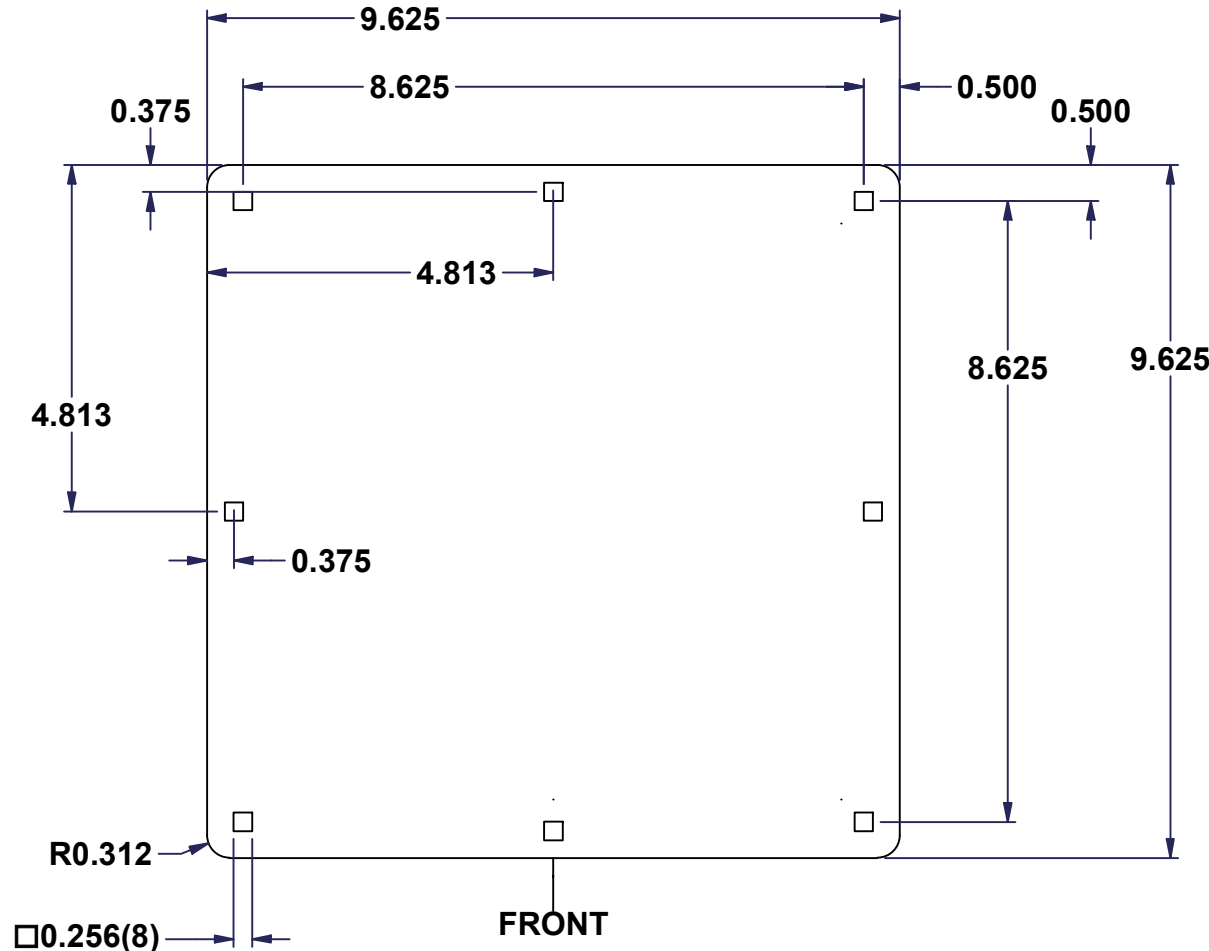

Isometric View

Note:
- Remove all sharp corners and deburr edges

 Tél: (450) 979-4373
 Fax: (450) 979-4626
www.exmweb.com

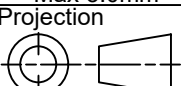
Flatness Aplatissement: Max 3.0mm
 Projection: 

Customer Client	Date
Drawn By Dessiné Par: BoxCad: BoxCad	Date: 29-Mar-23
Material Matière: 12 Ga Cold Rolled A1008 CS Type B (2.5mm)	
Color Couleur: Asa-61 Grey	Finish Fini: Smooth

PACKING		
ITEM	QTY	DESCRIPTION
Cardboard sleeve	2	Top and Bottom
Plastic strap - Black	2	To Squeeze 2 cardboard sleeve together
Packaging label	3	White label with PN

Qty	Part Number	Rev	Description
1	STK-P-02400S	0	Powder Paint (Asa-61 Grey / Smooth)
8	STK-Q-00266	0	M6 x 16mm Stainless Steel 316 Carriage Bolt
1	1412CP8070-P	0	1412CP8" x 8" Closing Plate Part
8	STK-Q-07225	0	M6 Stainless Steel Nylon Insert Lock Nut

Parts List

Description: 1412CP 8" x 8" x 0.105" Assembly	Detail Rev.
Part Number Numéro Pièce: 1412CP8070	Rev. 0