

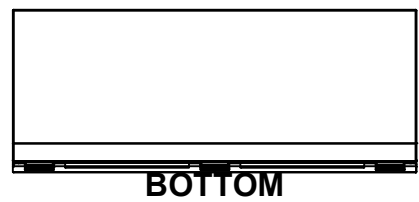

This drawing is confidential and must not be reproduced or used without the consent of EXM

Ce dessin est confidentiel et ne doit pas être reproduit ou utilisé sans le consentement de EXM

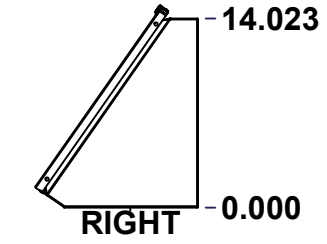
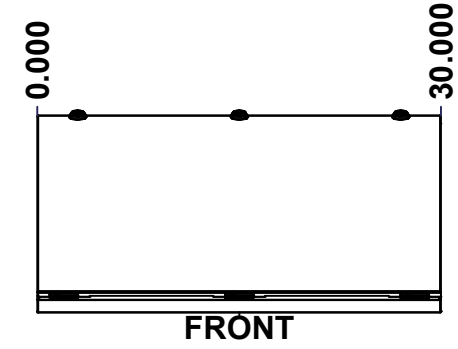
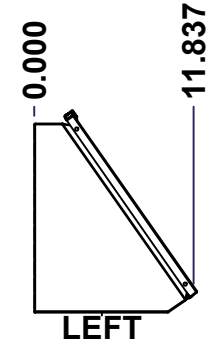
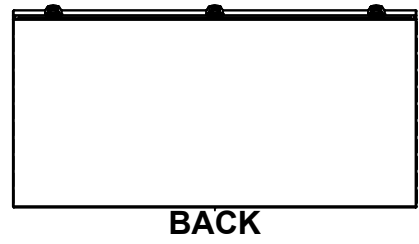
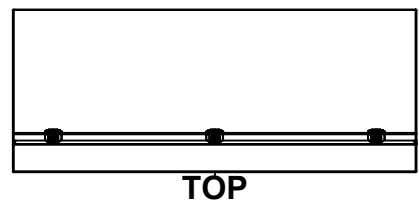
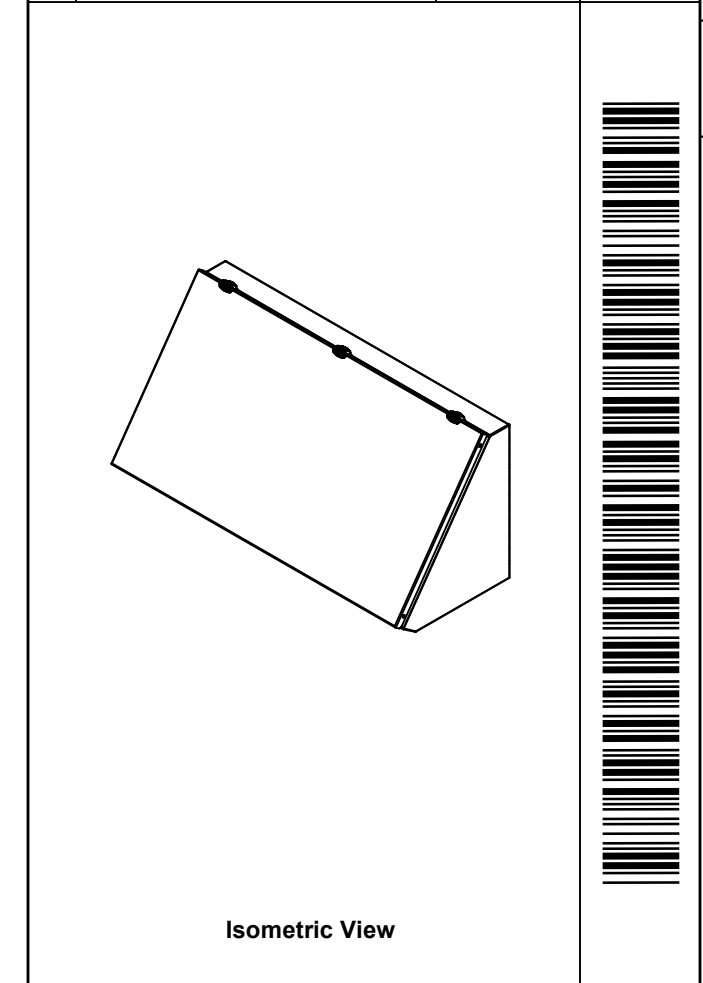

No.	Revisions	Date	By/Par



 Tél: (450) 979-4373 Fax: (450) 979-4626 www.exmweb.com		Flatness Aplatissement
		Max 3.0mm
Customer Client		Date
Drawn By Dessiné Par BoxCad: BoxCad		Date 1/21/2020
Material Matière 16 Ga Cold Rolled A1008 CS Type B (1.4mm)		
Color Couleur Asa-61 Grey	Finish Fini Smooth	
Description 1412CS 16" x 30" x 11.725" Assembly		Detail Rev.
Part Number Numéro Pièce 1412CS163011		Rev. 1
SEE BILL OF MATERIAL ON LAST PAGE		11

This drawing is confidential and must not be reproduced or used without the consent of EXM

Ce dessin est confidentiel et ne doit pas être reproduit ou utilisé sans le consentement de EXM

NOTE	
ITEM	DESCRIPTION
1	NEMA 4/12 Enclosure
2	C/W Standard ground standoffs on box only
3	W/O Inner panel
4	W/O Inner panel mounting standoffs

No.	Revisions	Date	By/Par

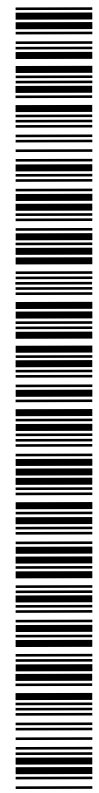
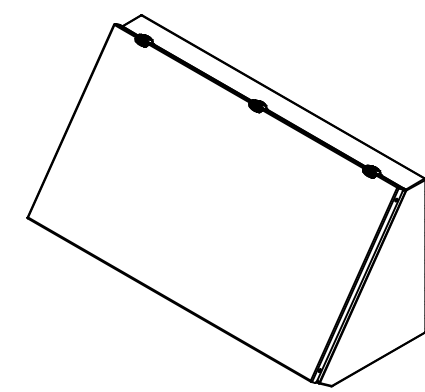

Isometric View



Tél: (450) 979-4373
 Fax: (450) 979-4626
www.exmweb.com

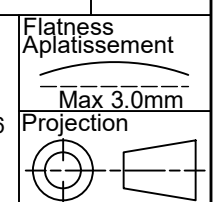

Customer Client	Date
Drawn By / Dessiné Par: BoxCad: BoxCad	Date: 1/21/2020
Material / Matière: 16 Ga Cold Rolled A1008 CS Type B (1.4mm)	

Color / Couleur: Asa-61 Grey	Finish / Fini: Smooth
------------------------------	-----------------------

Description: 1412CS 16" x 30" x 11.725" Assembly	Detail Rev.
--	-------------

Part Number / Numéro Pièce: 1412CS163011	Rev. 0	2 / 11
---	--------	--------

PACKING		
ITEM	QTY	DESCRIPTION
Cardboard sleeve	2	Top and Bottom
Cardboard strip	2	Between back of enclosure and inner panel
Plastic bag	1	To protect cover surface and inside gasket
Plastic strap - Black	2	To Squeeze the 2 cardboard sleeve together
Packaging label	1	White label with product number

Qty	Part Number	Rev	Description
3	STK-Q-08126	0	M5 Stainless Steel 316 Nylon Insert Lock Nut With O-Ring
1	1412CS163011C	0	1412CS 16" x 30" Cover
1	1412CS163011B	0	1412CS 16" x 30" x 11.725" Body
2	886 DS7	1	Gas Spring 115N/12Kg/26Lbs

Parts List

This drawing is confidential and must not be reproduced or used without the consent of EXM

Ce dessin est confidentiel et ne doit pas être reproduit ou utilisé sans le consentement de EXM

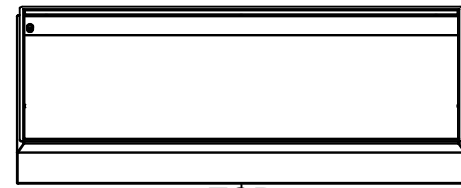

TOP

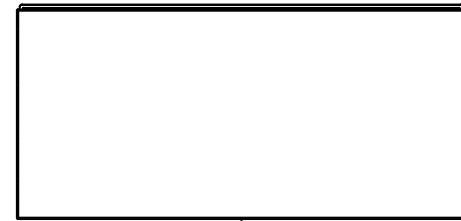

BACK

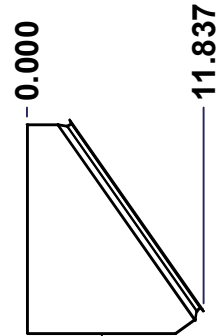

LEFT

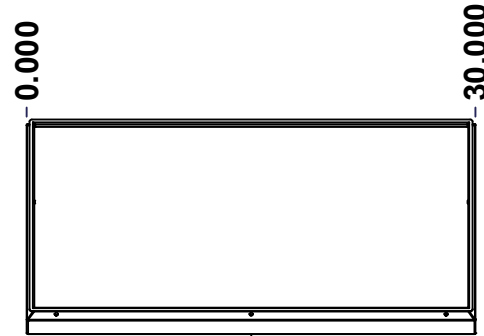

FRONT

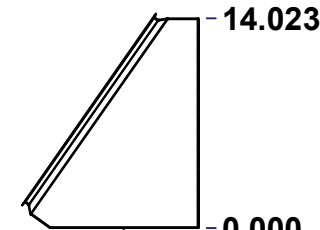

RIGHT



BOTTOM

No.	Revisions	Date	By/Par

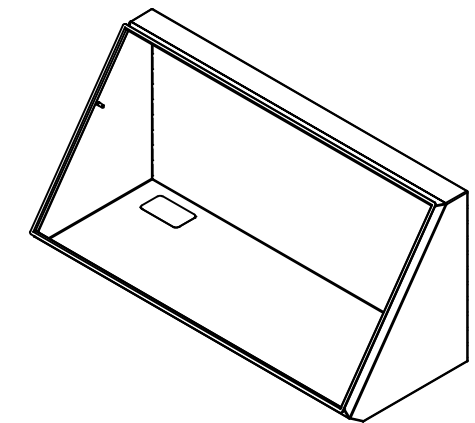

Isometric View



Tél: (450) 979-4373
 Fax: (450) 979-4626
www.exmweb.com

Flatness
Aplatissement

Max 3.0mm

Projection



Customer Client	Date
Drawn By / Dessiné Par: BoxCad: BoxCad	Date: 1/21/2020
Material / Matière: 16 Ga Cold Rolled A1008 CS Type B (1.4mm)	

Color / Couleur: Asa-61 Grey	Finish / Fini: Smooth
------------------------------	-----------------------

Description: 1412CS 16" x 30" x 11.725" Body	Detail Rev.
--	-------------

Part Number / Numéro Pièce: 1412CS163011B	Rev. 0	3	11
---	--------	---	----

SEE BILL OF MATERIAL ON LAST PAGE

This drawing is confidential and must not be reproduced or used without the consent of EXM

Ce dessin est confidentiel et ne doit pas être reproduit ou utilisé sans le consentement de EXM

STANDARD FEATURES ARE NOT LISTED IN THIS HOLE TABLE			
HOLE TABLE - RIGHT VIEW (CUSTOM FEATURE ONLY)			
CUT-OUT	XDIM	YDIM	DESCRIPTION
1	5.205	8.839	STUDSM5 x 12mm (Inside)

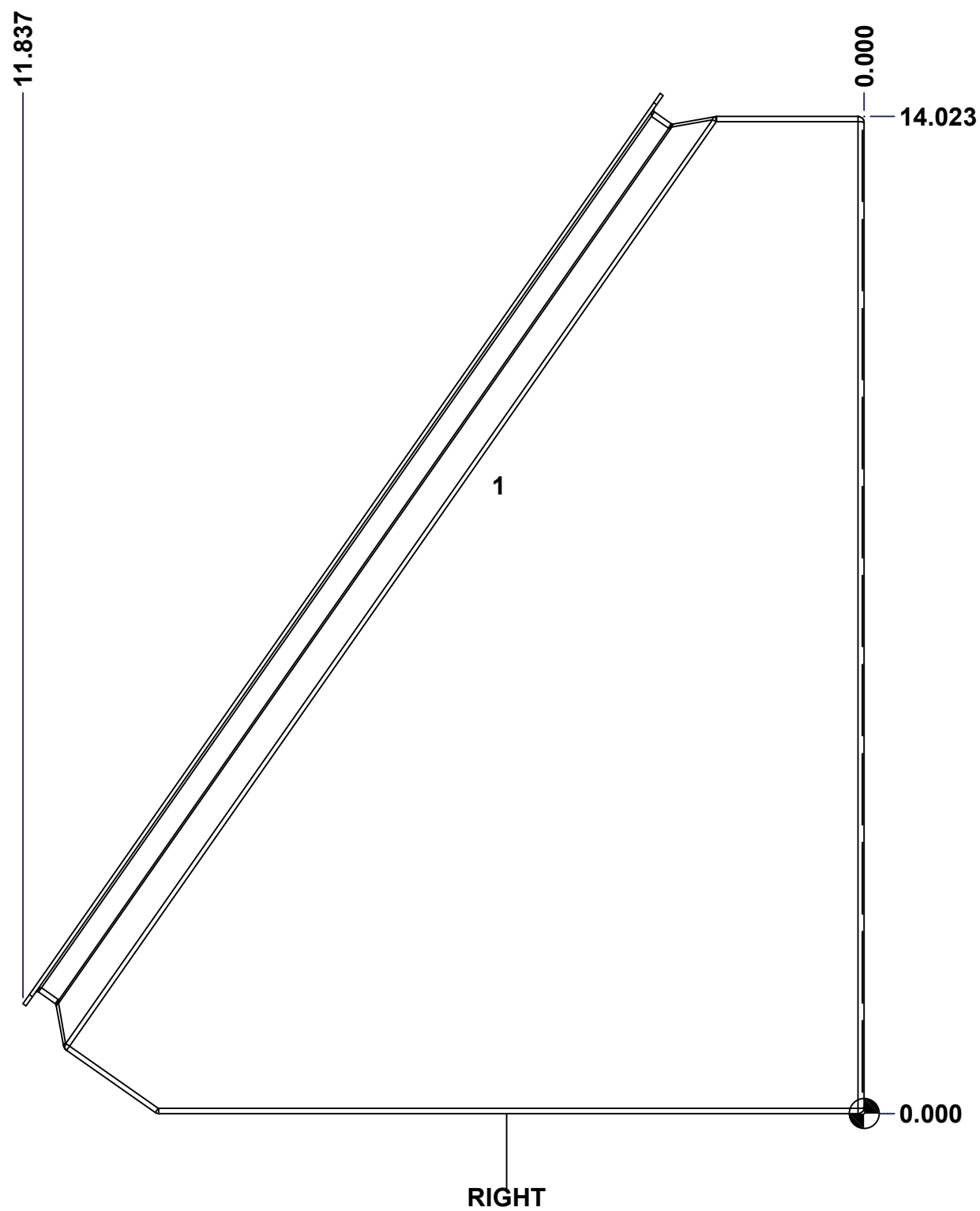

	Description	Status	
	1412CS 16" x 30" x 11.725" Body	(NULL)	
	Part Number Numéro Pièce	Rev.	4
	1412CS163011B	0	11

This drawing is confidential and must not be reproduced or used without the consent of EXM

Ce dessin est confidentiel et ne doit pas être reproduit ou utilisé sans le consentement de EXM

STANDARD FEATURES ARE NOT LISTED IN THIS HOLE TABLE			
HOLE TABLE - BOTTOM VIEW (CUSTOM FEATURE ONLY)			
CUT-OUT	XDIM	YDIM	DESCRIPTION
1	3.500	2.000	LABEL_EXM (Inside)

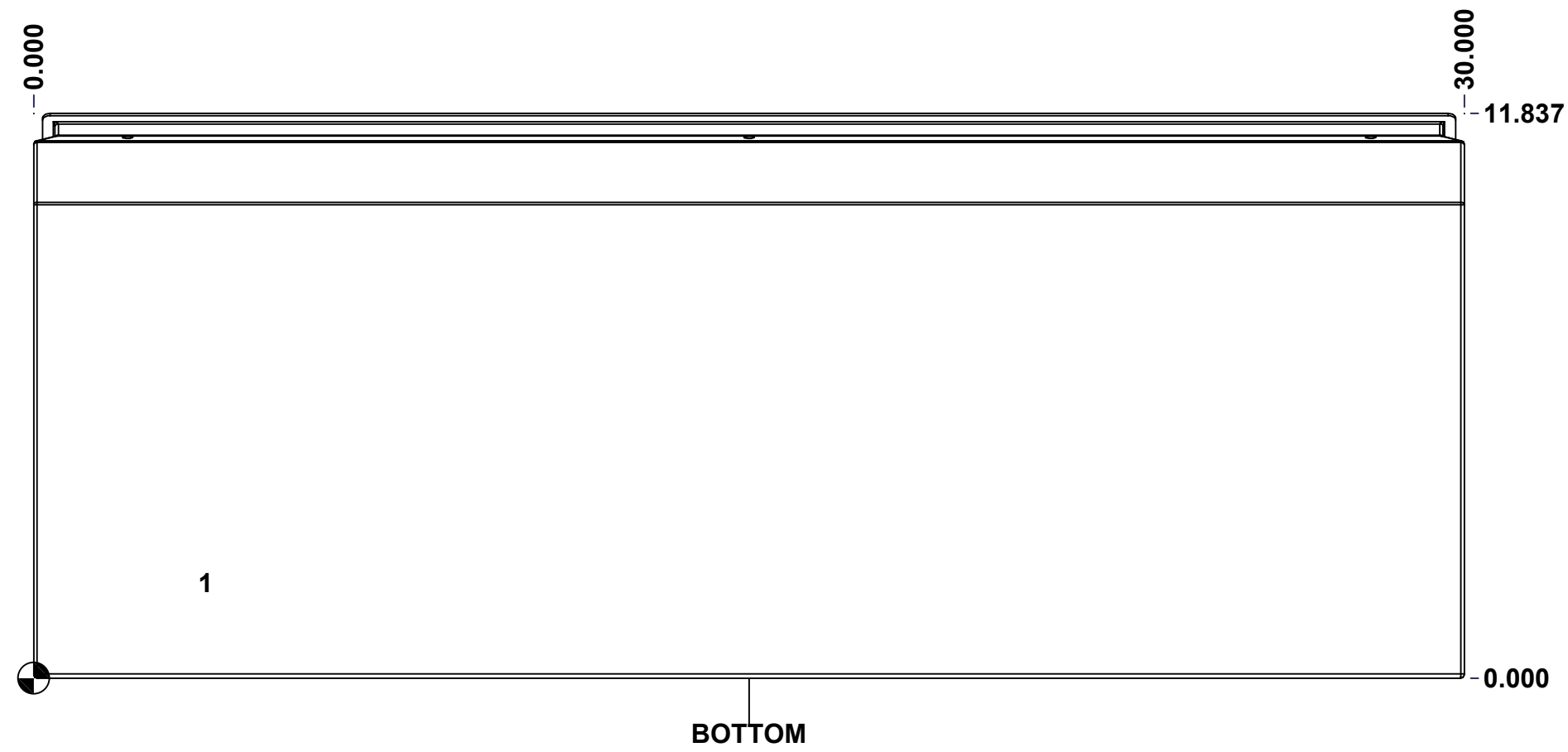

	Description	Status	
	1412CS 16" x 30" x 11.725" Body	(NULL)	
	Part Number Numéro Pièce	Rev.	5
	1412CS163011B	0	11

This drawing is confidential and must not be reproduced or used without the consent of EXM

Ce dessin est confidentiel et ne doit pas être reproduit ou utilisé sans le consentement de EXM

STANDARD FEATURES ARE NOT LISTED IN THIS HOLE TABLE			
HOLE TABLE - LEFT VIEW (CUSTOM FEATURE ONLY)			
CUT-OUT	XDIM	YDIM	DESCRIPTION
1	5.205	8.839	STUDSM5 x 12mm (Inside)

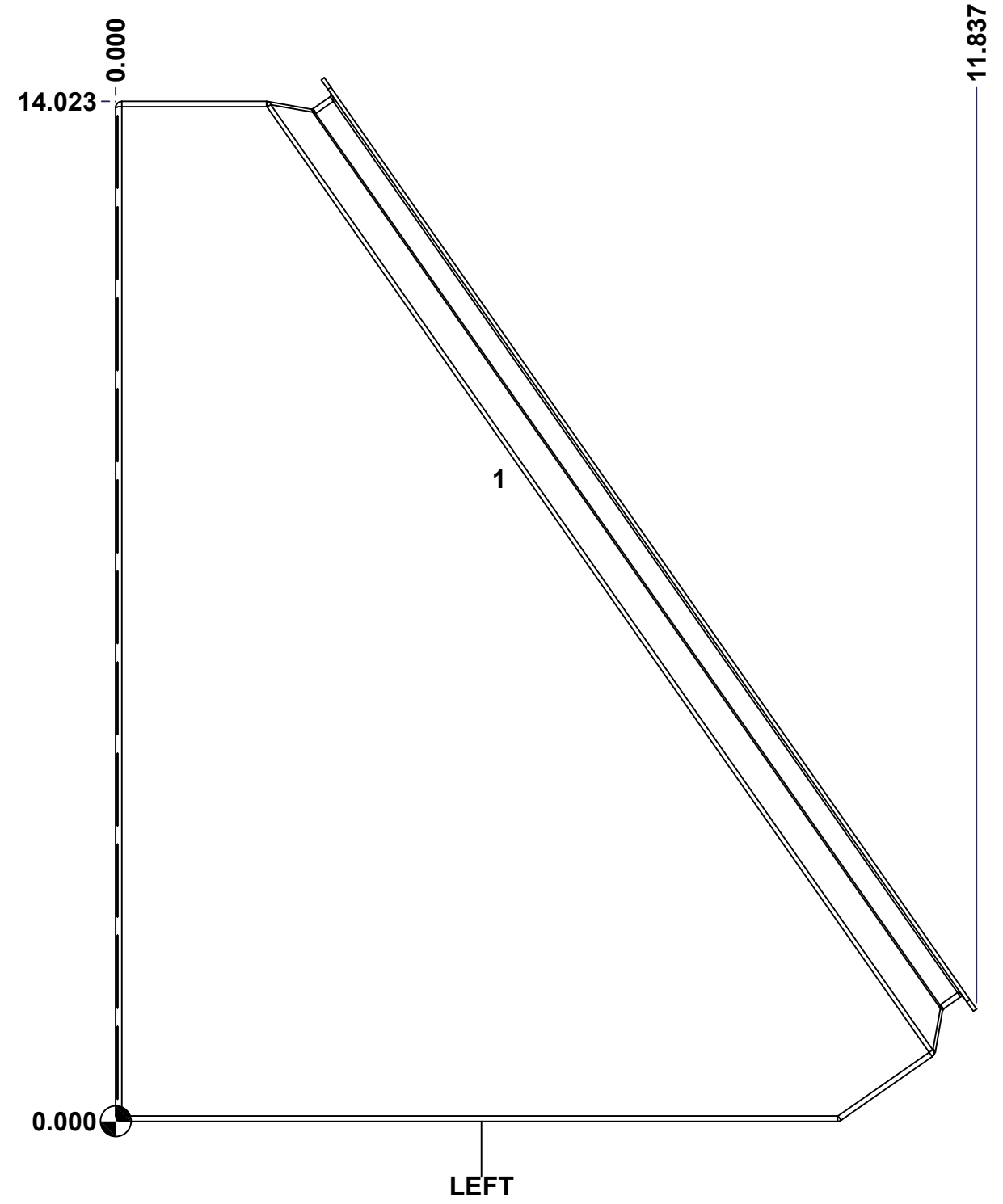

	Description	Status
	1412CS 16" x 30" x 11.725" Body	(NULL)
	Part Number Numéro Pièce	Rev.
	1412CS163011B	0
		6
		11

This drawing is confidential and must not be reproduced or used without the consent of EXM

Ce dessin est confidentiel et ne doit pas être reproduit ou utilisé sans le consentement de EXM

STANDARD FEATURES ARE NOT LISTED IN THIS HOLE TABLE			
HOLE TABLE - ANGLE VIEW (CUSTOM FEATURE ONLY)			
CUT-OUT	XDIM	YDIM	DESCRIPTION
1	29.125	0.742	STANDOFF M6 x 10mm (Inside)

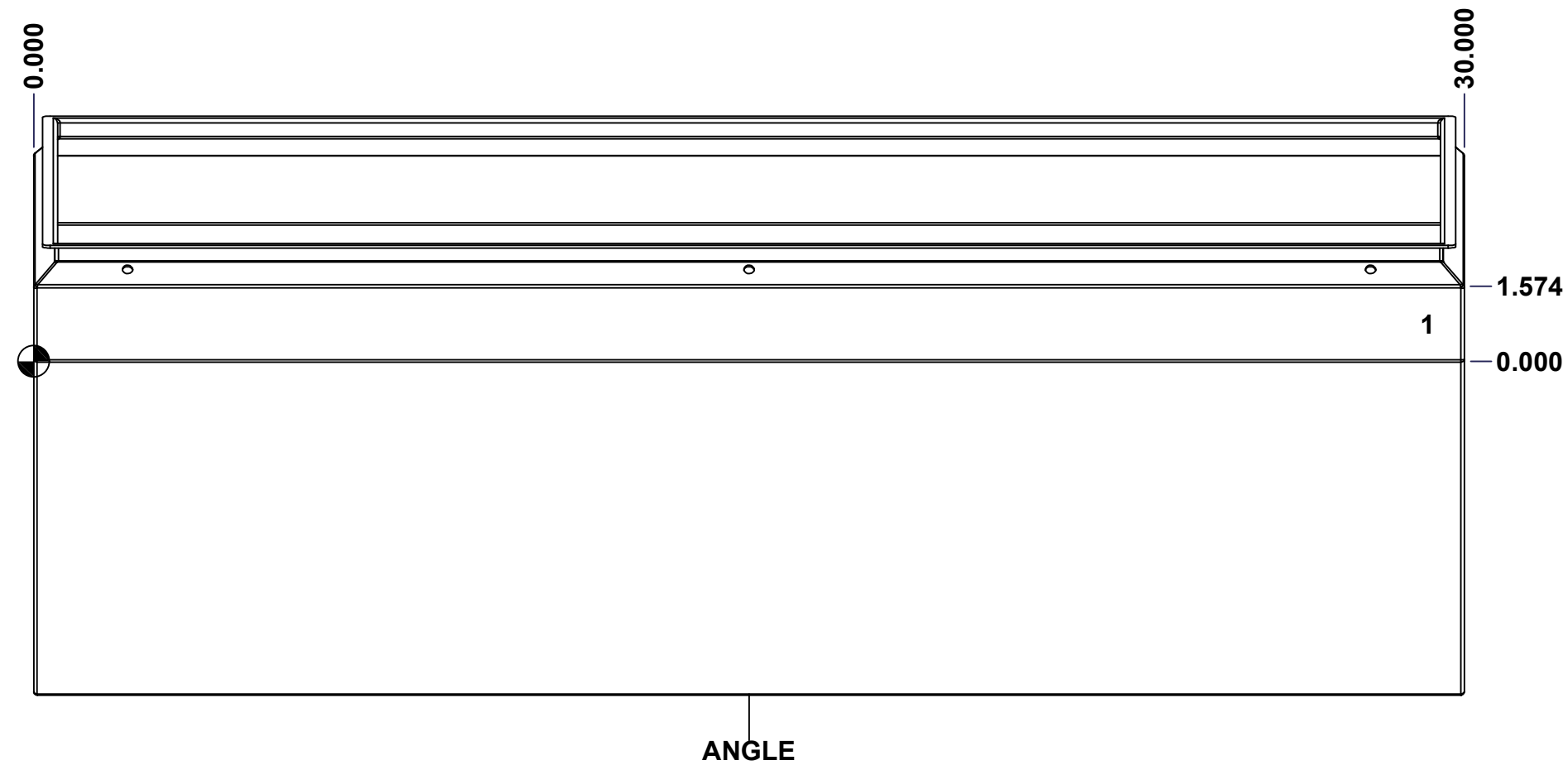

	Description	Status	
	1412CS 16" x 30" x 11.725" Body	(NULL)	
	Part Number Numéro Pièce	Rev.	7
	1412CS163011B	0	11

This drawing is confidential and must not be reproduced or used without the consent of EXM

Ce dessin est confidentiel et ne doit pas être reproduit ou utilisé sans le consentement de EXM

No.	Revisions	Date	By/Par

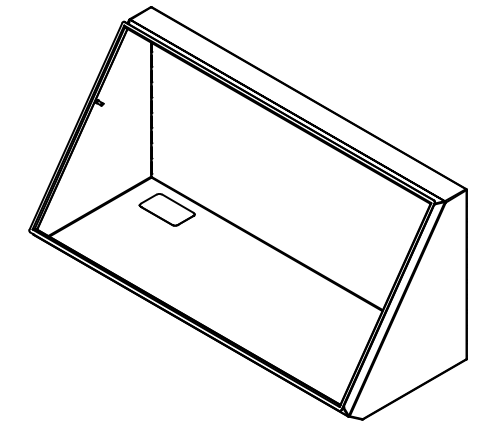

Isometric View



Tél: (450) 979-4373
 Fax: (450) 979-4626
www.exmweb.com

Flatness
Aplatissement

Max 3.0mm

Projection

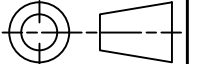

Customer Client	Date
Drawn By / Dessiné Par: BoxCad: BoxCad	Date: 1/21/2020
Material / Matière: 16 Ga Cold Rolled A1008 CS Type B (1.4mm)	
Color / Couleur: Asa-61 Grey	Finish / Fini: Smooth

Qty	Part_Number	Rev	Description
2	STK-Q-15033	0	Stud M5 x 12mm Steel
1	STK-Q-08350	5	Standoff M6 x 10mm
1	STK-S-00100	0	3.5" x 2" Silver Milar Flexcon Sticker
1	1412CS163011B-P	0	1412CS 16" x 30" x 11.725" Body Part
1	STK-P-02400S	0	Powder Paint (Asa-61 Grey / Smooth)

Description: 1412CS 16" x 30" x 11.725" Body	Detail Rev.
--	-------------

Part Number / Numéro Pièce: 1412CS163011B	Rev. 0	8
--	--------	---

Parts List

This drawing is confidential and must not be reproduced or used without the consent of EXM

Ce dessin est confidentiel et ne doit pas être reproduit ou utilisé sans le consentement de EXM



TOP

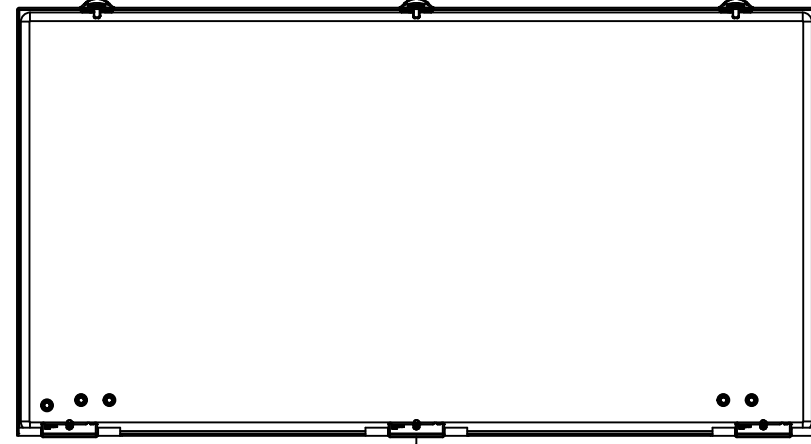

BACK

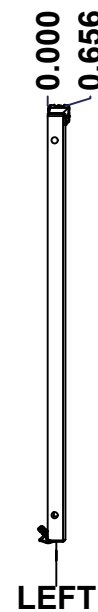

LEFT

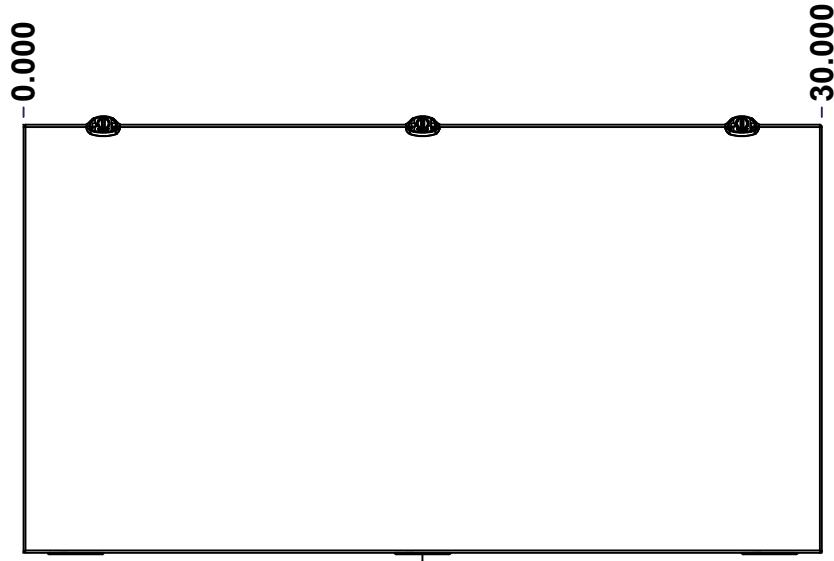

FRONT

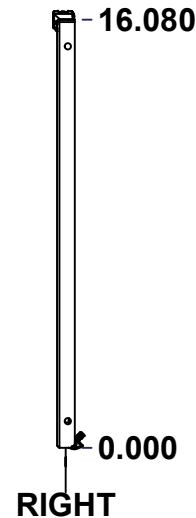

RIGHT



BOTTOM

No.	Revisions	Date	By/Par

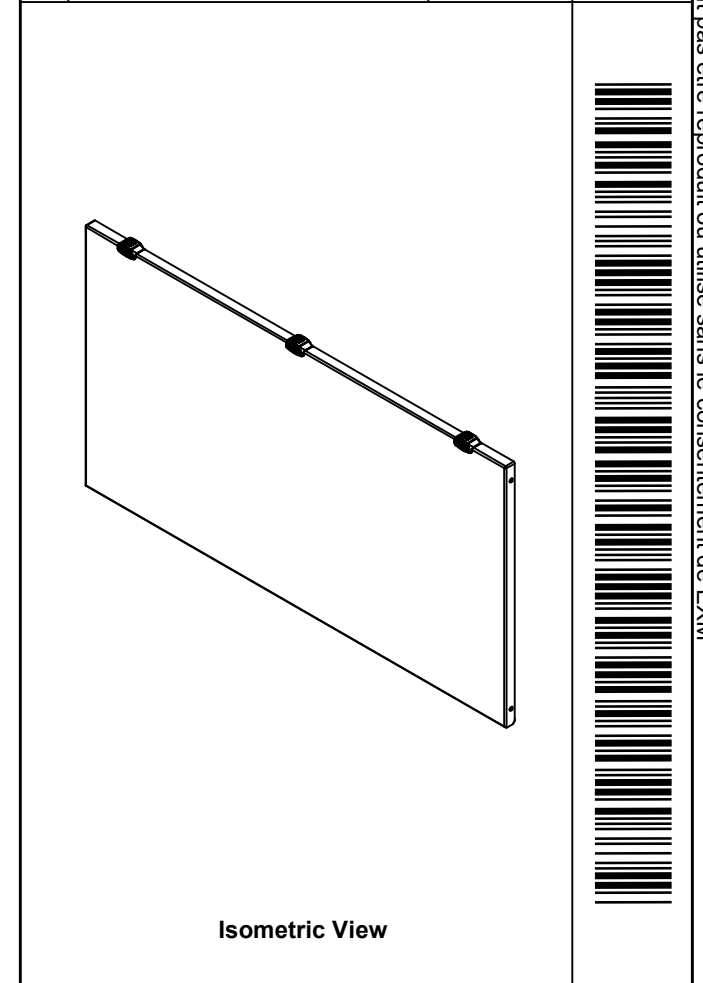

Isometric View



Tél: (450) 979-4373
 Fax: (450) 979-4626
www.exmweb.com

Flatness
 Aplatissement
 Max 3.0mm
 Projection

Customer Client	Date
Drawn By Dessiné Par BoxCad: BoxCad	Date 1/21/2020
Material Matière 16 Ga Cold Rolled A1008 CS Type B (1.4mm)	
Color Couleur Asa-61 Grey	Finish Fini Smooth
Description 1412CS 16" x 30" Cover	Detail Rev.
Part Number Numéro Pièce 1412CS163011C	Rev. 0

SEE BILL OF MATERIAL ON LAST PAGE

This drawing is confidential and must not be reproduced or used without the consent of EXM

Ce dessin est confidentiel et ne doit pas être reproduit ou utilisé sans le consentement de EXM

STANDARD FEATURES ARE NOT LISTED IN THIS HOLE TABLE

HOLE TABLE - FRONT VIEW (CUSTOM FEATURE ONLY)

CUT-OUT	XDIM	YDIM	DESCRIPTION
1	28.875	1.145	STANDOFF M6 x 10mm (Inside)
2	3.000	16.080	LOCK 880 SCQ2MS @ 90.0°
3	15.000	16.080	LOCK 880 SCQ2MS @ 90.0°
4	27.000	16.080	LOCK 880 SCQ2MS @ 90.0°
5	2.408	1.334	STANDOFF M6 x 10mm (Inside)
6	3.463	1.334	STANDOFF M6 x 10mm (Inside)
7	27.592	1.334	STANDOFF M6 x 10mm (Inside)
8	26.537	1.334	STANDOFF M6 x 10mm (Inside)

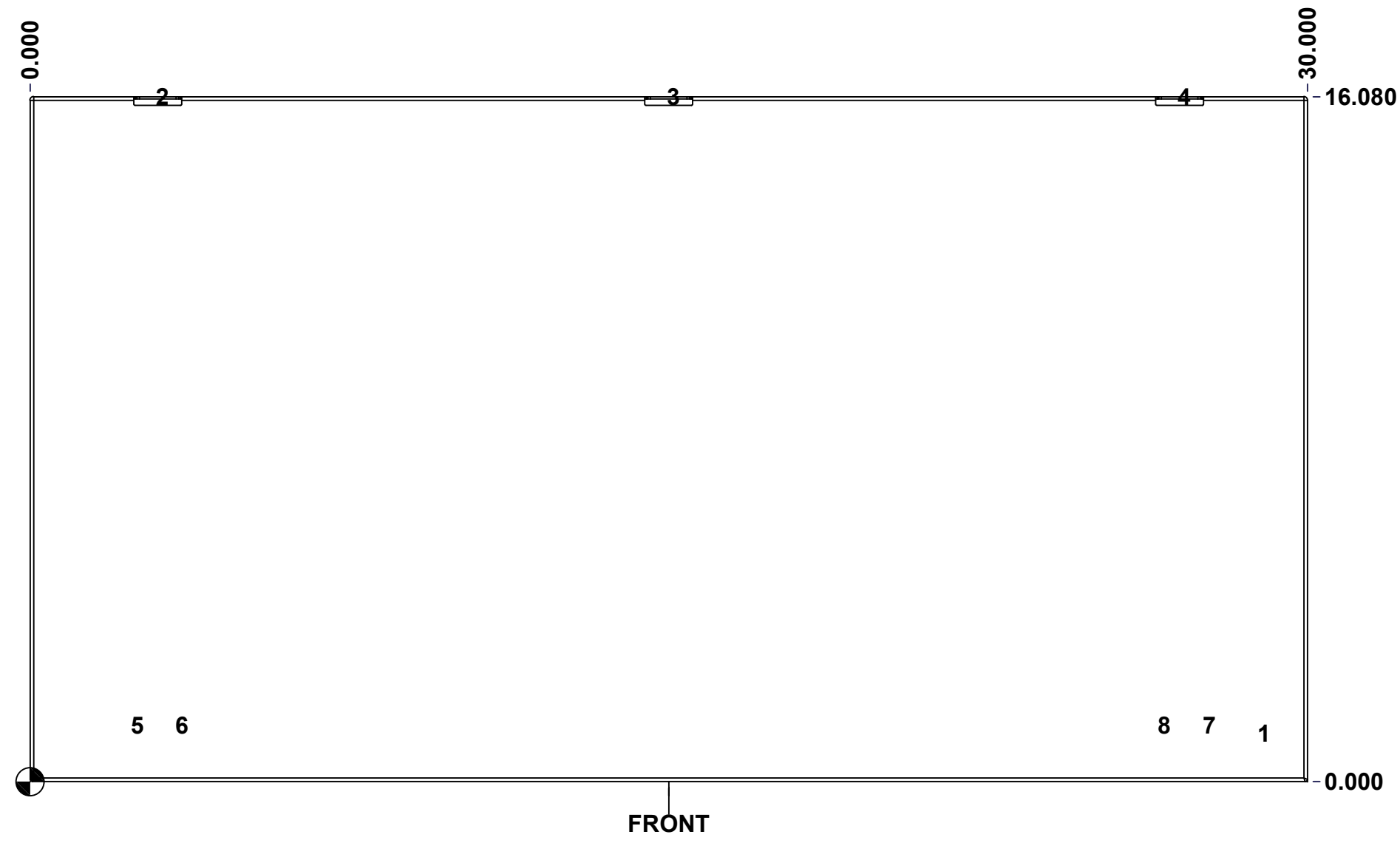



	Description	Status	
	1412CS 16" x 30" Cover	(NULL)	
	Part Number Numéro Pièce	Rev.	
	1412CS163011C	0	10 11

This drawing is confidential and must not be reproduced or used without the consent of EXM

Ce dessin est confidentiel et ne doit pas être reproduit ou utilisé sans le consentement de EXM

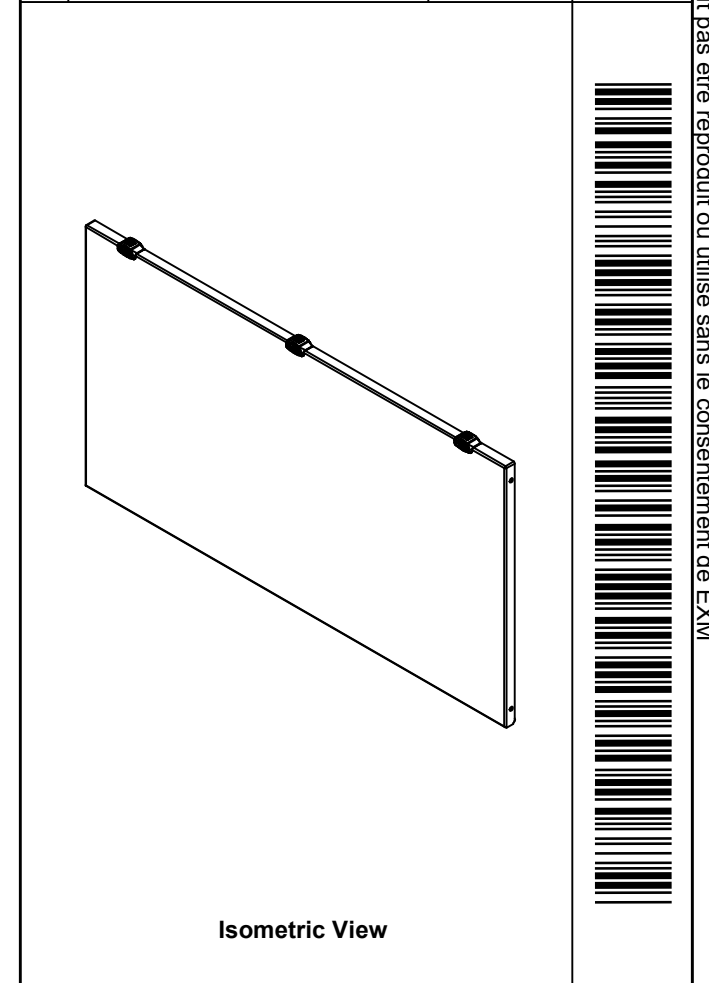
No.	Revisions	Date	By/Par

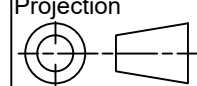

 Tél: (450) 979-4373 Fax: (450) 979-4626 www.exmweb.com		Flatness Aplatissement Max 3.0mm Projection 
Customer Client	Date	
Drawn By / Dessiné Par: BoxCad: BoxCad	Date: 1/21/2020	
Material / Matière: 16 Ga Cold Rolled A1008 CS Type B (1.4mm)		
Color / Couleur: Asa-61 Grey	Finish / Fini: Smooth	
Description: 1412CS 16" x 30" Cover		Detail Rev.
Part Number / Numéro Pièce: 1412CS163011C		Rev. 11
		0

Qty	Part Name	Rev	Description
5	STK-Q-08350	5	Standoff M6 x 10mm
1	STK-P-02400S	0	Powder Paint (Asa-61 Grey / Smooth)
1	1412CS163011G	0	1412CS 16" x 30" Gasket
1	1412CS163011C-P	0	1412CS 16" x 30" Cover Part
3	STK-A-33024	3	1100 MC Hinge
3	880SCQ2S	4	5412 ESMCH - External Lock Assy - Slot Lock
Parts List			