

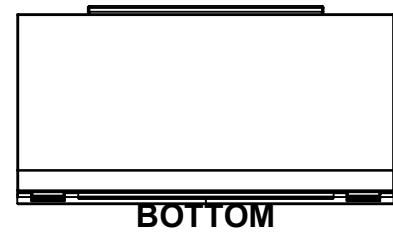

This drawing is confidential and must not be reproduced or used without the consent of EXM

Ce dessin est confidentiel et ne doit pas être reproduit ou utilisé sans le consentement de EXM

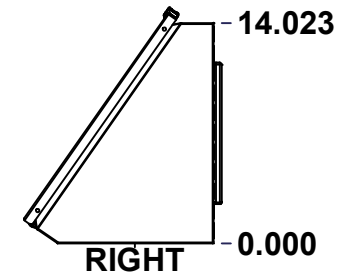
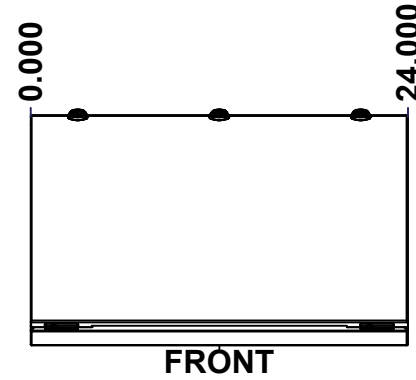
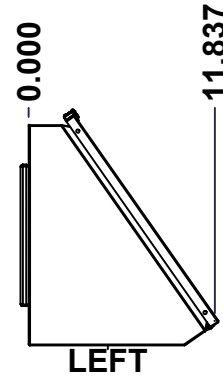
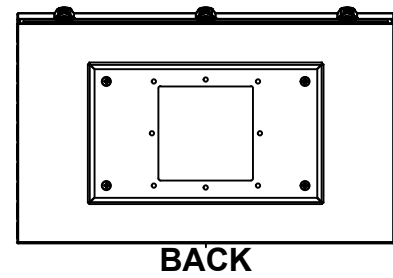
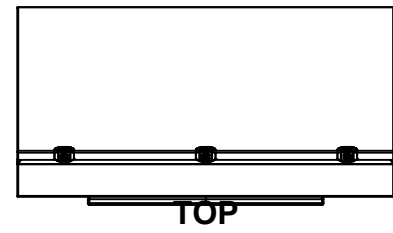
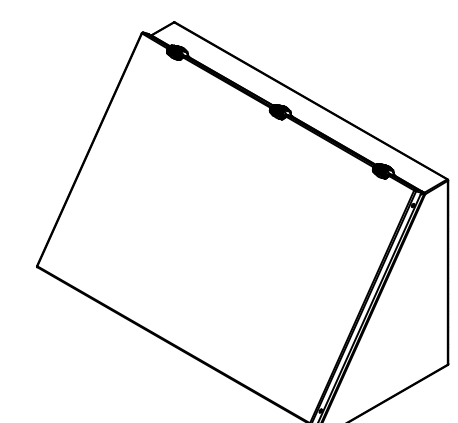

No.	Revisions	Date	By/Par

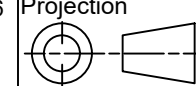

 Tél: (450) 979-4373 Fax: (450) 979-4626 www.exmweb.com		Flatness Aplatissement
		Max 3.0mm
Projection 		Date
Customer Client	BoxCad: BoxCad	Date 05-Dec-13
Material Matière	16 Ga Cold Rolled A1008 CS Type B (1.4mm)	
Color Couleur	Asa-61 Grey	Finish Fini Smooth
Description	1412CSE 16" x 24" x 11.725" Assembly	
Part Number Numéro Pièce	1412CSE162411	Rev. 1 0

SEE BILL OF MATERIAL ON LAST PAGE

This drawing is confidential and must not be reproduced or used without the consent of EXM

Ce dessin est confidentiel et ne doit pas être reproduit ou utilisé sans le consentement de EXM

NOTE	
ITEM	DESCRIPTION
1	NEMA 4, 12 Enclosure (IP66)
2	C/W Standard ground standoffs on box only
3	W/O Inner panel
4	W/O Inner panel mounting standoffs

No.	Revisions	Date	By/Par

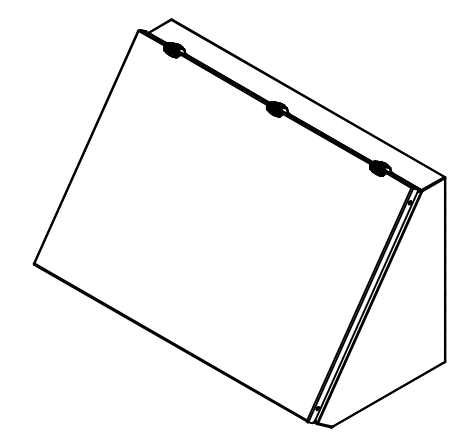

Isometric View

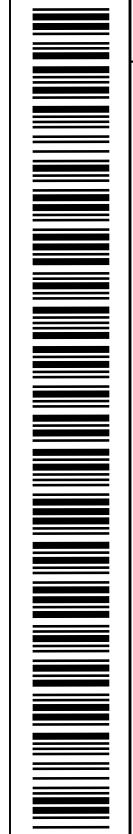

Tél: (450) 979-4373
 Fax: (450) 979-4626
www.exmweb.com

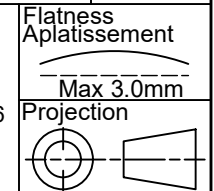

Customer Client	Date
Drawn By / Dessiné Par: BoxCad: BoxCad	Date: 05-Dec-13
Material / Matière: 16 Ga Cold Rolled A1008 CS Type B (1.4mm)	

Color / Couleur: Asa-61 Grey	Finish / Fini: Smooth
Description: 1412CSE 16" x 24" x 11.725" Assembly	Detail Rev.
Part Number / Numéro Pièce: 1412CSE162411	Rev. 0

PACKING		
ITEM	QTY	DESCRIPTION
Cardboard sleeve	2	Top and Bottom
Cardboard strip	2	Between back of enclosure and inner panel
Plastic bag	1	To protect cover surface and inside gasket
Plastic strap - Black	2	To Squeeze the 2 cardboard sleeve together
Packaging label	1	White label with product number

Qty	Part Number	Rev	Description
1	1412CSE162411C	0	1412CSE 16" x 24" Cover
1	1412CSE162411B	0	1412CSE 16" x 24" x 11.725" Body
2	880 GS115	1	Gas Spring 115N/12Kg/26Lbs
2	STK-Q-08126	1	M5 Stainless Steel 316 Nylon Insert Lock Nut with Incorporated Sealing Washer

Parts List

This drawing is confidential and must not be reproduced or used without the consent of EXM

Ce dessin est confidentiel et ne doit pas être reproduit ou utilisé sans le consentement de EXM

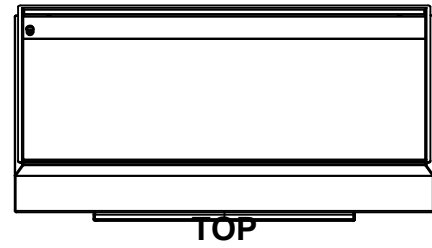

TOP

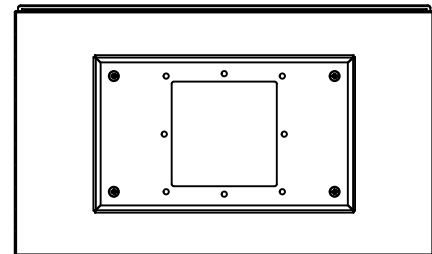

BACK

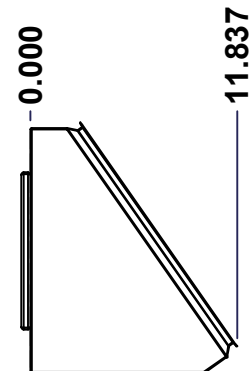

LEFT

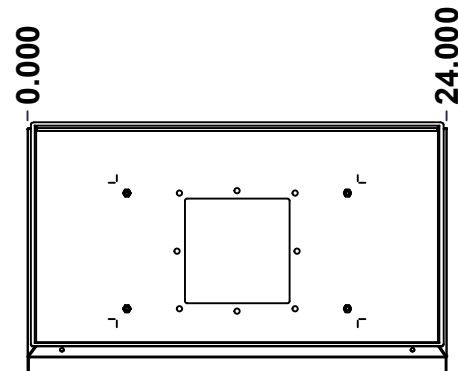

FRONT

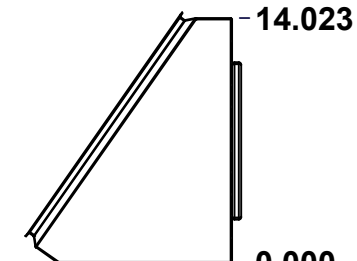

RIGHT

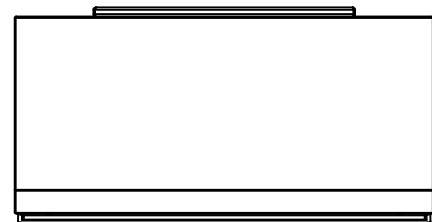

BOTTOM

No.	Revisions	Date	By/Par

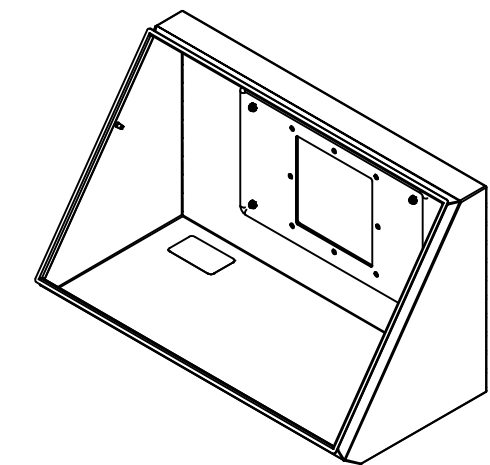

Isometric View

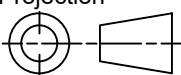

 Tél: (450) 979-4373 Fax: (450) 979-4626 www.exmweb.com		Flatness Aplatissement Max 3.0mm Projection 
Customer Client	Date	
Drawn By Dessiné Par	BoxCad: BoxCad	Date 05-Dec-13
Material Matière	16 Ga Cold Rolled A1008 CS Type B (1.4mm)	
Color Couleur	Asa-61 Grey	Finish Fini Smooth
Description	Detail Rev.	
1412CSE 16" x 24" x 11.725" Body		
Part Number Numéro Pièce	Rev.	3
1412CSE162411B	0	11

SEE BILL OF MATERIAL ON LAST PAGE

This drawing is confidential and must not be reproduced or used without the consent of EXM

Ce dessin est confidentiel et ne doit pas être reproduit ou utilisé sans le consentement de EXM

STANDARD FEATURES ARE NOT LISTED IN THIS HOLE TABLE			
HOLE TABLE - RIGHT VIEW (CUSTOM FEATURE ONLY)			
CUT-OUT	XDIM	YDIM	DESCRIPTION
1	5.205	8.839	STUDSM6 x 10mm (Inside)

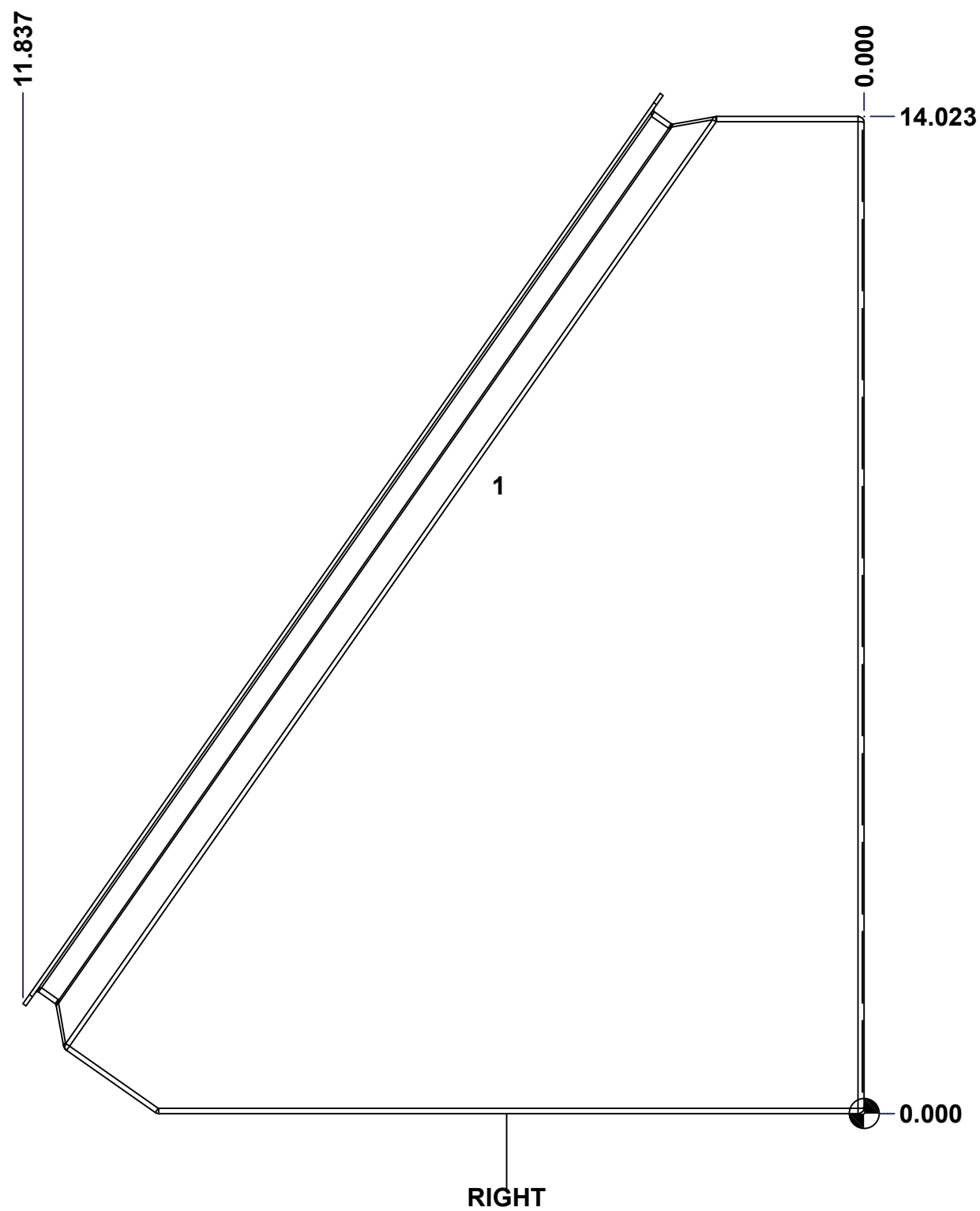

	Description	Status	
	1412CSE 16" x 24" x 11.725" Body	(NULL)	
	Part Number Numéro Pièce	Rev.	
	1412CSE162411B	0	4
			11

This drawing is confidential and must not be reproduced or used without the consent of EXM

Ce dessin est confidentiel et ne doit pas être reproduit ou utilisé sans le consentement de EXM

STANDARD FEATURES ARE NOT LISTED IN THIS HOLE TABLE

HOLE TABLE - BOTTOM VIEW (CUSTOM FEATURE ONLY)

CUT-OUT	XDIM	YDIM	DESCRIPTION
1	3.500	2.000	LABEL_EXM (Inside)



	Description	Status	
	1412CSE 16" x 24" x 11.725" Body	(NULL)	
	Part Number Numéro Pièce	Rev.	5
	1412CSE162411B	0	11

This drawing is confidential and must not be reproduced or used without the consent of EXM

Ce dessin est confidentiel et ne doit pas être reproduit ou utilisé sans le consentement de EXM

STANDARD FEATURES ARE NOT LISTED IN THIS HOLE TABLE			
HOLE TABLE - LEFT VIEW (CUSTOM FEATURE ONLY)			
CUT-OUT	XDIM	YDIM	DESCRIPTION
1	5.205	8.839	STUDSM6 x 10mm (Inside)

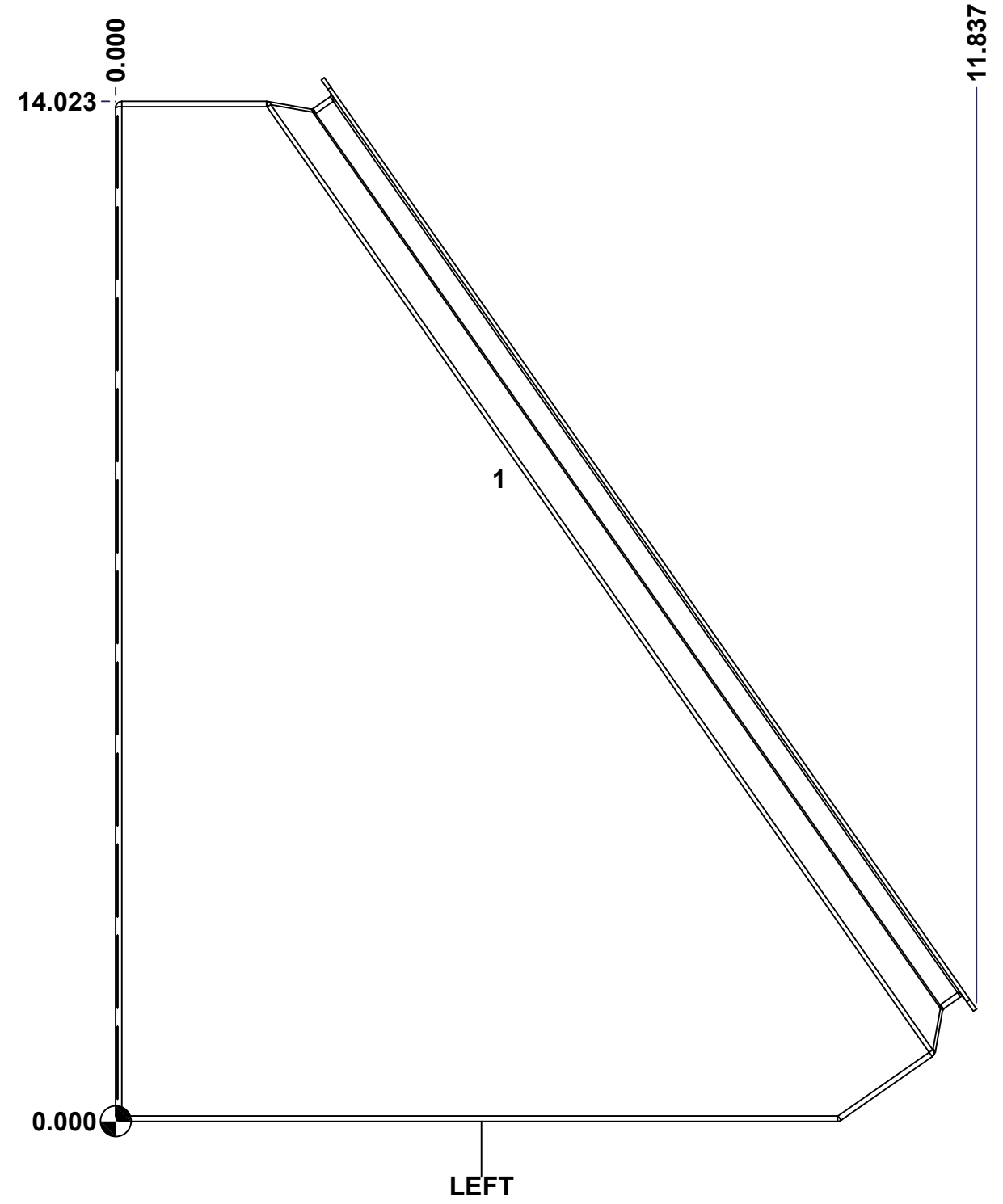

	Description	Status	
	1412CSE 16" x 24" x 11.725" Body	(NULL)	
	Part Number Numéro Pièce	Rev.	6
	1412CSE162411B	0	11

This drawing is confidential and must not be reproduced or used without the consent of EXM

Ce dessin est confidentiel et ne doit pas être reproduit ou utilisé sans le consentement de EXM

STANDARD FEATURES ARE NOT LISTED IN THIS HOLE TABLE			
HOLE TABLE - ANGLE VIEW (CUSTOM FEATURE ONLY)			
CUT-OUT	XDIM	YDIM	DESCRIPTION
1	23.125	0.742	STANDOFF M6 x 10mm (Inside)

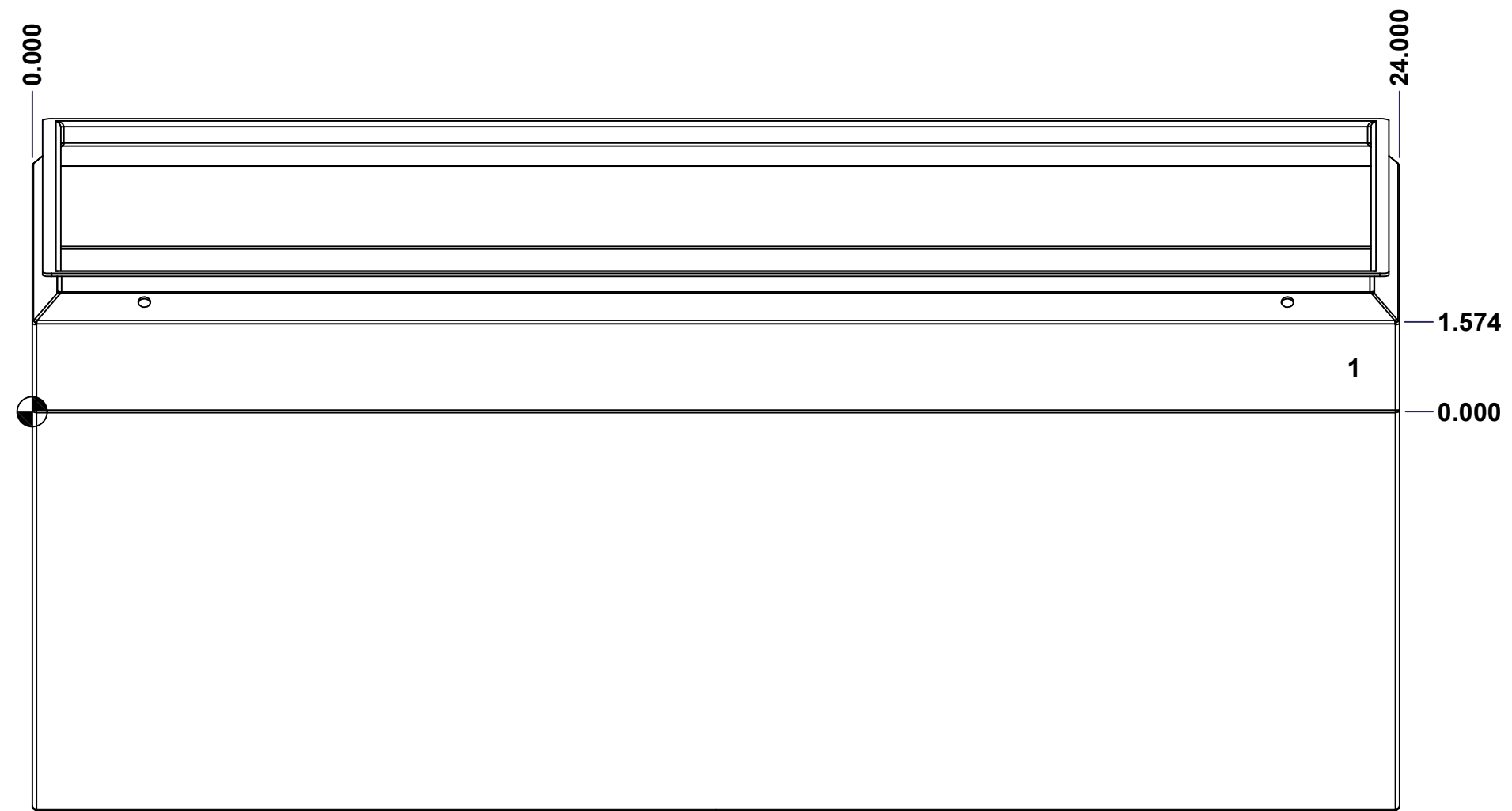

ANGLE

	Description	Status	
	1412CSE 16" x 24" x 11.725" Body	(NULL)	
	Part Number Numéro Pièce	Rev.	7
	1412CSE162411B	0	11

This drawing is confidential and must not be reproduced or used without the consent of EXM

Ce dessin est confidentiel et ne doit pas être reproduit ou utilisé sans le consentement de EXM

No.	Revisions	Date	By/Par

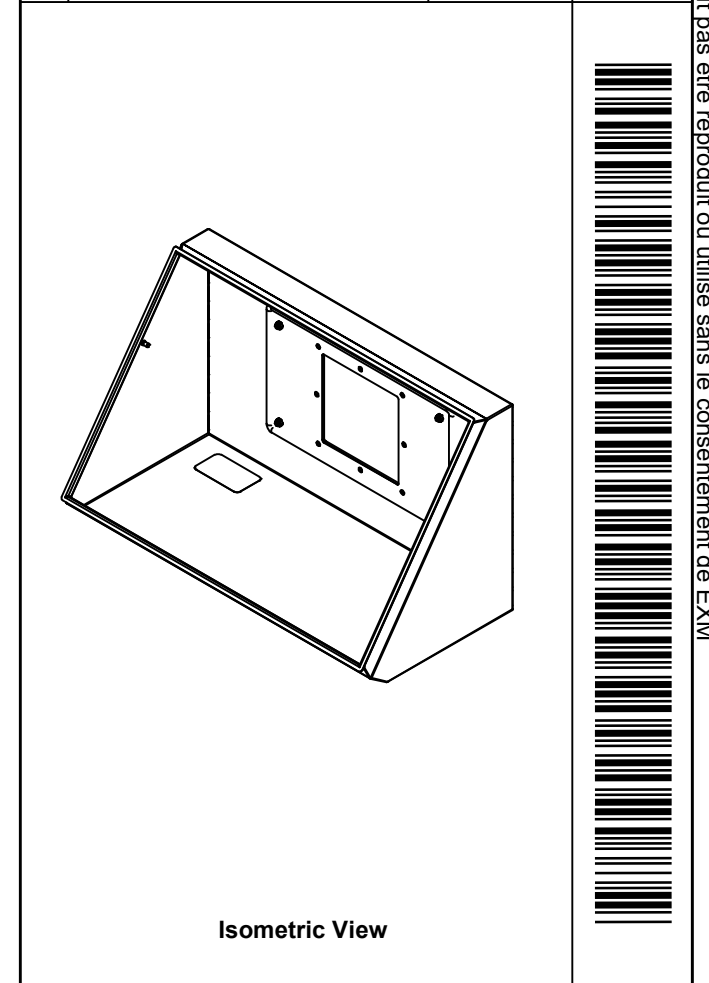

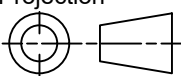
 Tél: (450) 979-4373 Fax: (450) 979-4626 www.exmweb.com		Flatness Aplatissement Max 3.0mm Projection 	
Customer Client		Date	
Drawn By / Dessiné Par: BoxCad: BoxCad		Date: 05-Dec-13	
Material / Matière: 16 Ga Cold Rolled A1008 CS Type B (1.4mm)			
Color / Couleur: Asa-61 Grey		Finish / Fini: Smooth	
Description: 1412CSE 16" x 24" x 11.725" Body			Detail Rev.
Part Number / Numéro Pièce: 1412CSE162411B			Rev. 8
			11

Qty	Part_Number	Rev	Description
2	STK-Q-16030	0	Stud M6 x 10mm Steel
1	STK-S-00100	0	3.5" x 2" Silver Milar Flexcon Sticker
1	STK-Q-08350	5	Standoff M6 x 10mm
1	STK-P-02400S	0	Powder Paint (Asa-61 Grey / Smooth)
1	1412CSE162411B-P	0	1412CSE 16" x 24" x 11.725" Body Part
1	1500CS_SUP	0	1500CS - Support Plate Part
Parts List			

This drawing is confidential and must not be reproduced or used without the consent of EXM

Ce dessin est confidentiel et ne doit pas être reproduit ou utilisé sans le consentement de EXM



TOP

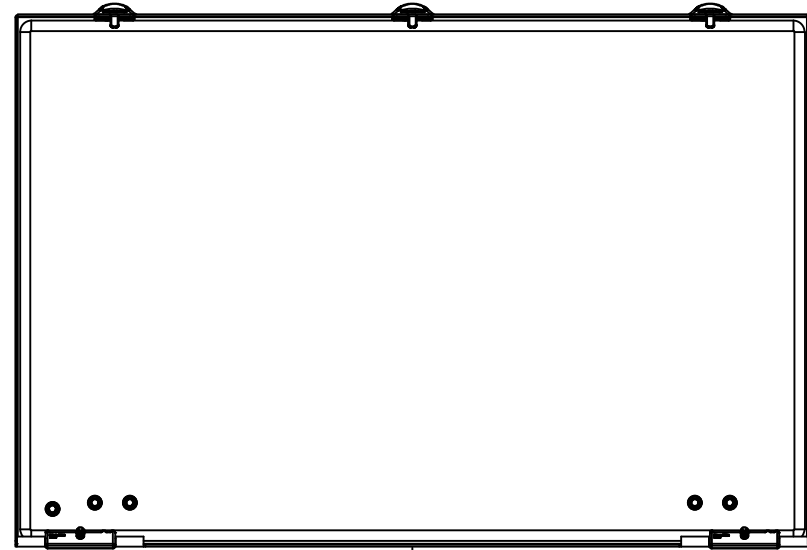

BACK

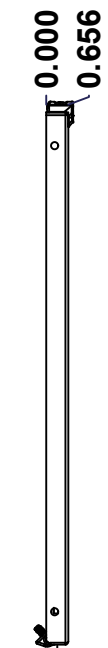

LEFT

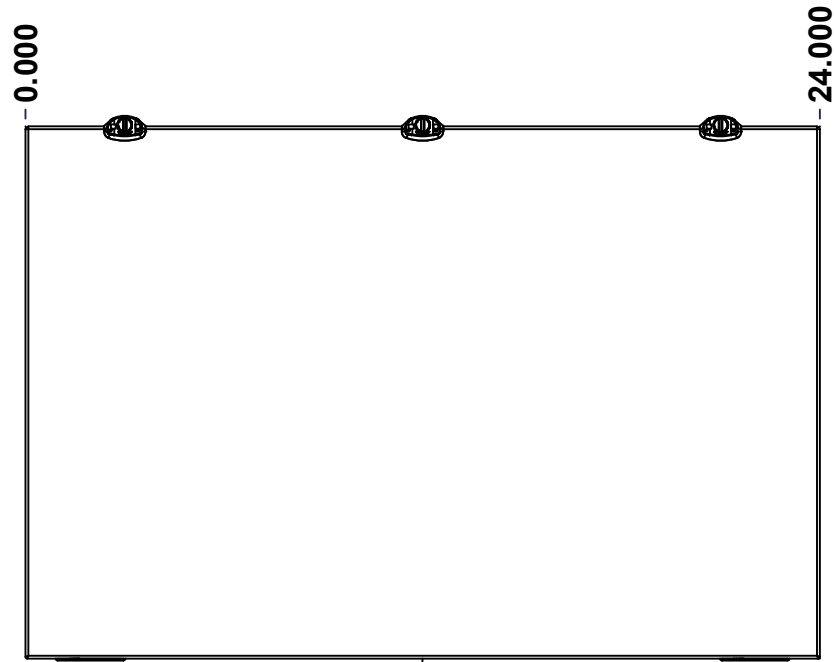

FRONT

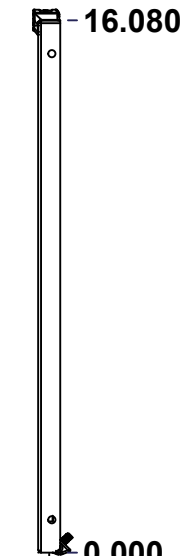



RIGHT

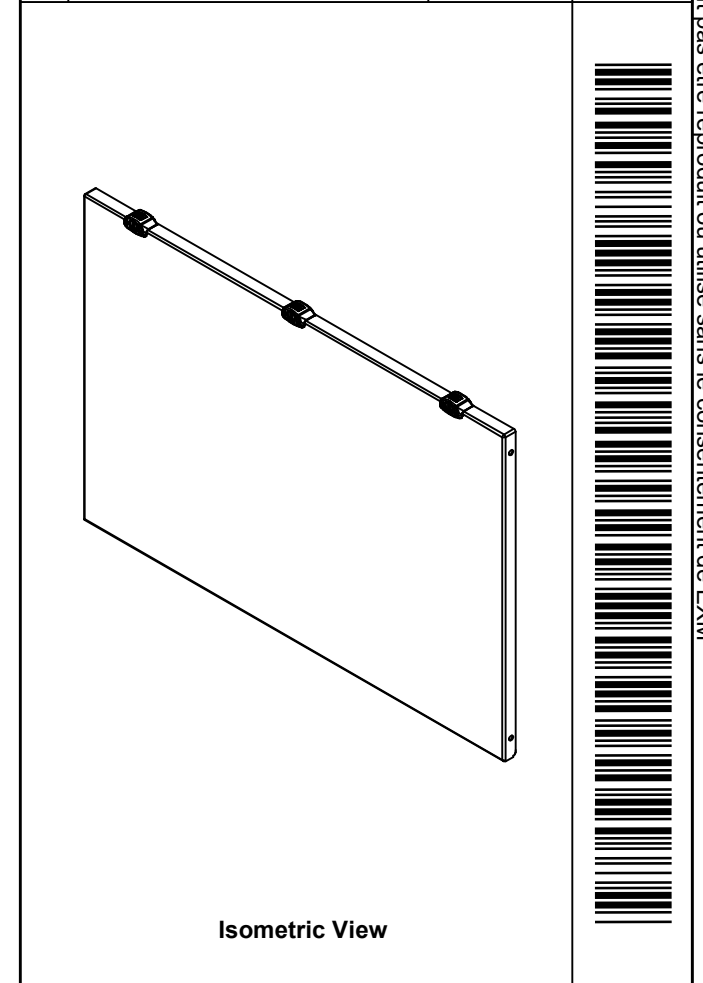

BOTTOM

No.	Revisions	Date	By/Par



 Tél: (450) 979-4373 Fax: (450) 979-4626 www.exmweb.com		Flatness Aplatissement
		Max 3.0mm
Customer Client		Date
Drawn By Dessiné Par BoxCad: BoxCad		Date 05-Dec-13
Material Matière 16 Ga Cold Rolled A1008 CS Type B (1.4mm)		
Color Couleur	Asa-61 Grey	Finish Fini Smooth
Description 1412CSE 16" x 24" Cover		Detail Rev.
Part Number Numéro Pièce 1412CSE162411C		Rev. 9
SEE BILL OF MATERIAL ON LAST PAGE		0

This drawing is confidential and must not be reproduced or used without the consent of EXM

Ce dessin est confidentiel et ne doit pas être reproduit ou utilisé sans le consentement de EXM

STANDARD FEATURES ARE NOT LISTED IN THIS HOLE TABLE

HOLE TABLE - FRONT VIEW (CUSTOM FEATURE ONLY)

CUT-OUT	XDIM	YDIM	DESCRIPTION
1	3.000	16.080	LOCK 880 SCQ2MS @ 90.0°
2	12.000	16.080	LOCK 880 SCQ2MS @ 90.0°
3	21.000	16.080	LOCK 880 SCQ2MS @ 90.0°
4	22.875	1.145	STANDOFF M6 x 10mm (Inside)
5	2.408	1.334	STANDOFF M6 x 10mm (Inside)
6	3.463	1.334	STANDOFF M6 x 10mm (Inside)
7	21.592	1.334	STANDOFF M6 x 10mm (Inside)
8	20.537	1.334	STANDOFF M6 x 10mm (Inside)

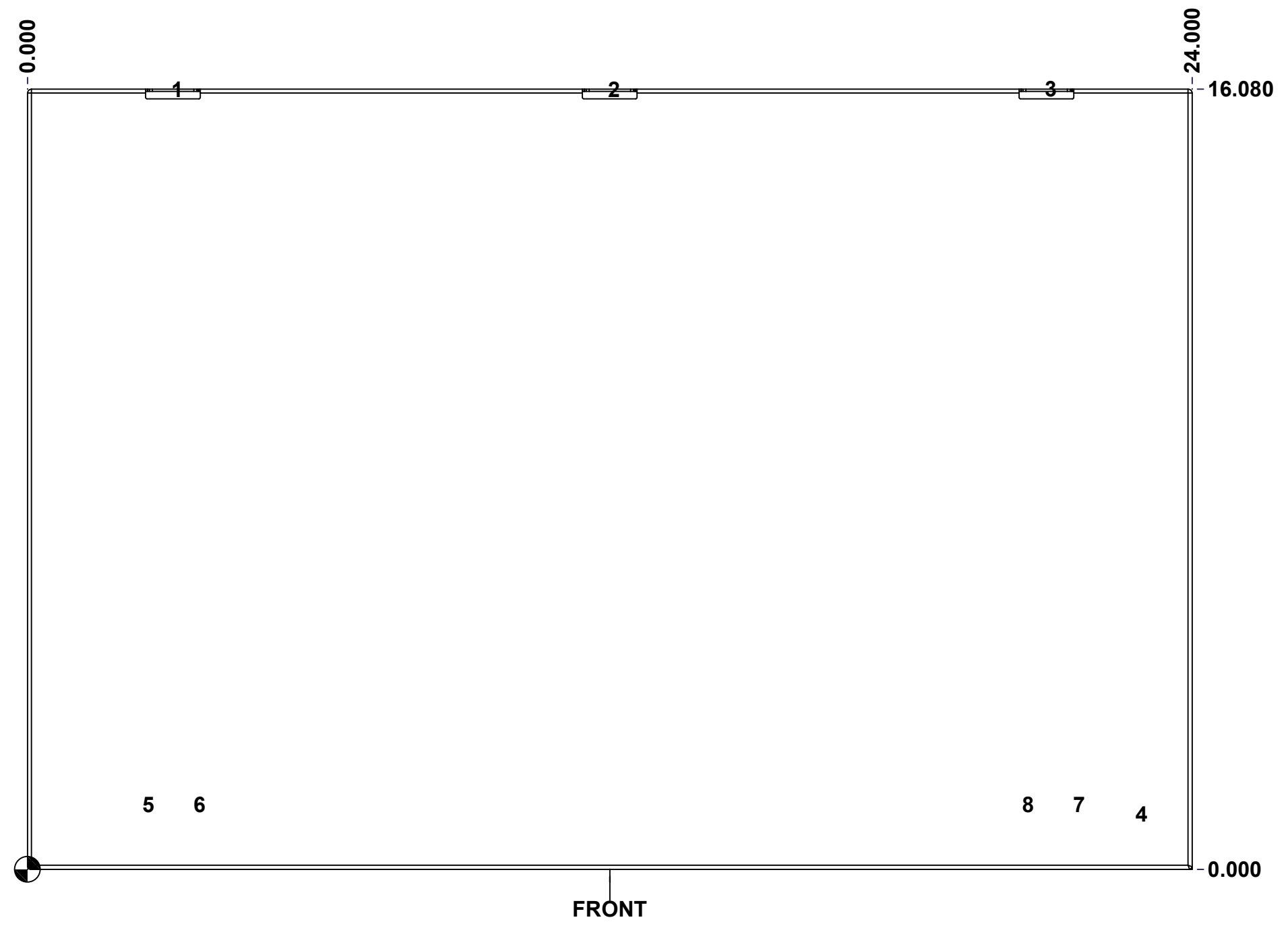



	Description	Status	
	1412CSE 16" x 24" Cover	(NULL)	
	Part Number Numéro Pièce	Rev.	10
	1412CSE162411C	0	11

This drawing is confidential and must not be reproduced or used without the consent of EXM

Ce dessin est confidentiel et ne doit pas être reproduit ou utilisé sans le consentement de EXM

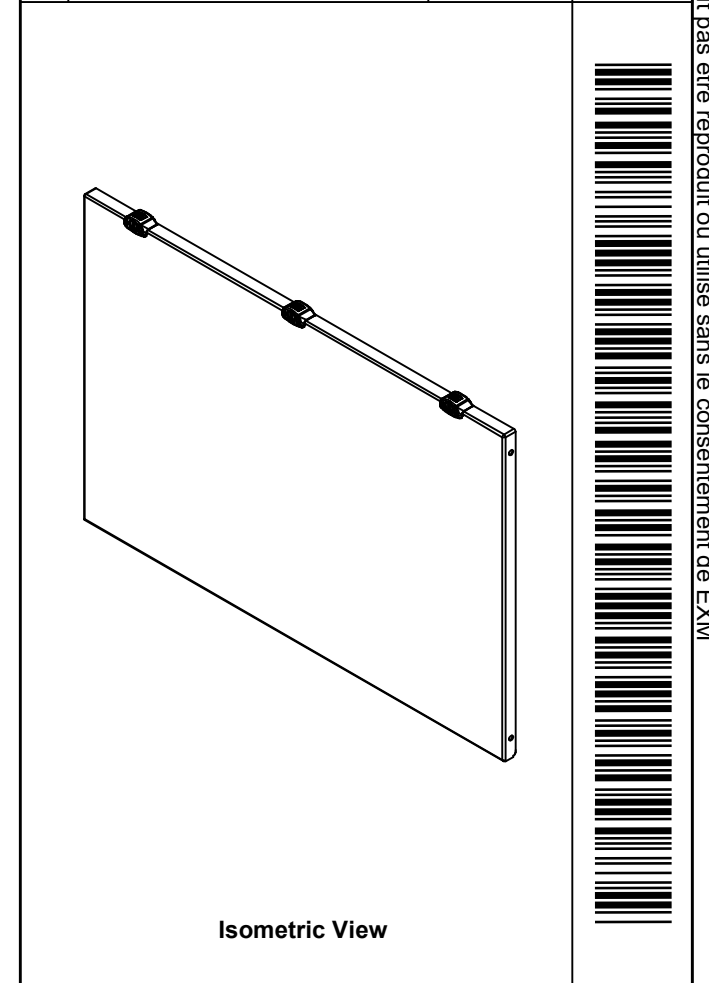
No.	Revisions	Date	By/Par

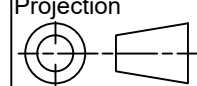

 Tél: (450) 979-4373 Fax: (450) 979-4626 www.exmweb.com		Flatness Aplatissement Max 3.0mm Projection 
Customer Client	Date	
Drawn By / Dessiné Par: BoxCad: BoxCad	Date: 05-Dec-13	
Material / Matière: 16 Ga Cold Rolled A1008 CS Type B (1.4mm)		
Color / Couleur: Asa-61 Grey	Finish / Fini: Smooth	
Description: 1412CSE 16" x 24" Cover		Detail Rev.
Part Number / Numéro Pièce: 1412CSE162411C	Rev.:	11
		0

Qty	Part Name	Rev	Description
5	STK-Q-08350	5	Standoff M6 x 10mm
1	STK-P-02400S	0	Powder Paint (Asa-61 Grey / Smooth)
1	1412CSE162411G	0	1412CSE 16" x 24" Gasket
1	1412CSE162411C-P	0	1412CSE 16" x 24" Cover Part
2	STK-A-33024	3	1100 MC Hinge
3	STK-A-79960	14	5412 ESMCH - External Lock Assy - Slot Lock
Parts List			