

This drawing is confidential and must not be reproduced or used without the consent of EXM

Ce dessin est confidentiel et ne doit pas être reproduit ou utilisé sans le consentement de EXM

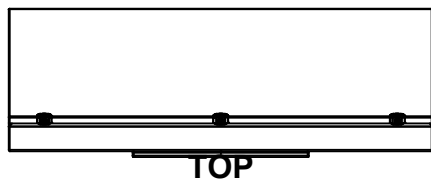

TOP

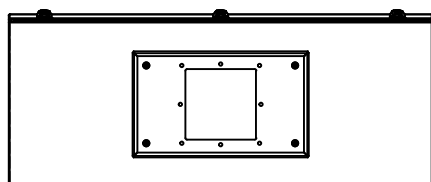

BACK

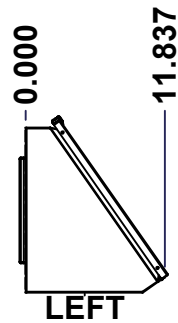

LEFT

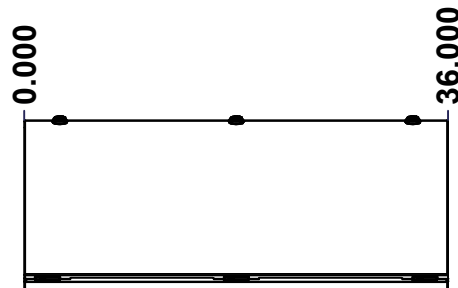

FRONT

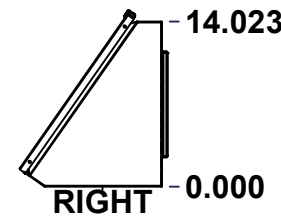

RIGHT

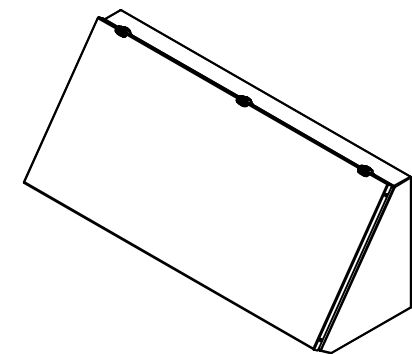

Isometric View



BOTTOM

No.	Revisions	Date	By/Par

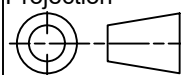
 Tél: (450) 979-4373 Fax: (450) 979-4626 www.exmweb.com		Flatness Aplatissement Max 3.0mm Projection 
Customer Client	Date	
Drawn By Dessiné Par	BoxCad: BoxCad	Date 05-Dec-13
Material Matière	16 Ga Cold Rolled A1008 CS Type B (1.4mm)	
Color Couleur	Asa-61 Grey	Finish Fini Textured
Description 1412CSE 16" x 36" x 11.725" Assembly		Detail Rev.
Part Number Numéro Pièce	1412CSE163611	Rev. 1 0

SEE BILL OF MATERIAL ON LAST PAGE

This drawing is confidential and must not be reproduced or used without the consent of EXM

Ce dessin est confidentiel et ne doit pas être reproduit ou utilisé sans le consentement de EXM

NOTE	
ITEM	DESCRIPTION
1	NEMA 4, 12 Enclosure (IP66)
2	C/W Standard ground standoffs on box only
3	W/O Inner panel
4	W/O Inner panel mounting standoffs

No.	Revisions	Date	By/Par

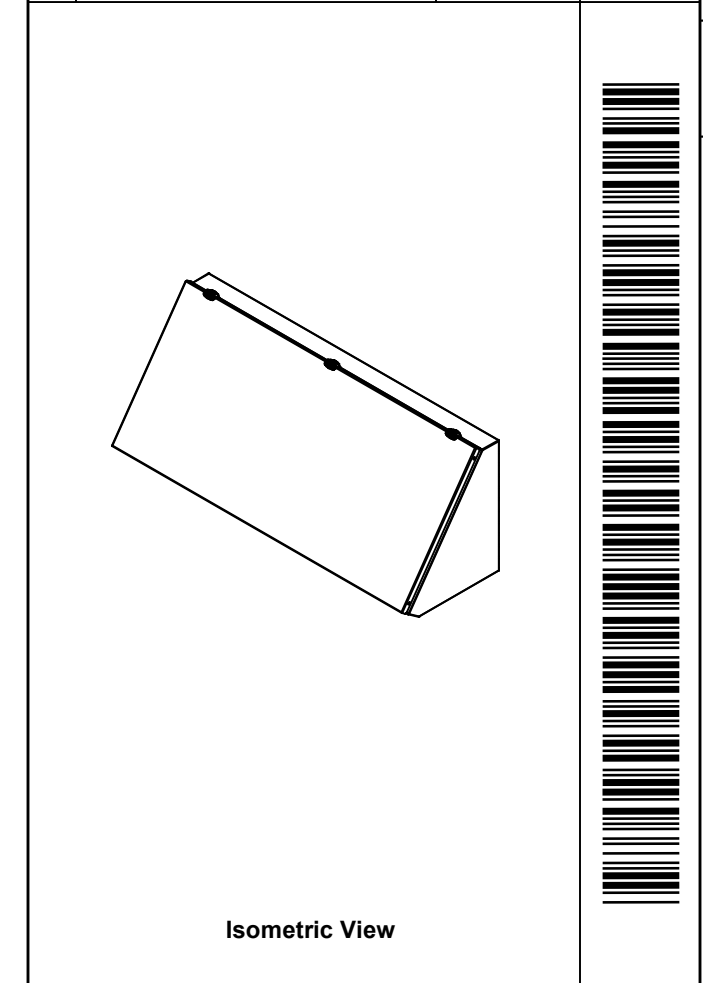

Tél: (450) 979-4373 Fax: (450) 979-4626 www.exmweb.com		Flatness Aplatissement Max 3.0mm Projection
Customer Client	Date	
Drawn By Dessiné Par	BoxCad: BoxCad	Date 05-Dec-13
Material Matière	16 Ga Cold Rolled A1008 CS Type B (1.4mm)	
Color Couleur	Asa-61 Grey	Finish Fini Textured
Description	1412CSE 16" x 36" x 11.725" Assembly	
Part Number Numéro Pièce	1412CSE163611	
Rev.	2	11

PACKING		
ITEM	QTY	DESCRIPTION
Cardboard sleeve	2	Top and Bottom
Cardboard strip	2	Between back of enclosure and inner panel
Plastic bag	1	To protect cover surface and inside gasket
Plastic strap - Black	2	To Squeeze the 2 cardboard sleeve together
Packaging label	1	White label with product number

1	1412CSE163611C	0	1412CSE 16" x 36" Cover
1	1412CSE163611B	0	1412CSE 16" x 36" x 11.725" Body
2	880 GS115	1	Gas Spring 115N/12Kg/26Lbs
3	STK-A-08126	0	M5 Stainless Steel 316 Nylon Insert Lock Nut with Incorporated Sealing Washer
Qty	Part Number	Rev	Description
Parts List			

This drawing is confidential and must not be reproduced or used without the consent of EXM

Ce dessin est confidentiel et ne doit pas être reproduit ou utilisé sans le consentement de EXM

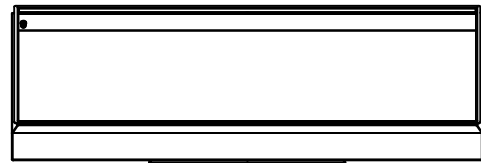

TOP

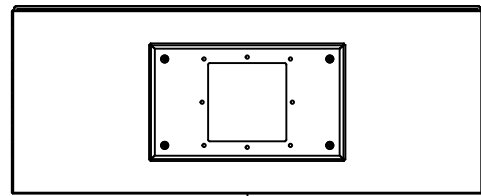

BACK

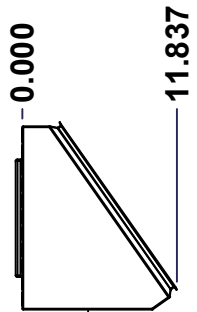

LEFT

0.000
11.837

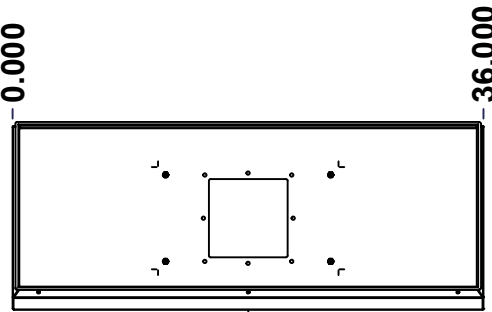

FRONT

0.000
36.000

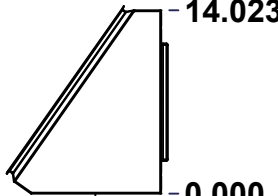

RIGHT

14.023
0.000



BOTTOM

No.	Revisions	Date	By/Par

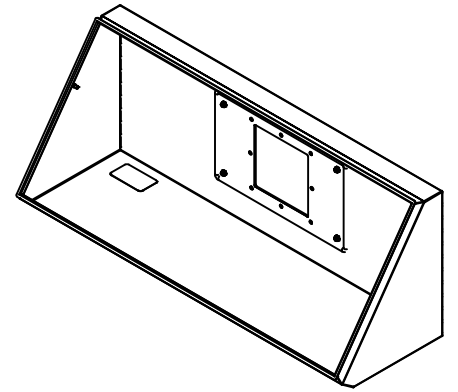

Isometric View



Tél: (450) 979-4373
Fax: (450) 979-4626
www.exmweb.com

Flatness
Aplatissement
Max 3.0mm
Projection

Customer Client	Date
Drawn By / Dessiné Par: BoxCad: BoxCad	Date: 05-Dec-13
Material / Matière: 16 Ga Cold Rolled A1008 CS Type B (1.4mm)	

Color / Couleur: Asa-61 Grey	Finish / Fini: Textured
------------------------------	-------------------------

Description: 1412CSE 16" x 36" x 11.725" Body	Detail Rev.
---	-------------

Part Number / Numéro Pièce: 1412CSE163611B	Rev. 0	3	11
---	--------	---	----

SEE BILL OF MATERIAL ON LAST PAGE

This drawing is confidential and must not be reproduced or used without the consent of EXM

Ce dessin est confidentiel et ne doit pas être reproduit ou utilisé sans le consentement de EXM

STANDARD FEATURES ARE NOT LISTED IN THIS HOLE TABLE			
HOLE TABLE - RIGHT VIEW (CUSTOM FEATURE ONLY)			
CUT-OUT	XDIM	YDIM	DESCRIPTION
1	5.205	8.839	STUDS M6 x 10mm (Inside)

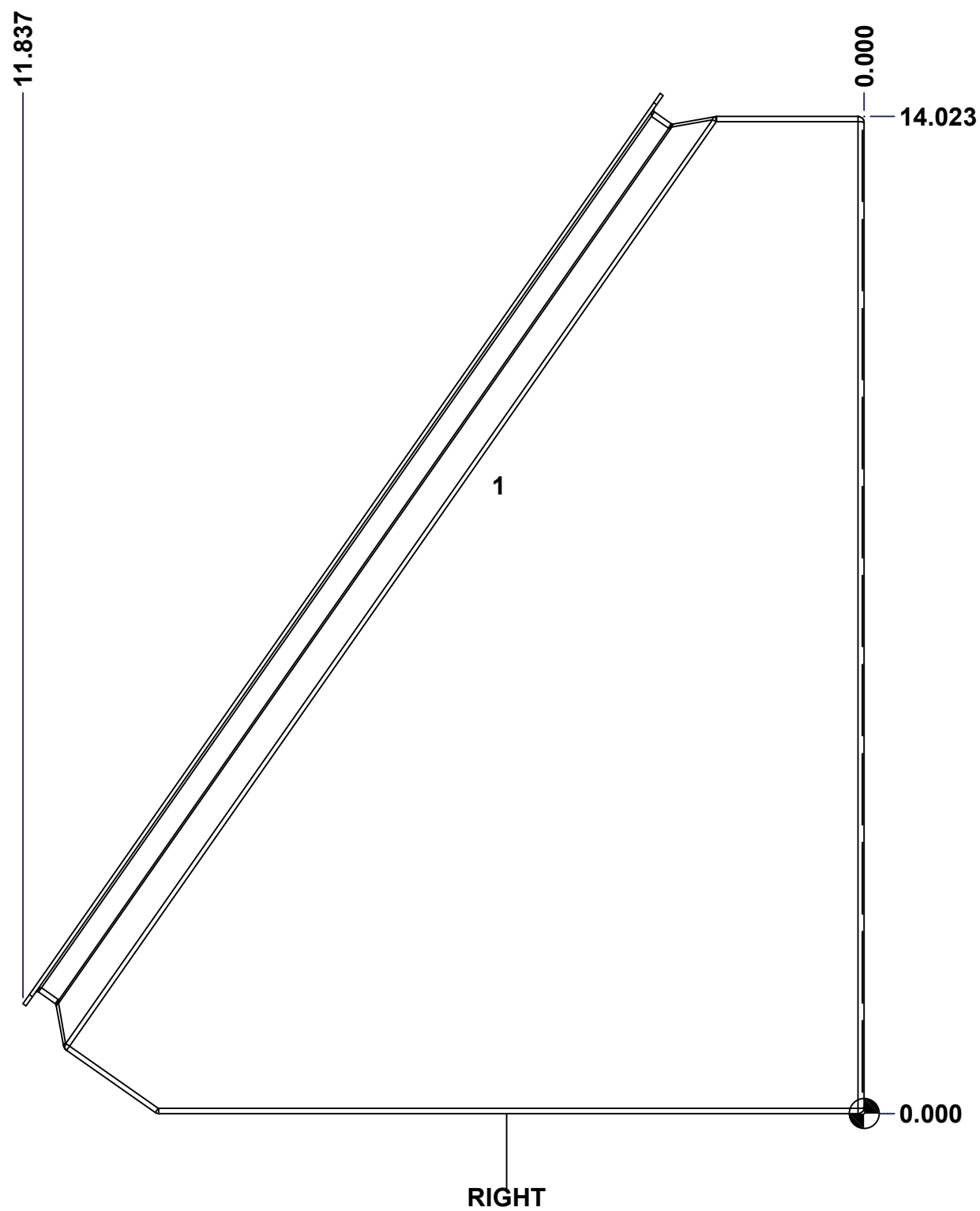

	Description	Status	
	1412CSE 16" x 36" x 11.725" Body	(NULL)	
Part Number Numéro Pièce	1412CSE163611B	Rev.	4
		0	11

This drawing is confidential and must not be reproduced or used without the consent of EXM

Ce dessin est confidentiel et ne doit pas être reproduit ou utilisé sans le consentement de EXM

STANDARD FEATURES ARE NOT LISTED IN THIS HOLE TABLE			
HOLE TABLE - BOTTOM VIEW (CUSTOM FEATURE ONLY)			
CUT-OUT	XDIM	YDIM	DESCRIPTION
1	3.500	2.000	LABEL_EXM (Inside)

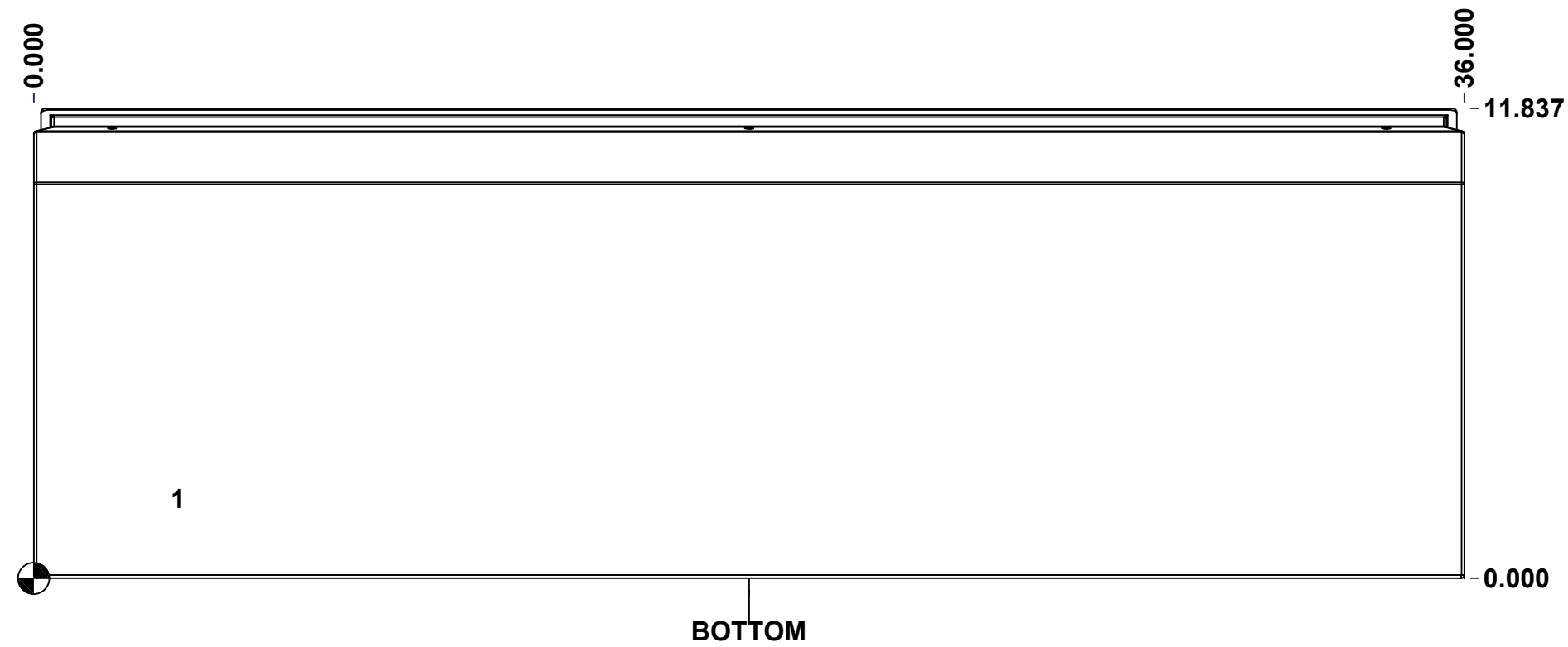

	Description		Status
	1412CSE 16" x 36" x 11.725" Body		(NULL)
	Part Number Numéro Pièce		Rev.
	1412CSE163611B		0 / 5
			11

This drawing is confidential and must not be reproduced or used without the consent of EXM

Ce dessin est confidentiel et ne doit pas être reproduit ou utilisé sans le consentement de EXM

STANDARD FEATURES ARE NOT LISTED IN THIS HOLE TABLE			
HOLE TABLE - LEFT VIEW (CUSTOM FEATURE ONLY)			
CUT-OUT	XDIM	YDIM	DESCRIPTION
1	5.205	8.839	STUDS M6 x 10mm (Inside)

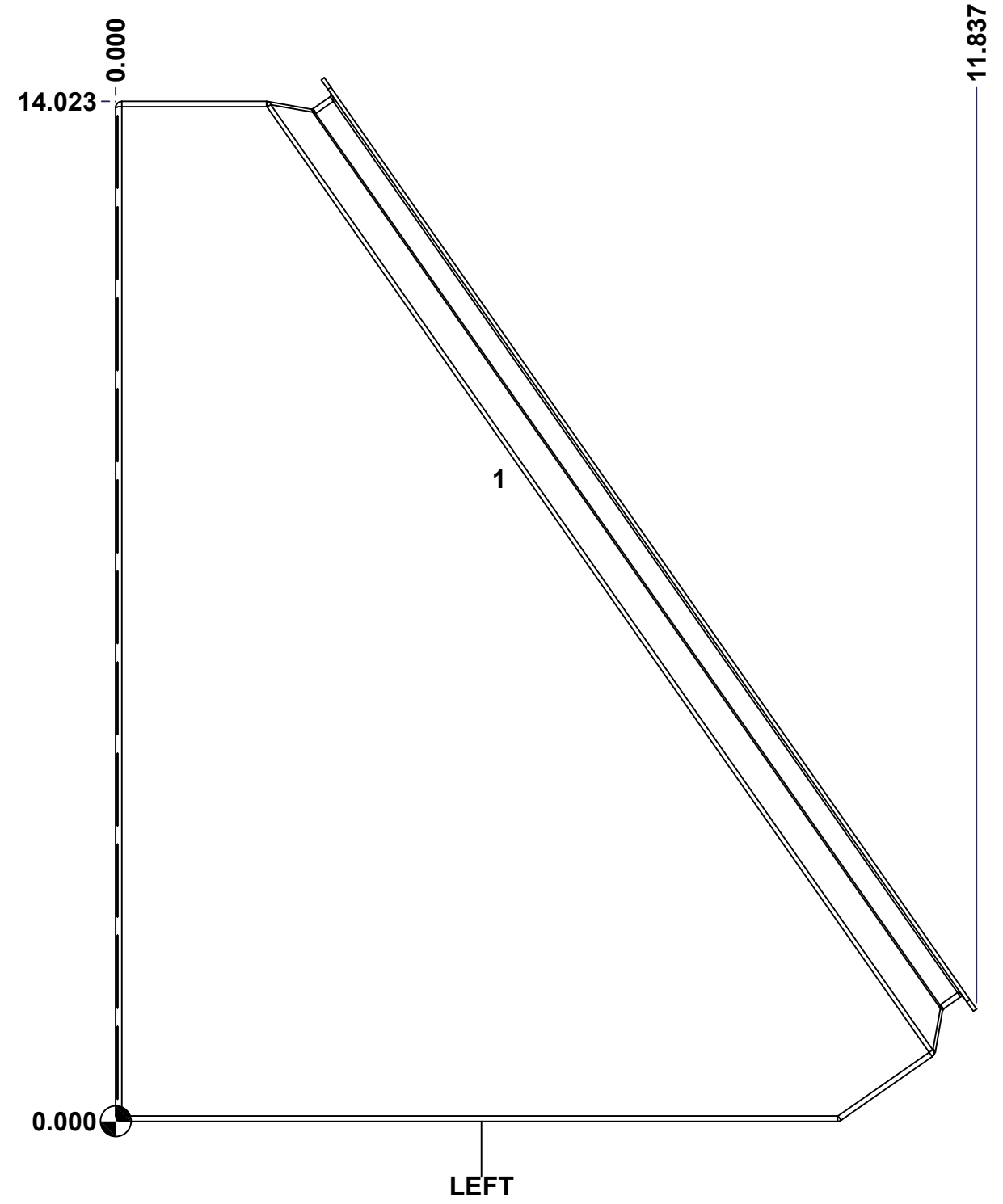

	Description	Status	
	1412CSE 16" x 36" x 11.725" Body	(NULL)	
	Part Number Numéro Pièce	Rev.	6
	1412CSE163611B	0	11

This drawing is confidential and must not be reproduced or used without the consent of EXM

Ce dessin est confidentiel et ne doit pas être reproduit ou utilisé sans le consentement de EXM

STANDARD FEATURES ARE NOT LISTED IN THIS HOLE TABLE			
HOLE TABLE - ANGLE VIEW (CUSTOM FEATURE ONLY)			
CUT-OUT	XDIM	YDIM	DESCRIPTION
1	35.125	0.742	STANDOFF M6 x 10mm (Inside)

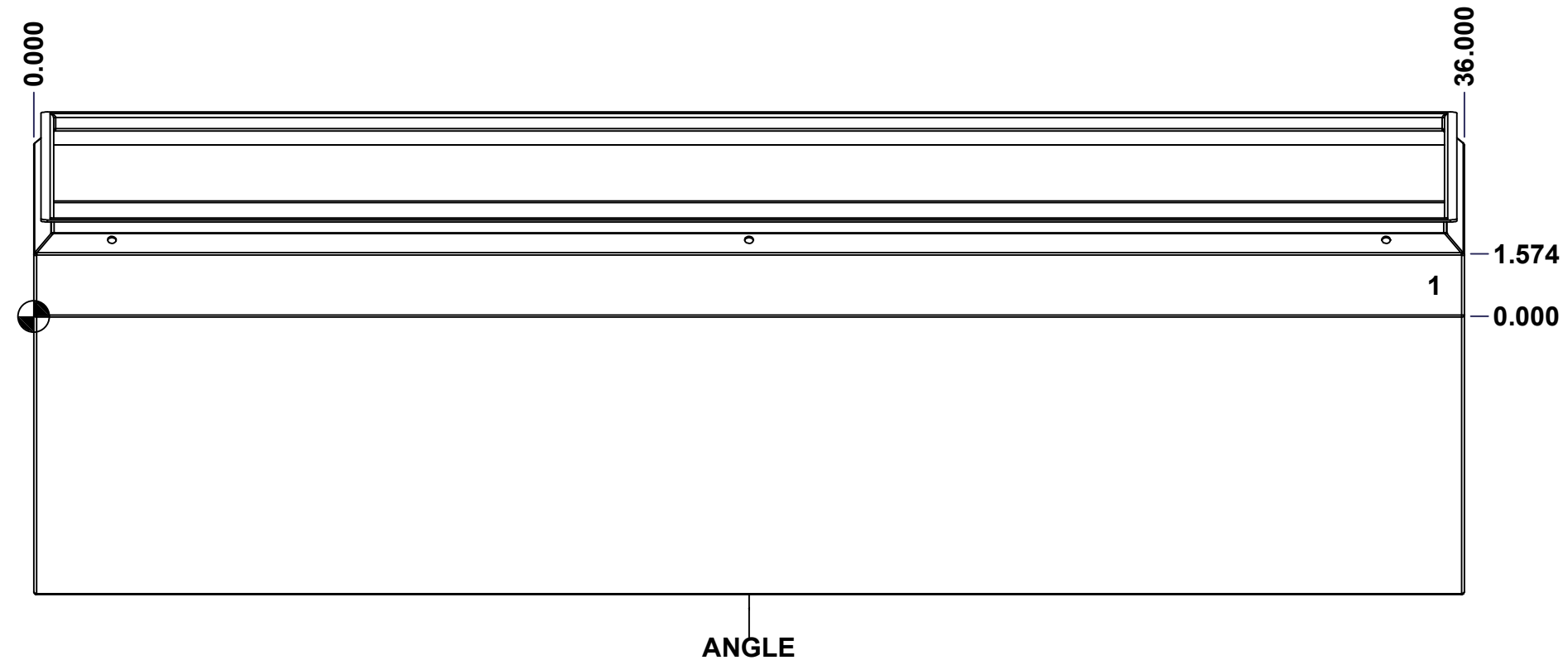

	Description	Status	
	1412CSE 16" x 36" x 11.725" Body	(NULL)	
	Part Number Numéro Pièce	Rev.	7
	1412CSE163611B	0	11

This drawing is confidential and must not be reproduced or used without the consent of EXM

Ce dessin est confidentiel et ne doit pas être reproduit ou utilisé sans le consentement de EXM

No.	Revisions	Date	By/Par

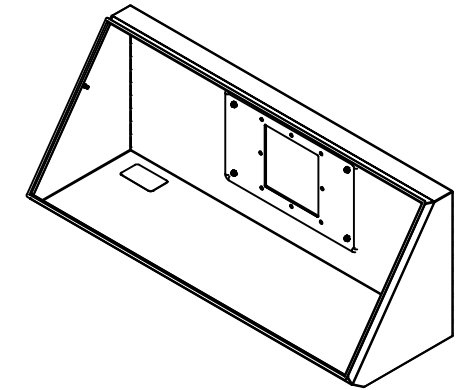

Isometric View



Tél: (450) 979-4373
 Fax: (450) 979-4626
www.exmweb.com

Flatness
Aplatissement
Max 3.0mm
Projection

Customer Client	Date
Drawn By / Dessiné Par: BoxCad: BoxCad	Date: 05-Dec-13
Material / Matière: 16 Ga Cold Rolled A1008 CS Type B (1.4mm)	

Color / Couleur: Asa-61 Grey	Finish / Fini: Textured
Description: 1412CSE 16" x 36" x 11.725" Body	
Detail Rev.	

Part Number / Numéro Pièce: 1412CSE163611B	Rev. 0	8
---	--------	---

Qty	Part_Number	Rev	Description
2	STK-Q-16030	0	Stud M6 x 10mm Steel
1	STK-Q-08350	5	Standoff M6 x 10mm
1	STK-S-00100	0	3.5" x 2" Silver Milar Flexcon Sticker
1	STK-P-02400R	0	Powder Paint (Tiger Drylac #459/15000 Beige RT GL / Rough Textured)
1	1412CSE163611B-P	0	1412CSE 16" x 36" x 11.725" Body Part
1	1500CS_SUP	0	1500CS - Support Plate Part
Parts List			

This drawing is confidential and must not be reproduced or used without the consent of EXM

Ce dessin est confidentiel et ne doit pas être reproduit ou utilisé sans le consentement de EXM



TOP

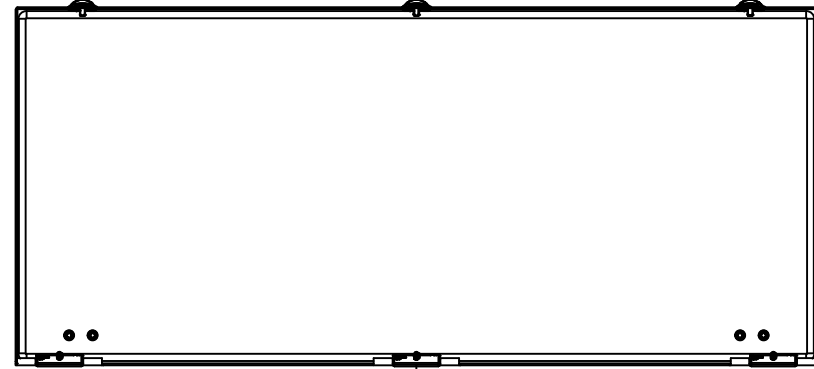

BACK

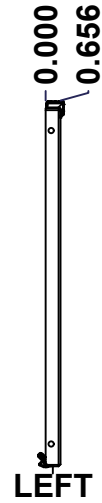

LEFT

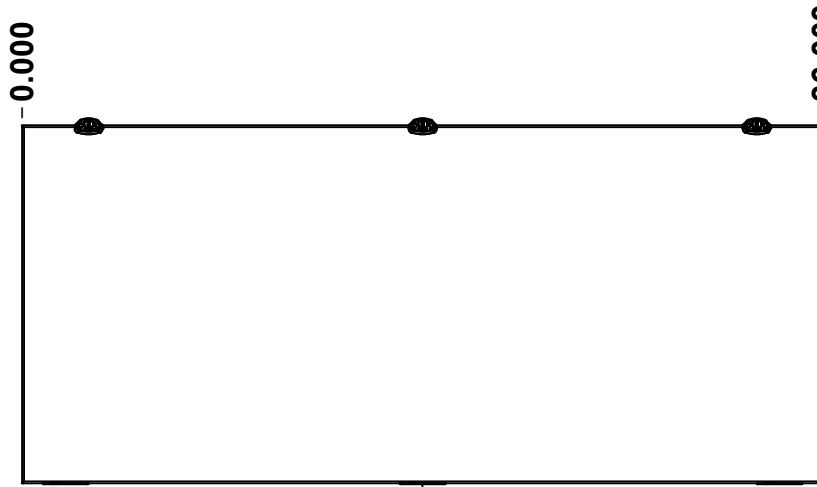

FRONT

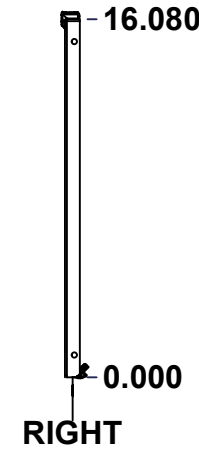

RIGHT

No.	Revisions	Date	By/Par

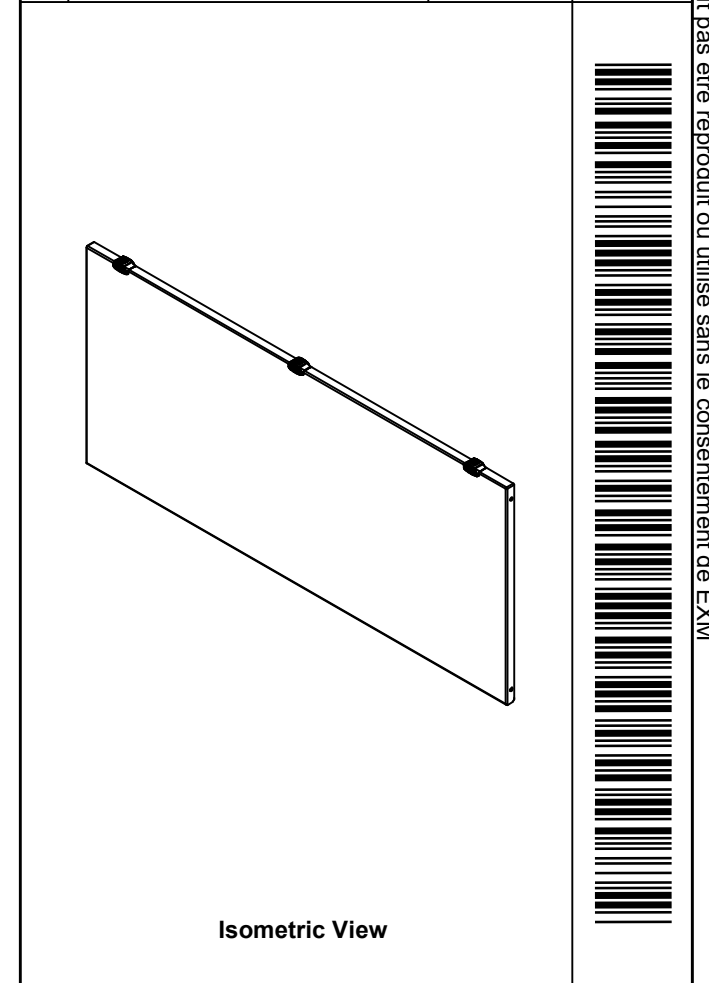

Isometric View

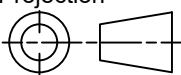

BOTTOM

 Tél: (450) 979-4373 Fax: (450) 979-4626 www.exmweb.com		Flatness Aplatissement Max 3.0mm Projection 
Customer Client	Date	
Drawn By Dessiné Par	BoxCad: BoxCad	Date 05-Dec-13
Material Matière	16 Ga Cold Rolled A1008 CS Type B (1.4mm)	
Color Couleur	Asa-61 Grey	Finish Fini Textured
Description 1412CSE 16" x 36" Cover		Detail Rev.
Part Number Numéro Pièce	Rev. 0	9 / 11

SEE BILL OF MATERIAL ON LAST PAGE

1412CSE163611C

This drawing is confidential and must not be reproduced or used without the consent of EXM

Ce dessin est confidentiel et ne doit pas être reproduit ou utilisé sans le consentement de EXM

STANDARD FEATURES ARE NOT LISTED IN THIS HOLE TABLE

HOLE TABLE - FRONT VIEW (CUSTOM FEATURE ONLY)

CUT-OUT	XDIM	YDIM	DESCRIPTION
1	3.000	16.080	LOCK 880 SCQ2MS @ 90.0°
2	18.000	16.080	LOCK 880 SCQ2MS @ 90.0°
3	33.000	16.080	LOCK 880 SCQ2MS @ 90.0°
4	2.408	1.334	STANDOFF M6 x 10mm (Inside)
5	3.463	1.334	STANDOFF M6 x 10mm (Inside)
6	33.592	1.334	STANDOFF M6 x 10mm (Inside)
7	32.537	1.334	STANDOFF M6 x 10mm (Inside)

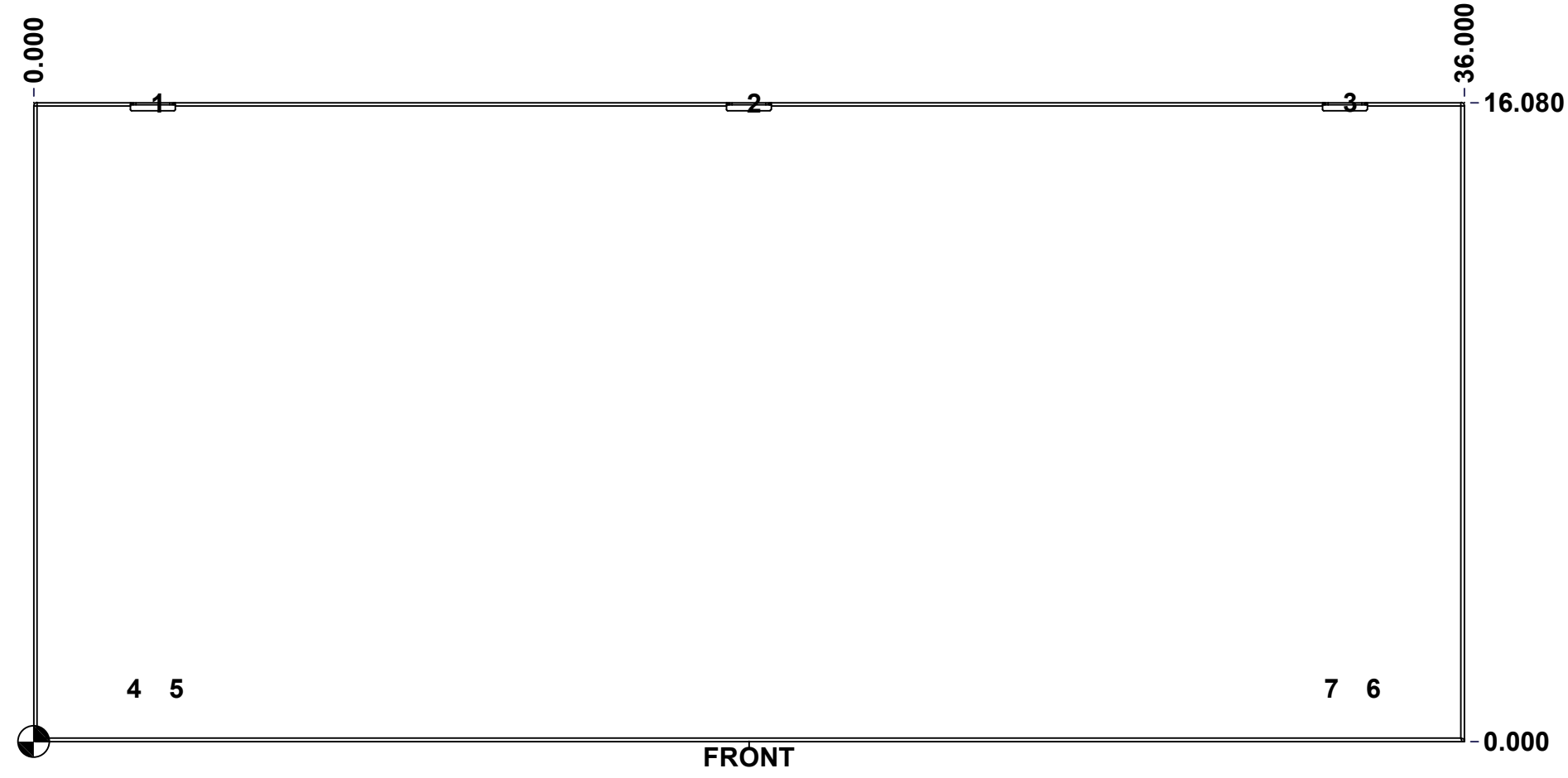



	Description	Status	
	1412CSE 16" x 36" Cover	(NULL)	
	Part Number Numéro Pièce	Rev.	10
	1412CSE163611C	0	11

This drawing is confidential and must not be reproduced or used without the consent of EXM

Ce dessin est confidentiel et ne doit pas être reproduit ou utilisé sans le consentement de EXM

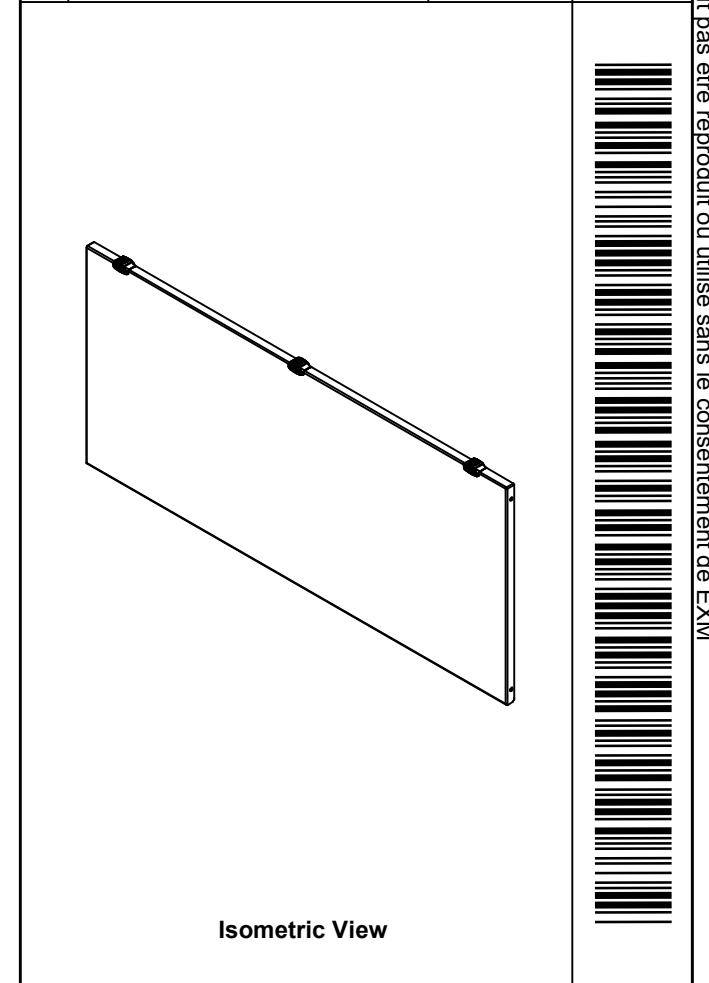
No.	Revisions	Date	By/Par

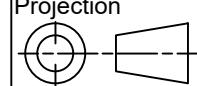

 Tél: (450) 979-4373 Fax: (450) 979-4626 www.exmweb.com		Flatness Aplatissement Max 3.0mm Projection 
Customer Client	Date	
Drawn By Dessiné Par	BoxCad: BoxCad	Date 05-Dec-13
Material Matière	16 Ga Cold Rolled A1008 CS Type B (1.4mm)	
Color Couleur	Asa-61 Grey	Finish Fini Textured
Description		Detail Rev.
1412CSE 16" x 36" Cover		
Part Number Numéro Pièce	Rev.	11
1412CSE163611C	0	11

Qty	Part Name	Rev	Description
4	STK-Q-08350	5	Standoff M6 x 10mm
1	STK-P-02400R	0	Powder Paint (Tiger Drylac #459/15000 Beige RT GL / Rough Textured)
1	1412CSE163611G	0	1412CSE 16" x 36" Gasket
1	1412CSE163611C-P	0	1412CSE 16" x 36" Cover Part
3	STK-A-33024	3	1100 MC Hinge
3	STK-A-79960	14	5412 ESMCH - External Lock Assy - Slot Lock
Parts List			