

This drawing is confidential and must not be reproduced or used without the consent of EXM

Ce dessin est confidentiel et ne doit pas être reproduit ou utilisé sans le consentement de EXM

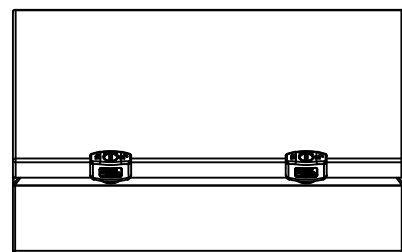

TOP

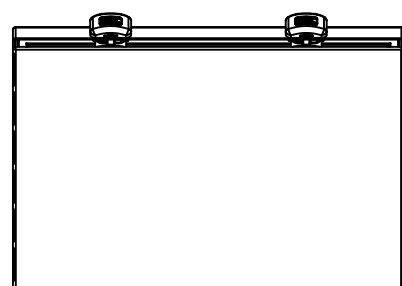

BACK

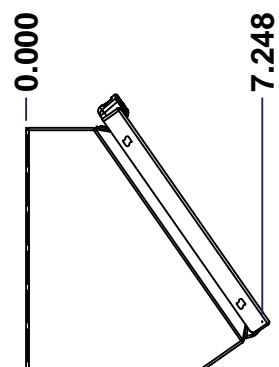

LEFT

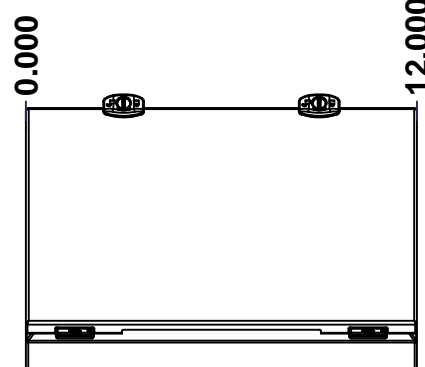

FRONT

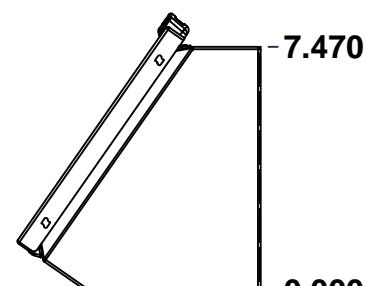

RIGHT

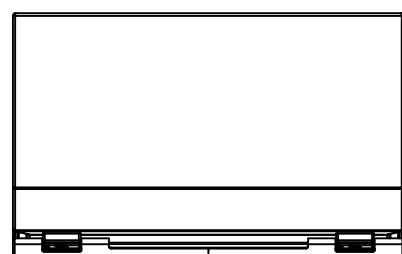

BOTTOM

No.	Revisions	Date	By/Par

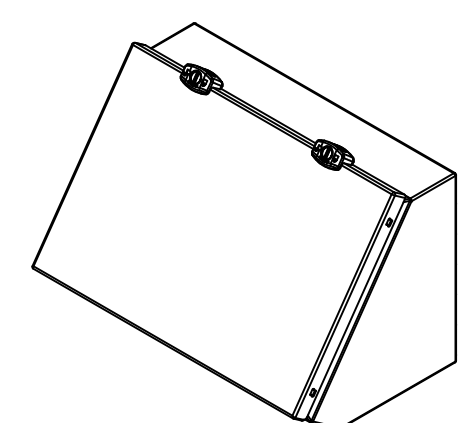

Isometric View

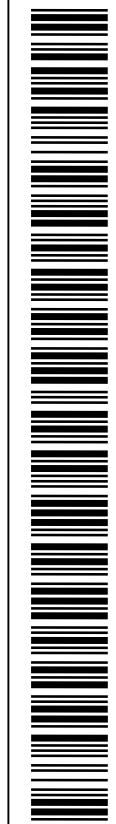

Tél: (450) 979-4373
 Fax: (450) 979-4626
www.exmweb.com

Flatness Aplatissement	Max 3.0mm
Projection	

Customer Client	Date
Drawn By Dessiné Par	Date 05-Dec-13
Material Matière	16 Ga Stainless Steel 304 (1.4mm)
Color Couleur	Unpainted
Finish Fini	Brushed
Description	1412CSS 8" x 12" x 7.137" Assembly
Detail Rev.	
Part Number Numéro Pièce	Rev. 0
	1 2

SEE BILL OF MATERIAL ON LAST PAGE

1412CSS081207

This drawing is confidential and must not be reproduced or used without the consent of EXM

Ce dessin est confidentiel et ne doit pas être reproduit ou utilisé sans le consentement de EXM

NOTE	
ITEM	DESCRIPTION
1	NEMA 4X Enclosure
2	C/W Standard ground standoffs on box and cover
3	W/O Standard door stiffener
4	W/O Inner panel
5	W/O Inner panel mounting standoffs

No.	Revisions	Date	By/Par

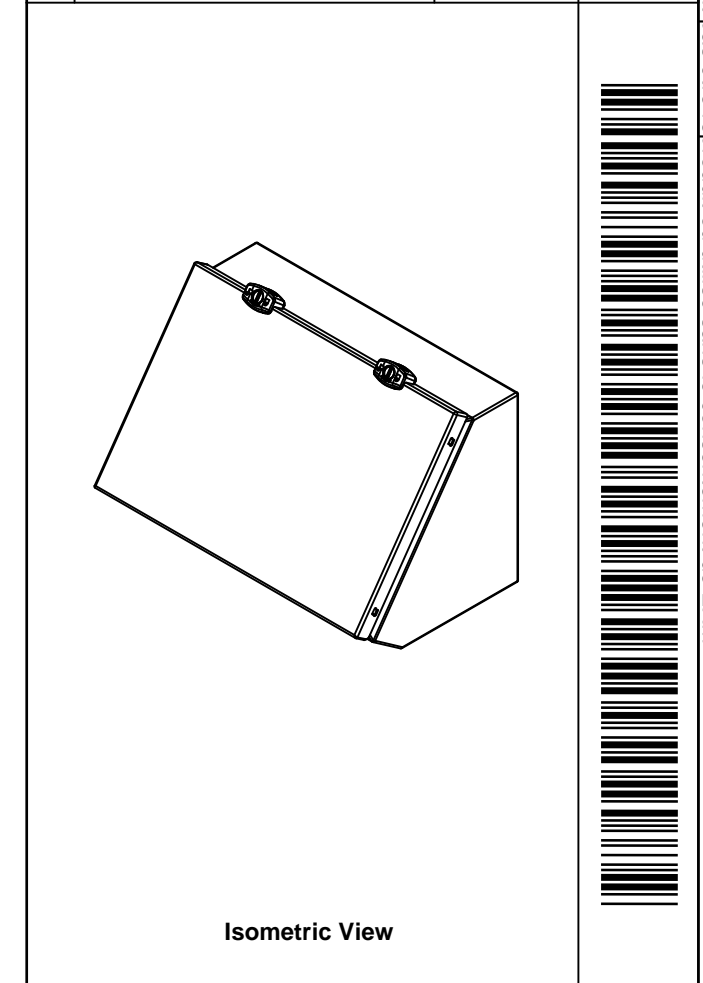

		Tél: (450) 979-4373 Fax: (450) 979-4626 www.exmweb.com		Flatness Aplatissement Max 3.0mm	
Customer Client		Date		Projection 	
Drawn By Dessiné Par		BoxCad: BoxCad		Date 05-Dec-13	
Material Matière		16 Ga Stainless Steel 304 (1.4mm)			
Color Couleur		Unpainted		Finish Fini Brushed	
Description 1412CSS 8" x 12" x 7.137" Assembly				Detail Rev.	
Part Number Numéro Pièce 1412CSS081207				Rev. 2 0	

PACKING		
ITEM	QTY	DESCRIPTION
Cardboard sleeve	2	Top and Bottom
Cardboard strip	2	Between back of enclosure and inner panel
Plastic bag	1	To protect cover surface and inside gasket
Plastic strap - Black	2	To Squeeze the 2 cardboard sleeve together
Packaging label	1	White label with product number

Qty	Part Number	Rev	Description
1	1412CSS081207C	0	1412CSS 8" x 12" Cover
1	1412CSS081207B	0	1412CSS 8" x 12" x 7.137" Body
2	STK-Q-08100	1	M5 Nylon Insert Lock Nut
Parts List			

This drawing is confidential and must not be reproduced or used without the consent of EXM

Ce dessin est confidentiel et ne doit pas être reproduit ou utilisé sans le consentement de EXM

No.	Revisions	Date	By/Par

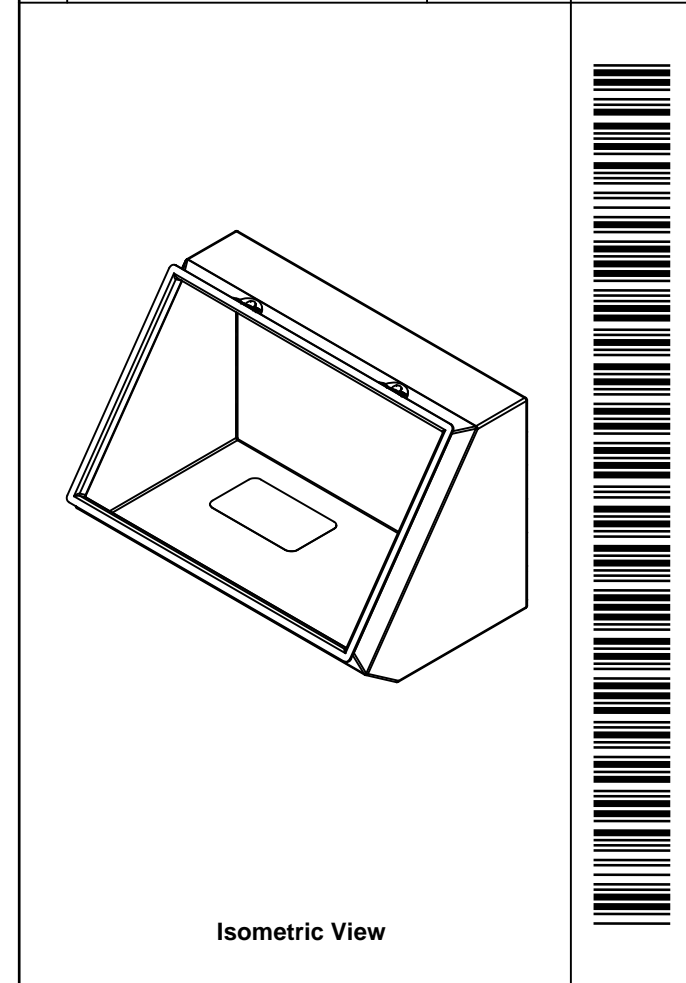

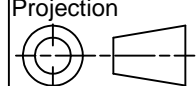
 Tél: (450) 979-4373 Fax: (450) 979-4626 www.exmweb.com		Flatness Aplatissement Max 3.0mm Projection 
Customer Client	Date	
Drawn By Dessiné Par	BoxCad: BoxCad	Date 05-Dec-13
Material Matière	16 Ga Stainless Steel 304 (1.4mm)	
Color Couleur	Unpainted	Finish Fini Brushed
Description	Detail Rev.	
1412CSS 8" x 12" x 7.137" Body		
Part Number Numéro Pièce	Rev.	1 / 7
1412CSS081207B	0	

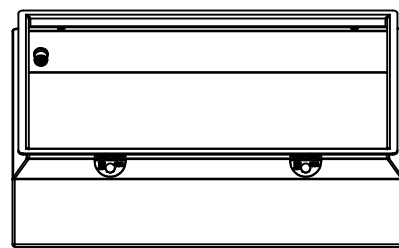

TOP

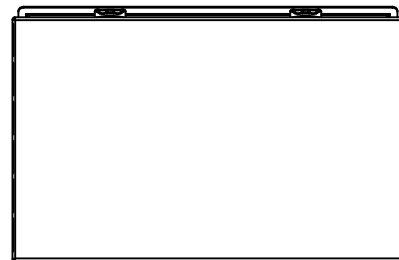

BACK

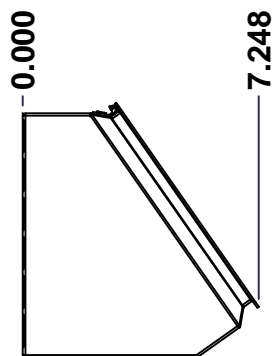

LEFT

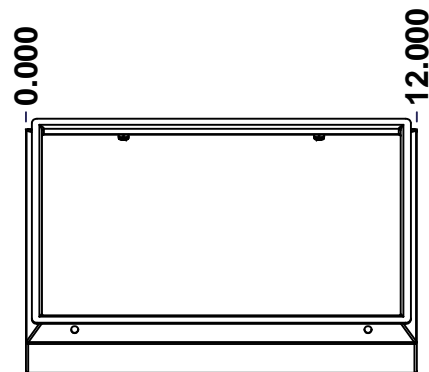

FRONT

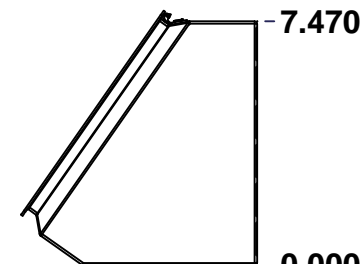

RIGHT



BOTTOM

SEE BILL OF MATERIAL ON LAST PAGE

This drawing is confidential and must not be reproduced or used without the consent of EXM

Ce dessin est confidentiel et ne doit pas être reproduit ou utilisé sans le consentement de EXM

STANDARD FEATURES ARE NOT LISTED IN THIS HOLE TABLE			
HOLE TABLE - ANGLE VIEW (CUSTOM FEATURE ONLY)			
CUT-OUT	XDIM	YDIM	DESCRIPTION
1	11.125	0.742	STANDOFF M6 x 10mm (Inside)

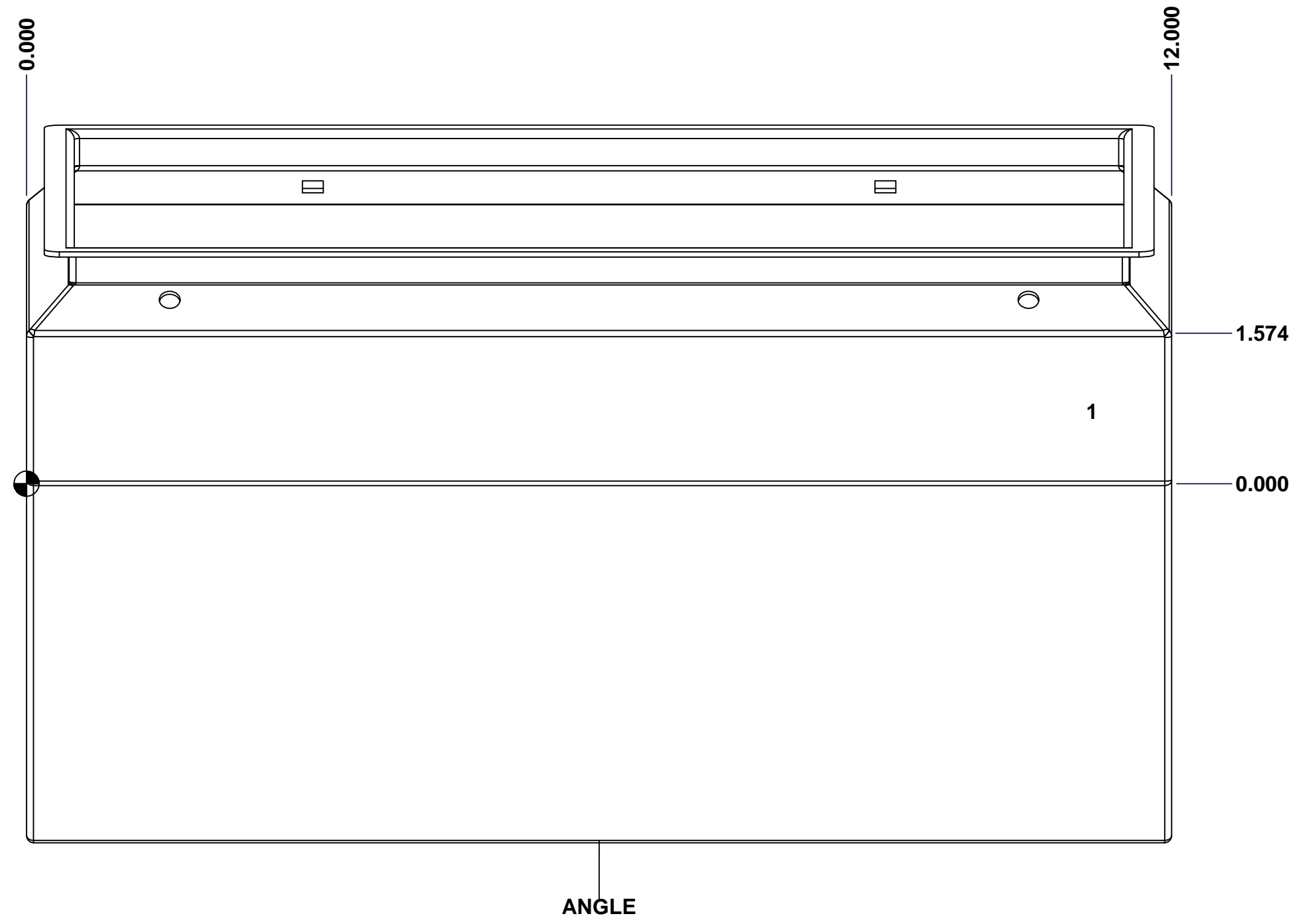



	Description	Status
	1412CSS 8" x 12" x 7.137" Body	(NULL)
	Part Number Numéro Pièce	Rev.
	1412CSS081207B	0
		4 / 7

This drawing is confidential and must not be reproduced or used without the consent of EXM

Ce dessin est confidentiel et ne doit pas être reproduit ou utilisé sans le consentement de EXM

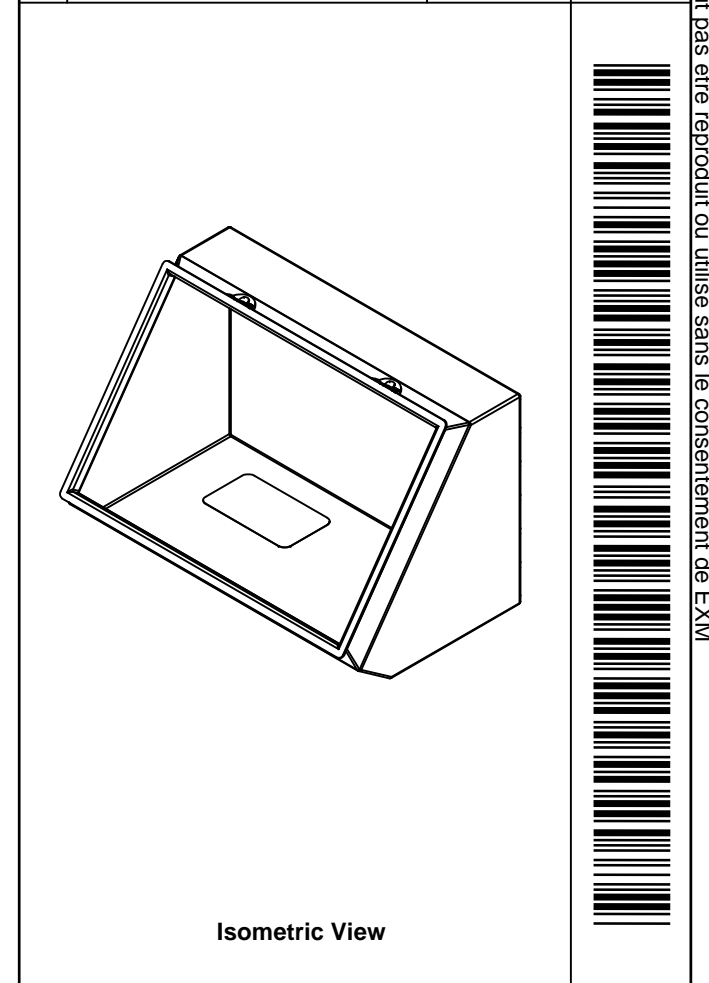
No.	Revisions	Date	By/Par

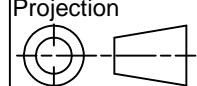

 Tél: (450) 979-4373 Fax: (450) 979-4626 www.exmweb.com		Flatness Aplatissement Max 3.0mm Projection 
Customer Client		Date
Drawn By / Dessiné Par: BoxCad: BoxCad		Date: 05-Dec-13
Material / Matière: 16 Ga Stainless Steel 304 (1.4mm)		
Color / Couleur: Unpainted	Finish / Fini: Brushed	
Description: 1412CSS 8" x 12" x 7.137" Body		Detail Rev.
Part Number / Numéro Pièce: 1412CSS081207B		Rev. 7

Qty	Part_Number	Rev	Description
1	STK-Q-08500	4	Stainless Steel Standoff M6 x 10mm
1	1412CSS081207B-P	0	1412CSS 8" x 12" x 7.137" Body Part
1	STK-S-00100	0	3.5" x 2" Silver Milar Flexcon Sticker
2	STK-A-70469	6	5412 ESSMCH - Stainless Steel 316 Body Catch Assembly
2	STK-Q-08100	1	M5 Nylon Insert Lock Nut
Parts List			

This drawing is confidential and must not be reproduced or used without the consent of EXM

Ce dessin est confidentiel et ne doit pas être reproduit ou utilisé sans le consentement de EXM

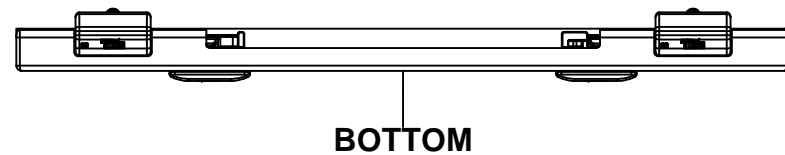
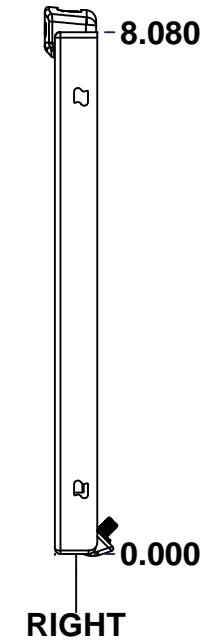
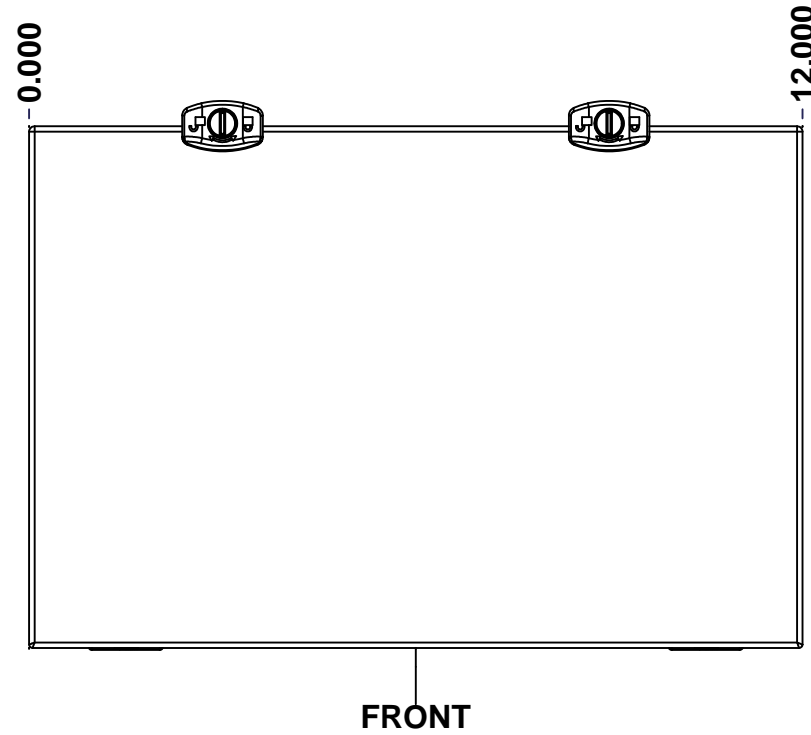
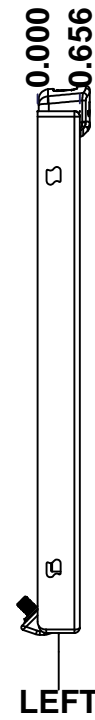
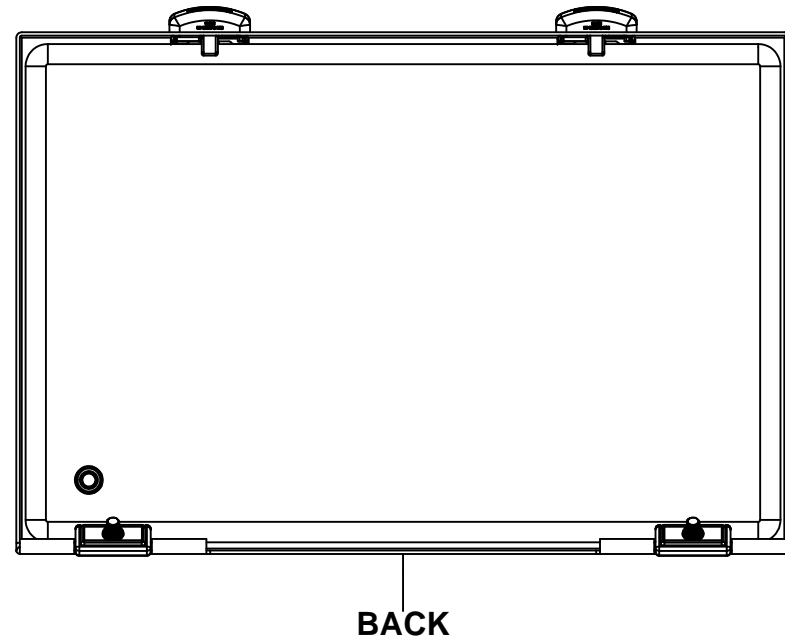
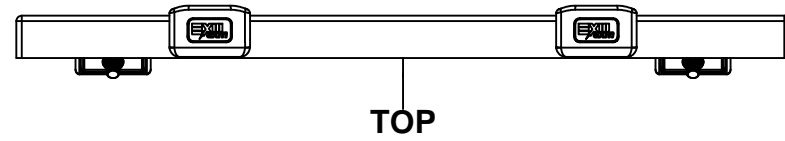

No.	Revisions	Date	By/Par

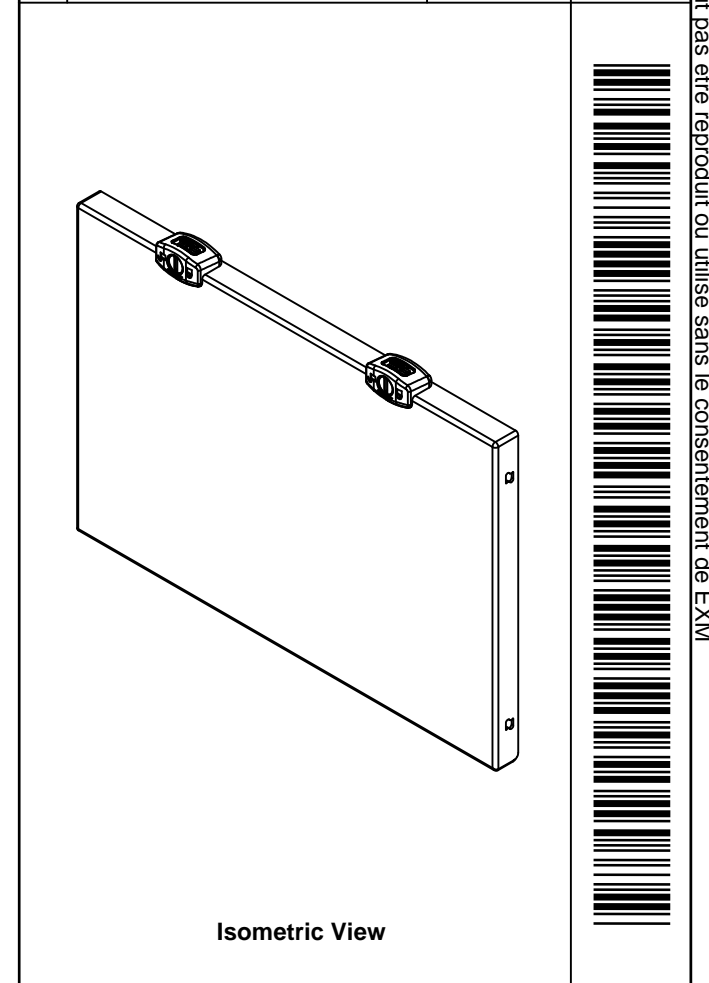

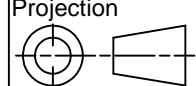
 Tél: (450) 979-4373 Fax: (450) 979-4626 www.exmweb.com		Flatness Aplatissement Max 3.0mm	
		Projection 	
Customer Client		Date	
Drawn By / Dessiné Par: BoxCad: BoxCad		Date: 05-Dec-13	
Material / Matière: 16 Ga Stainless Steel 304 (1.4mm)			
Color / Couleur: Unpainted		Finish / Fini: Brushed	
Description: 1412CSS 8" x 12" Cover		Detail Rev.	
Part Number / Numéro Pièce: 1412CSS081207C		Rev. 0	1 / 3

SEE BILL OF MATERIAL ON LAST PAGE

This drawing is confidential and must not be reproduced or used without the consent of EXM

Ce dessin est confidentiel et ne doit pas être reproduit ou utilisé sans le consentement de EXM

STANDARD FEATURES ARE NOT LISTED IN THIS HOLE TABLE			
HOLE TABLE - FRONT VIEW (CUSTOM FEATURE ONLY)			
CUT-OUT	XDIM	YDIM	DESCRIPTION
1	10.875	1.145	STANDOFF M6 x 10mm (Inside)
2	3.000	8.080	LOCK 880 SCQ3MS @ 90.0°
3	9.000	8.080	LOCK 880 SCQ3MS @ 90.0°

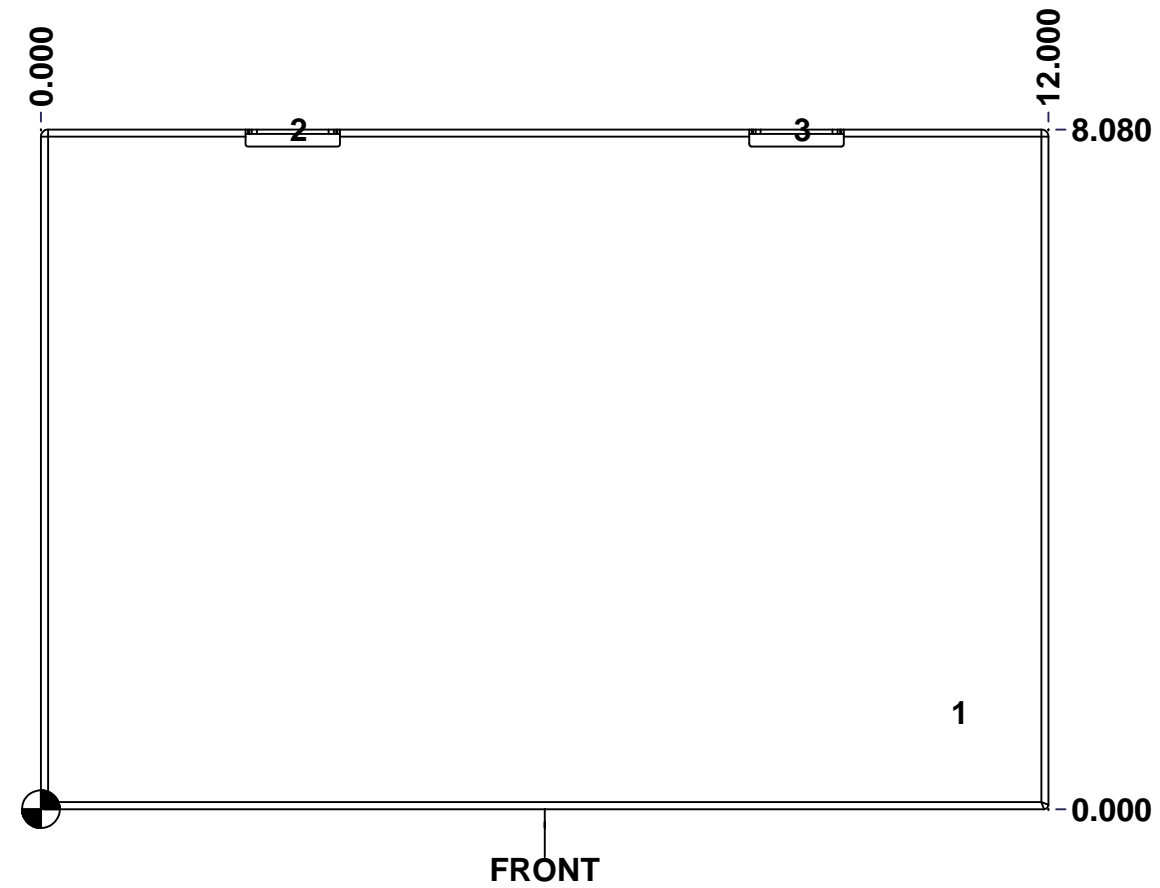



	Description	Status
	1412CSS 8" x 12" Cover	(NULL)
	Part Number Numéro Pièce	Rev.
	1412CSS081207C	0
		2
		3

This drawing is confidential and must not be reproduced or used without the consent of EXM

Ce dessin est confidentiel et ne doit pas être reproduit ou utilisé sans le consentement de EXM

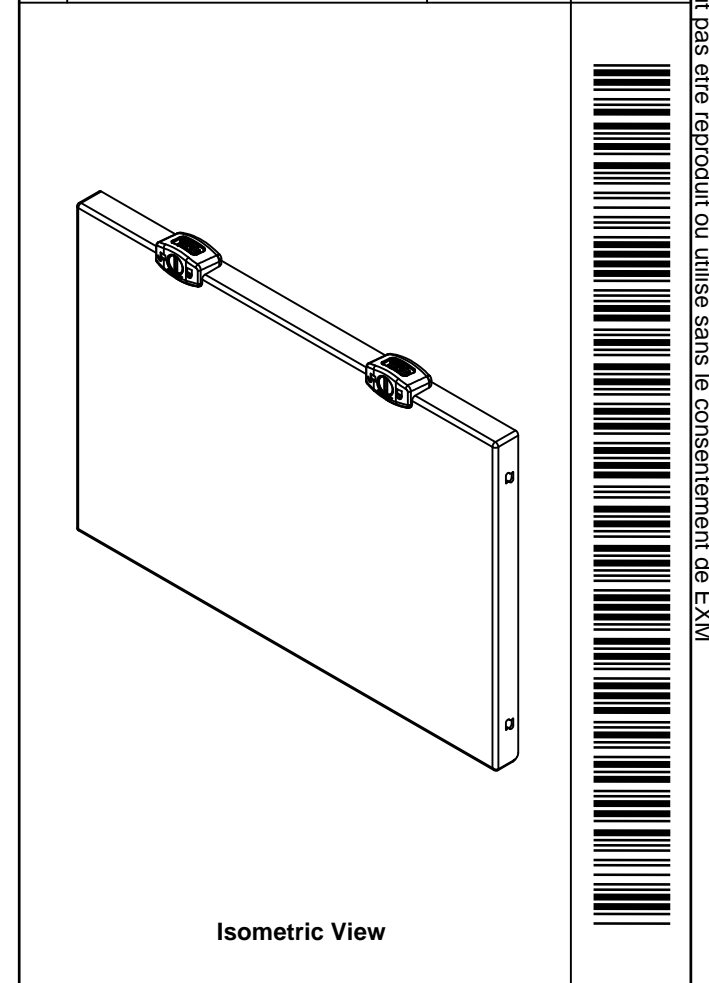
No.	Revisions	Date	By/Par

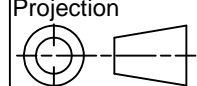

 Tél: (450) 979-4373 Fax: (450) 979-4626 www.exmweb.com		Flatness Aplatissement Max 3.0mm Projection 
Customer Client	Date	
Drawn By Dessiné Par	BoxCad: BoxCad	Date 05-Dec-13
Material Matière	16 Ga Stainless Steel 304 (1.4mm)	
Color Couleur	Unpainted	Finish Fini Brushed
Description		Detail Rev.
1412CSS 8" x 12" Cover		
Part Number Numéro Pièce	Rev.	3
1412CSS081207C	0	3

Qty	Part Name	Rev	Description
1	STK-Q-08500	4	Stainless Steel Standoff M6 x 10mm
1	1412CSS081207G	0	1412CSS 8" x 12" Gasket
1	1412CSS081207C-P	0	1412CSS 8" x 12" Cover Part
2	880SCQ3S	4	5412 ESSMCH - Stainless Steel External Lock Assy - Slot Lock
2	STK-A-33038	3	5412 ESSMCH - Stainless Steel Hinge
Parts List			