

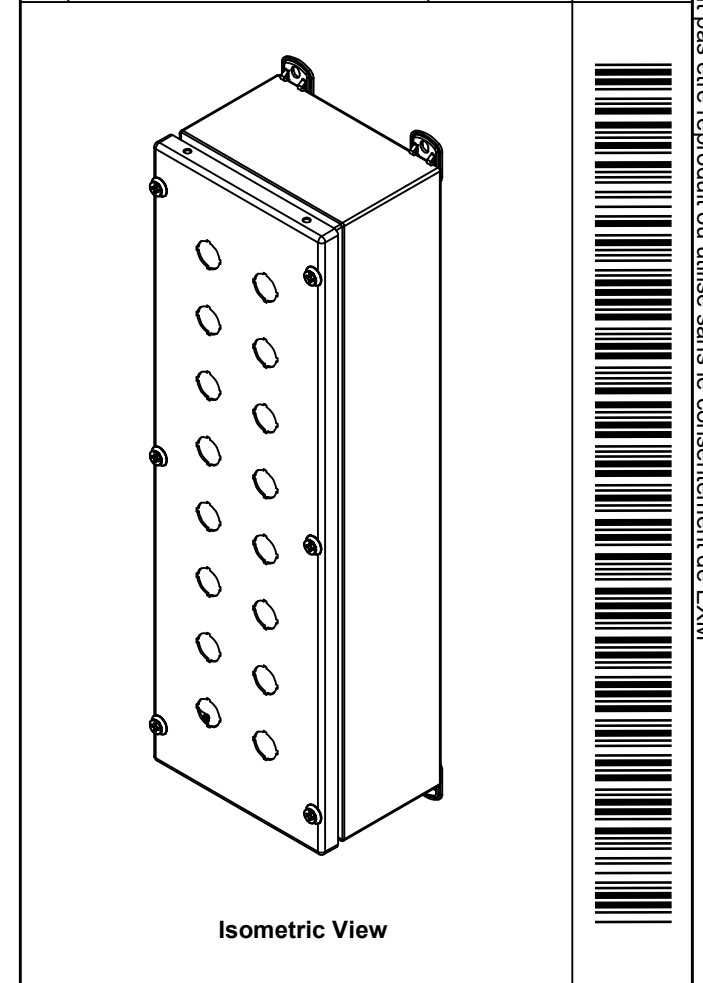

This drawing is confidential and must not be reproduced or used without the consent of EXM

Ce dessin est confidentiel et ne doit pas être reproduit ou utilisé sans le consentement de EXM

No.	Revisions	Date	By/Par

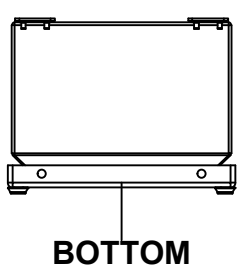
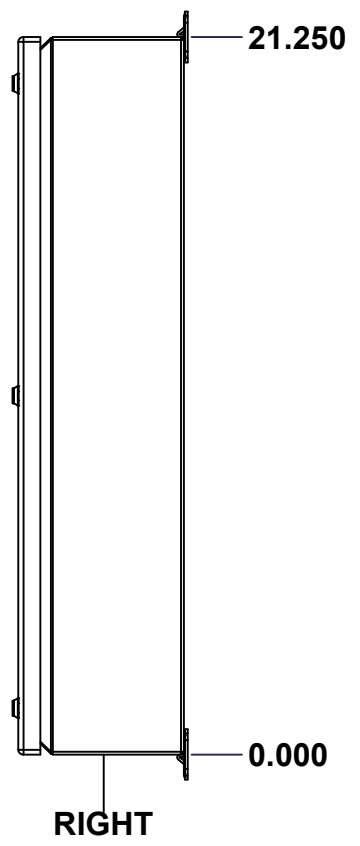
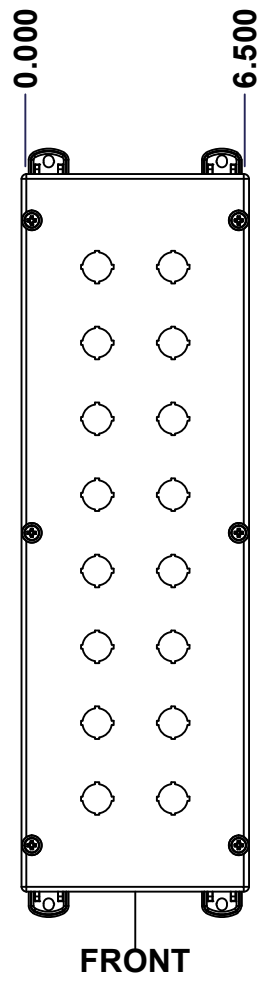
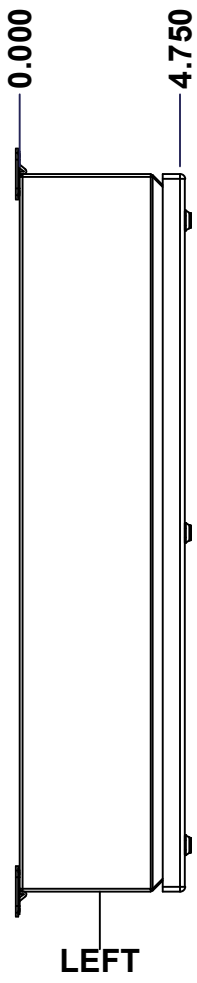
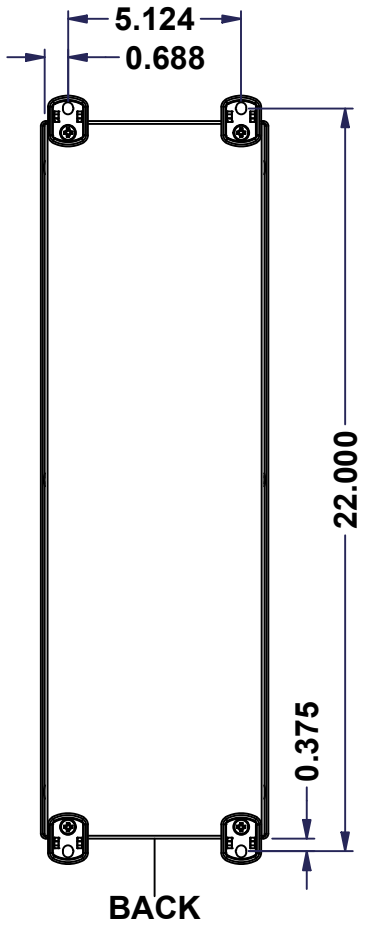
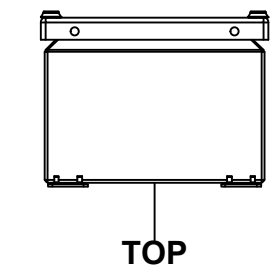

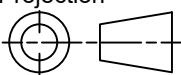
 Tél: (450) 979-4373 Fax: (450) 979-4626 www.exmweb.com		Flatness Aplatissement
		Max 3.0mm
Projection 		Date
Customer Client	BoxCad: BoxCad	Date
Drawn By Dessiné Par	16 Ga Cold Rolled A1008 CS Type B (1.4mm)	01-Oct-25
Material Matière	Color Couleur	Finish Fini
	Asa-61 Grey	Smooth
Description		Detail Rev.
1412ED 21.25" x 6.5" x 4.75" Assembly		
Part Number Numéro Pièce	Rev.	1
1412ED200604MN	0	9

SEE BILL OF MATERIAL ON LAST PAGE

This drawing is confidential and must not be reproduced or used without the consent of EXM

Ce dessin est confidentiel et ne doit pas être reproduit ou utilisé sans le consentement de EXM

NOTE	
ITEM	DESCRIPTION
1	NEMA 4, 12 Enclosure (IP66)
2	C/W Standard ground standoffs on box and cover
3	W/O Standard door stiffener
4	W/O Inner panel
5	W/O Inner panel mounting standoffs
6	C/W 885 ESCHMF1 Mounting Feet (Installed)

No.	Revisions	Date	By/Par

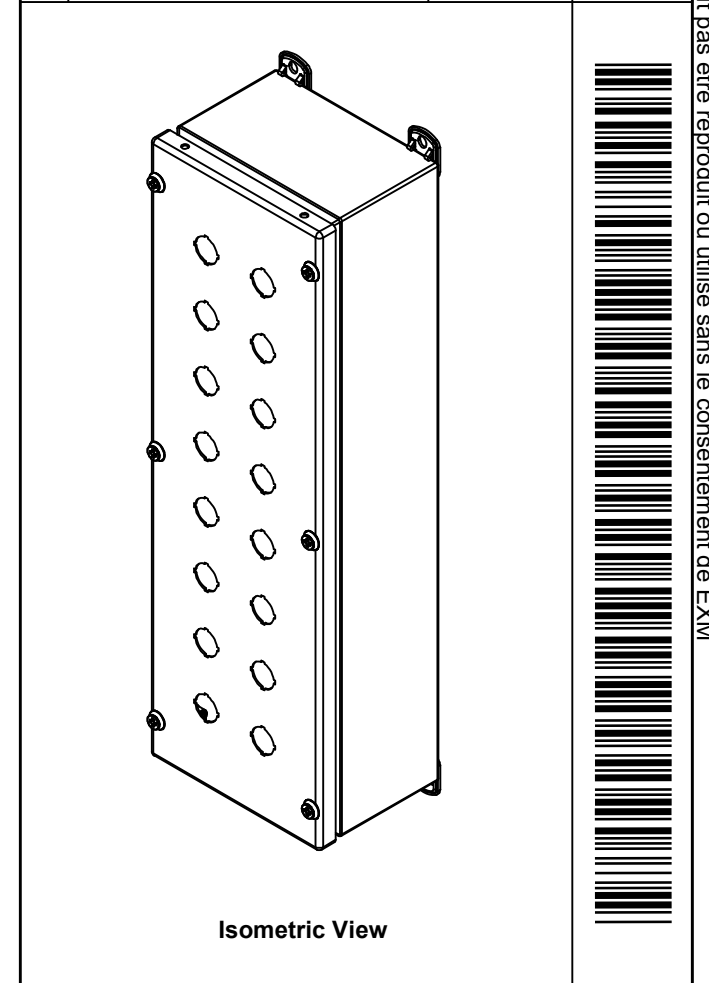

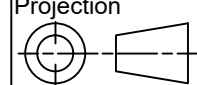
 Tél: (450) 979-4373 Fax: (450) 979-4626 www.exmweb.com	Flatness Aplatissement
	Max 3.0mm
Projection	
Customer Client	Date
Drawn By Dessiné Par BoxCad: BoxCad	Date 01-Oct-25
Material Matière 16 Ga Cold Rolled A1008 CS Type B (1.4mm)	
Color Couleur Asa-61 Grey	Finish Fini Smooth

PACKING		
ITEM	QTY	DESCRIPTION
Cardboard sleeve	2	Top and Bottom
Cardboard strip	2	Between back of enclosure and inner panel
Plastic bag	1	To protect cover surface and inside gasket
Plastic strap - Black	2	To Squeeze the 2 cardboard sleeve together
Packaging label	1	White label with product number

Qty	Part Number	Rev	Description
1	STK-K-02920	3	5412 ESSC Accessory Kit
1	1412ED200604MNC	0	1412ED 21.25" x 6.5" Cover
1	1412ED200604MNB	0	1412ED 21.25" x 6.5" x 4.75" Body
Parts List			

Description	Detail Rev.
1412ED 21.25" x 6.5" x 4.75" Assembly	
Part Number Numéro Pièce	Rev.
1412ED200604MN	0
	2
	9

This drawing is confidential and must not be reproduced or used without the consent of EXM

Ce dessin est confidentiel et ne doit pas être reproduit ou utilisé sans le consentement de EXM

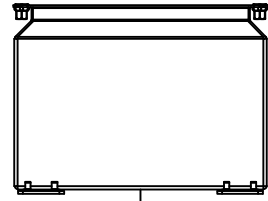

TOP

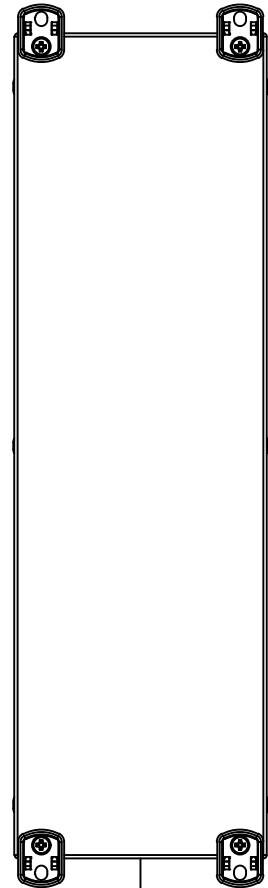

BACK

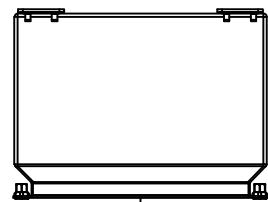

BOTTOM

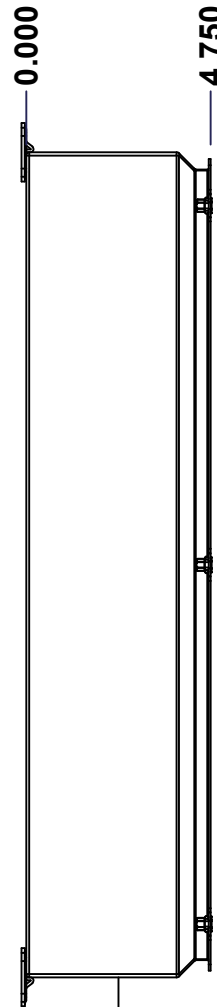

LEFT

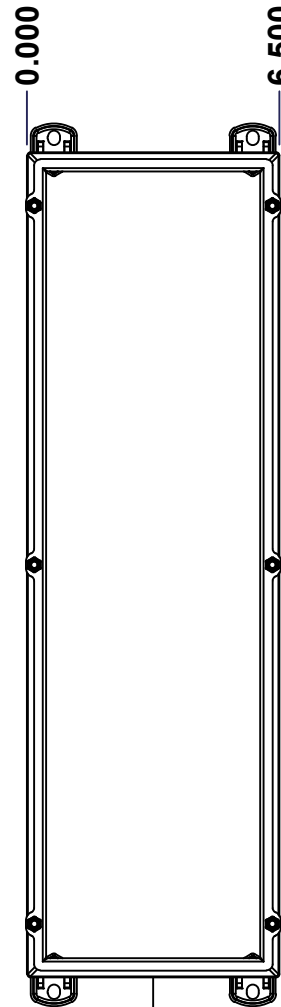

FRONT

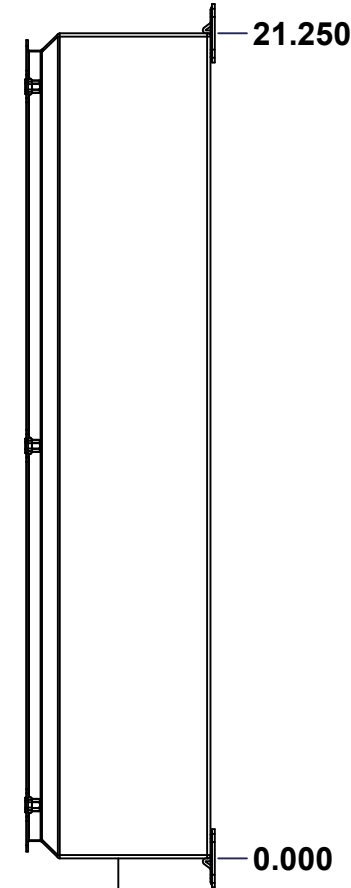

RIGHT

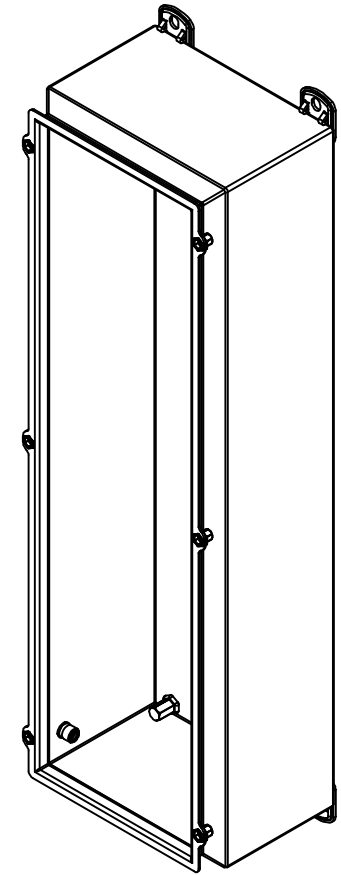

Isometric View

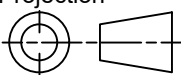

No.	Revisions	Date	By/Par

 Tél: (450) 979-4373 Fax: (450) 979-4626 www.exmweb.com		Flatness Aplatissement Max 3.0mm Projection 
Customer Client	Date	
Drawn By Dessiné Par	BoxCad: BoxCad	Date 01-Oct-25
Material Matière	16 Ga Cold Rolled A1008 CS Type B (1.4mm)	
Color Couleur	Asa-61 Grey	Finish Fini Smooth
Description	Detail Rev.	
1412ED 21.25" x 6.5" x 4.75" Body		
Part Number Numéro Pièce	Rev.	3
1412ED200604MNB	0	9

SEE BILL OF MATERIAL ON LAST PAGE

This drawing is confidential and must not be reproduced or used without the consent of EXM

Ce dessin est confidentiel et ne doit pas être reproduit ou utilisé sans le consentement de EXM

STANDARD FEATURES ARE NOT LISTED IN THIS HOLE TABLE			
HOLE TABLE - LEFT VIEW (CUSTOM FEATURE ONLY)			
CUT-OUT	XDIM	YDIM	DESCRIPTION
1	3.375	0.875	STANDOFF M6 x 10mm (Inside)

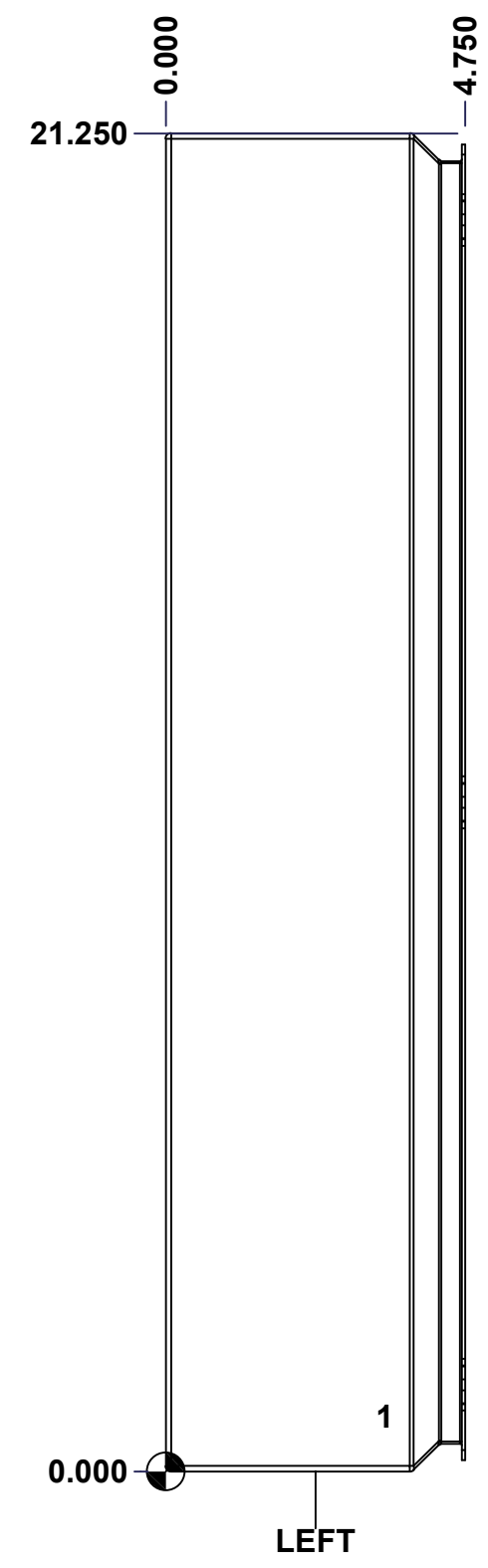

	Description	Status
	1412ED 21.25" x 6.5" x 4.75" Body	(NULL)
	Part Number Numéro Pièce	Rev.
	1412ED200604MNB	0 / 4 9

This drawing is confidential and must not be reproduced or used without the consent of EXM

Ce dessin est confidentiel et ne doit pas être reproduit ou utilisé sans le consentement de EXM

STANDARD FEATURES ARE NOT LISTED IN THIS HOLE TABLE

HOLE TABLE - BACK VIEW (CUSTOM FEATURE ONLY)

CUT-OUT	XDIM	YDIM	DESCRIPTION
1	0.688	0.000	FOOT 885 ESCHMF1
2	0.688	21.250	FOOT 885 ESCHMF1
3	5.812	0.000	FOOT 885 ESCHMF1
4	5.812	21.250	FOOT 885 ESCHMF1
5	0.688	0.344	RIVET NUT M6_FH_CE (Inside)
6	0.688	20.906	RIVET NUT M6_FH_CE (Inside)
7	5.812	0.344	RIVET NUT M6_FH_CE (Inside)
8	5.812	20.906	RIVET NUT M6_FH_CE (Inside)

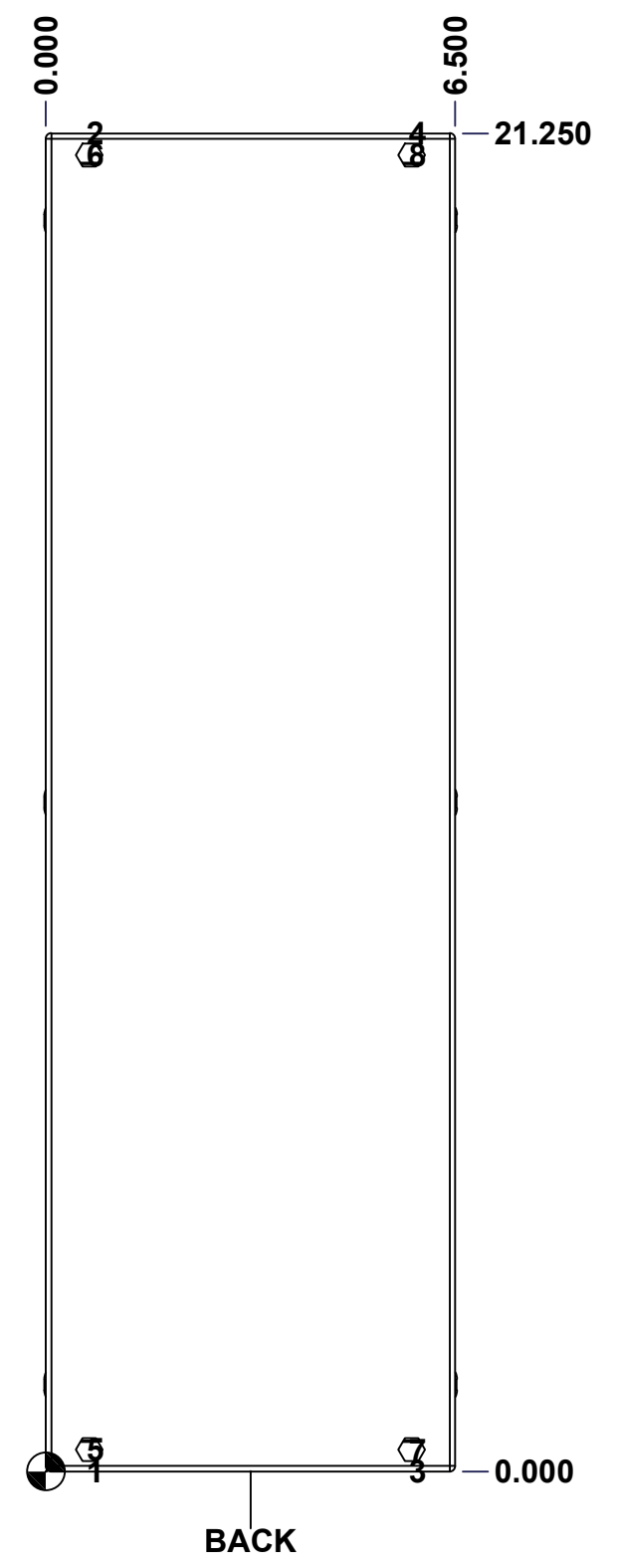

	Description	Status	
	1412ED 21.25" x 6.5" x 4.75" Body	(NULL)	
	Part Number Numéro Pièce	Rev.	
	1412ED200604MNB	0	5 9

This drawing is confidential and must not be reproduced or used without the consent of EXM

Ce dessin est confidentiel et ne doit pas être reproduit ou utilisé sans le consentement de EXM

No.	Revisions	Date	By/Par

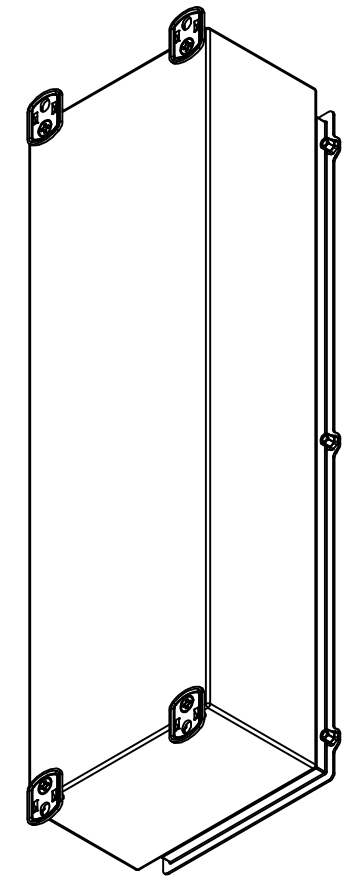

Isometric View

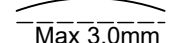

 Tél: (450) 979-4373 Fax: (450) 979-4626 www.exmweb.com		Flatness Aplatissement  Max 3.0mm
Customer Client		Date
Drawn By / Dessiné Par: BoxCad: BoxCad		Date: 01-Oct-25
Material / Matière: 16 Ga Cold Rolled A1008 CS Type B (1.4mm)		
Color / Couleur: Asa-61 Grey	Finish / Fini: Smooth	
Description: 1412ED 21.25" x 6.5" x 4.75" Body		Detail Rev.
Part Number / Numéro Pièce: 1412ED200604MNB		Rev. 6 0 9

Qty	Part Number	Rev	Description
4	RIVET_NUT_M6_FH_CE	0	Rivet Nut M6 (Low Profile Close End)
1	STK-Q-08350	5	Standoff M6 x 10mm
4	STK-Q-03071	0	M6 x 16mm Machine Screw
4	885 ESCHMF1	2	5412 ESCH Stamped Mounting Foot
1	STK-P-02400S	0	Powder Paint (Asa-61 Grey / Smooth)
6	RIVET_NUT_M5_FH_OE	0	Rivet Nut M5 (Low Profile Open End)
1	1412ED200604MNB-P	0	1412EDMN 21.25" x 6.5" x 4.75" Body Part
Parts List			

This drawing is confidential and must not be reproduced or used without the consent of EXM

Ce dessin est confidentiel et ne doit pas être reproduit ou utilisé sans le consentement de EXM

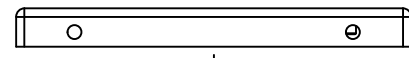

TOP

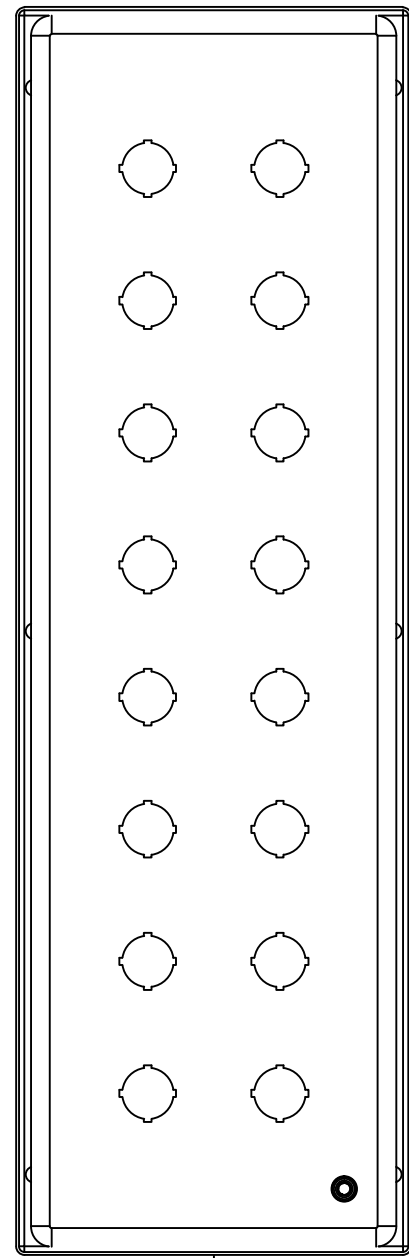

BACK

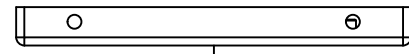

BOTTOM

0.000
0.800

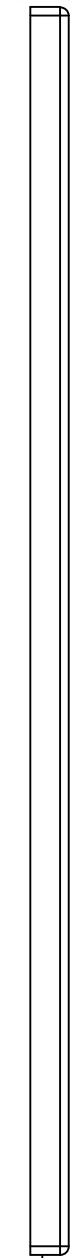

LEFT

0.000
6.736

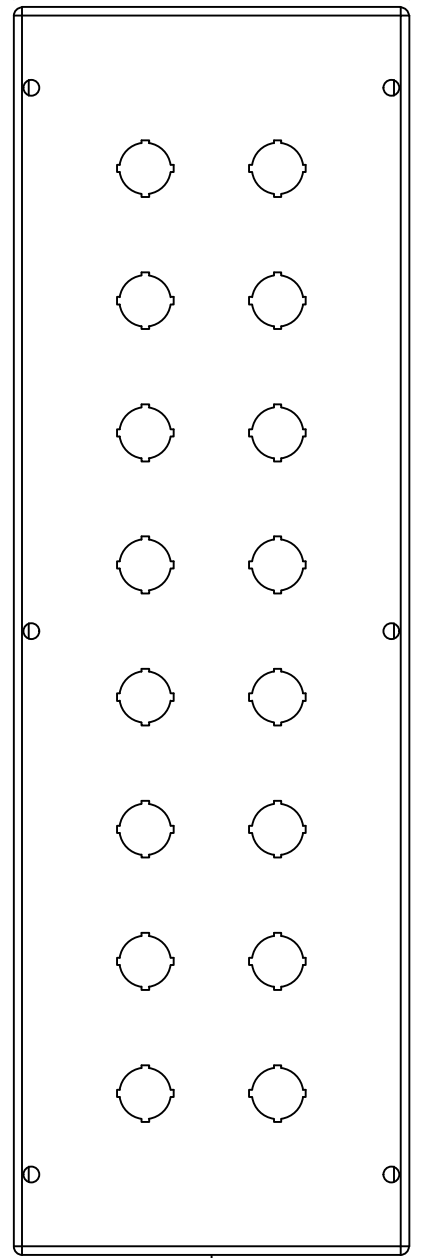

FRONT

21.250

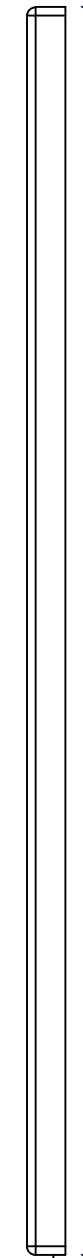

RIGHT

0.000

No.	Revisions	Date	By/Par

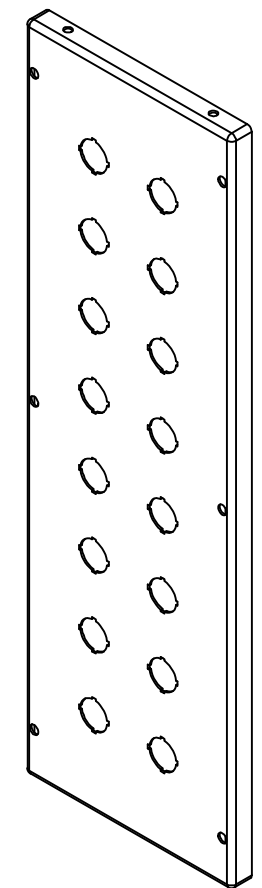

Isometric View



Tél: (450) 979-4373
Fax: (450) 979-4626
www.exmweb.com

Flatness
Aplatissement
Max 3.0mm
Projection

Customer Client	Date
Drawn By / Dessiné Par: BoxCad: BoxCad	Date: 01-Oct-25
Material / Matière: 16 Ga Cold Rolled A1008 CS Type B (1.4mm)	
Color / Couleur: Asa-61 Grey	Finish / Fini: Smooth

Description: 1412ED 21.25" x 6.5" Cover	Detail Rev.
Part Number / Numéro Pièce: 1412ED200604MNC	Rev. 7

SEE BILL OF MATERIAL ON LAST PAGE

1412ED200604MNC

Rev. 0

This drawing is confidential and must not be reproduced or used without the consent of EXM

Ce dessin est confidentiel et ne doit pas être reproduit ou utilisé sans le consentement de EXM

STANDARD FEATURES ARE NOT LISTED IN THIS HOLE TABLE

HOLE TABLE - FRONT VIEW (CUSTOM FEATURE ONLY)

CUT-OUT	XDIM	YDIM	DESCRIPTION
1	2.243	2.750	22.5 mm Miniature Pushbutton
2	2.243	5.000	22.5 mm Miniature Pushbutton
3	2.243	7.250	22.5 mm Miniature Pushbutton
4	2.243	9.500	22.5 mm Miniature Pushbutton
5	2.243	11.750	22.5 mm Miniature Pushbutton
6	2.243	14.000	22.5 mm Miniature Pushbutton
7	2.243	16.250	22.5 mm Miniature Pushbutton
8	2.243	18.500	22.5 mm Miniature Pushbutton
9	4.493	2.750	22.5 mm Miniature Pushbutton
10	4.493	5.000	22.5 mm Miniature Pushbutton
11	4.493	7.250	22.5 mm Miniature Pushbutton
12	4.493	9.500	22.5 mm Miniature Pushbutton
13	4.493	11.750	22.5 mm Miniature Pushbutton
14	4.493	14.000	22.5 mm Miniature Pushbutton
15	4.493	16.250	22.5 mm Miniature Pushbutton
16	4.493	18.500	22.5 mm Miniature Pushbutton
17	1.145	1.125	STANDOFF M6 x 10mm (Inside)

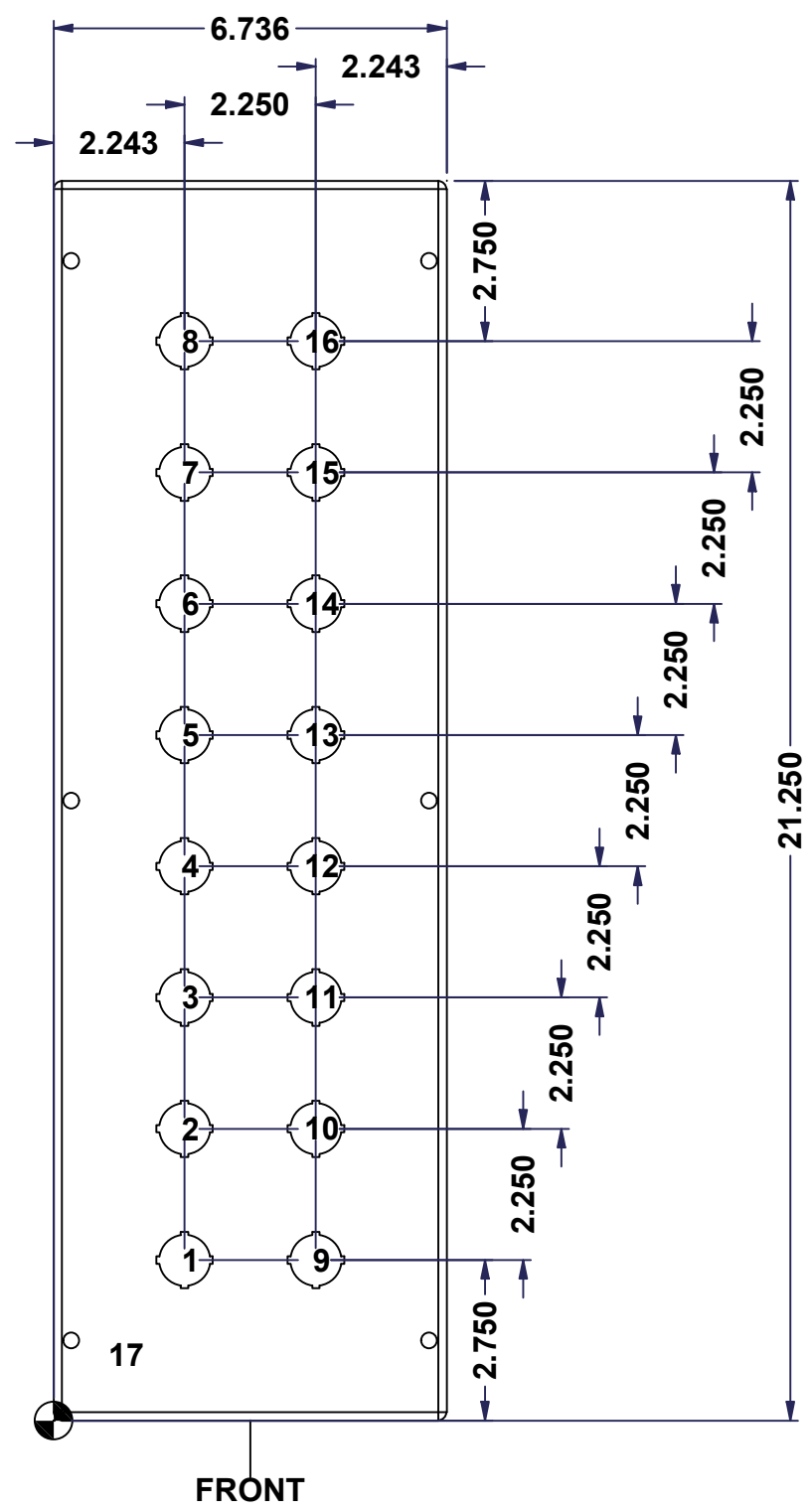

FRONT

	Description	Status
	1412ED 21.25" x 6.5" Cover	(NULL)
	Part Number	Rev.
	1412ED200604MNC	8
		9

This drawing is confidential and must not be reproduced or used without the consent of EXM

Ce dessin est confidentiel et ne doit pas être reproduit ou utilisé sans le consentement de EXM

No.	Revisions	Date	By/Par

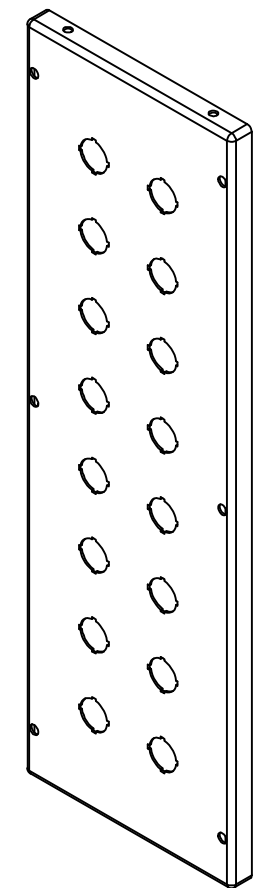

Isometric View



 Tél: (450) 979-4373 Fax: (450) 979-4626 www.exmweb.com	Flatness Aplatissement	Max 3.0mm
	Projection	
Customer Client	Date	
Drawn By Dessiné Par	BoxCad: BoxCad	Date 01-Oct-25
Material Matière	16 Ga Cold Rolled A1008 CS Type B (1.4mm)	
Color Couleur	Asa-61 Grey	Finish Fini Smooth
Description	1412ED 21.25" x 6.5" Cover	
Part Number Numéro Pièce	1412ED200604MNC	Detail Rev. 9
	Rev. 0	9

QTY	Part Number	Rev	Description
1	STK-Q-08350	5	Standoff M6 x 10mm
1	STK-P-02400S	0	Powder Paint (Asa-61 Grey / Smooth)
1	1412ED200604MNG	0	1412ED 21.25" x 6.5" Gasket
1	1412ED200604MNC-P	0	1412EDMN 21.25" x 6.5" Cover Part
Parts List			