

This drawing is confidential and must not be reproduced or used without the consent of EXM

Ce dessin est confidentiel et ne doit pas être reproduit ou utilisé sans le consentement de EXM

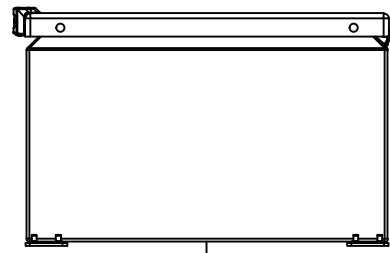

TOP

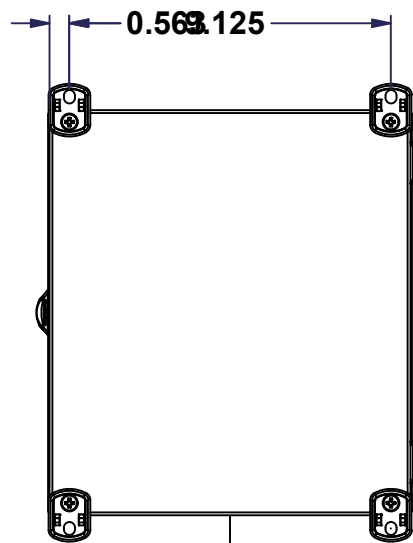

BACK

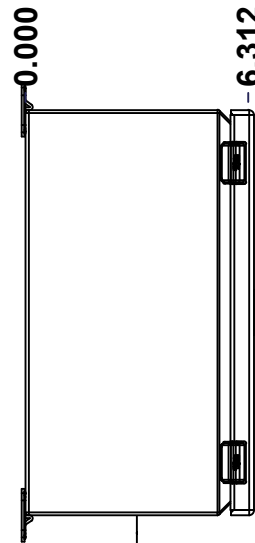

LEFT

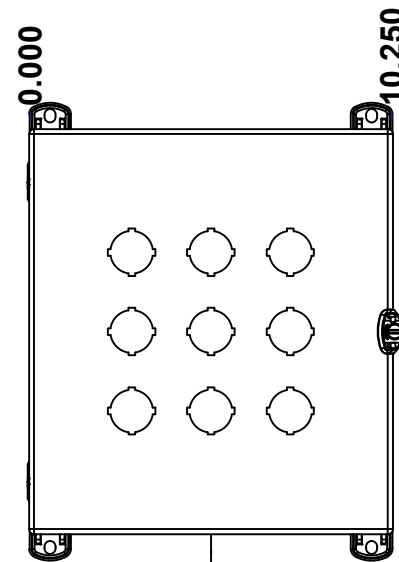

FRONT

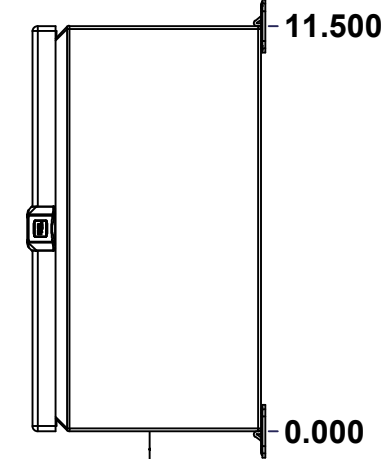

RIGHT

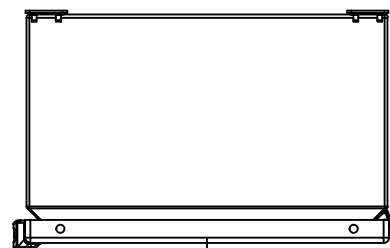

BOTTOM

No.	Revisions	Date	By/Par

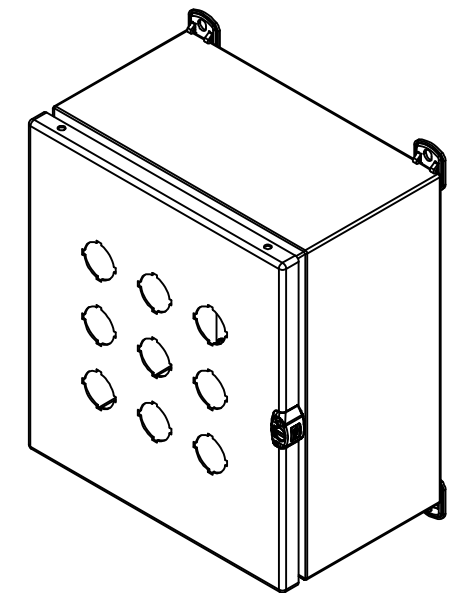

Isometric View



Tél: (450) 979-4373
 Fax: (450) 979-4626
www.exmweb.com

Flatness
Aplatissement

Max 3.0mm

Projection

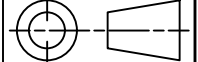

Customer Client	Date
Drawn By Dessiné Par BoxCad: BoxCad	Date 11-Jul-25
Material Matière 16 Ga Cold Rolled A1008 CS Type B (1.4mm)	

Color Couleur Asa-61 Grey	Finish Fini Smooth
------------------------------	-----------------------

Description 1412EL 11.5" x 10.25" x 6" Assembly	Detail Rev.
--	-------------

Part Number Numéro Pièce 1412EL111006	Rev. 0	1 9
---	---------------	--------

SEE BILL OF MATERIAL ON LAST PAGE

This drawing is confidential and must not be reproduced or used without the consent of EXM

Ce dessin est confidentiel et ne doit pas être reproduit ou utilisé sans le consentement de EXM

NOTE	
ITEM	DESCRIPTION
1	NEMA 4, 12 Enclosure (IP66)
2	C/W Standard ground standoffs on box and cover
3	W/O Standard door stiffener
4	C/W Standard inner panel (Included)
5	C/W Standard inner panel mounting standoffs
6	C/W 885 ESCHMF1 Mounting Feet (Installed)

No.	Revisions	Date	By/Par

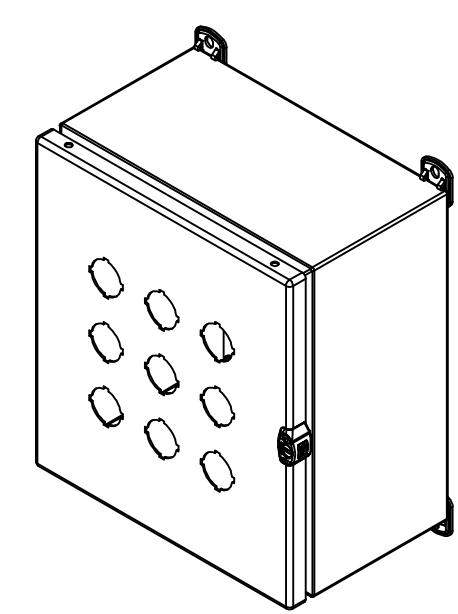

Isometric View



Tél: (450) 979-4373
 Fax: (450) 979-4626
www.exmweb.com

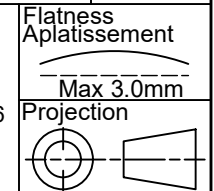

Customer Client	Date
Drawn By / Dessiné Par: BoxCad: BoxCad	Date: 11-Jul-25
Material / Matière: 16 Ga Cold Rolled A1008 CS Type B (1.4mm)	

Color / Couleur: Asa-61 Grey	Finish / Fini: Smooth
------------------------------	-----------------------

Description: 1412EL 11.5" x 10.25" x 6" Assembly	Detail Rev.
--	-------------

Part Number / Numéro Pièce: 1412EL111006	Rev. 0	2	9
---	--------	---	---

PACKING		
ITEM	QTY	DESCRIPTION
Cardboard sleeve	2	Top and Bottom
Cardboard strip	2	Between back of enclosure and inner panel
Plastic bag	1	To protect cover surface and inside gasket
Plastic strap - Black	2	To Squeeze the 2 cardboard sleeve together
Packaging label	1	White label with product number

Qty	Part Number	Rev	Description
1	1412EL111006C	0	1412EL 11.5" x 10.25" Cover
1	880 SP1008G	0	880 SP1008G - Inner Panel
1	STK-K-02910	3	5412 ESCH Accessory Kit
1	1412EL111006B	0	1412EL 11.5" x 10.25" x 6" Body
Parts List			

This drawing is confidential and must not be reproduced or used without the consent of EXM

Ce dessin est confidentiel et ne doit pas être reproduit ou utilisé sans le consentement de EXM

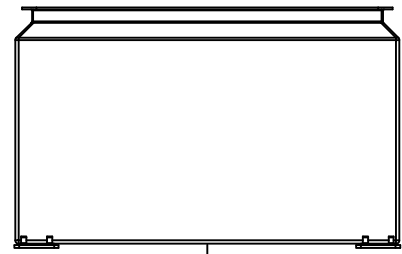

TOP

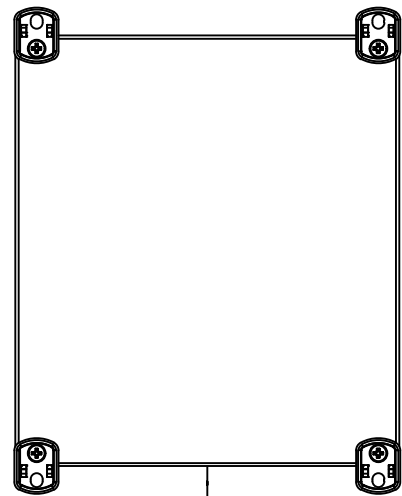

BACK

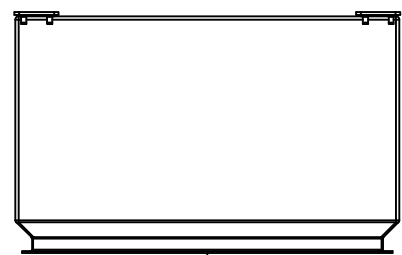

BOTTOM

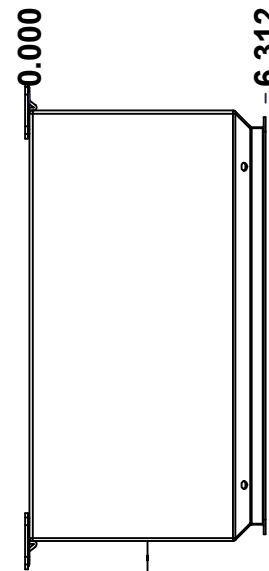

LEFT

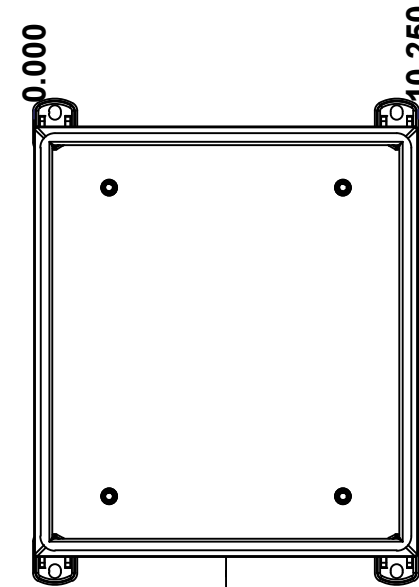

FRONT

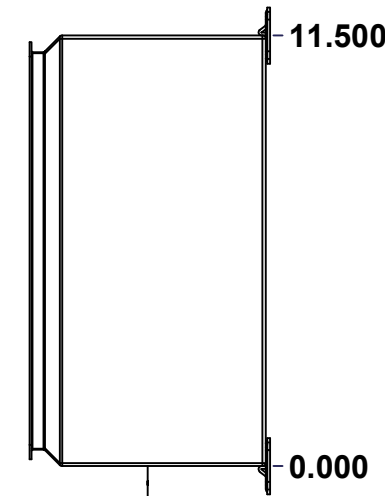

RIGHT

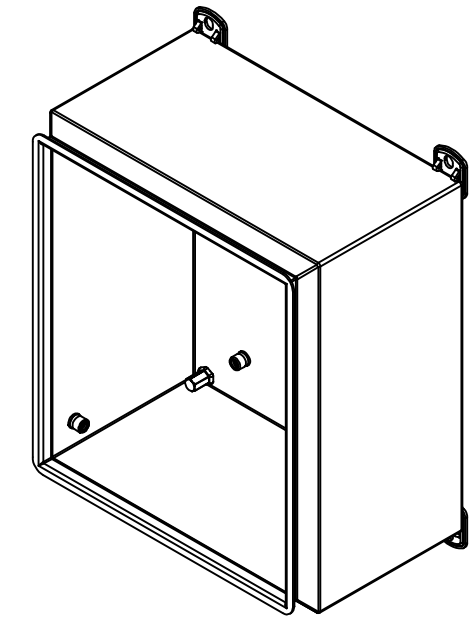

Isometric View

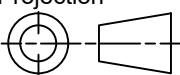

No.	Revisions	Date	By/Par

 Tél: (450) 979-4373 Fax: (450) 979-4626 www.exmweb.com		Flatness Aplatissement Max 3.0mm Projection 
Customer Client	Date	
Drawn By / Dessiné Par: BoxCad: BoxCad	Date: 11-Jul-25	
Material / Matière: 16 Ga Cold Rolled A1008 CS Type B (1.4mm)		
Color / Couleur: Asa-61 Grey	Finish / Fini: Smooth	
Description: 1412EL 11.5" x 10.25" x 6" Body	Detail Rev.	
Part Number / Numéro Pièce: 1412EL111006B	Rev. 0	3 / 9

SEE BILL OF MATERIAL ON LAST PAGE

This drawing is confidential and must not be reproduced or used without the consent of EXM

Ce dessin est confidentiel et ne doit pas être reproduit ou utilisé sans le consentement de EXM

STANDARD FEATURES ARE NOT LISTED IN THIS HOLE TABLE			
HOLE TABLE - LEFT VIEW (CUSTOM FEATURE ONLY)			
CUT-OUT	XDIM	YDIM	DESCRIPTION
1	4.625	0.875	STANDOFF M6 x 10mm (Inside)

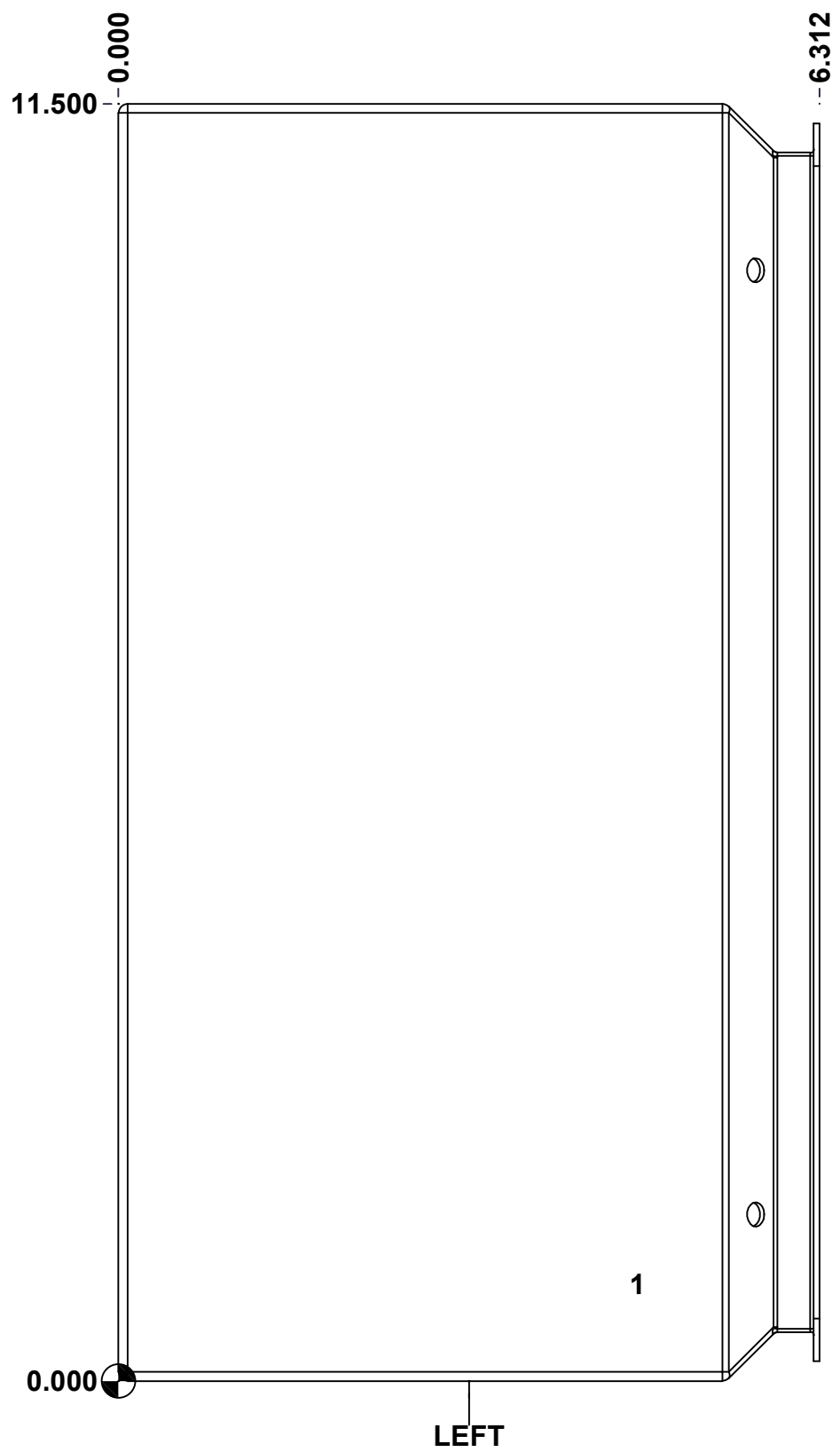

	Description	Status
	1412EL 11.5" x 10.25" x 6" Body	(NULL)
	Part Number Numéro Pièce	Rev.
	1412EL111006B	0 / 4 9

This drawing is confidential and must not be reproduced or used without the consent of EXM

Ce dessin est confidentiel et ne doit pas être reproduit ou utilisé sans le consentement de EXM

STANDARD FEATURES ARE NOT LISTED IN THIS HOLE TABLE

HOLE TABLE - BACK VIEW (CUSTOM FEATURE ONLY)

CUT-OUT	XDIM	YDIM	DESCRIPTION
1	2.000	1.625	IP STANDOFF M6 x 10mm (Inside)
2	2.000	9.875	IP STANDOFF M6 x 10mm (Inside)
3	8.250	9.875	IP STANDOFF M6 x 10mm (Inside)
4	8.250	1.625	IP STANDOFF M6 x 10mm (Inside)

5	0.563	0.000	FOOT 885 ESCHMF1
6	9.687	11.500	FOOT 885 ESCHMF1
7	0.563	11.500	FOOT 885 ESCHMF1
8	9.687	0.000	FOOT 885 ESCHMF1
9	0.563	0.344	RIVET NUT M6_FH_CE (Inside)
10	9.687	11.156	RIVET NUT M6_FH_CE (Inside)
11	0.563	11.156	RIVET NUT M6_FH_CE (Inside)
12	9.687	0.344	RIVET NUT M6_FH_CE (Inside)

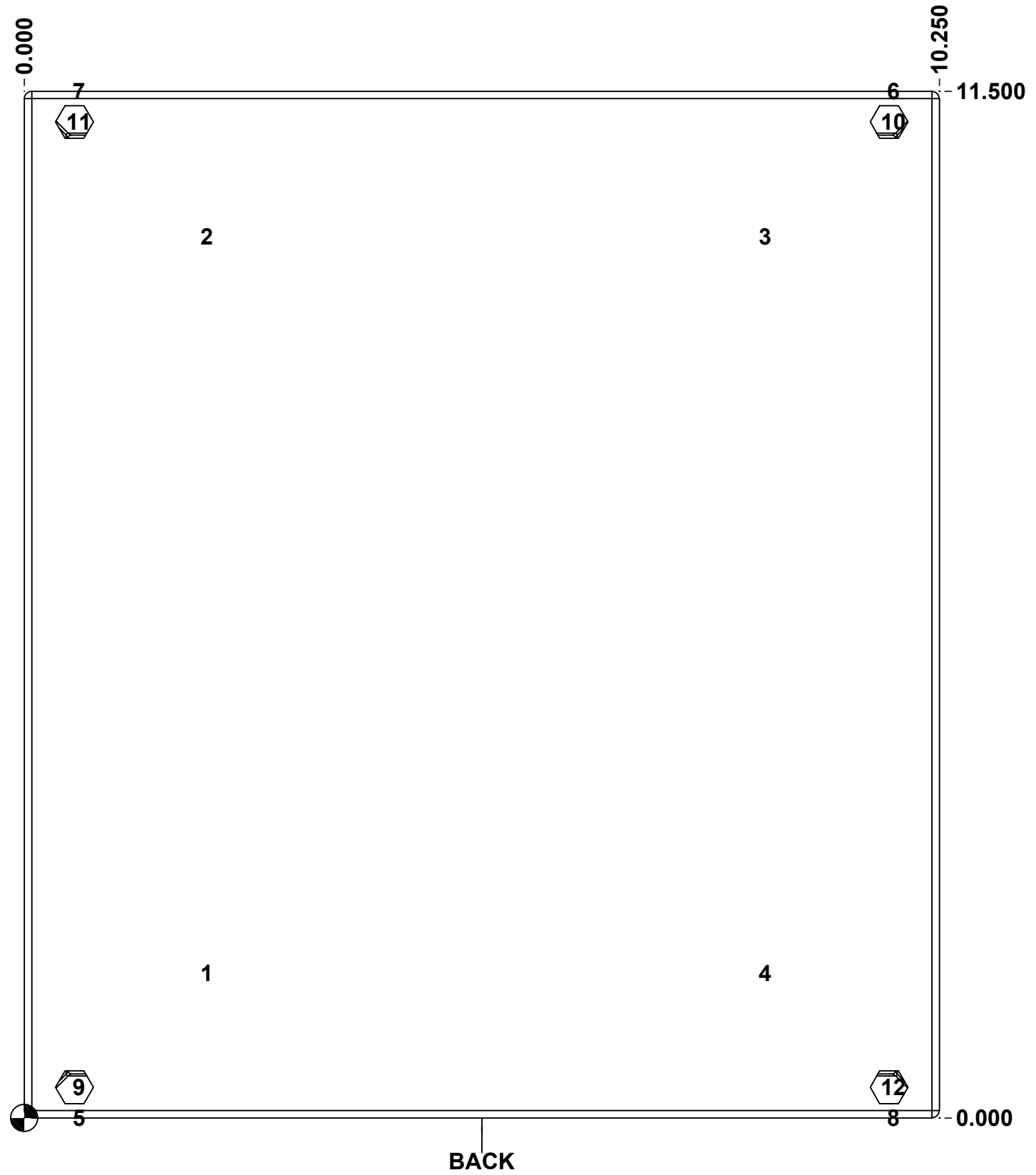

BACK

	Description	Status	
	1412EL 11.5" x 10.25" x 6" Body	(NULL)	
Part Number Numéro Pièce 1412EL111006B	Rev.	5	9
	0		

This drawing is confidential and must not be reproduced or used without the consent of EXM

Ce dessin est confidentiel et ne doit pas être reproduit ou utilisé sans le consentement de EXM

No.	Revisions	Date	By/Par

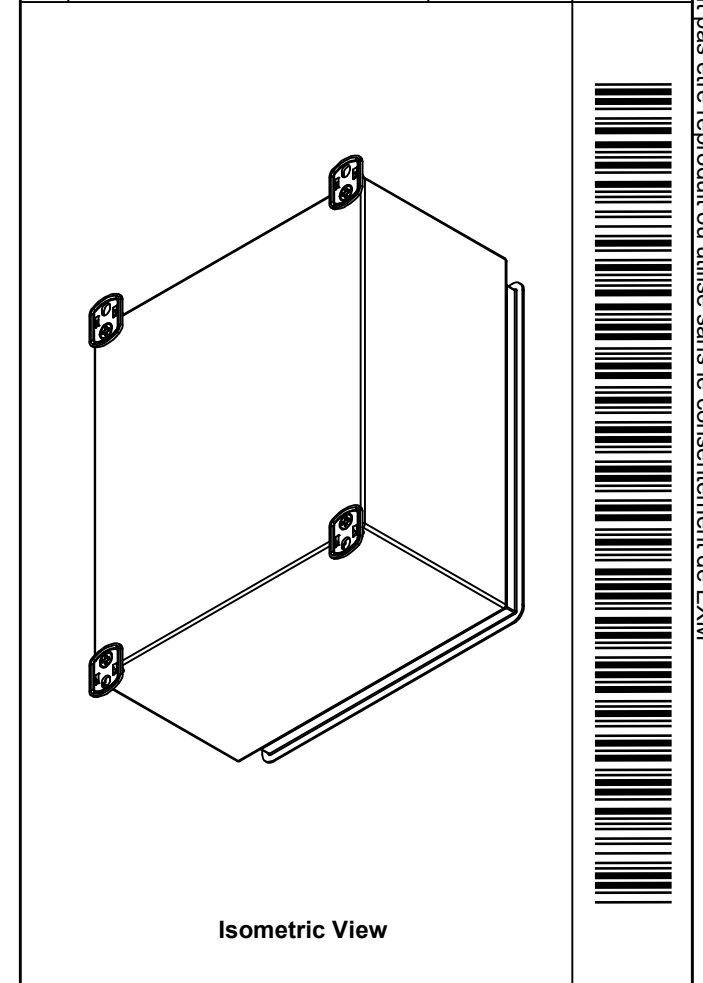

Tél: (450) 979-4373 Fax: (450) 979-4626 www.exmweb.com		Flatness Aplatissement	
		Max 3.0mm	
Customer Client		Date	
Drawn By Dessiné Par BoxCad: BoxCad		Date 11-Jul-25	
Material Matière 16 Ga Cold Rolled A1008 CS Type B (1.4mm)			
Color Couleur Asa-61 Grey		Finish Fini Smooth	
Description 1412EL 11.5" x 10.25" x 6" Body			Detail Rev.
Part Number Numéro Pièce 1412EL111006B			Rev. 0

4	RIVET_NUT_M6_FH_CE	0	Rivet Nut M6 (Low Profile Close End)
4	STK-Q-03071	0	M6 x 16mm Machine Screw
1	STK-P-02400S	0	Powder Paint (Asa-61 Grey / Smooth)
1	1412EL111006B-P	0	1412EL 11.5" x 10.25" x 6" Body Part
4	885 ESCHMF1	2	5412 ESCH Stamped Mounting Foot
5	STK-Q-08350	5	Standoff M6 x 10mm
Qty	Part Number	Rev	Description
Parts List			

This drawing is confidential and must not be reproduced or used without the consent of EXM

Ce dessin est confidentiel et ne doit pas être reproduit ou utilisé sans le consentement de EXM

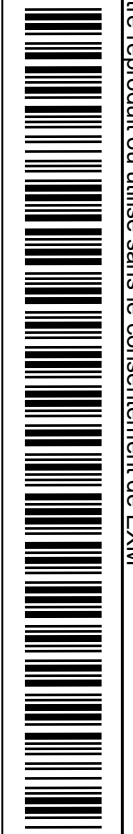
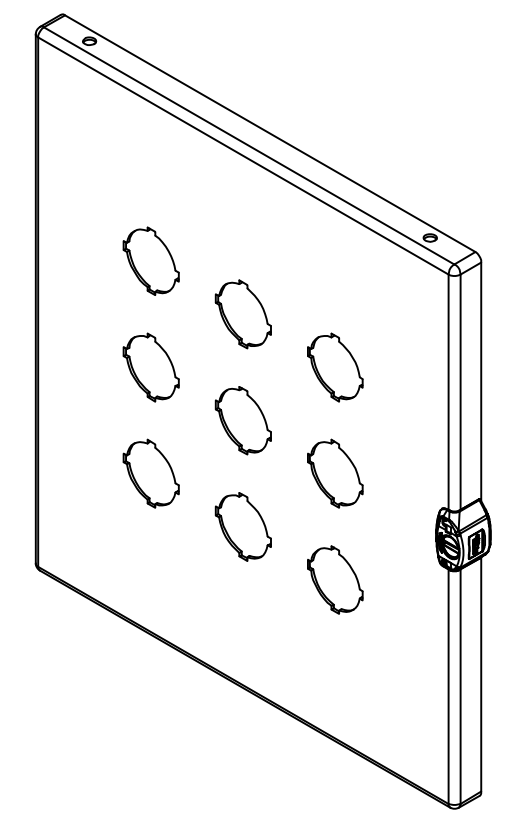
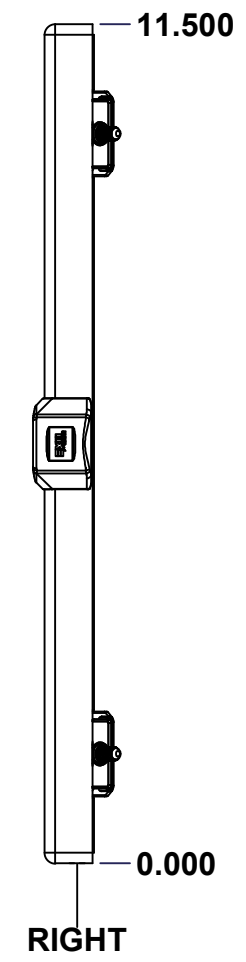
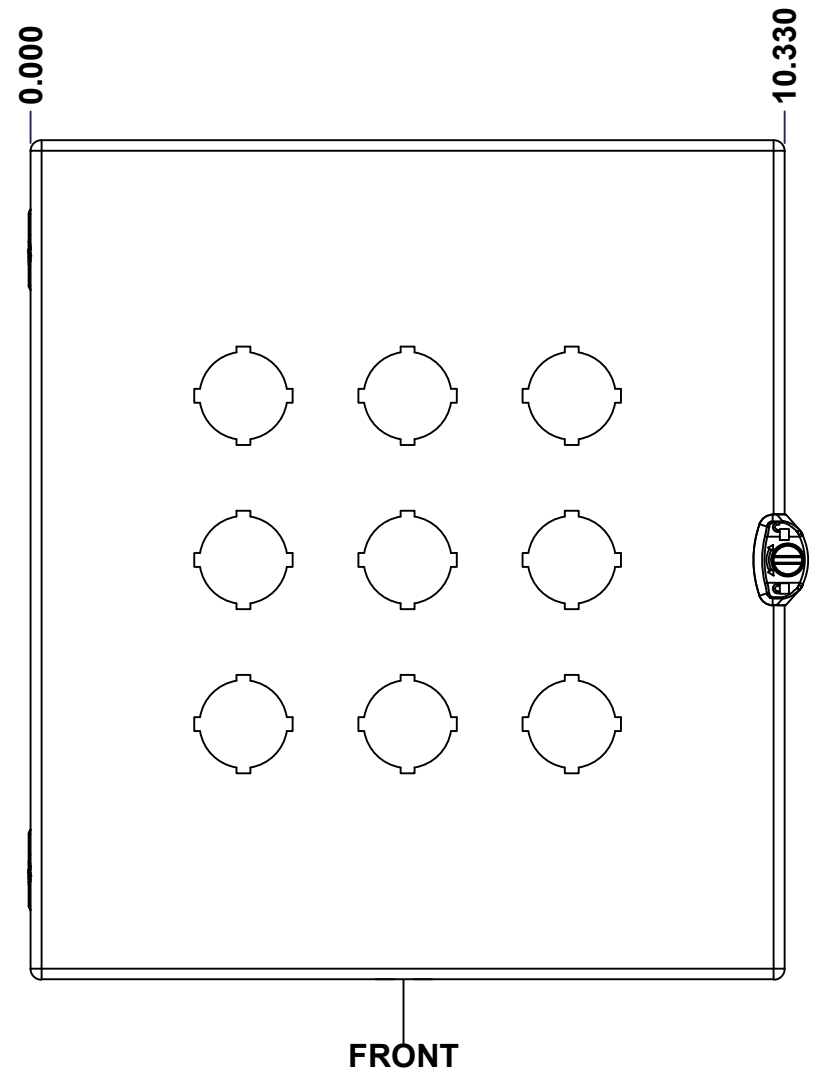
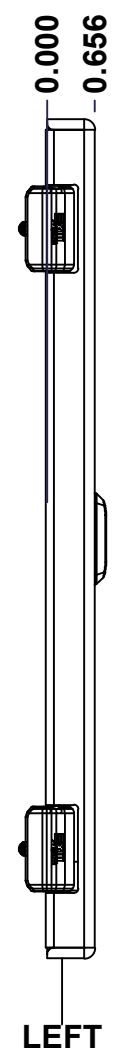
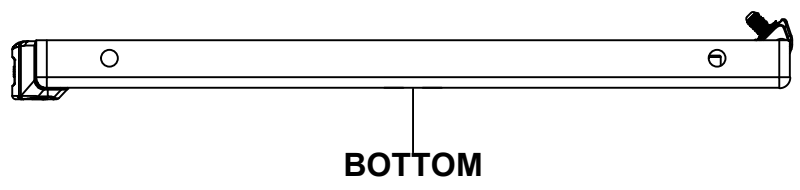
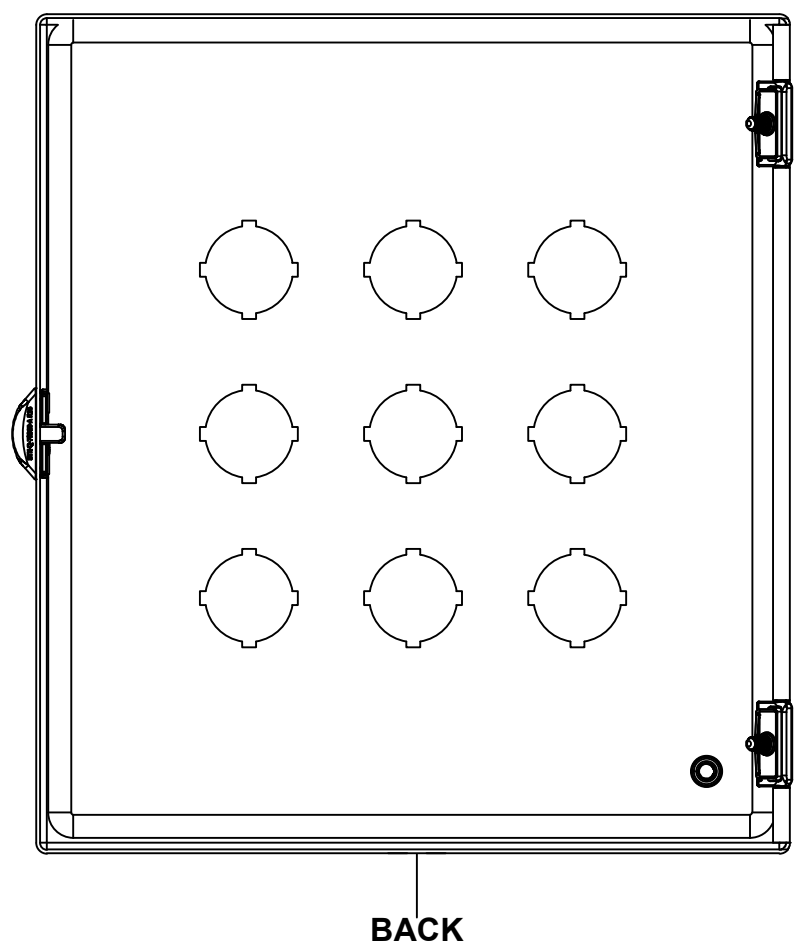
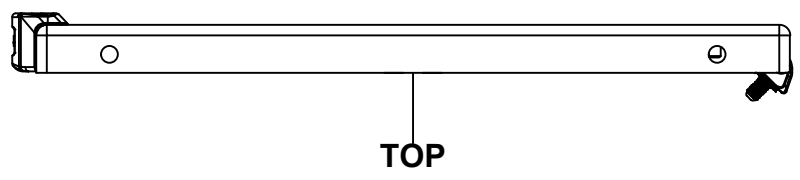

No.	Revisions	Date	By/Par

 Tél: (450) 979-4373 Fax: (450) 979-4626 www.exmweb.com		Flatness Aplatissement
		Max 3.0mm
Customer Client		Date
Drawn By Dessiné Par BoxCad: BoxCad		Date 11-Jul-25
Material Matière 16 Ga Cold Rolled A1008 CS Type B (1.4mm)		
Color Couleur Asa-61 Grey	Finish Fini Smooth	
Description 1412EL 11.5" x 10.25" Cover		Detail Rev.
Part Number Numéro Pièce 1412EL111006C		Rev. 7 0

SEE BILL OF MATERIAL ON LAST PAGE

This drawing is confidential and must not be reproduced or used without the consent of EXM

Ce dessin est confidentiel et ne doit pas être reproduit ou utilisé sans le consentement de EXM

STANDARD FEATURES ARE NOT LISTED IN THIS HOLE TABLE

HOLE TABLE - FRONT VIEW (CUSTOM FEATURE ONLY)

CUT-OUT	XDIM	YDIM	DESCRIPTION
1	7.415	3.500	30.5 mm Standard Pushbutton
2	7.415	5.750	30.5 mm Standard Pushbutton
3	7.415	8.000	30.5 mm Standard Pushbutton
4	5.165	3.500	30.5 mm Standard Pushbutton
5	5.165	5.750	30.5 mm Standard Pushbutton
6	5.165	8.000	30.5 mm Standard Pushbutton
7	2.915	3.500	30.5 mm Standard Pushbutton
8	2.915	5.750	30.5 mm Standard Pushbutton
9	2.915	8.000	30.5 mm Standard Pushbutton
10	1.145	1.125	STANDOFF M6 x 10mm (Inside)
11	10.330	5.750	LOCK 880 SCQ2MS @ 0.0°

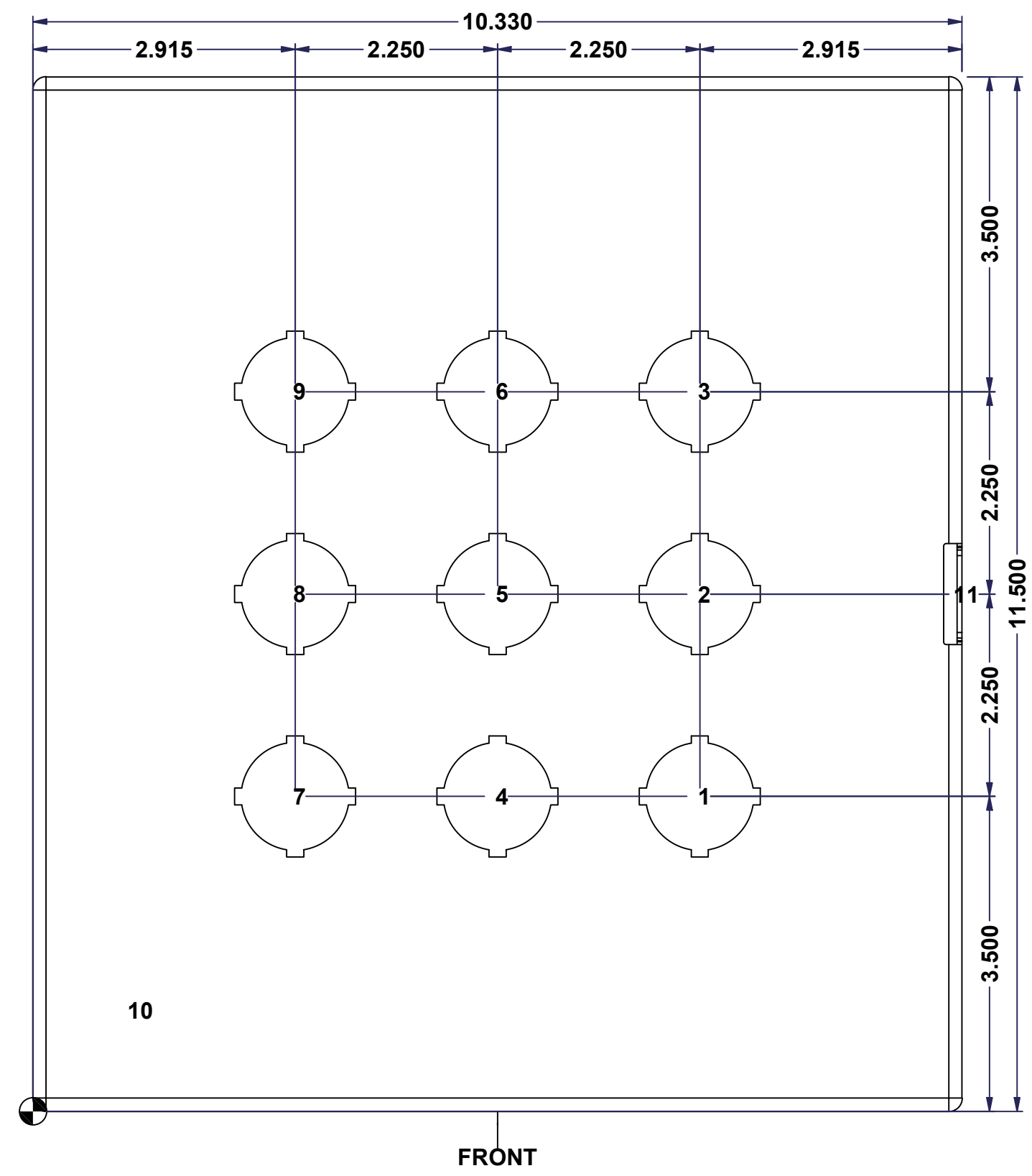

FRONT

	Description	Status
	1412EL 11.5" x 10.25" Cover	(NULL)
	Part Number	Rev.
	1412EL111006C	8
		0
		9

This drawing is confidential and must not be reproduced or used without the consent of EXM

Ce dessin est confidentiel et ne doit pas être reproduit ou utilisé sans le consentement de EXM

No.	Revisions	Date	By/Par

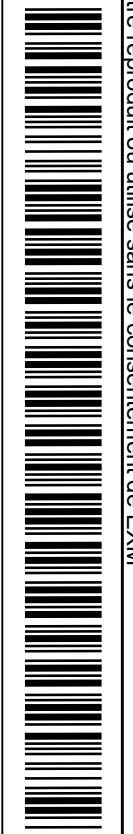
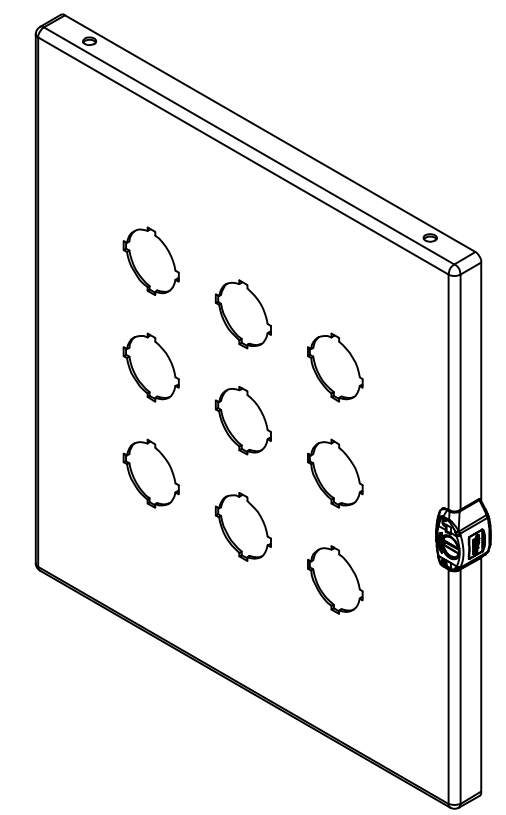

Isometric View

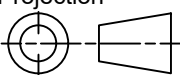
 Tél: (450) 979-4373 Fax: (450) 979-4626 www.exmweb.com	Flatness Aplatissement	Max 3.0mm
	Projection	
Customer Client	Date	
Drawn By Dessiné Par	BoxCad: BoxCad	Date 11-Jul-25
Material Matière	16 Ga Cold Rolled A1008 CS Type B (1.4mm)	
Color Couleur	Asa-61 Grey	Finish Fini Smooth
Description	Detail Rev.	
1412EL 11.5" x 10.25" Cover		
Part Number Numéro Pièce	Rev.	9
1412EL111006C	0	9

Qty	Part Number	Rev	Description
1	1412EL111006G	0	1412EL 11.5" x 10.25" Gasket
1	STK-A-79960	14	5412 ESMCH - External Lock Assy - Slot Lock
1	STK-Q-08350	5	Standoff M6 x 10mm
1	STK-P-02400S	0	Powder Paint (Asa-61 Grey / Smooth)
1	1412EL111006C-P	0	1412EL 11.5" x 10.25" Cover Part
2	STK-A-33033	4	5412 ESMCH Hinge
Parts List			

This drawing is confidential and must not be reproduced or used without the consent of EXM

Ce dessin est confidentiel et ne doit pas être reproduit ou utilisé sans le consentement de EXM

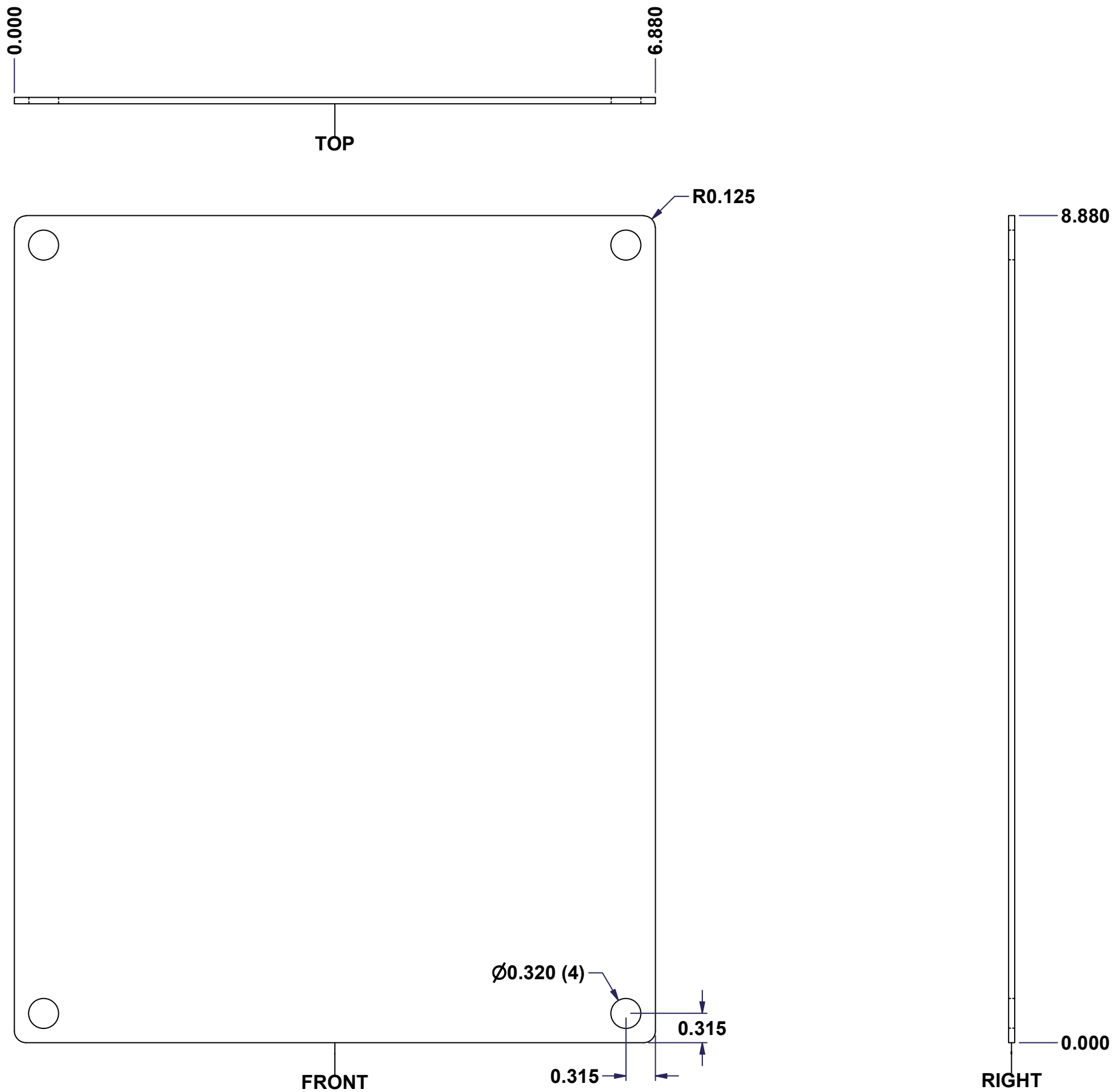

No.	Revisions	Date	By/Par

Isometric View

<p>Tél: (450) 979-4373 Fax: (450) 979-4626 www.exmweb.com</p>	Flatness Aplatissement	Max 3.0mm
	Projection	
Customer Client	Date	
Drawn By Dessiné Par	BoxCad	Date 23-Jan-07
Material Matière	14 Ga Galvanized (1.7mm)	
Color Couleur	Unpainted	Finish Fini Galvanized
Description	880 SP1008G - Inner Panel	
Part Number Numéro Pièce	Rev. 0	1 2

SEE BILL OF MATERIAL ON LAST PAGE

This drawing is confidential and must not be reproduced or used without the consent of EXM

Ce dessin est confidentiel et ne doit pas être reproduit ou utilisé sans le consentement de EXM

No.	Revisions	Date	By/Par

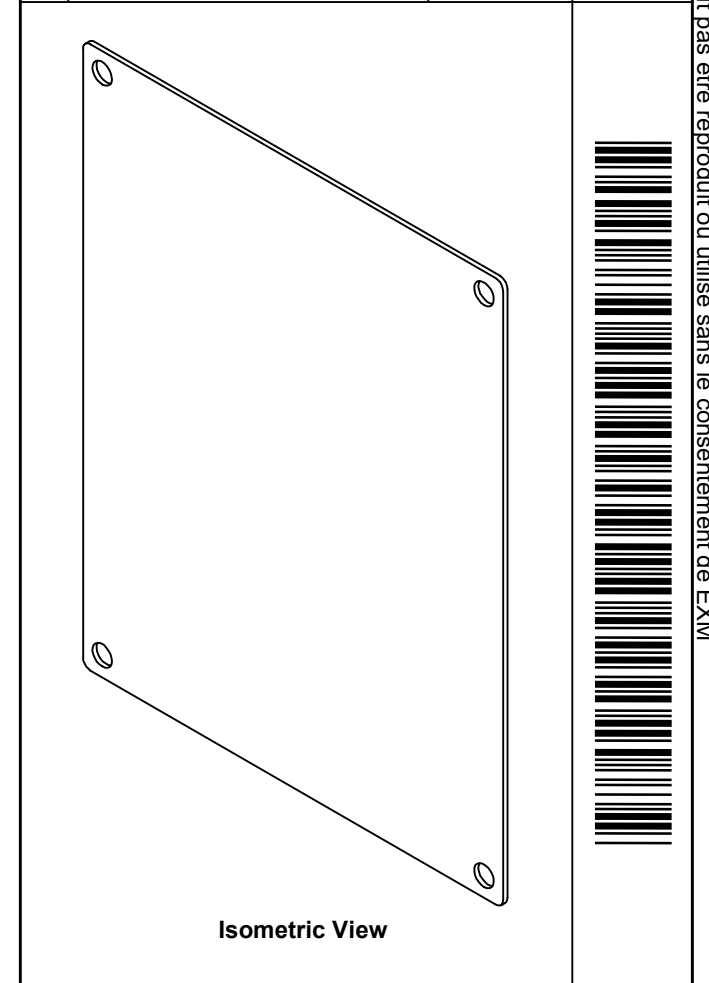

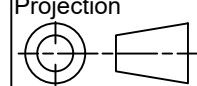
 Tél: (450) 979-4373 Fax: (450) 979-4626 www.exmweb.com		Flatness Aplatissement Max 3.0mm
Customer Client		Projection 
Drawn By / Dessiné Par: BoxCad		Date: 23-Jan-07
Material / Matière: 14 Ga Galvanized (1.7mm)		
Color / Couleur: Unpainted	Finish / Fini: Galvanized	
Description: 880 SP1008G - Inner Panel		Detail Rev.
Part Number / Numéro Pièce: 880 SP1008G		Rev. 0 / 2

Qty	Part Number	Rev.	Description
1	880SP1008G-P	0	880 SP1008G - Inner Panel Part
Parts List			