

This drawing is confidential and must not be reproduced or used without the consent of EXM

Ce dessin est confidentiel et ne doit pas être reproduit ou utilisé sans le consentement de EXM

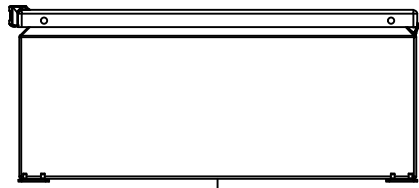

TOP

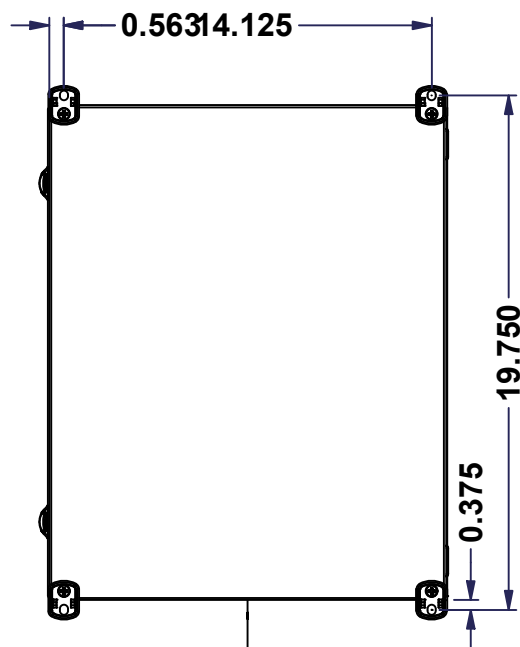

BACK

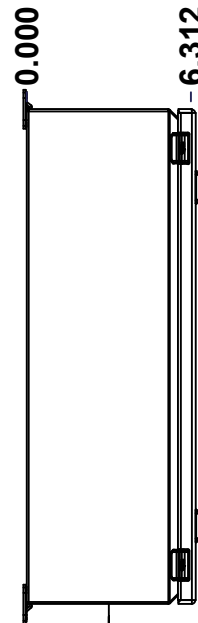

LEFT

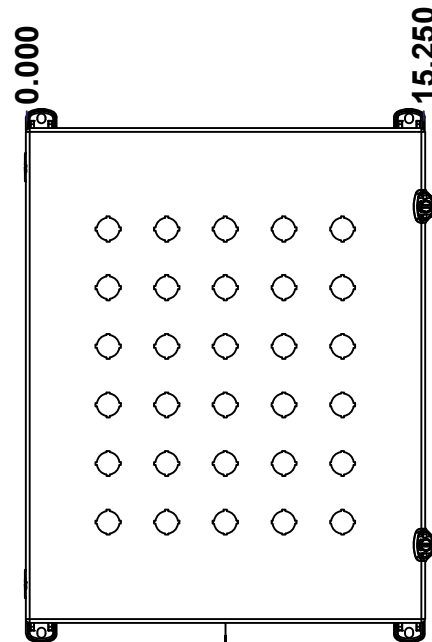

FRONT

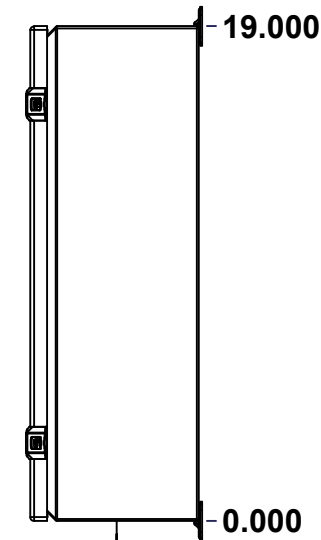

RIGHT

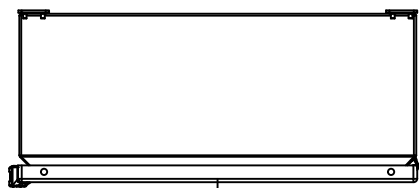

BOTTOM

No.	Revisions	Date	By/Par

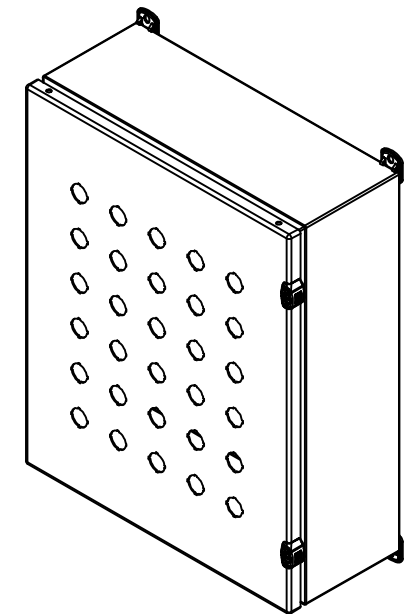

Isometric View



Tél: (450) 979-4373
 Fax: (450) 979-4626
www.exmweb.com

Flatness
Aplatissement
Max 3.0mm
Projection

Customer Client	Date
Drawn By Dessiné Par BoxCad: BoxCad	Date 11-Jul-25
Material Matière 16 Ga Cold Rolled A1008 CS Type B (1.4mm)	

Color Couleur Asa-61 Grey	Finish Fini Smooth
------------------------------	-----------------------

Description 1412ELMN 19" x 15.25" x 6" Assembly	Detail Rev.
--	-------------

Part Number Numéro Pièce 1412EL181506MN	Rev. 0	1
--	--------	---

SEE BILL OF MATERIAL ON LAST PAGE

This drawing is confidential and must not be reproduced or used without the consent of EXM

Ce dessin est confidentiel et ne doit pas être reproduit ou utilisé sans le consentement de EXM

NOTE	
ITEM	DESCRIPTION
1	NEMA 4, 12 Enclosure (IP66)
2	C/W Standard ground standoffs on box and cover
3	W/O Standard door stiffener
4	C/W Special inner panel (Sold separately)
5	C/W Standard inner panel mounting standoffs
6	C/W 885 ESCHMF1 Mounting Feet (Installed)

No.	Revisions	Date	By/Par

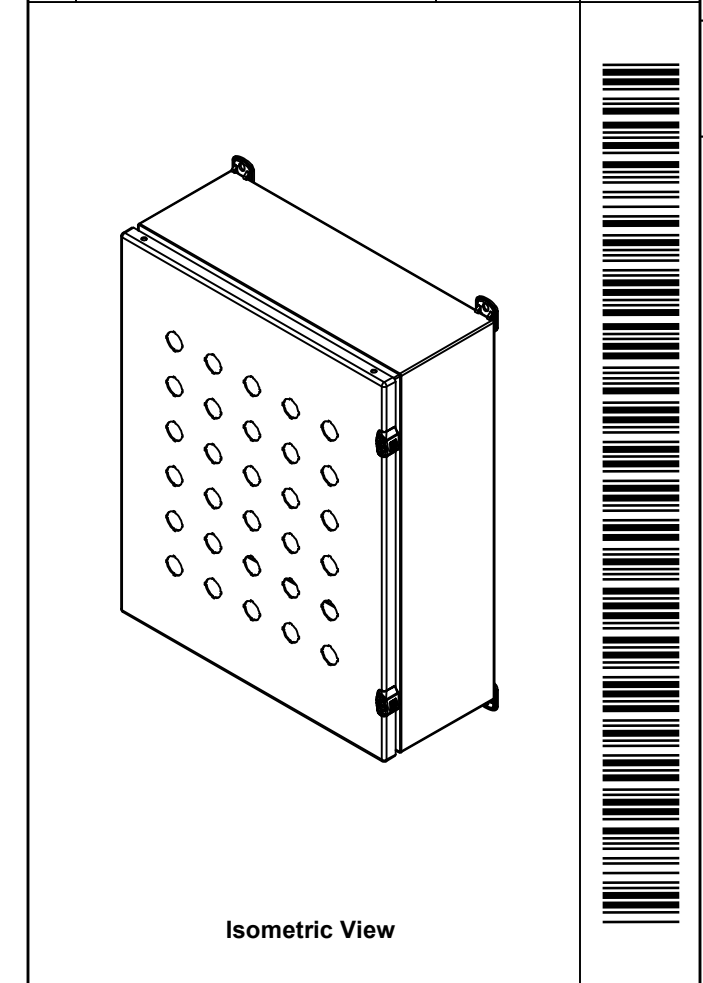

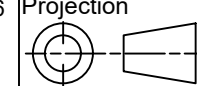
 Tél: (450) 979-4373 Fax: (450) 979-4626 www.exmweb.com	Flatness Aplatissement Max 3.0mm
	Projection 
Customer Client	Date
Drawn By Dessiné Par BoxCad: BoxCad	Date 11-Jul-25
Material Matière 16 Ga Cold Rolled A1008 CS Type B (1.4mm)	
Color Couleur Asa-61 Grey	Finish Fini Smooth
Description 1412ELMN 19" x 15.25" x 6" Assembly	
Part Number Numéro Pièce 1412EL181506MN	Rev. 2 0 / 11

PACKING		
ITEM	QTY	DESCRIPTION
Cardboard sleeve	2	Top and Bottom
Cardboard strip	2	Between back of enclosure and inner panel
Plastic bag	1	To protect cover surface and inside gasket
Plastic strap - Black	2	To Squeeze the 2 cardboard sleeve together
Packaging label	1	White label with product number

Qty	Part Number	Rev	Description
1	1412EL181506MNC	0	1412ELMN 19" x 15.25" Cover
1	1412EL181506MNIP	0	1412EL 19" x 15.25" Inner Panel
1	STK-K-02910	3	5412 ESCH Accessory Kit
1	1412EL181506MNB	0	1412ELMN 19" x 15.25" x 6" Body
Parts List			

This drawing is confidential and must not be reproduced or used without the consent of EXM

Ce dessin est confidentiel et ne doit pas être reproduit ou utilisé sans le consentement de EXM

No.	Revisions	Date	By/Par

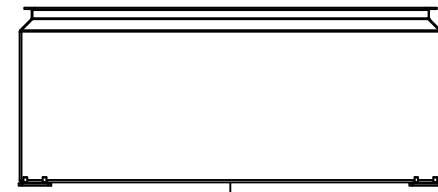

TOP



BACK

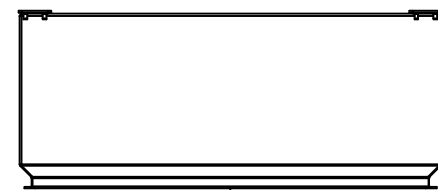

BOTTOM

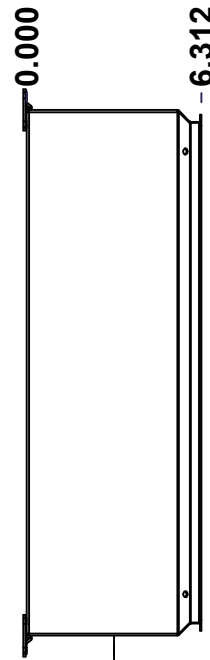

LEFT

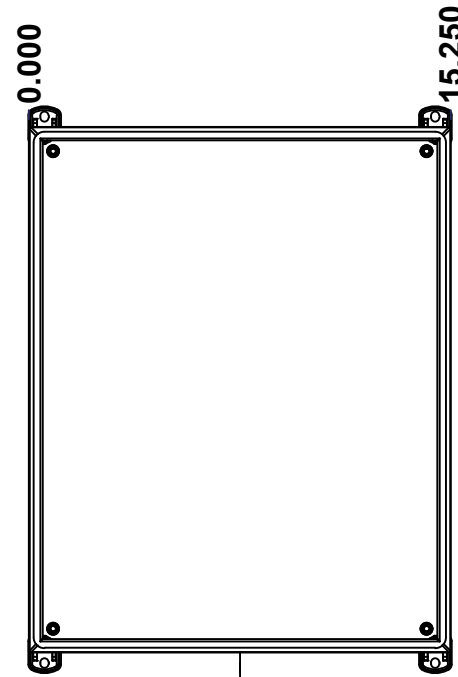

FRONT

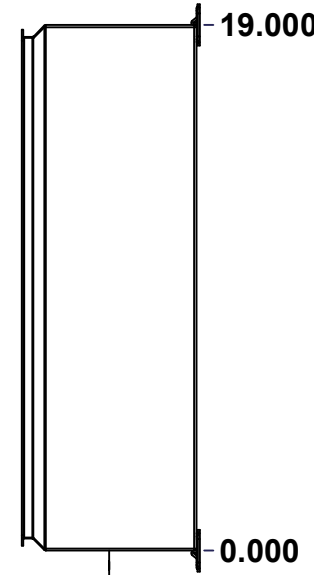

RIGHT

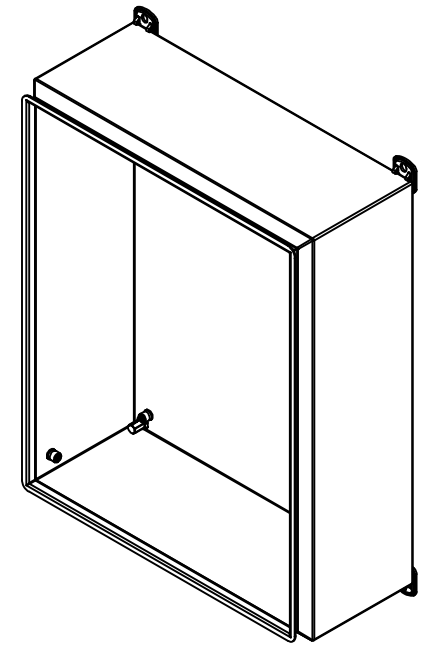

Isometric View



Tél: (450) 979-4373
 Fax: (450) 979-4626
www.exmweb.com

Flatness
 Aplatissement
 Max 3.0mm
 Projection

Customer Client	Date
Drawn By / Dessiné Par: BoxCad: BoxCad	Date: 11-Jul-25
Material / Matière: 16 Ga Cold Rolled A1008 CS Type B (1.4mm)	

Color / Couleur: Asa-61 Grey	Finish / Fini: Smooth
------------------------------	-----------------------

Description: 1412ELMN 19" x 15.25" x 6" Body	Detail Rev.
--	-------------

Part Number / Numéro Pièce: 1412EL181506MNB	Rev. 0	3
---	--------	---

SEE BILL OF MATERIAL ON LAST PAGE

This drawing is confidential and must not be reproduced or used without the consent of EXM

Ce dessin est confidentiel et ne doit pas être reproduit ou utilisé sans le consentement de EXM

STANDARD FEATURES ARE NOT LISTED IN THIS HOLE TABLE			
HOLE TABLE - LEFT VIEW (CUSTOM FEATURE ONLY)			
CUT-OUT	XDIM	YDIM	DESCRIPTION
1	4.625	0.875	STANDOFF M6 x 10mm (Inside)

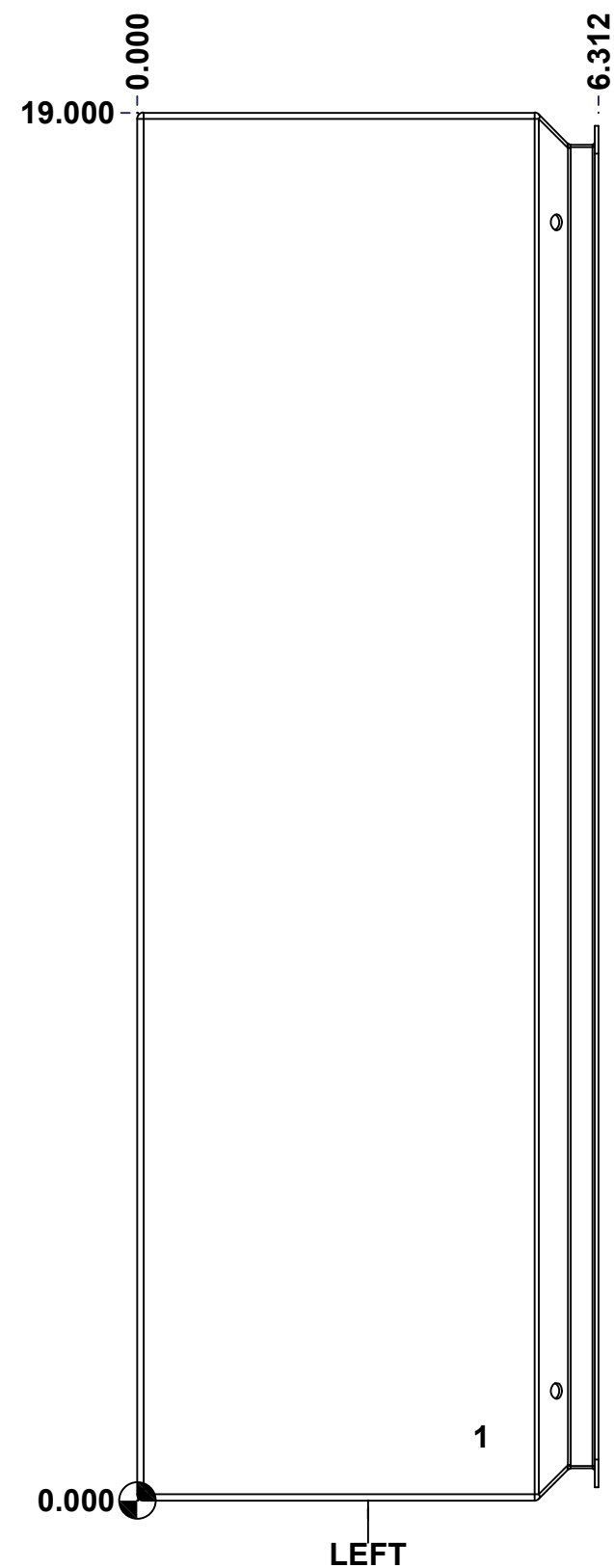

	Description	Status	
	1412EL 19" x 15.25" x 6" Body	(NULL)	
	Part Number Numéro Pièce	Rev.	4
	1412EL181506MNB	0	11

This drawing is confidential and must not be reproduced or used without the consent of EXM

Ce dessin est confidentiel et ne doit pas être reproduit ou utilisé sans le consentement de EXM

STANDARD FEATURES ARE NOT LISTED IN THIS HOLE TABLE

HOLE TABLE - BACK VIEW (CUSTOM FEATURE ONLY)

CUT-OUT	XDIM	YDIM	DESCRIPTION
1	0.875	0.875	IP STANDOFF M6 x 10mm (Inside)
2	0.875	18.125	IP STANDOFF M6 x 10mm (Inside)
3	14.375	18.125	IP STANDOFF M6 x 10mm (Inside)
4	14.375	0.875	IP STANDOFF M6 x 10mm (Inside)

5	14.687	19.000	FOOT 885 ESCHMF1
6	0.563	19.000	FOOT 885 ESCHMF1
7	14.687	0.000	FOOT 885 ESCHMF1
8	0.563	0.000	FOOT 885 ESCHMF1
9	14.687	18.656	RIVET NUT M6_FH_CE (Inside)
10	0.563	18.656	RIVET NUT M6_FH_CE (Inside)
11	14.687	0.344	RIVET NUT M6_FH_CE (Inside)
12	0.563	0.344	RIVET NUT M6_FH_CE (Inside)

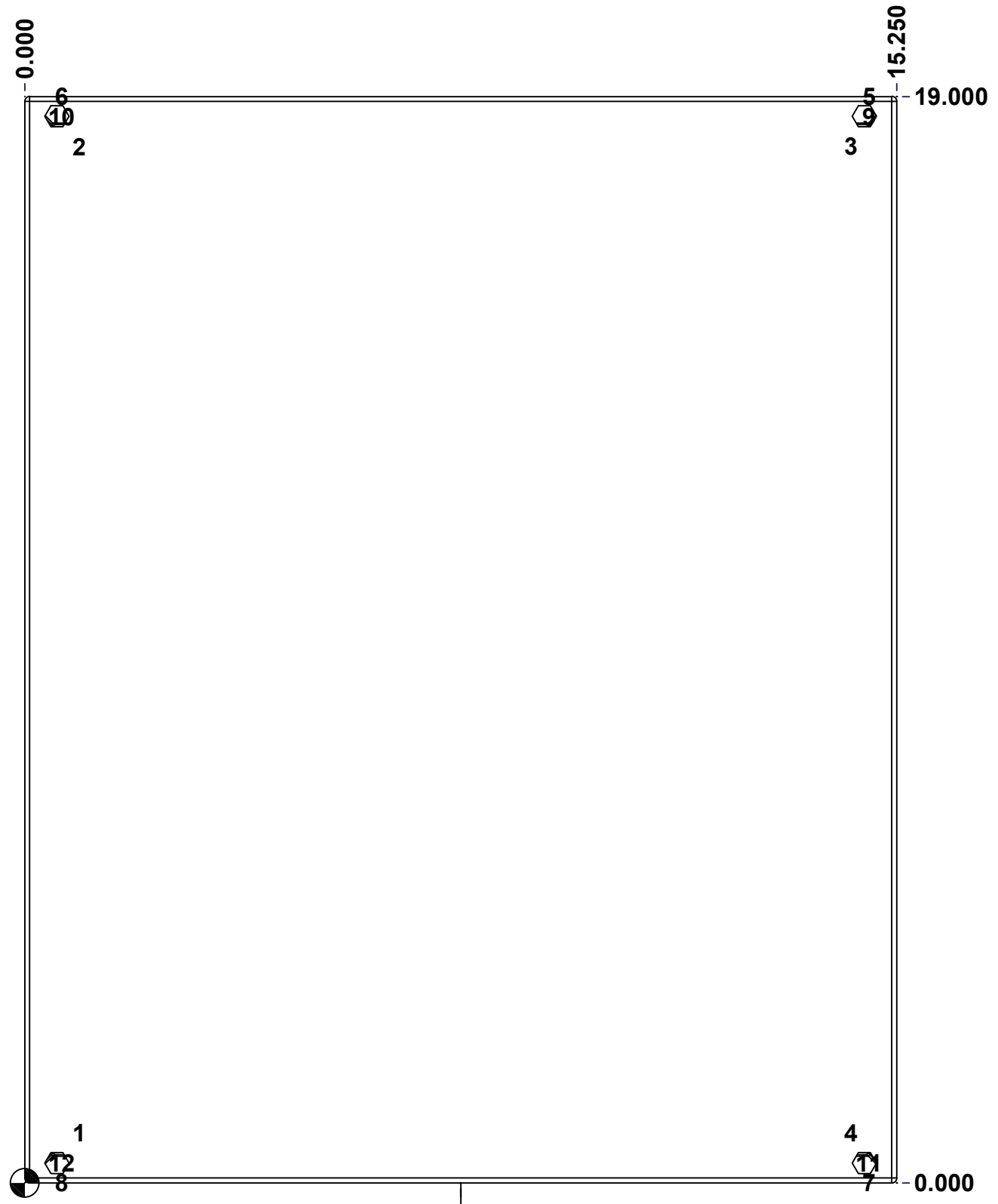

BACK

	Description	Status
	1412EL 19" x 15.25" x 6" Body	(NULL)
	Part Number Numéro Pièce	Rev.
	1412EL181506MNB	0 / 5
		11

This drawing is confidential and must not be reproduced or used without the consent of EXM

Ce dessin est confidentiel et ne doit pas être reproduit ou utilisé sans le consentement de EXM

No.	Revisions	Date	By/Par

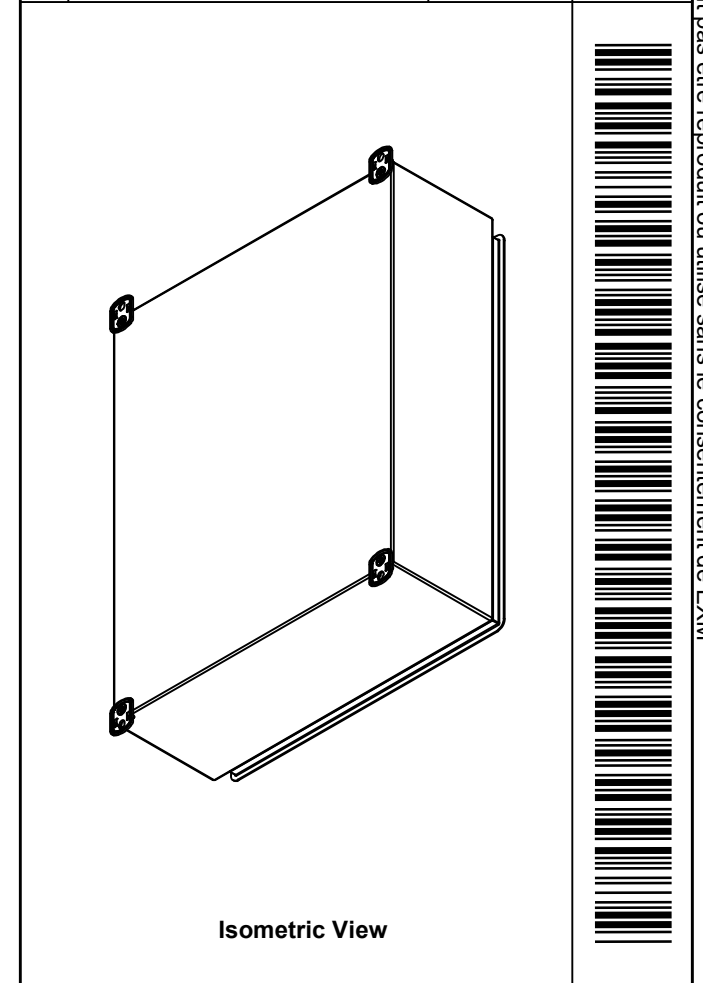

Tél: (450) 979-4373 Fax: (450) 979-4626 www.exmweb.com		Flatness Aplatissement	
		Max 3.0mm	
Customer Client		Date	
Drawn By Dessiné Par BoxCad: BoxCad		Date 11-Jul-25	
Material Matière 16 Ga Cold Rolled A1008 CS Type B (1.4mm)			
Color Couleur Asa-61 Grey		Finish Fini Smooth	
Description 1412ELMN 19" x 15.25" x 6" Body			Detail Rev.
Part Number Numéro Pièce 1412EL181506MNB			Rev. 0

Qty	Part Number	Rev	Description
4	RIVET_NUT_M6_FH_CE	0	Rivet Nut M6 (Low Profile Close End)
4	STK-Q-03071	0	M6 x 16mm Machine Screw
1	STK-P-02400S	0	Powder Paint (Asa-61 Grey / Smooth)
1	1412EL181506MNB-P	0	1412EL 19" x 15.25" x 6" Body Part
4	885 ESCHMF1	2	5412 ESCH Stamped Mounting Foot
5	STK-Q-08350	5	Standoff M6 x 10mm
Parts List			

This drawing is confidential and must not be reproduced or used without the consent of EXM

Ce dessin est confidentiel et ne doit pas être reproduit ou utilisé sans le consentement de EXM

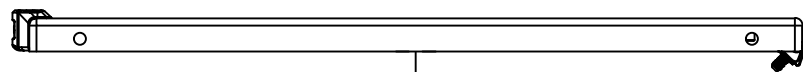

TOP

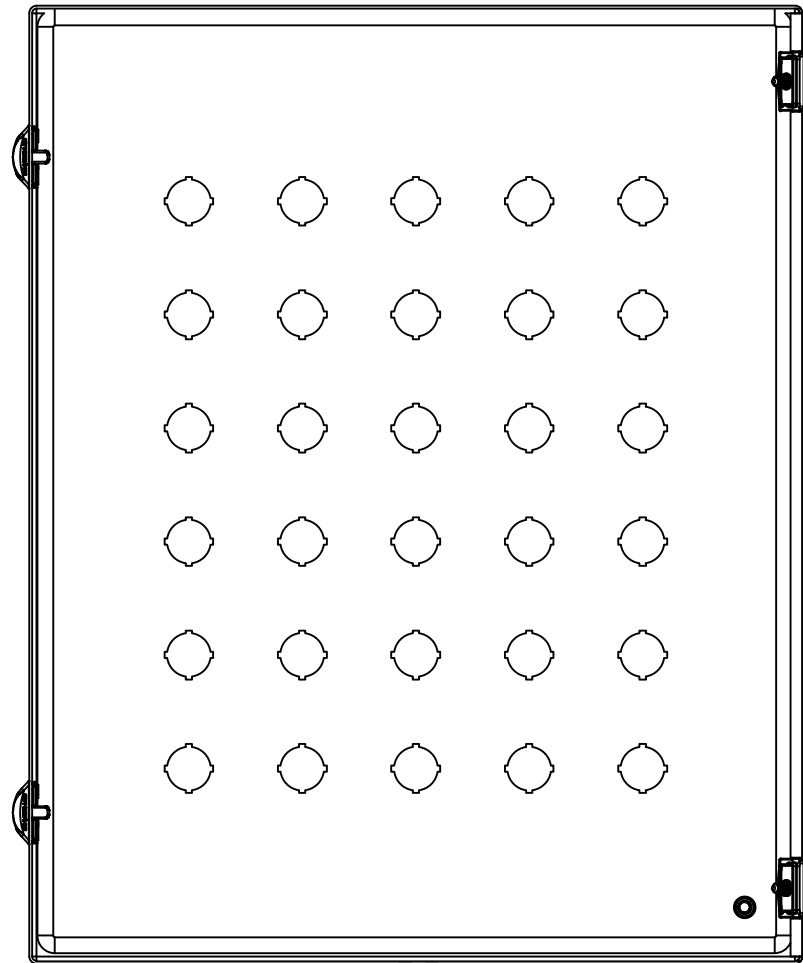

BACK

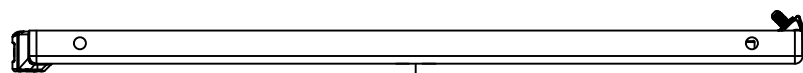

BOTTOM

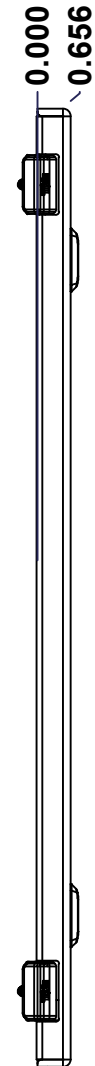

LEFT

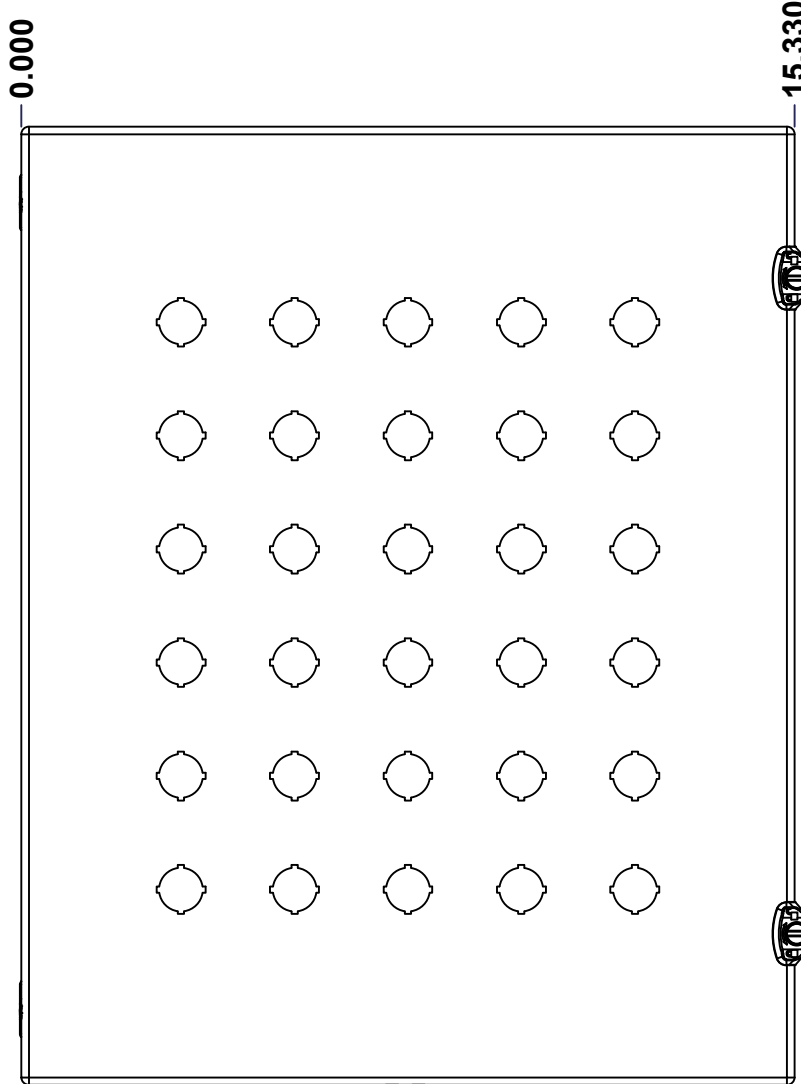

FRONT

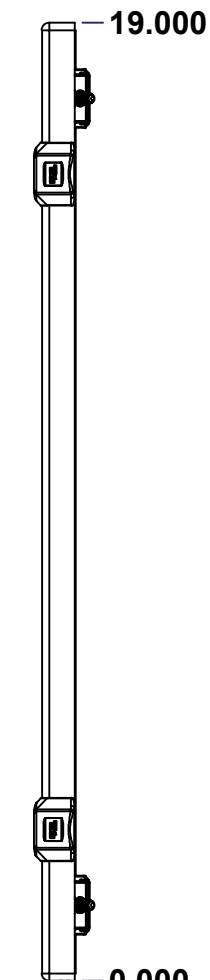

RIGHT

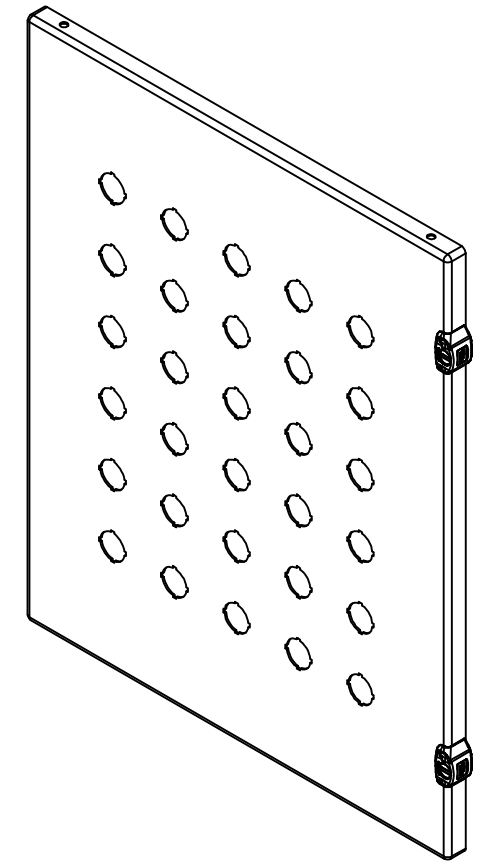

Isometric View

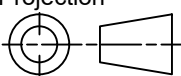

No.	Revisions	Date	By/Par

 Tél: (450) 979-4373 Fax: (450) 979-4626 www.exmweb.com		Flatness Aplatissement Max 3.0mm Projection 
Customer Client	Date	
Drawn By Dessiné Par	BoxCad: BoxCad	Date 11-Jul-25
Material Matière	16 Ga Cold Rolled A1008 CS Type B (1.4mm)	
Color Couleur	Asa-61 Grey	Finish Fini Smooth
Description 1412ELMN 19" x 15.25" Cover		Detail Rev.
Part Number Numéro Pièce	1412EL181506MNC	Rev. 7 0

SEE BILL OF MATERIAL ON LAST PAGE

This drawing is confidential and must not be reproduced or used without the consent of EXM

Ce dessin est confidentiel et ne doit pas être reproduit ou utilisé sans le consentement de EXM

STANDARD FEATURES ARE NOT LISTED IN THIS HOLE TABLE			
HOLE TABLE - FRONT VIEW (CUSTOM FEATURE ONLY)			
CUT-OUT	XDIM	YDIM	DESCRIPTION
1	7.665	15.125	22.5 mm Miniature Pushbutton
2	5.415	3.875	22.5 mm Miniature Pushbutton
3	5.415	6.125	22.5 mm Miniature Pushbutton
4	5.415	8.375	22.5 mm Miniature Pushbutton
5	5.415	10.625	22.5 mm Miniature Pushbutton
6	5.415	12.875	22.5 mm Miniature Pushbutton
7	5.415	15.125	22.5 mm Miniature Pushbutton
8	3.165	3.875	22.5 mm Miniature Pushbutton
9	3.165	6.125	22.5 mm Miniature Pushbutton
10	3.165	8.375	22.5 mm Miniature Pushbutton
11	3.165	10.625	22.5 mm Miniature Pushbutton
12	3.165	12.875	22.5 mm Miniature Pushbutton
13	3.165	15.125	22.5 mm Miniature Pushbutton
14	12.165	3.875	22.5 mm Miniature Pushbutton
15	12.165	6.125	22.5 mm Miniature Pushbutton
16	12.165	8.375	22.5 mm Miniature Pushbutton
17	12.165	10.625	22.5 mm Miniature Pushbutton
18	12.165	12.875	22.5 mm Miniature Pushbutton
19	12.165	15.125	22.5 mm Miniature Pushbutton
20	9.915	3.875	22.5 mm Miniature Pushbutton
21	9.915	6.125	22.5 mm Miniature Pushbutton
22	9.915	8.375	22.5 mm Miniature Pushbutton
23	9.915	10.625	22.5 mm Miniature Pushbutton
24	9.915	12.875	22.5 mm Miniature Pushbutton
25	9.915	15.125	22.5 mm Miniature Pushbutton
26	7.665	3.875	22.5 mm Miniature Pushbutton
27	7.665	6.125	22.5 mm Miniature Pushbutton
28	7.665	8.375	22.5 mm Miniature Pushbutton
29	7.665	10.625	22.5 mm Miniature Pushbutton
30	7.665	12.875	22.5 mm Miniature Pushbutton
31	1.145	1.125	STANDOFF M6 x 10mm (Inside)
32	15.330	16.000	LOCK 880 SCQ2MS @ 0.0°
33	15.330	3.000	LOCK 880 SCQ2MS @ 0.0°

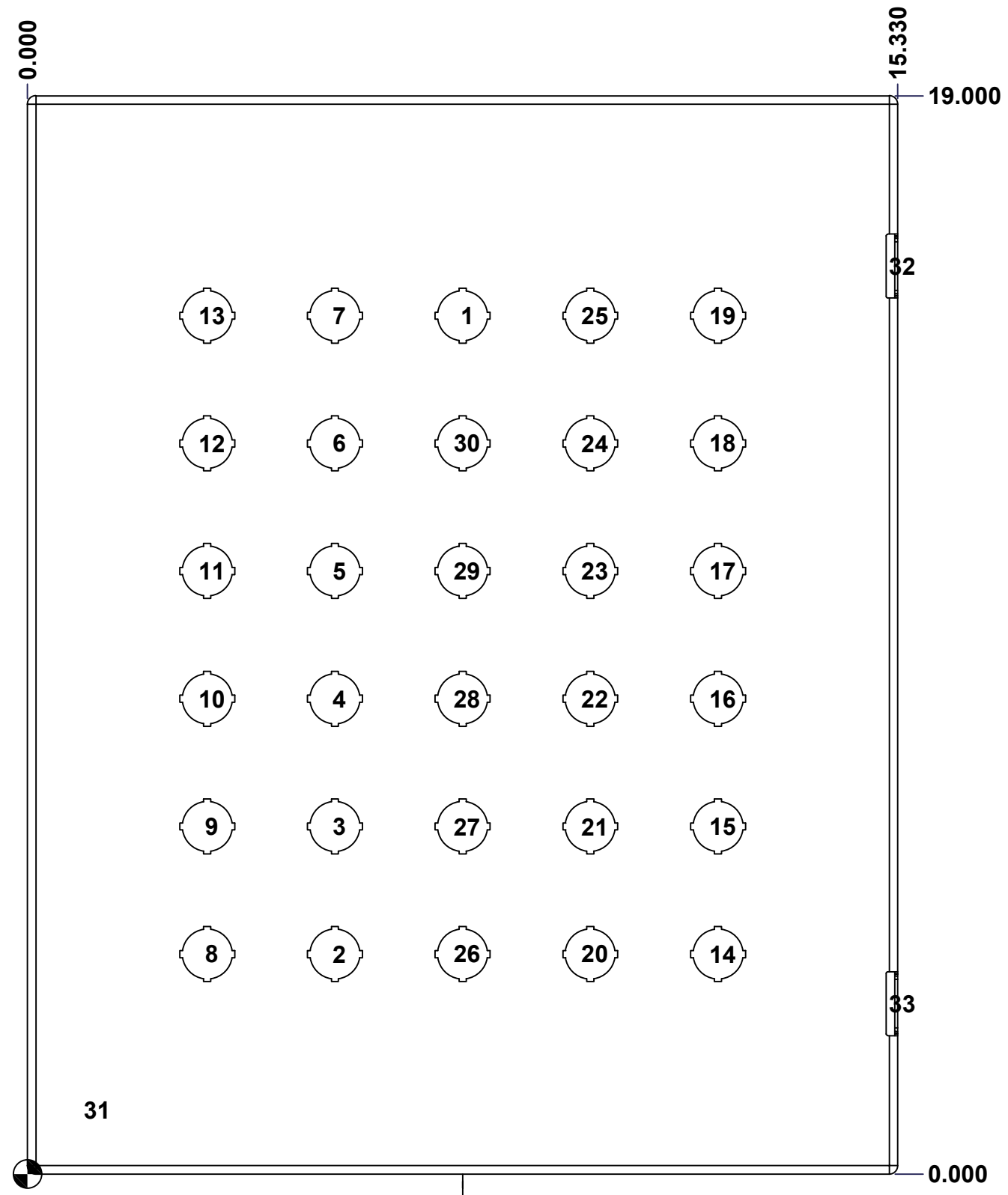

FRONT

	Description 1412EL 19" x 15.25" Cover	Status (NULL)
	Part Number Numéro Pièce 1412EL181506MNC	Rev. 8 0

This drawing is confidential and must not be reproduced or used without the consent of EXM

Ce dessin est confidentiel et ne doit pas être reproduit ou utilisé sans le consentement de EXM

No.	Revisions	Date	By/Par

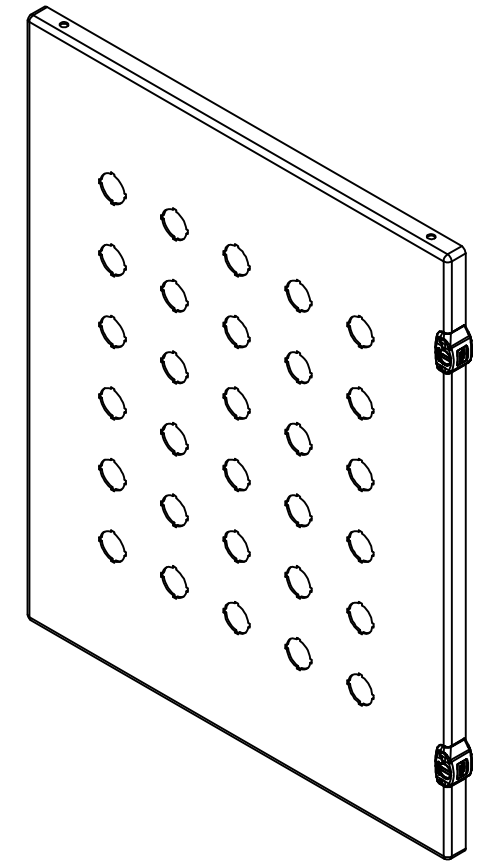

Isometric View

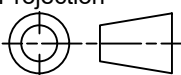

 Tél: (450) 979-4373 Fax: (450) 979-4626 www.exmweb.com	Flatness Aplatissement	Max 3.0mm
	Projection	
Customer Client	Date	
Drawn By Dessiné Par	BoxCad: BoxCad	Date 11-Jul-25
Material Matière	16 Ga Cold Rolled A1008 CS Type B (1.4mm)	
Color Couleur	Asa-61 Grey	Finish Fini Smooth
Description	Detail Rev.	
1412ELMN 19" x 15.25" Cover		
Part Number Numéro Pièce	Rev.	9
1412EL181506MNC	0	11

Qty	Part Number	Rev	Description
1	1412EL181506MNG	0	1412EL 19" x 15.25" Gasket
1	STK-Q-08350	5	Standoff M6 x 10mm
1	STK-P-02400S	0	Powder Paint (Asa-61 Grey / Smooth)
1	1412EL181506MNC-P	0	1412EL 19" x 15.25" Cover Part
2	STK-A-33033	4	5412 ESMCH Hinge
2	STK-A-79960	14	5412 ESMCH - External Lock Assy - Slot Lock
Parts List			

This drawing is confidential and must not be reproduced or used without the consent of EXM

Ce dessin est confidentiel et ne doit pas être reproduit ou utilisé sans le consentement de EXM

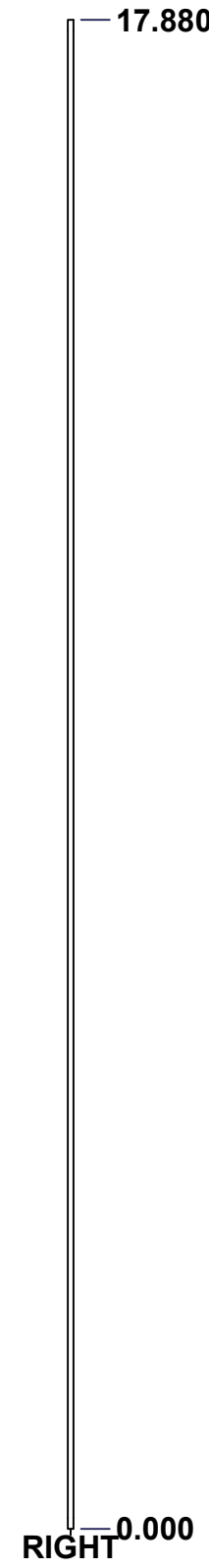
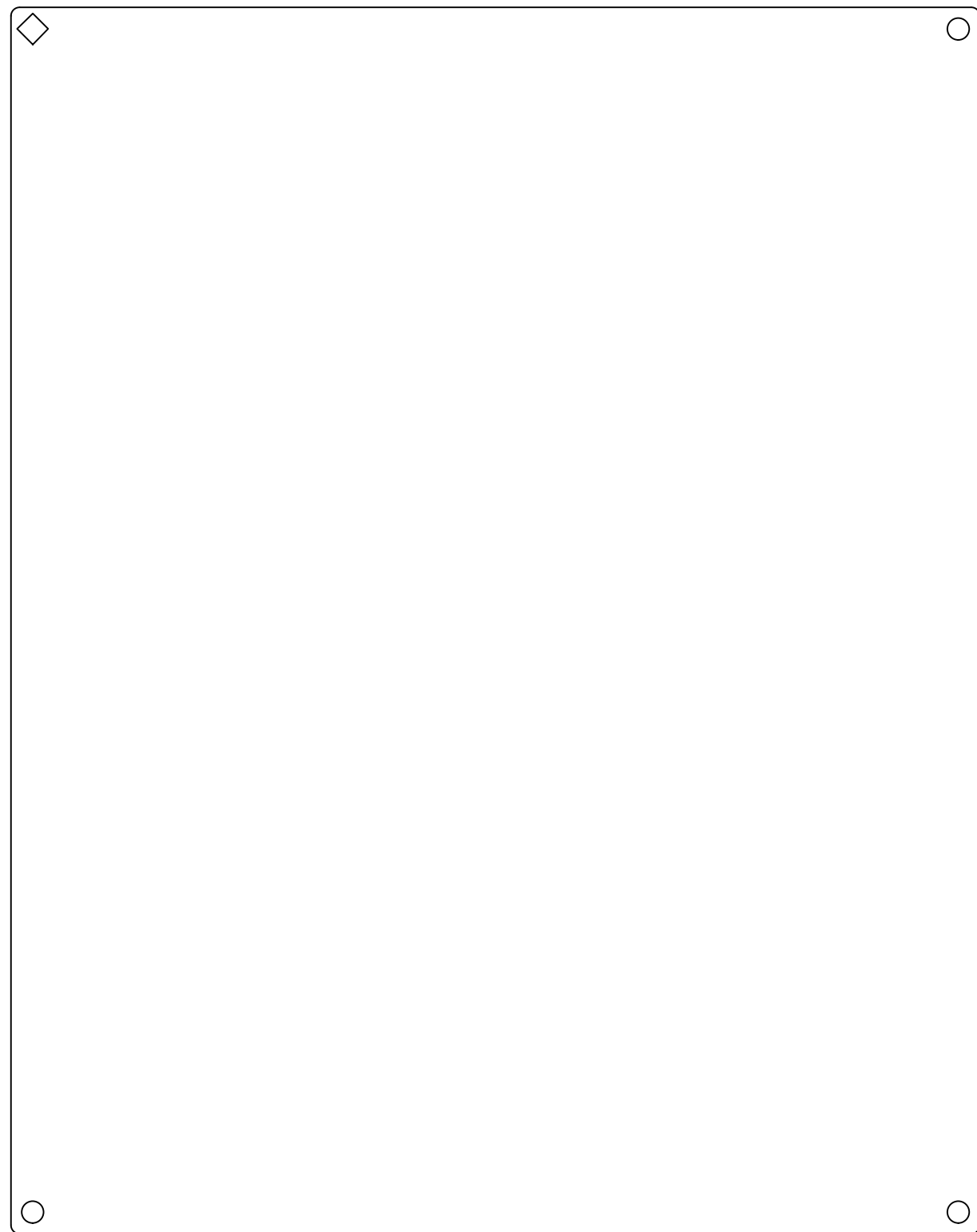
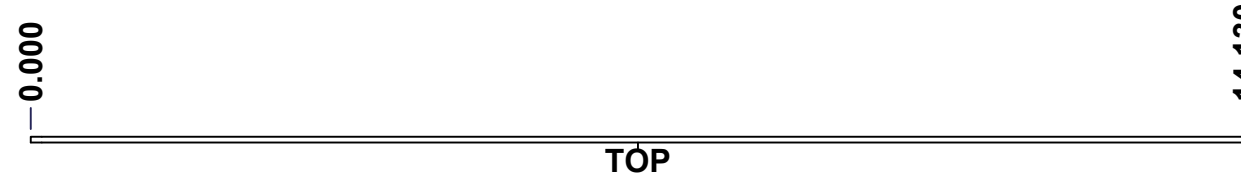

No.	Revisions	Date	By/Par

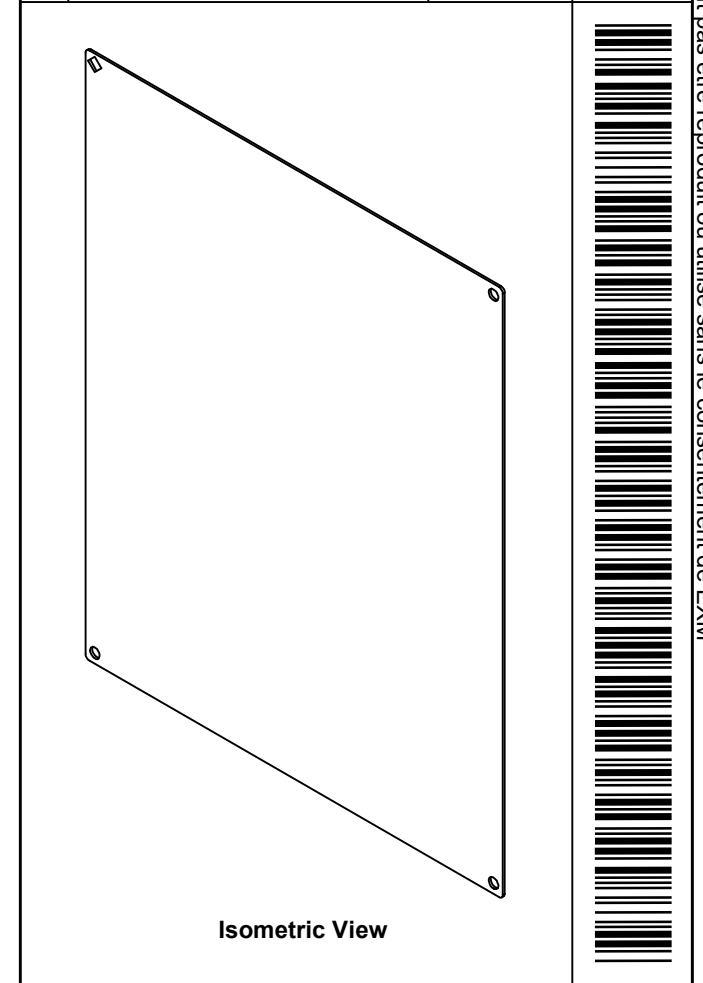

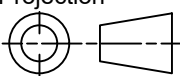
 Tél: (450) 979-4373 Fax: (450) 979-4626 www.exmweb.com		Flatness Aplatissement Max 3.0mm Projection 
Customer Client	Date	
Drawn By Dessiné Par	BoxCad: BoxCad	Date 11-Jul-25
Material Matière	14 Ga Galvanized (1.7mm)	
Color Couleur	Unpainted	Finish Fini Unpainted
Description	Detail Rev.	
1412EL 19" x 15.25" Inner Panel		
Part Number Numéro Pièce	Rev.	10
1412EL181506MNIP	0	11

SEE BILL OF MATERIAL ON LAST PAGE

This drawing is confidential and must not be reproduced or used without the consent of EXM

Ce dessin est confidentiel et ne doit pas être reproduit ou utilisé sans le consentement de EXM

No.	Revisions	Date	By/Par

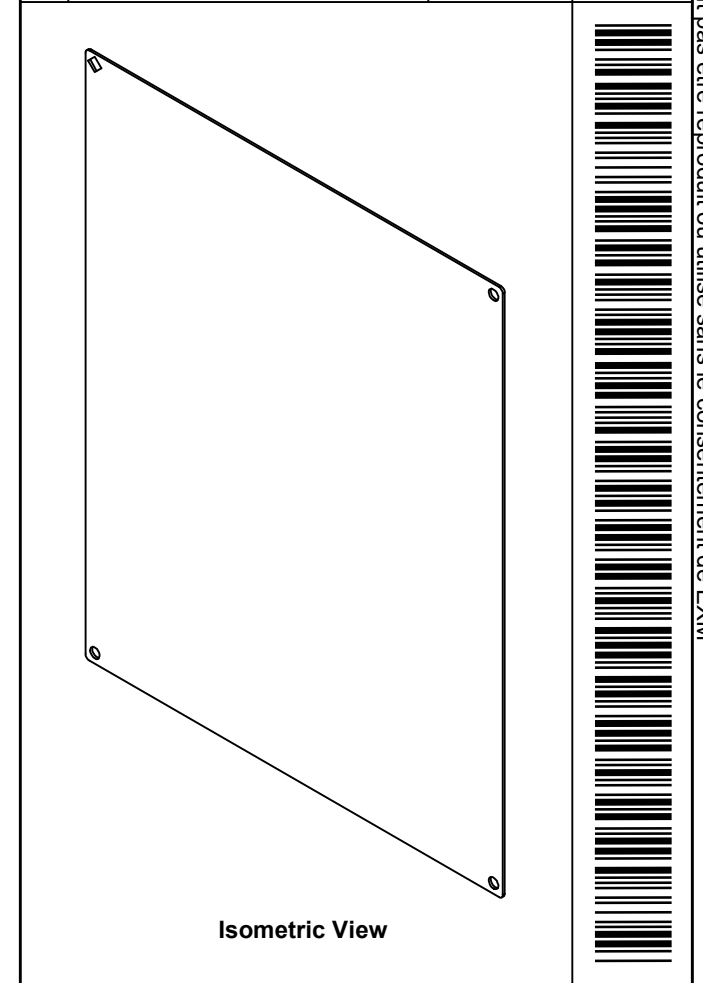

 Tél: (450) 979-4373 Fax: (450) 979-4626 www.exmweb.com		Flatness Aplatissement Max 3.0mm
Customer Client		Date
Drawn By / Dessiné Par: BoxCad: BoxCad		Date: 11-Jul-25
Material / Matière: 14 Ga Galvanized (1.7mm)		
Color / Couleur: Unpainted	Finish / Fini: Unpainted	
Description: 1412EL 19" x 15.25" Inner Panel		Detail Rev.
Part Number / Numéro Pièce: 1412EL181506MNIP		Rev. 0 / 11

Qty	Part Number	Rev	Description
1	1412EL181506MNIP-P	0	1412EL 19" x 15.25" Inner Panel Part
Parts List			