

This drawing is confidential and must not be reproduced or used without the consent of EXM

Ce dessin est confidentiel et ne doit pas être reproduit ou utilisé sans le consentement de EXM

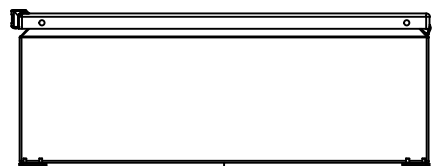

TOP

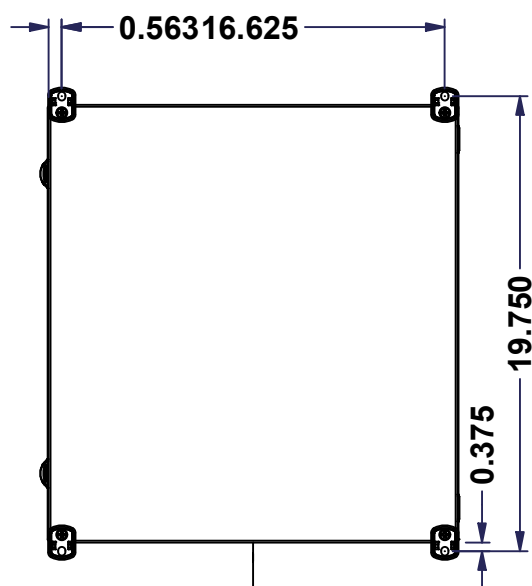

BACK

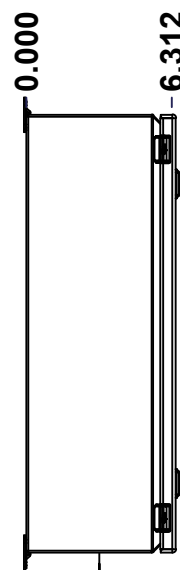

LEFT

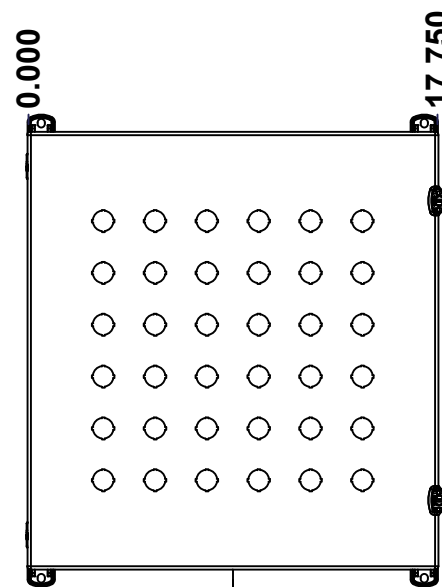

FRONT

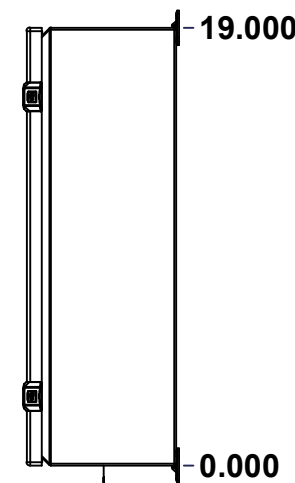

RIGHT

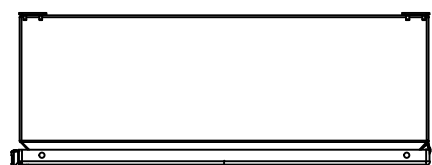

BOTTOM

No.	Revisions	Date	By/Par

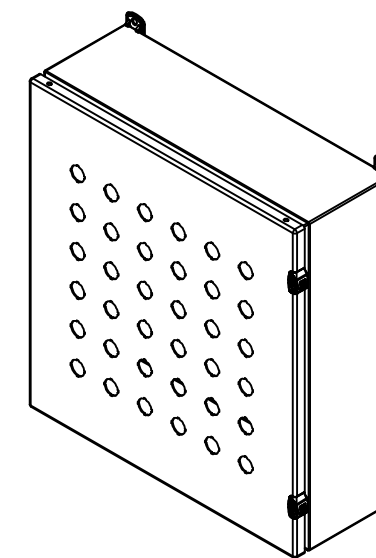

Isometric View



Tél: (450) 979-4373
 Fax: (450) 979-4626
www.exmweb.com

Flatness
Aplatissement

Max 3.0mm

Projection



Customer Client	Date
Drawn By Dessiné Par BoxCad: BoxCad	Date 11-Jul-25
Material Matière 16 Ga Cold Rolled A1008 CS Type B (1.4mm)	
Color Couleur Asa-61 Grey	Finish Fini Smooth
Description 1412ELMN 19" x 17.75" x 6" Assembly	Detail Rev.
Part Number Numéro Pièce 1412EL181706MN	Rev. 0

SEE BILL OF MATERIAL ON LAST PAGE

This drawing is confidential and must not be reproduced or used without the consent of EXM

Ce dessin est confidentiel et ne doit pas être reproduit ou utilisé sans le consentement de EXM

NOTE	
ITEM	DESCRIPTION
1	NEMA 4, 12 Enclosure (IP66)
2	C/W Standard ground standoffs on box and cover
3	W/O Standard door stiffener
4	C/W Special inner panel (Sold separately)
5	C/W Standard inner panel mounting standoffs
6	C/W 885 ESCHMF1 Mounting Feet (Installed)

No.	Revisions	Date	By/Par

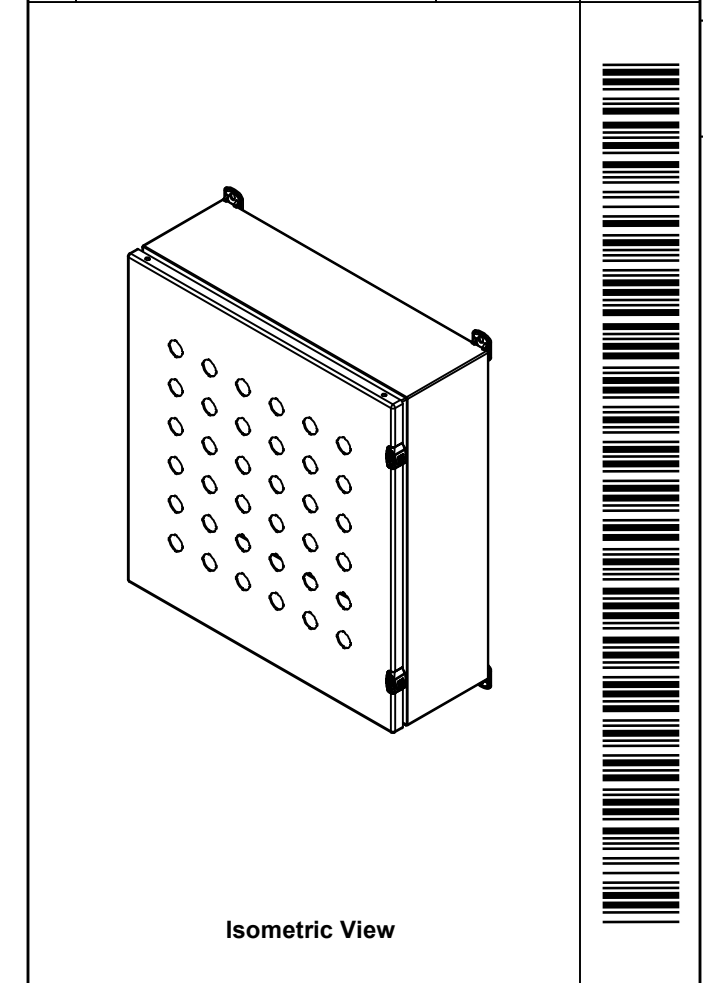

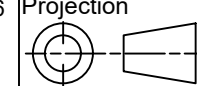
 Tél: (450) 979-4373 Fax: (450) 979-4626 www.exmweb.com	Flatness Aplatissement Max 3.0mm
	Projection 
Customer Client	Date
Drawn By Dessiné Par BoxCad: BoxCad	Date 11-Jul-25
Material Matière 16 Ga Cold Rolled A1008 CS Type B (1.4mm)	
Color Couleur Asa-61 Grey	Finish Fini Smooth
Description 1412ELMN 19" x 17.75" x 6" Assembly	
Part Number Numéro Pièce 1412EL181706MN	Rev. 2 0 11

PACKING		
ITEM	QTY	DESCRIPTION
Cardboard sleeve	2	Top and Bottom
Cardboard strip	2	Between back of enclosure and inner panel
Plastic bag	1	To protect cover surface and inside gasket
Plastic strap - Black	2	To Squeeze the 2 cardboard sleeve together
Packaging label	1	White label with product number

Qty	Part Number	Rev	Description
1	1412EL181706MNC	0	1412ELMN 19" x 17.75" Cover
1	1412EL181706MNIP	0	1412EL 19" x 17.75" Inner Panel
1	STK-K-02910	3	5412 ESCH Accessory Kit
1	1412EL181706MNB	0	1412ELMN 19" x 17.75" x 6" Body
Parts List			

This drawing is confidential and must not be reproduced or used without the consent of EXM

Ce dessin est confidentiel et ne doit pas être reproduit ou utilisé sans le consentement de EXM

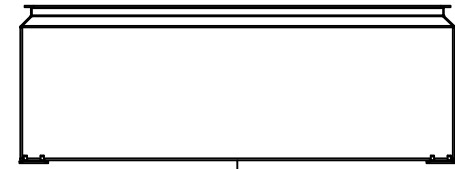

TOP

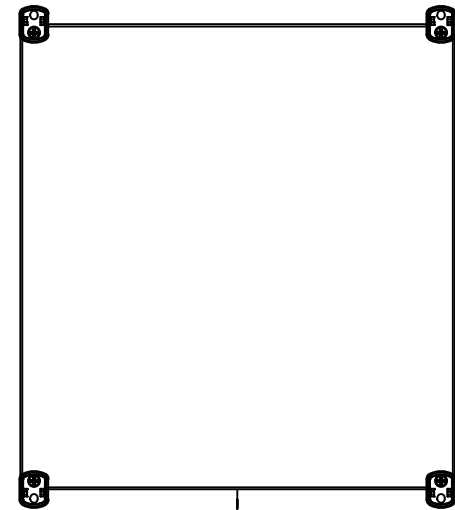

BACK



BOTTOM

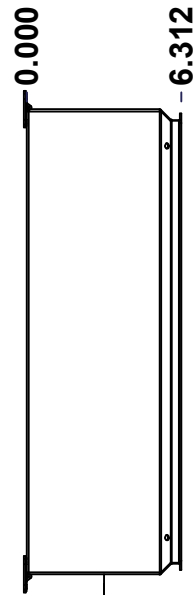

LEFT

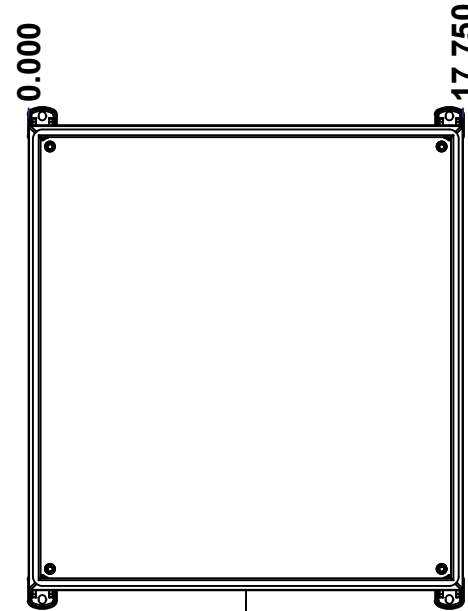

FRONT

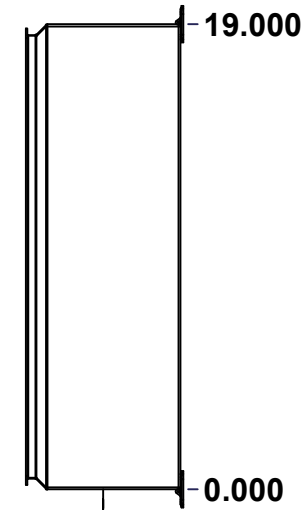

RIGHT

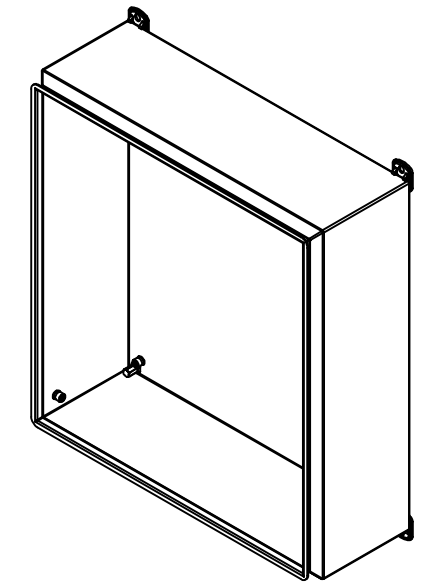

Isometric View

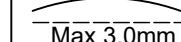
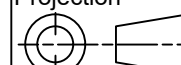

No.	Revisions	Date	By/Par

 Tél: (450) 979-4373 Fax: (450) 979-4626 www.exmweb.com		Flatness Aplatissement  Max 3.0mm Projection 
Customer Client	Date	
Drawn By / Dessiné Par: BoxCad: BoxCad	Date: 11-Jul-25	
Material / Matière: 16 Ga Cold Rolled A1008 CS Type B (1.4mm)		
Color / Couleur: Asa-61 Grey	Finish / Fini: Smooth	
Description: 1412ELMN 19" x 17.75" x 6" Body	Detail Rev.	
Part Number / Numéro Pièce: 1412EL181706MNB	Rev. 0	3 / 11

SEE BILL OF MATERIAL ON LAST PAGE

This drawing is confidential and must not be reproduced or used without the consent of EXM

Ce dessin est confidentiel et ne doit pas être reproduit ou utilisé sans le consentement de EXM

STANDARD FEATURES ARE NOT LISTED IN THIS HOLE TABLE			
HOLE TABLE - LEFT VIEW (CUSTOM FEATURE ONLY)			
CUT-OUT	XDIM	YDIM	DESCRIPTION
1	4.625	0.875	STANDOFF M6 x 10mm (Inside)

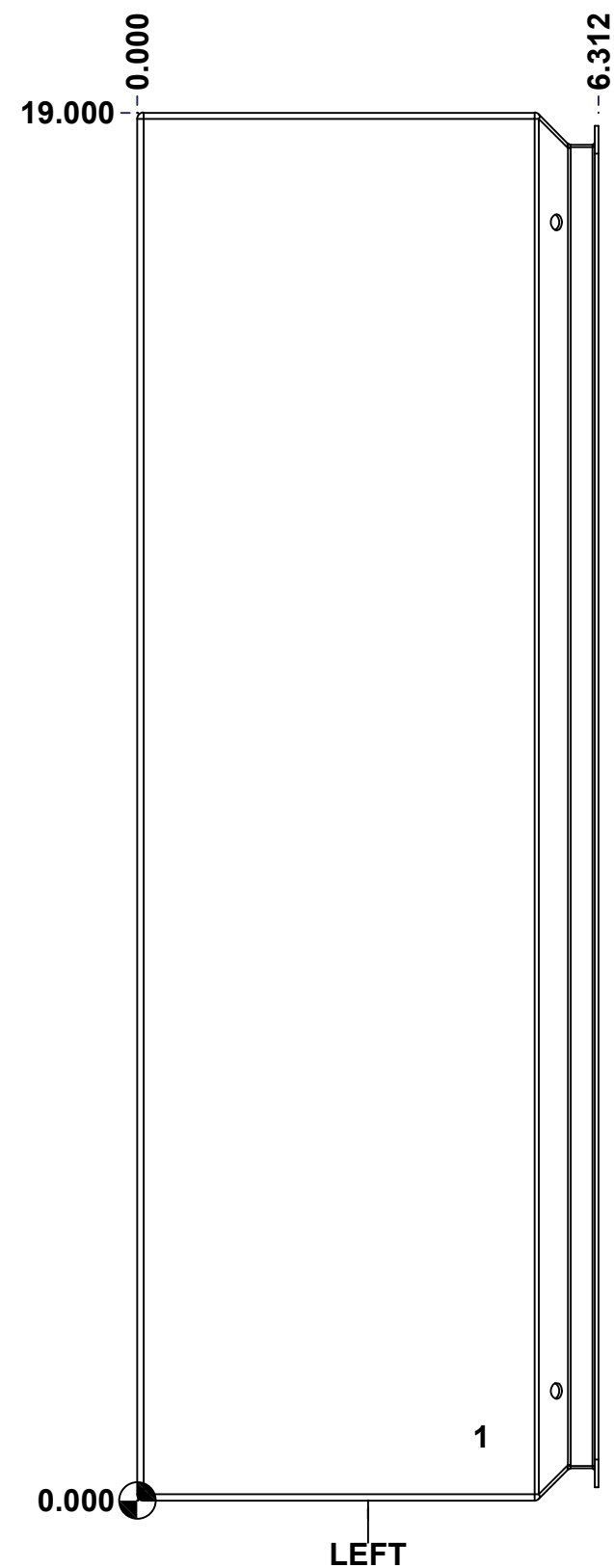

	Description	Status	
	1412EL 19" x 17.75" x 6" Body	(NULL)	
	Part Number Numéro Pièce	Rev.	4
	1412EL181706MNB	0	11

This drawing is confidential and must not be reproduced or used without the consent of EXM

Ce dessin est confidentiel et ne doit pas être reproduit ou utilisé sans le consentement de EXM

STANDARD FEATURES ARE NOT LISTED IN THIS HOLE TABLE

HOLE TABLE - BACK VIEW (CUSTOM FEATURE ONLY)

CUT-OUT	XDIM	YDIM	DESCRIPTION
1	0.875	0.875	IP STANDOFF M6 x 10mm (Inside)
2	0.875	18.125	IP STANDOFF M6 x 10mm (Inside)
3	16.875	18.125	IP STANDOFF M6 x 10mm (Inside)
4	16.875	0.875	IP STANDOFF M6 x 10mm (Inside)

5	17.187	0.000	FOOT 885 ESCHMF1
6	0.563	0.000	FOOT 885 ESCHMF1
7	17.187	19.000	FOOT 885 ESCHMF1
8	0.563	19.000	FOOT 885 ESCHMF1
9	17.187	0.344	RIVET NUT M6_FH_CE (Inside)
10	0.563	0.344	RIVET NUT M6_FH_CE (Inside)
11	17.187	18.656	RIVET NUT M6_FH_CE (Inside)
12	0.563	18.656	RIVET NUT M6_FH_CE (Inside)

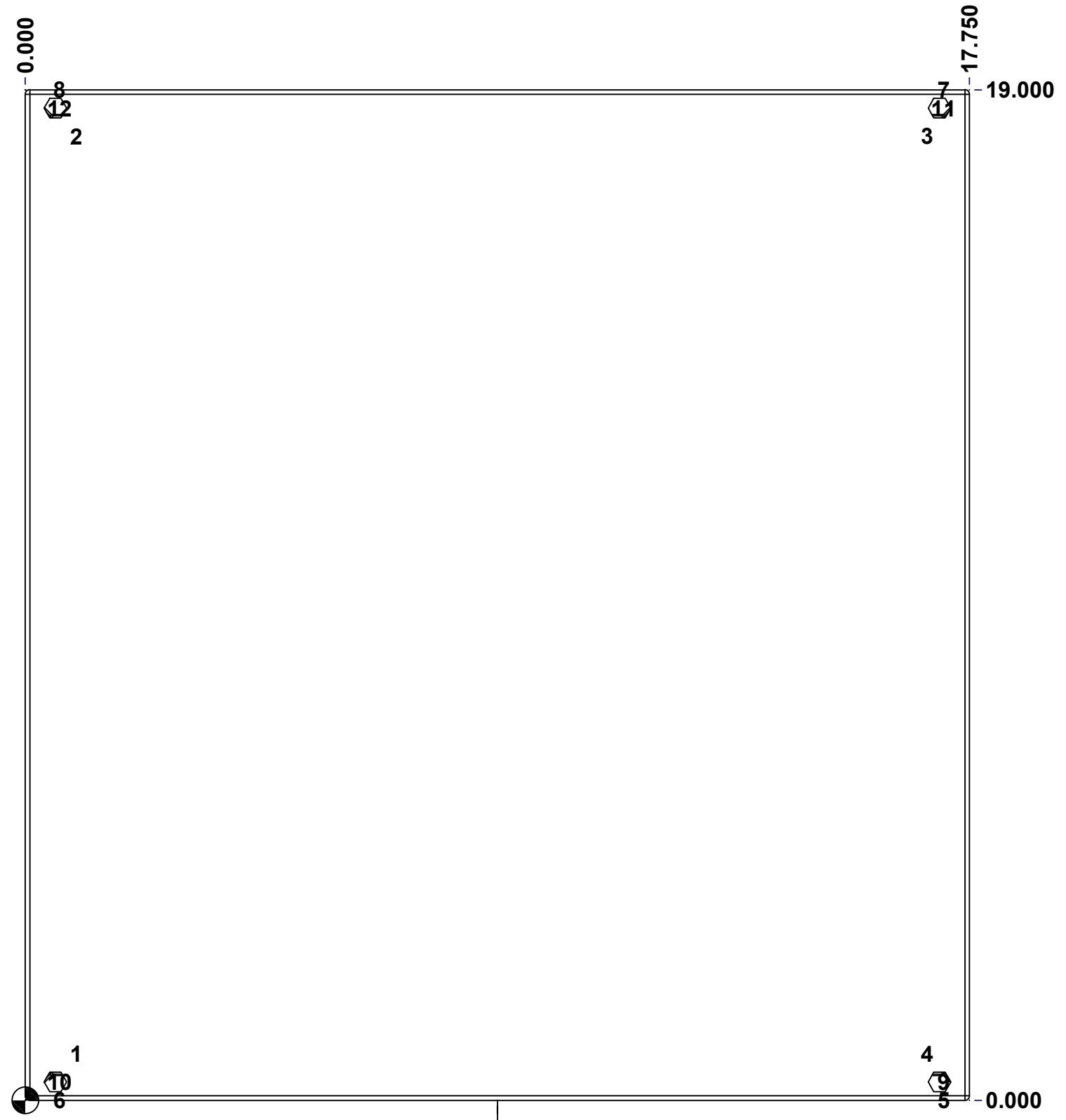

BACK

	Description	Status
	1412EL 19" x 17.75" x 6" Body	(NULL)
	Part Number Numéro Pièce	Rev.
	1412EL181706MNB	0 / 5
		11

This drawing is confidential and must not be reproduced or used without the consent of EXM

Ce dessin est confidentiel et ne doit pas être reproduit ou utilisé sans le consentement de EXM

No.	Revisions	Date	By/Par

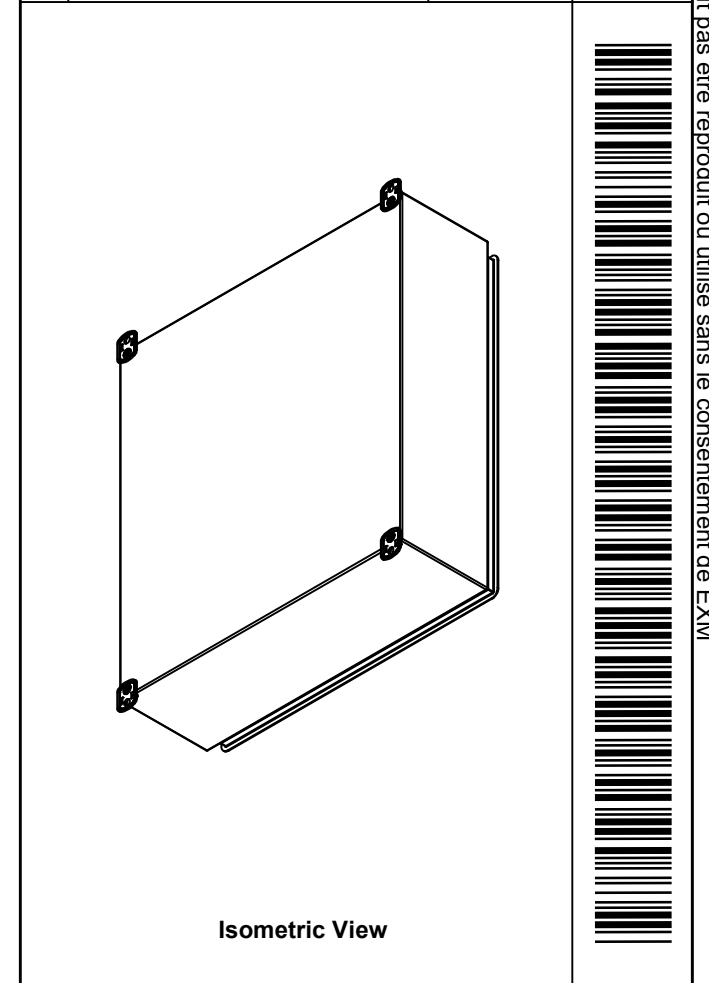

Tél: (450) 979-4373 Fax: (450) 979-4626 www.exmweb.com		Flatness Aplatissement	
		Max 3.0mm	
Customer Client		Date	
Drawn By Dessiné Par BoxCad: BoxCad		Date 11-Jul-25	
Material Matière 16 Ga Cold Rolled A1008 CS Type B (1.4mm)			
Color Couleur Asa-61 Grey		Finish Fini Smooth	
Description 1412ELMN 19" x 17.75" x 6" Body			Detail Rev.
Part Number Numéro Pièce 1412EL181706MNB			Rev. 6 0

4	RIVET_NUT_M6_FH_CE	0	Rivet Nut M6 (Low Profile Close End)
4	STK-Q-03071	0	M6 x 16mm Machine Screw
1	STK-P-02400S	0	Powder Paint (Asa-61 Grey / Smooth)
1	1412EL181706MNB-P	0	1412EL 19" x 17.75" x 6" Body Part
4	885 ESCHMF1	2	5412 ESCH Stamped Mounting Foot
5	STK-Q-08350	5	Standoff M6 x 10mm
Qty	Part Number	Rev	Description
Parts List			

This drawing is confidential and must not be reproduced or used without the consent of EXM

Ce dessin est confidentiel et ne doit pas être reproduit ou utilisé sans le consentement de EXM

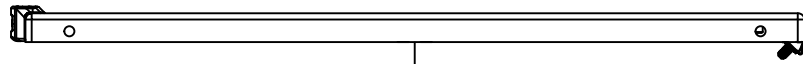

TOP

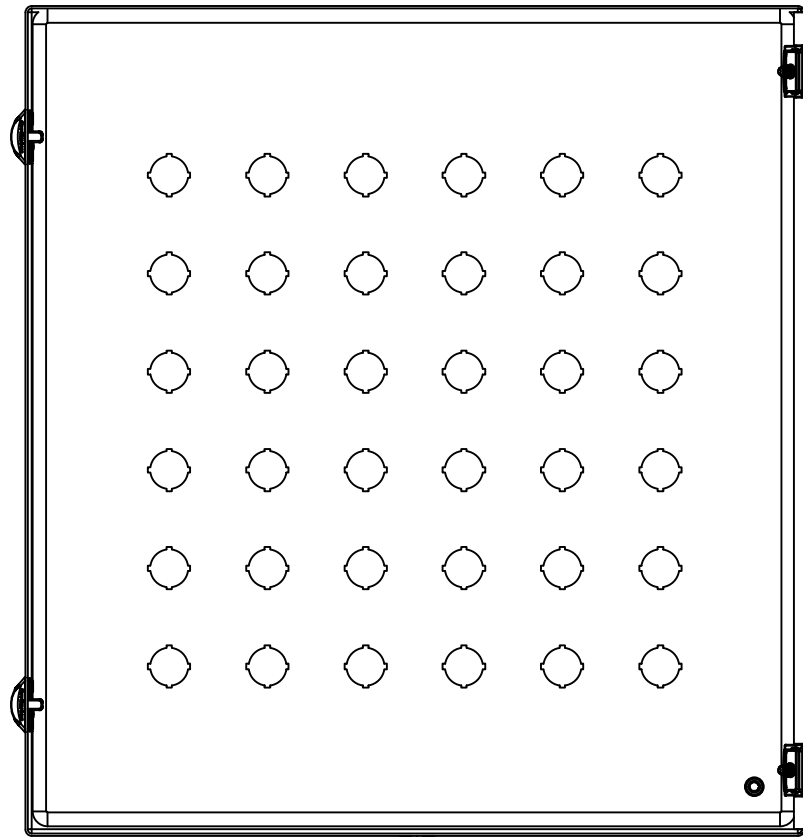

BACK

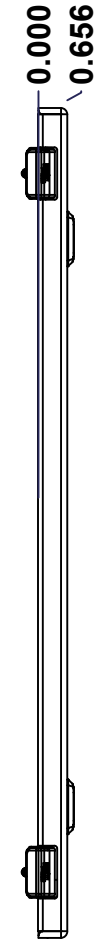

LEFT

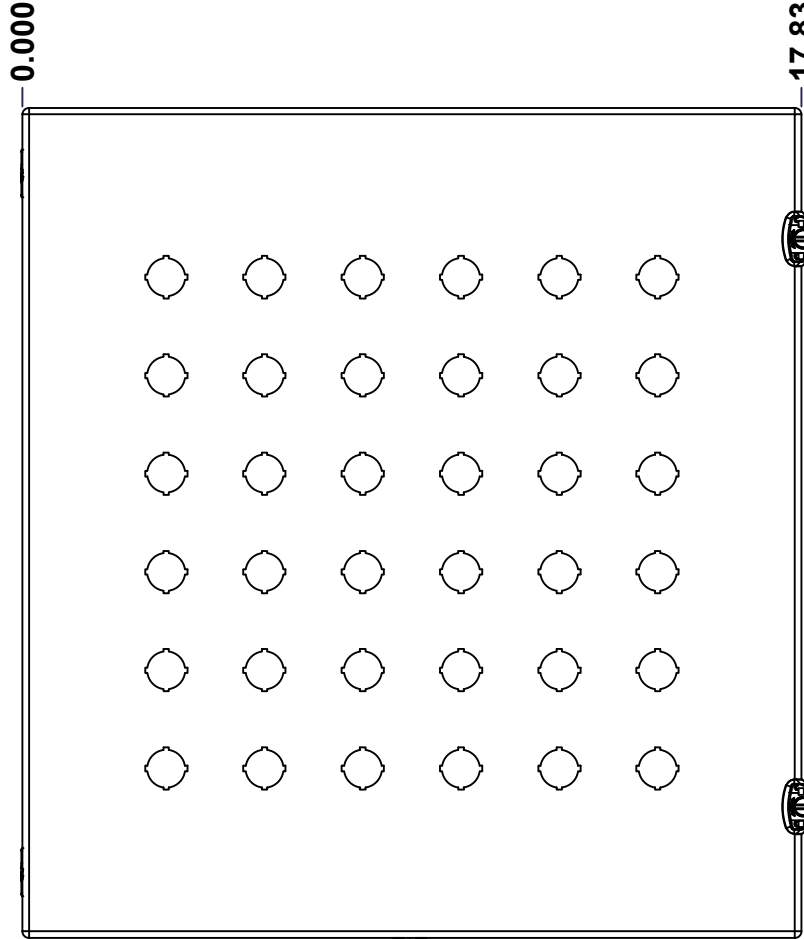

FRONT

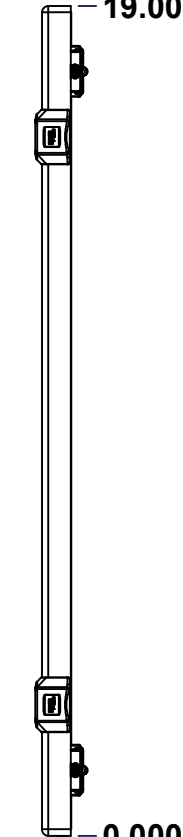

RIGHT

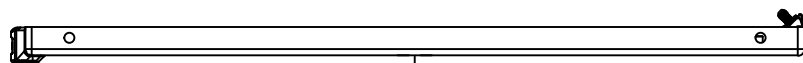

BOTTOM

No.	Revisions	Date	By/Par

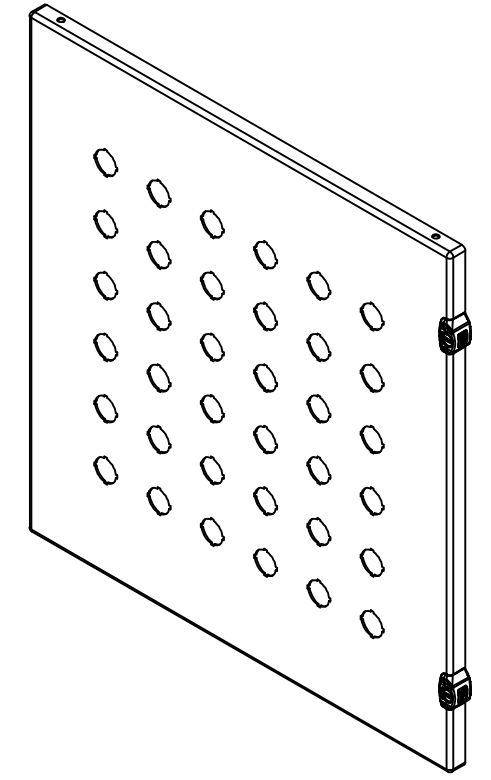

Isometric View

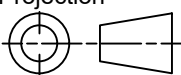

 Tél: (450) 979-4373 Fax: (450) 979-4626 www.exmweb.com		Flatness Aplatissement Max 3.0mm Projection 
Customer Client	Date	
Drawn By Dessiné Par	BoxCad: BoxCad	Date 11-Jul-25
Material Matière	16 Ga Cold Rolled A1008 CS Type B (1.4mm)	
Color Couleur	Asa-61 Grey	Finish Fini Smooth
Description		Detail Rev.
1412ELMN 19" x 17.75" Cover		
Part Number Numéro Pièce	Rev.	7
1412EL181706MNC	0	11

SEE BILL OF MATERIAL ON LAST PAGE

This drawing is confidential and must not be reproduced or used without the consent of EXM

Ce dessin est confidentiel et ne doit pas être reproduit ou utilisé sans le consentement de EXM

STANDARD FEATURES ARE NOT LISTED IN THIS HOLE TABLE			
HOLE TABLE - FRONT VIEW (CUSTOM FEATURE ONLY)			
CUT-OUT	XDIM	YDIM	DESCRIPTION
1	10.040	3.875	22.5 mm Miniature Pushbutton
2	10.040	6.125	22.5 mm Miniature Pushbutton
3	10.040	8.375	22.5 mm Miniature Pushbutton
4	10.040	10.625	22.5 mm Miniature Pushbutton
5	10.040	12.875	22.5 mm Miniature Pushbutton
6	10.040	15.125	22.5 mm Miniature Pushbutton
7	7.790	3.875	22.5 mm Miniature Pushbutton
8	7.790	6.125	22.5 mm Miniature Pushbutton
9	7.790	8.375	22.5 mm Miniature Pushbutton
10	7.790	10.625	22.5 mm Miniature Pushbutton
11	7.790	12.875	22.5 mm Miniature Pushbutton
12	7.790	15.125	22.5 mm Miniature Pushbutton
13	5.540	3.875	22.5 mm Miniature Pushbutton
14	5.540	6.125	22.5 mm Miniature Pushbutton
15	5.540	8.375	22.5 mm Miniature Pushbutton
16	5.540	10.625	22.5 mm Miniature Pushbutton
17	5.540	12.875	22.5 mm Miniature Pushbutton
18	5.540	15.125	22.5 mm Miniature Pushbutton
19	3.290	3.875	22.5 mm Miniature Pushbutton
20	3.290	6.125	22.5 mm Miniature Pushbutton
21	3.290	8.375	22.5 mm Miniature Pushbutton
22	3.290	10.625	22.5 mm Miniature Pushbutton
23	3.290	12.875	22.5 mm Miniature Pushbutton
24	3.290	15.125	22.5 mm Miniature Pushbutton
25	14.540	3.875	22.5 mm Miniature Pushbutton
26	14.540	6.125	22.5 mm Miniature Pushbutton
27	14.540	8.375	22.5 mm Miniature Pushbutton
28	14.540	10.625	22.5 mm Miniature Pushbutton
29	14.540	12.875	22.5 mm Miniature Pushbutton
30	14.540	15.125	22.5 mm Miniature Pushbutton
31	12.290	3.875	22.5 mm Miniature Pushbutton
32	12.290	6.125	22.5 mm Miniature Pushbutton
33	12.290	8.375	22.5 mm Miniature Pushbutton
34	12.290	10.625	22.5 mm Miniature Pushbutton
35	12.290	12.875	22.5 mm Miniature Pushbutton
36	12.290	15.125	22.5 mm Miniature Pushbutton
37	1.145	1.125	STANDOFF M6 x 10mm (Inside)
38	17.830	16.000	LOCK 880 SCQ2MS @ 0.0°
39	17.830	3.000	LOCK 880 SCQ2MS @ 0.0°

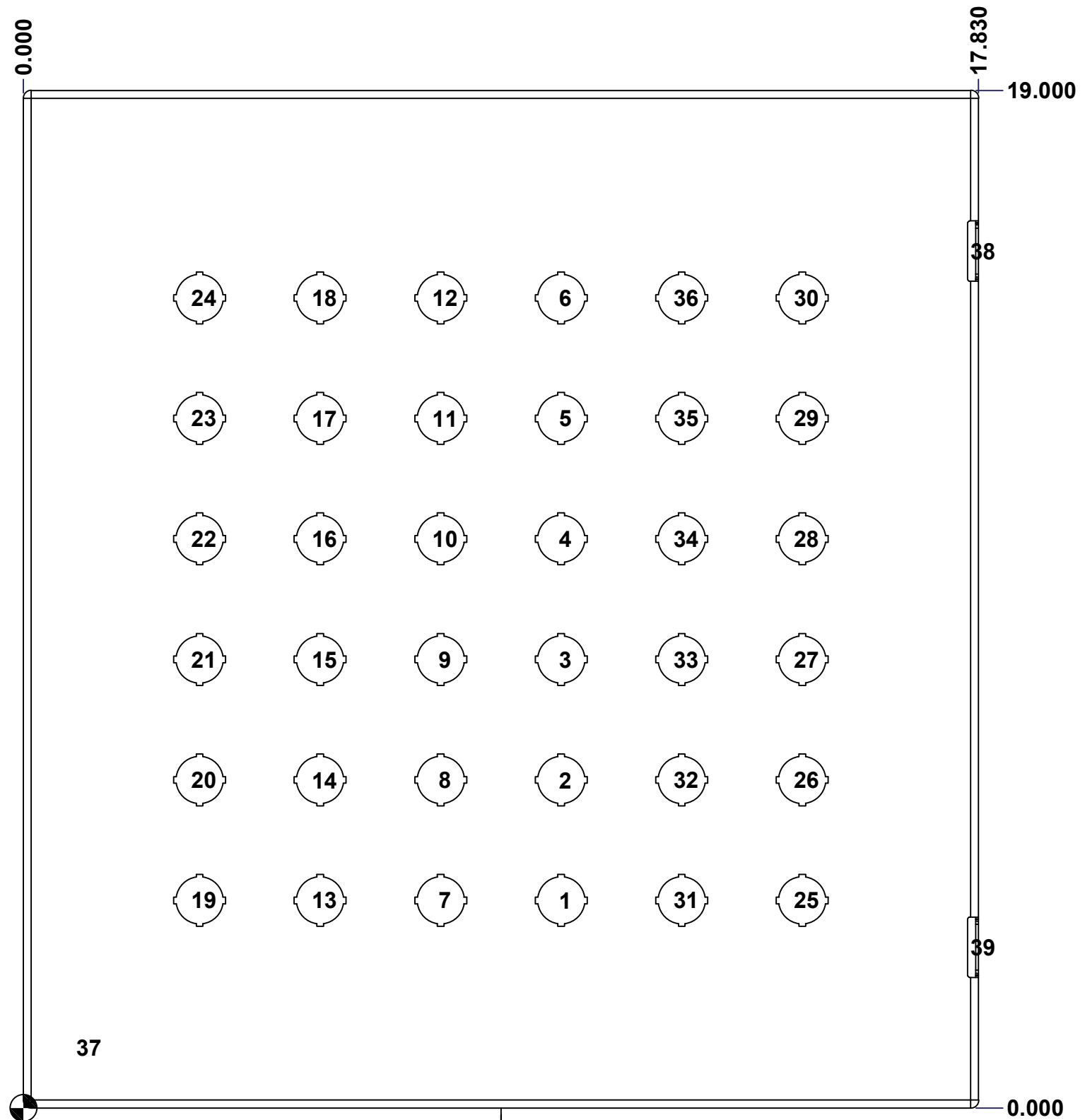

FRONT

	Description 1412EL 19" x 17.75" Cover	Status (NULL)
	Part Number Numéro Pièce 1412EL181706MNC	Rev. 8 0

This drawing is confidential and must not be reproduced or used without the consent of EXM

Ce dessin est confidentiel et ne doit pas être reproduit ou utilisé sans le consentement de EXM

No.	Revisions	Date	By/Par

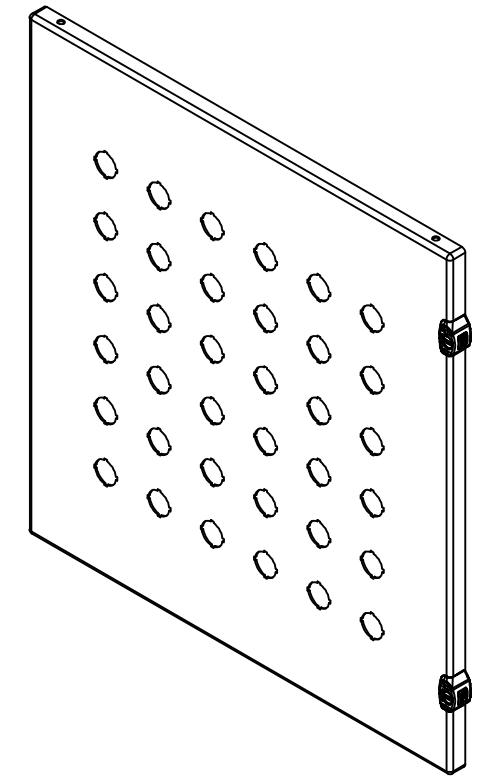

Isometric View

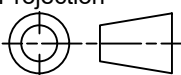

 Tél: (450) 979-4373 Fax: (450) 979-4626 www.exmweb.com	Flatness Aplatissement	Max 3.0mm
	Projection	
Customer Client	Date	
Drawn By Dessiné Par	BoxCad: BoxCad	Date 11-Jul-25
Material Matière	16 Ga Cold Rolled A1008 CS Type B (1.4mm)	
Color Couleur	Asa-61 Grey	Finish Fini Smooth
Description	1412ELMN 19" x 17.75" Cover	
Part Number Numéro Pièce	1412EL181706MNC	Rev. 9
		0

Qty	Part Number	Rev	Description
1	1412EL181706MNG	0	1412EL 19" x 17.75" Gasket
1	STK-Q-08350	5	Standoff M6 x 10mm
1	STK-P-02400S	0	Powder Paint (Asa-61 Grey / Smooth)
1	1412EL181706MNC-P	0	1412EL 19" x 17.75" Cover Part
2	STK-A-33033	4	5412 ESMCH Hinge
2	STK-A-79960	14	5412 ESMCH - External Lock Assy - Slot Lock
Parts List			

This drawing is confidential and must not be reproduced or used without the consent of EXM

Ce dessin est confidentiel et ne doit pas être reproduit ou utilisé sans le consentement de EXM

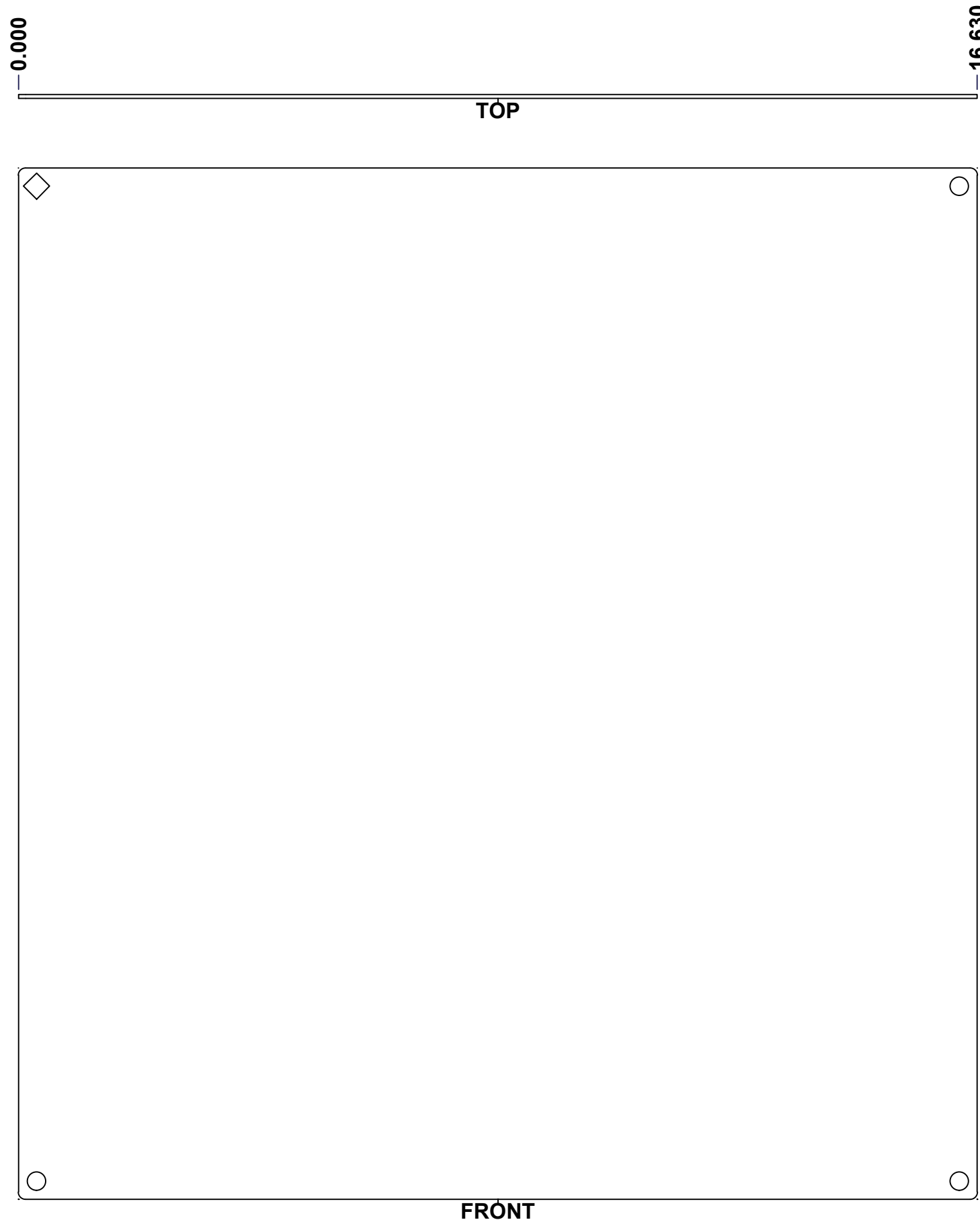

17.880

RIGHT 0.000

No.	Revisions	Date	By/Par

Isometric View

<p>Tél: (450) 979-4373 Fax: (450) 979-4626 www.exmweb.com</p>		Flatness Aplatissement
		Max 3.0mm
Customer Client Drawn By / Dessiné Par: BoxCad: BoxCad Material / Matière: 14 Ga Galvanized (1.7mm)		Projection
Date Date: 11-Jul-25		Finish / Fini: Unpainted
Description 1412EL 19" x 17.75" Inner Panel		Detail Rev.
Part Number / Numéro Pièce 1412EL181706MNIP		Rev. 10 0

SEE BILL OF MATERIAL ON LAST PAGE

This drawing is confidential and must not be reproduced or used without the consent of EXM

Ce dessin est confidentiel et ne doit pas être reproduit ou utilisé sans le consentement de EXM

No.	Revisions	Date	By/Par

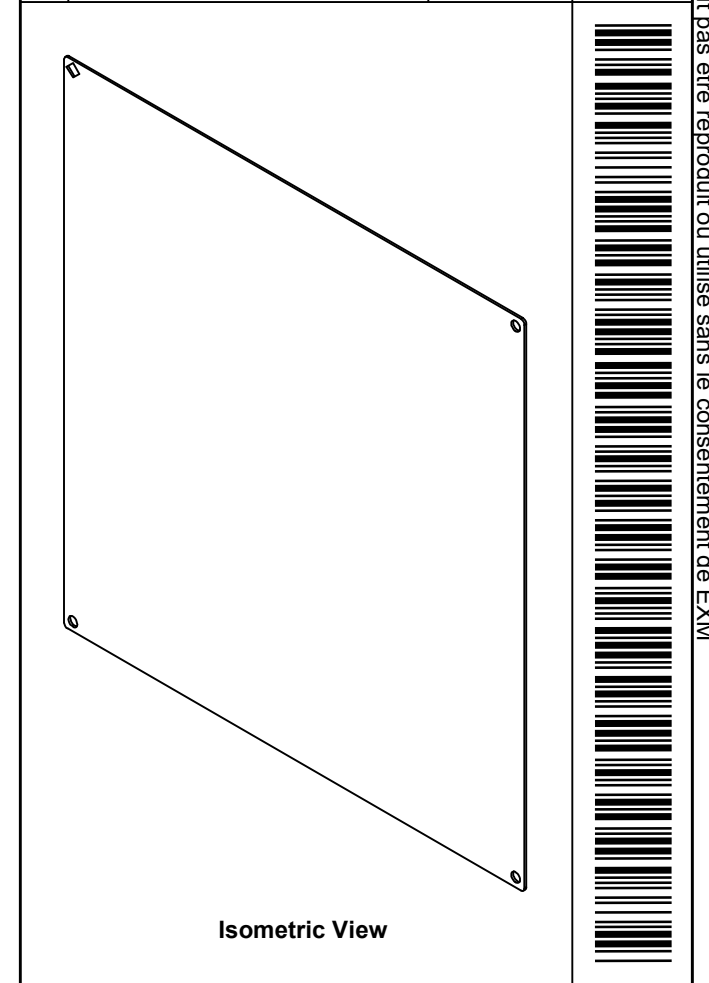

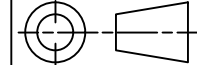
 Tél: (450) 979-4373 Fax: (450) 979-4626 www.exmweb.com		Flatness Aplatissement Max 3.0mm
Customer Client		Projection 
Drawn By / Dessiné Par: BoxCad: BoxCad		Date: 11-Jul-25
Material / Matière: 14 Ga Galvanized (1.7mm)		
Color / Couleur: Unpainted	Finish / Fini: Unpainted	
Description: 1412EL 19" x 17.75" Inner Panel		Detail Rev.
Part Number / Numéro Pièce: 1412EL181706MNIP		Rev. 0 / 11

Qty	Part Number	Rev	Description
1	1412EL181706MNIP-P	0	1412EL 19" x 17.75" Inner Panel Part
Parts List			