

This drawing is confidential and must not be reproduced or used without the consent of EXM

Ce dessin est confidentiel et ne doit pas être reproduit ou utilisé sans le consentement de EXM

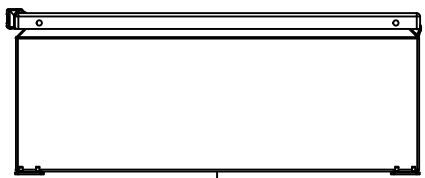

TOP

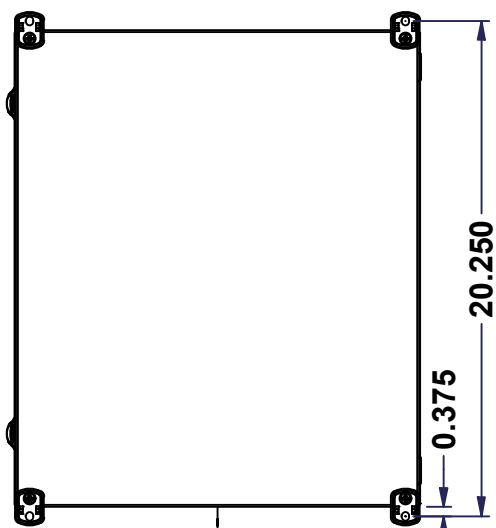

BACK

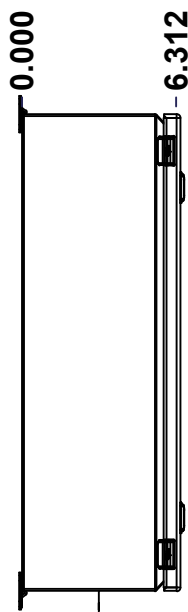

LEFT

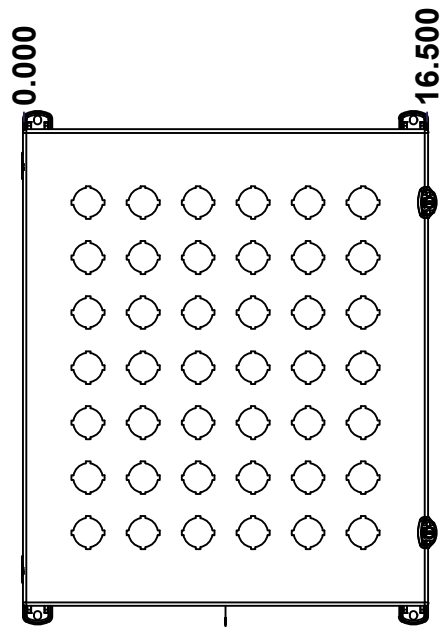

FRONT

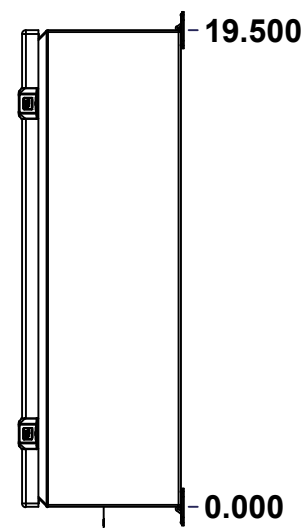

RIGHT

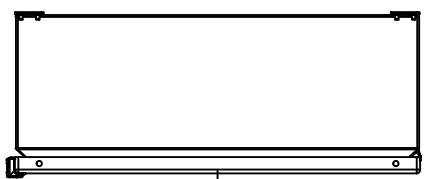

BOTTOM

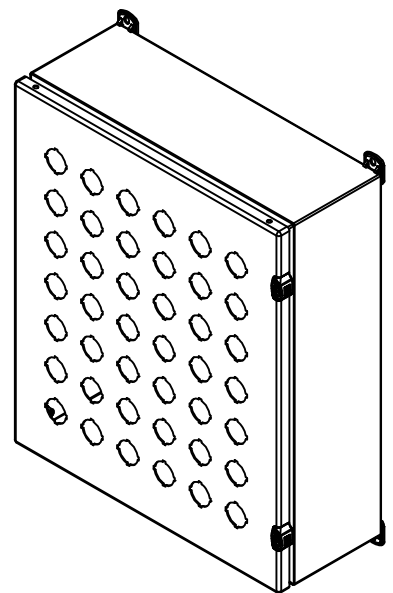

Isometric View

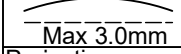
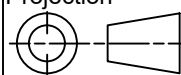

No.	Revisions	Date	By/Par

 Tél: (450) 979-4373 Fax: (450) 979-4626 <a href="http://www.exmweb.com">www.exmweb.com</a>		Flatness Aplatissement  Max 3.0mm Projection 
Customer Client		Date
Drawn By Dessiné Par	BoxCad: BoxCad	Date 11-Jul-25
Material Matière	16 Ga Cold Rolled A1008 CS Type B (1.4mm)	
Color Couleur	Asa-61 Grey	Finish Fini Smooth
Description 1412EL 19.5" x 16.5" x 6" Assembly		Detail Rev.
Part Number Numéro Pièce	1412EL191606	Rev. 1 0

SEE BILL OF MATERIAL ON LAST PAGE

This drawing is confidential and must not be reproduced or used without the consent of EXM

Ce dessin est confidentiel et ne doit pas être reproduit ou utilisé sans le consentement de EXM

NOTE	
ITEM	DESCRIPTION
1	NEMA 4, 12 Enclosure (IP66)
2	C/W Standard ground standoffs on box and cover
3	W/O Standard door stiffener
4	C/W Special inner panel (Sold separately)
5	C/W Standard inner panel mounting standoffs
6	C/W 885 ESCHMF1 Mounting Feet (Installed)

No.	Revisions	Date	By/Par

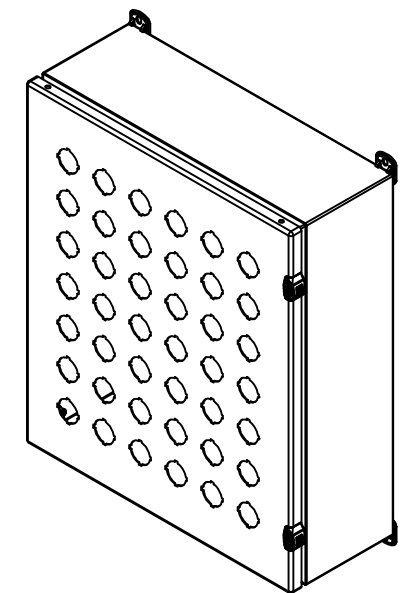

Isometric View



Tél: (450) 979-4373  
 Fax: (450) 979-4626  
[www.exmweb.com](http://www.exmweb.com)



Customer Client	Date
Drawn By / Dessiné Par: BoxCad: BoxCad	Date: 11-Jul-25
Material / Matière: 16 Ga Cold Rolled A1008 CS Type B (1.4mm)	

Color / Couleur: Asa-61 Grey	Finish / Fini: Smooth
------------------------------	-----------------------

Description: 1412EL 19.5" x 16.5" x 6" Assembly	Detail Rev.
---	-------------

Part Number / Numéro Pièce: <b>1412EL191606</b>	Rev. 0	2	11
---	--------	---	----

PACKING		
ITEM	QTY	DESCRIPTION
Cardboard sleeve	2	Top and Bottom
Cardboard strip	2	Between back of enclosure and inner panel
Plastic bag	1	To protect cover surface and inside gasket
Plastic strap - Black	2	To Squeeze the 2 cardboard sleeve together
Packaging label	1	White label with product number

Qty	Part Number	Rev	Description
1	1412EL191606C	0	1412EL 19.5" x 16.5" Cover
1	1412EL191606IP	0	1412EL 19.5" x 16.5" Inner Panel
1	STK-K-02910	3	5412 ESCH Accessory Kit
1	1412EL191606B	0	1412EL 19.5" x 16.5" x 6" Body

Parts List

This drawing is confidential and must not be reproduced or used without the consent of EXM

Ce dessin est confidentiel et ne doit pas être reproduit ou utilisé sans le consentement de EXM

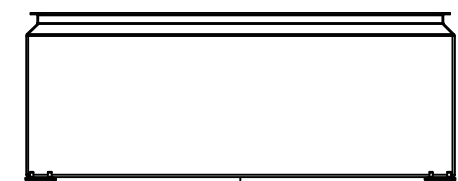

TOP

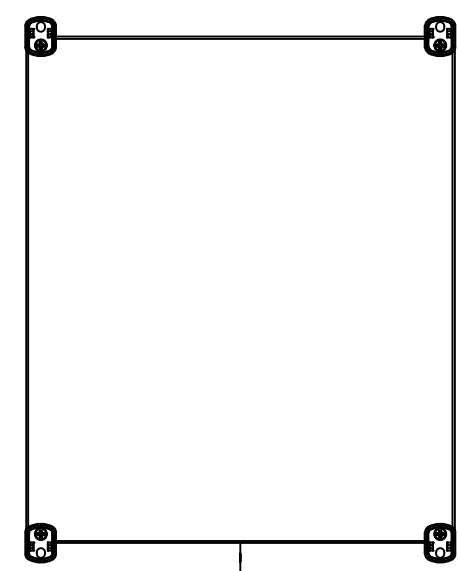

BACK



BOTTOM

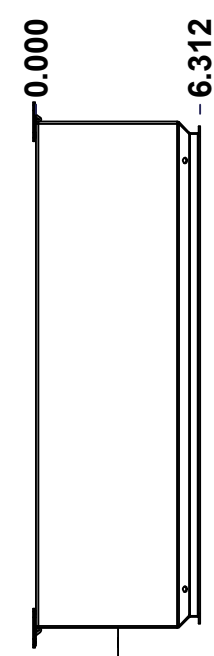

LEFT

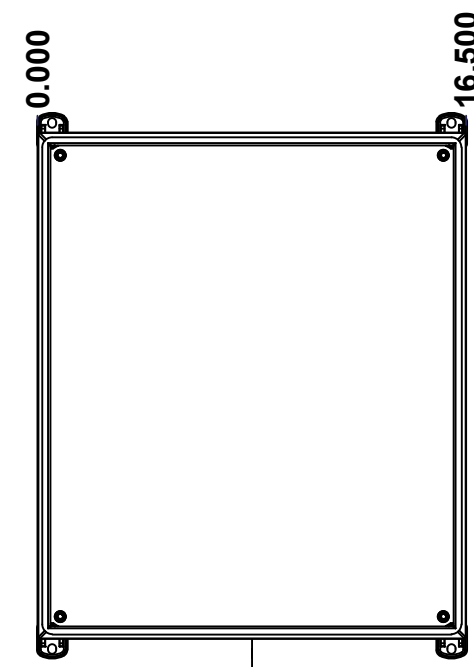

FRONT

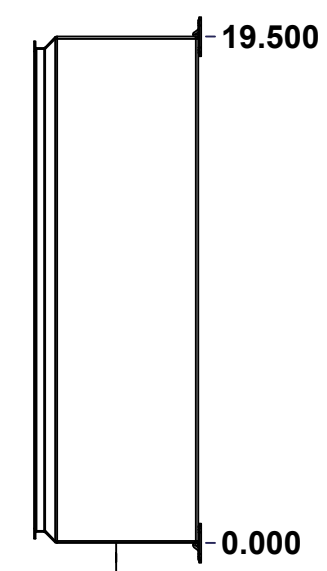

RIGHT

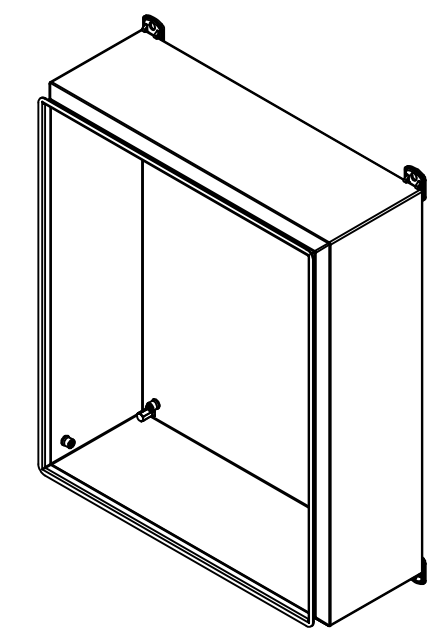

Isometric View

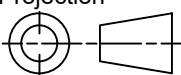

No.	Revisions	Date	By/Par

 Tél: (450) 979-4373 Fax: (450) 979-4626 <a href="http://www.exmweb.com">www.exmweb.com</a>		Flatness Aplatissement Max 3.0mm Projection 
Customer Client	Date	
Drawn By Dessiné Par	BoxCad: BoxCad	Date 11-Jul-25
Material Matière	16 Ga Cold Rolled A1008 CS Type B (1.4mm)	
Color Couleur	Asa-61 Grey	Finish Fini Smooth
Description	Detail Rev.	
1412EL 19.5" x 16.5" x 6" Body		
Part Number Numéro Pièce	Rev.	3
<b>1412EL191606B</b>	<b>0</b>	11

SEE BILL OF MATERIAL ON LAST PAGE

This drawing is confidential and must not be reproduced or used without the consent of EXM

Ce dessin est confidentiel et ne doit pas être reproduit ou utilisé sans le consentement de EXM

<b>STANDARD FEATURES ARE NOT LISTED IN THIS HOLE TABLE</b>			
<b>HOLE TABLE - LEFT VIEW (CUSTOM FEATURE ONLY)</b>			
CUT-OUT	XDIM	YDIM	DESCRIPTION
1	4.625	0.875	STANDOFF M6 x 10mm (Inside)

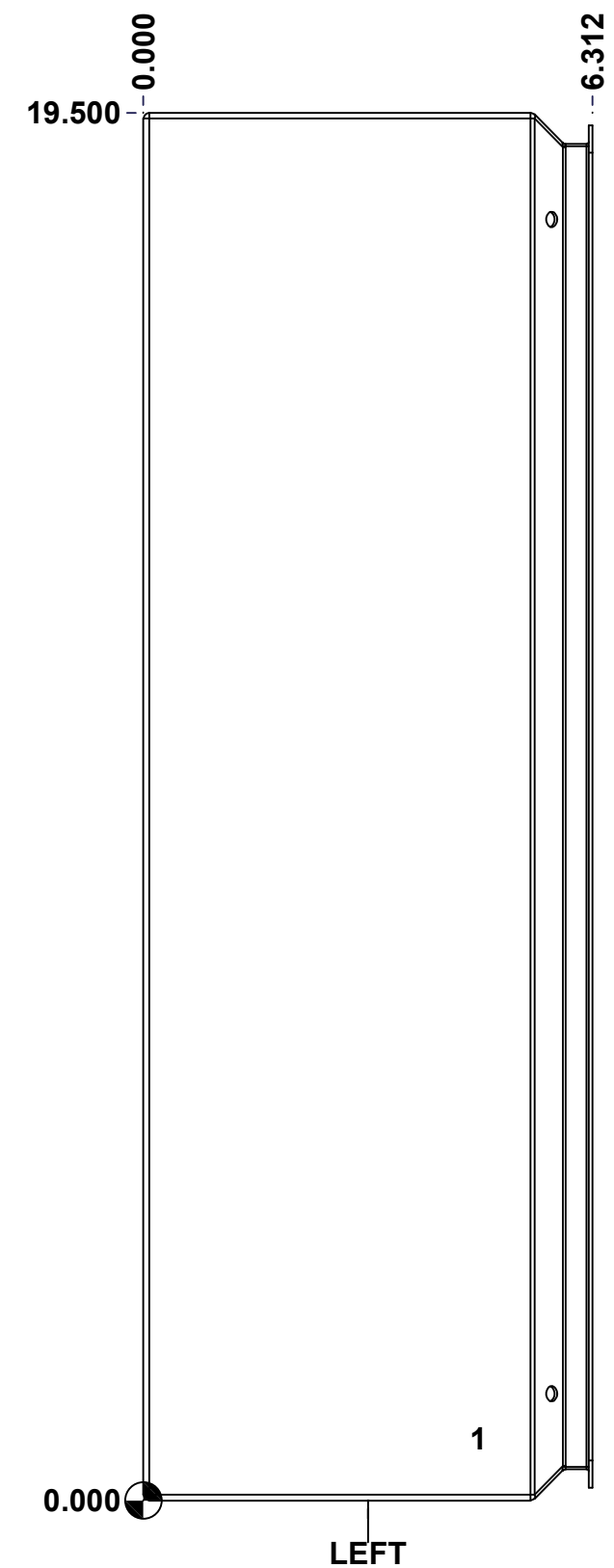

	Description	Status	
	1412EL 19.5" x 16.5" x 6" Body	(NULL)	
	Part Number Numéro Pièce	Rev.	
	<b>1412EL191606B</b>	<b>0</b>	4 11

This drawing is confidential and must not be reproduced or used without the consent of EXM

Ce dessin est confidentiel et ne doit pas être reproduit ou utilisé sans le consentement de EXM

**STANDARD FEATURES ARE NOT LISTED IN THIS HOLE TABLE**

**HOLE TABLE - BACK VIEW (CUSTOM FEATURE ONLY)**

CUT-OUT	XDIM	YDIM	DESCRIPTION
1	0.875	0.875	IP STANDOFF M6 x 10mm (Inside)
2	0.875	18.625	IP STANDOFF M6 x 10mm (Inside)
3	15.625	18.625	IP STANDOFF M6 x 10mm (Inside)
4	15.625	0.875	IP STANDOFF M6 x 10mm (Inside)
-----			
5	15.937	0.000	FOOT 885 ESCHMF1
6	0.563	0.000	FOOT 885 ESCHMF1
7	15.937	19.500	FOOT 885 ESCHMF1
8	0.563	19.500	FOOT 885 ESCHMF1
9	15.937	0.344	RIVET NUT M6_FH_CE (Inside)
10	0.563	0.344	RIVET NUT M6_FH_CE (Inside)
11	15.937	19.156	RIVET NUT M6_FH_CE (Inside)
12	0.563	19.156	RIVET NUT M6_FH_CE (Inside)

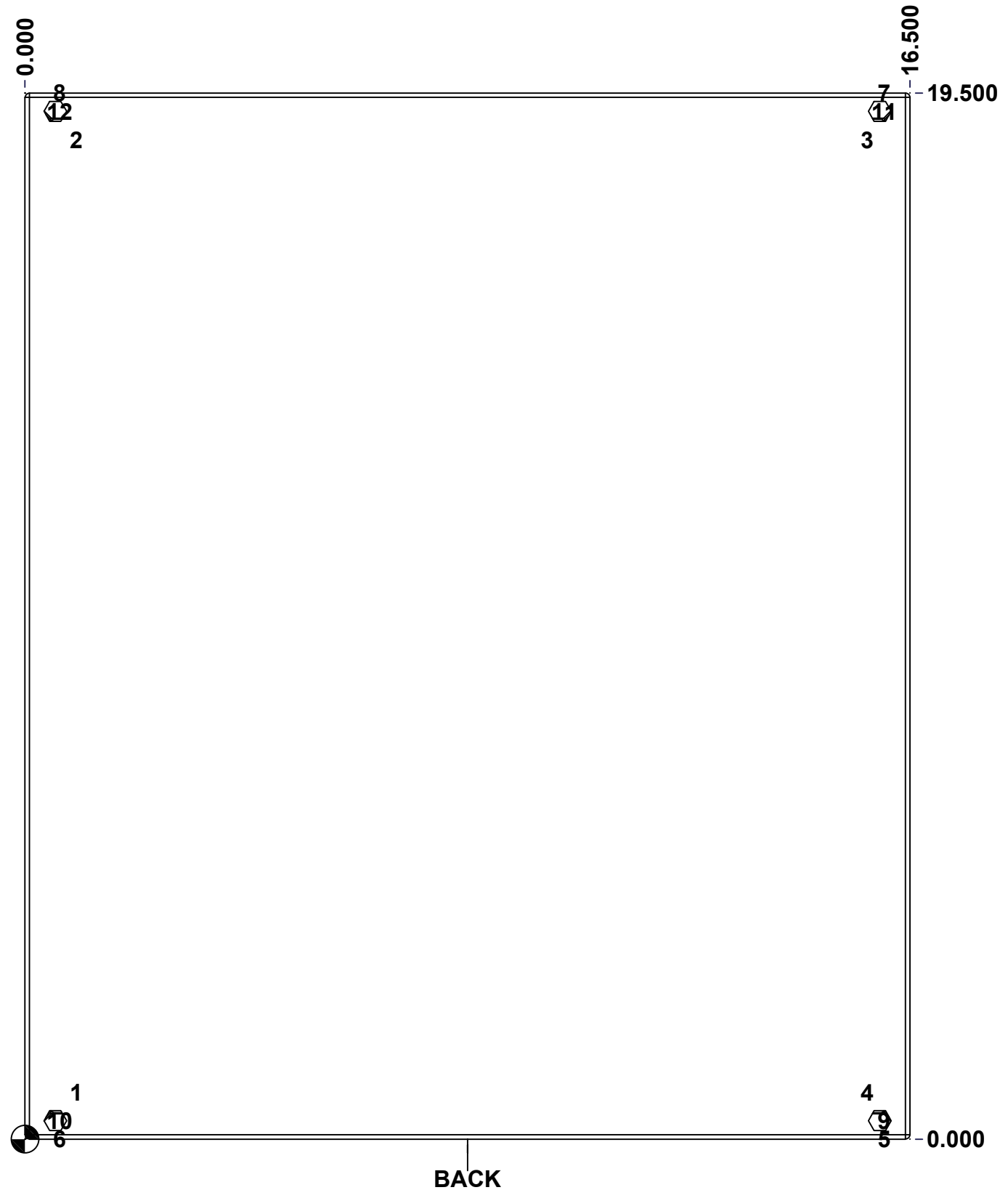

	Description	Status	
	1412EL 19.5" x 16.5" x 6" Body	(NULL)	
	Part Number Numéro Pièce	Rev.	5
	<b>1412EL191606B</b>	<b>0</b>	11

This drawing is confidential and must not be reproduced or used without the consent of EXM

Ce dessin est confidentiel et ne doit pas être reproduit ou utilisé sans le consentement de EXM

No.	Revisions	Date	By/Par

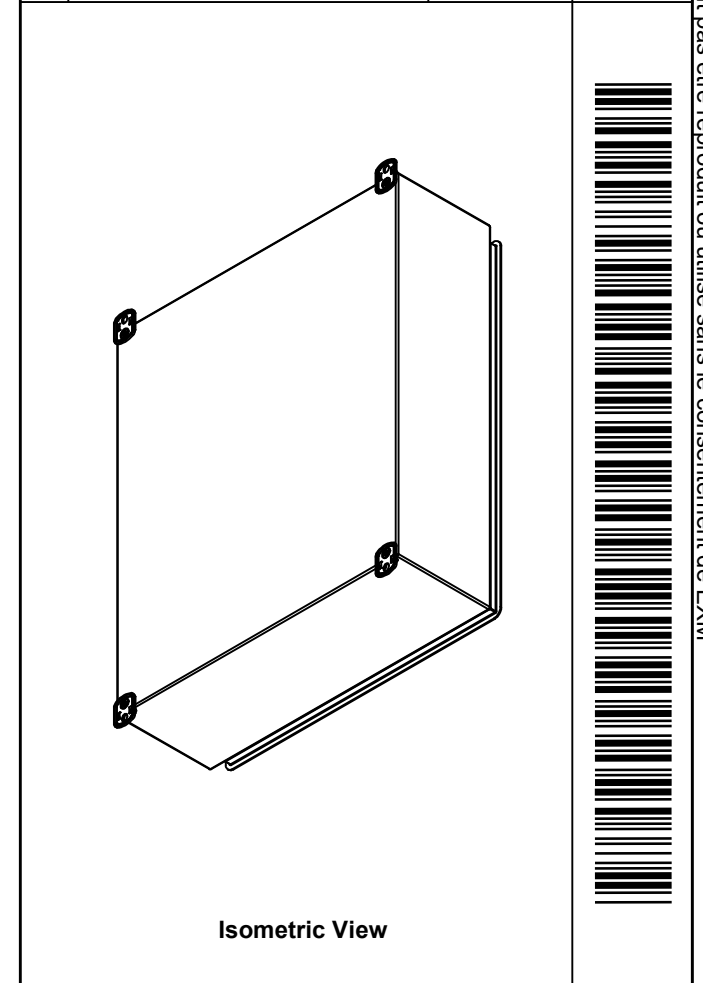



Tél: (450) 979-4373  
Fax: (450) 979-4626  
[www.exmweb.com](http://www.exmweb.com)

Flatness  
Aplatissement  
Max 3.0mm

Projection



Customer Client	Date
Drawn By / Dessiné Par: BoxCad: BoxCad	Date: 11-Jul-25
Material / Matière: 16 Ga Cold Rolled A1008 CS Type B (1.4mm)	

Color / Couleur: Asa-61 Grey	Finish / Fini: Smooth
Description: 1412EL 19.5" x 16.5" x 6" Body	
Part Number / Numéro Pièce: <b>1412EL191606B</b>	Rev. 0

Qty	Part Number	Rev	Description
4	RIVET_NUT_M6_FH_CE	0	Rivet Nut M6 (Low Profile Close End)
4	STK-Q-03071	0	M6 x 16mm Machine Screw
1	STK-P-02400S	0	Powder Paint (Asa-61 Grey / Smooth)
1	1412EL191606B-P	0	1412EL 19.5" x 16.5" x 6" Body Part
4	885 ESCHMF1	2	5412 ESCH Stamped Mounting Foot
5	STK-Q-08350	5	Standoff M6 x 10mm
Parts List			

This drawing is confidential and must not be reproduced or used without the consent of EXM

Ce dessin est confidentiel et ne doit pas être reproduit ou utilisé sans le consentement de EXM

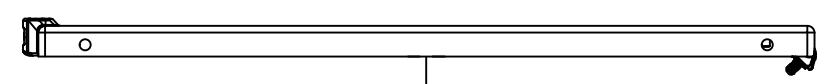

TOP

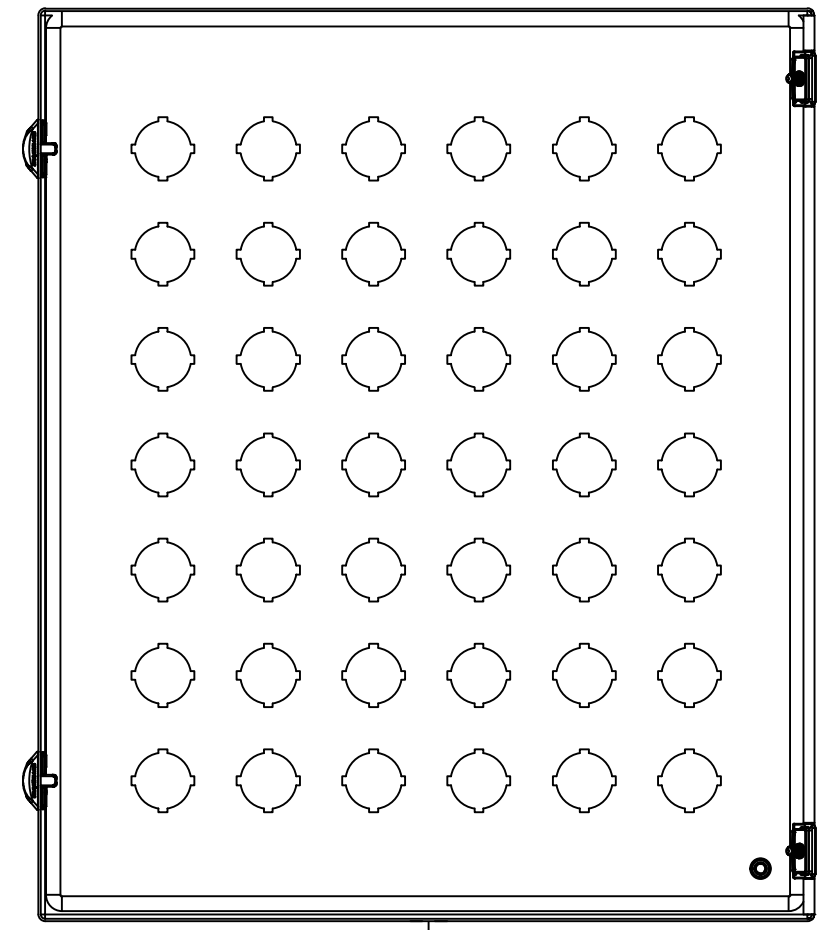

BACK



BOTTOM

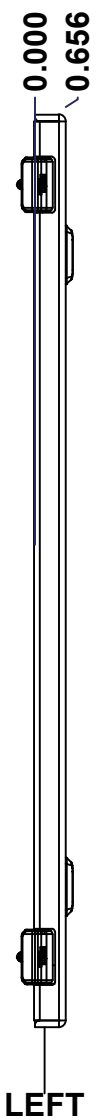

LEFT

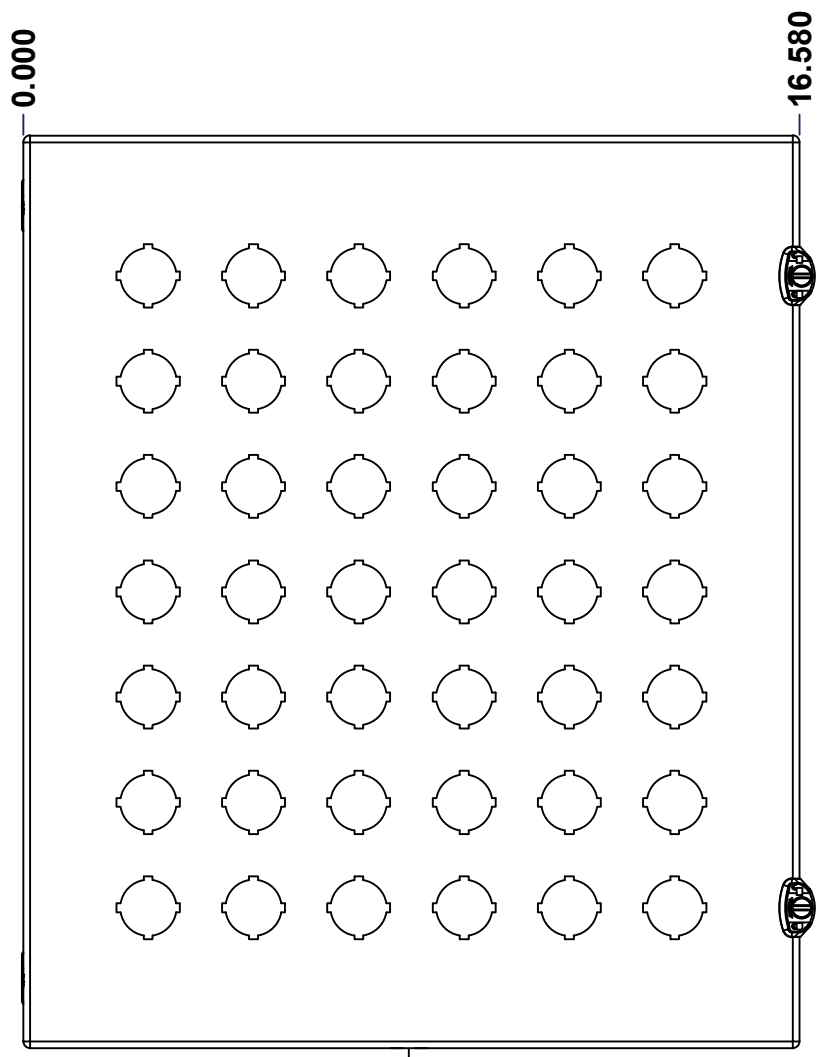

FRONT

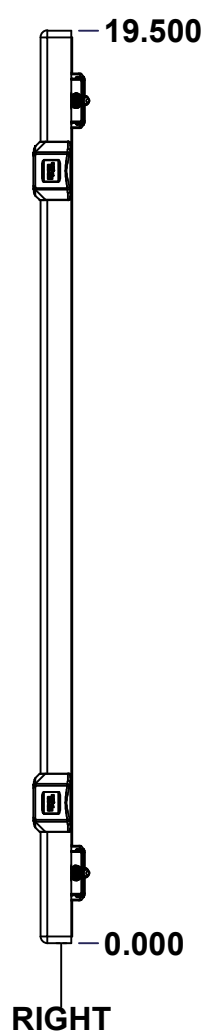

RIGHT

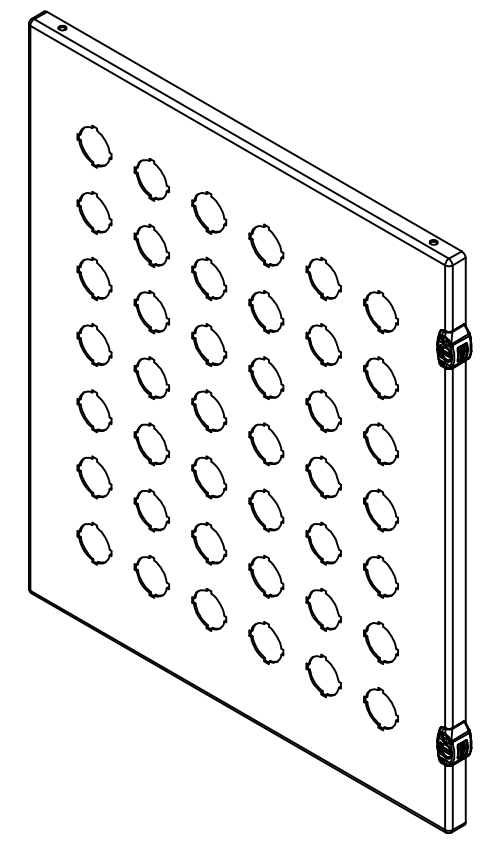

Isometric View

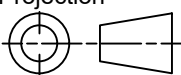

No.	Revisions	Date	By/Par

 Tél: (450) 979-4373 Fax: (450) 979-4626 <a href="http://www.exmweb.com">www.exmweb.com</a>		Flatness Aplatissement Max 3.0mm Projection 
Customer Client		Date
Drawn By Dessiné Par	BoxCad: BoxCad	Date 11-Jul-25
Material Matière	16 Ga Cold Rolled A1008 CS Type B (1.4mm)	
Color Couleur	Asa-61 Grey	Finish Fini Smooth
Description		Detail Rev.
1412EL 19.5" x 16.5" Cover		
Part Number Numéro Pièce	Rev.	
<b>1412EL191606C</b>	<b>0</b>	7 11

SEE BILL OF MATERIAL ON LAST PAGE

This drawing is confidential and must not be reproduced or used without the consent of EXM

Ce dessin est confidentiel et ne doit pas être reproduit ou utilisé sans le consentement de EXM

**STANDARD FEATURES ARE NOT LISTED IN THIS HOLE TABLE**

**HOLE TABLE - FRONT VIEW (CUSTOM FEATURE ONLY)**

CUT-OUT	XDIM	YDIM	DESCRIPTION
1	13.915	9.750	30.5 mm Standard Pushbutton
2	13.915	12.000	30.5 mm Standard Pushbutton
3	13.915	14.250	30.5 mm Standard Pushbutton
4	13.915	16.500	30.5 mm Standard Pushbutton
5	13.915	3.000	30.5 mm Standard Pushbutton
6	13.915	5.250	30.5 mm Standard Pushbutton
7	13.915	7.500	30.5 mm Standard Pushbutton
8	11.665	3.000	30.5 mm Standard Pushbutton
9	11.665	5.250	30.5 mm Standard Pushbutton
10	11.665	7.500	30.5 mm Standard Pushbutton
11	11.665	9.750	30.5 mm Standard Pushbutton
12	11.665	12.000	30.5 mm Standard Pushbutton
13	11.665	14.250	30.5 mm Standard Pushbutton
14	11.665	16.500	30.5 mm Standard Pushbutton
15	9.415	3.000	30.5 mm Standard Pushbutton
16	9.415	5.250	30.5 mm Standard Pushbutton
17	9.415	7.500	30.5 mm Standard Pushbutton
18	9.415	9.750	30.5 mm Standard Pushbutton
19	9.415	12.000	30.5 mm Standard Pushbutton
20	9.415	14.250	30.5 mm Standard Pushbutton
21	9.415	16.500	30.5 mm Standard Pushbutton
22	7.165	3.000	30.5 mm Standard Pushbutton
23	7.165	5.250	30.5 mm Standard Pushbutton
24	7.165	7.500	30.5 mm Standard Pushbutton
25	7.165	9.750	30.5 mm Standard Pushbutton
26	7.165	12.000	30.5 mm Standard Pushbutton
27	7.165	14.250	30.5 mm Standard Pushbutton
28	7.165	16.500	30.5 mm Standard Pushbutton
29	4.915	3.000	30.5 mm Standard Pushbutton
30	4.915	5.250	30.5 mm Standard Pushbutton
31	4.915	7.500	30.5 mm Standard Pushbutton
32	4.915	9.750	30.5 mm Standard Pushbutton
33	4.915	12.000	30.5 mm Standard Pushbutton
34	4.915	14.250	30.5 mm Standard Pushbutton
35	4.915	16.500	30.5 mm Standard Pushbutton
36	2.665	3.000	30.5 mm Standard Pushbutton
37	2.665	5.250	30.5 mm Standard Pushbutton
38	2.665	7.500	30.5 mm Standard Pushbutton
39	2.665	9.750	30.5 mm Standard Pushbutton
40	2.665	12.000	30.5 mm Standard Pushbutton
41	2.665	14.250	30.5 mm Standard Pushbutton
42	2.665	16.500	30.5 mm Standard Pushbutton
43	16.580	16.500	LOCK 880 SCQ2MS @ 0.0°
44	16.580	3.000	LOCK 880 SCQ2MS @ 0.0°
45	1.145	1.125	STANDOFF M6 x 10mm (Inside)

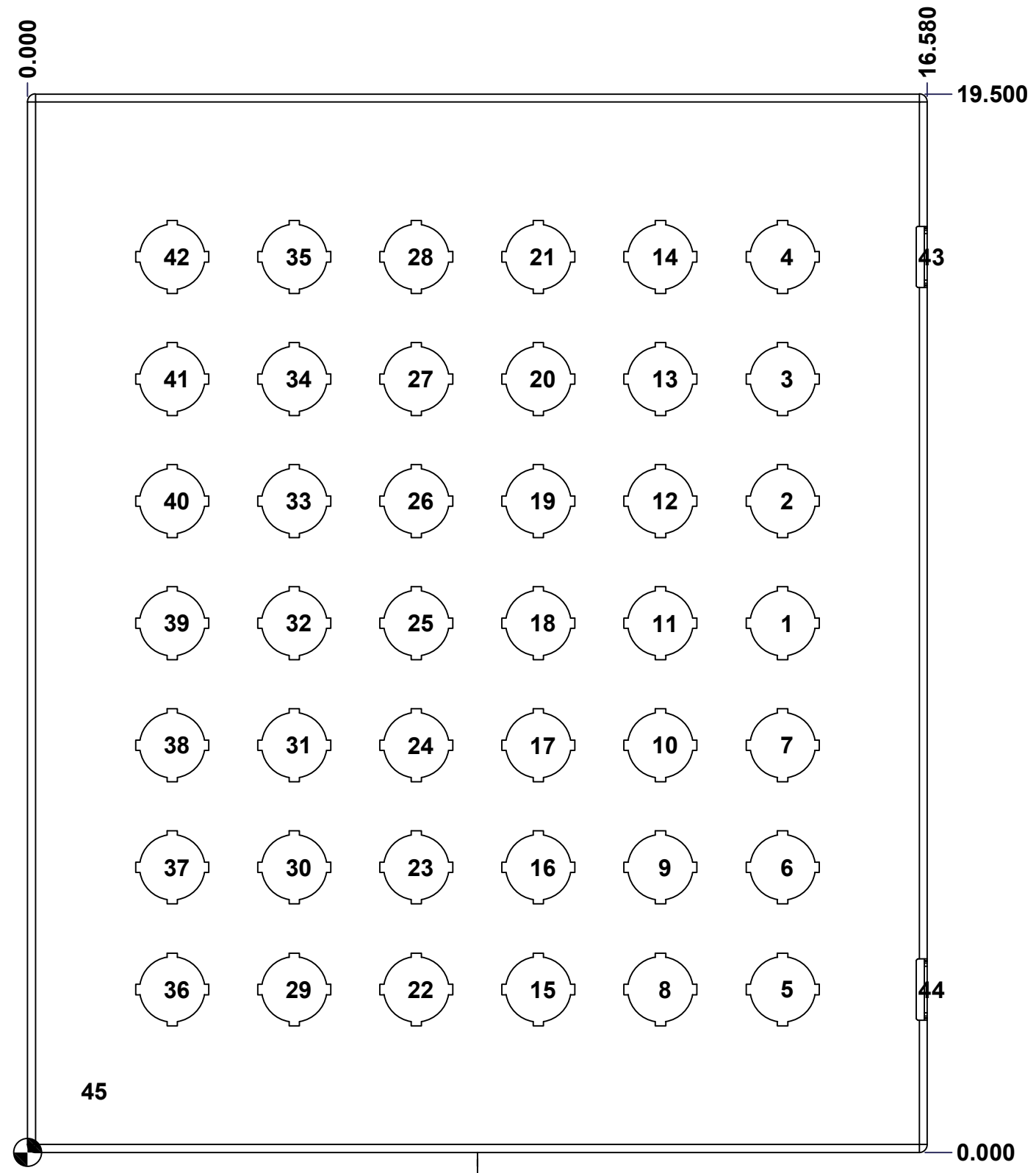

FRONT

	Description	Status
	1412EL 19.5" x 16.5" Cover	(NULL)
	Part Number Numéro Pièce	Rev. 8
	<b>1412EL191606C</b>	<b>0</b> / 11

This drawing is confidential and must not be reproduced or used without the consent of EXM

Ce dessin est confidentiel et ne doit pas être reproduit ou utilisé sans le consentement de EXM

No.	Revisions	Date	By/Par

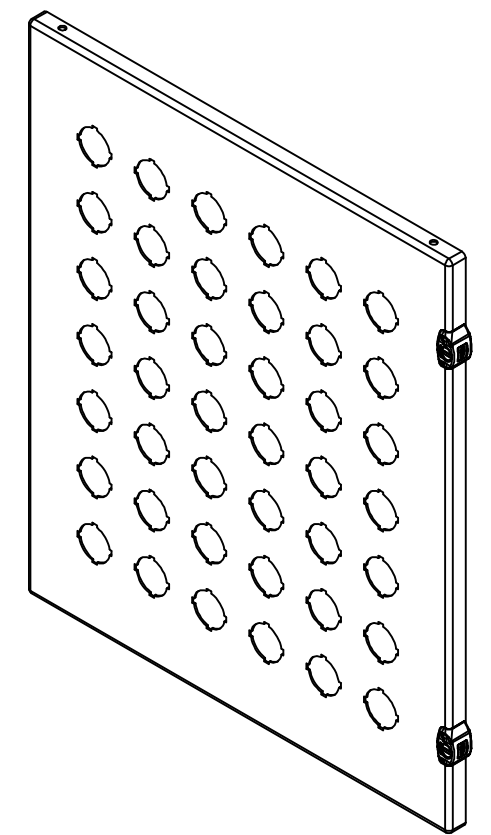

Isometric View

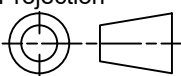

 Tél: (450) 979-4373 Fax: (450) 979-4626 <a href="http://www.exmweb.com">www.exmweb.com</a>	Flatness Aplatissement	Max 3.0mm
	Projection	
Customer Client	Date	
Drawn By Dessiné Par	BoxCad: BoxCad	Date 11-Jul-25
Material Matière	16 Ga Cold Rolled A1008 CS Type B (1.4mm)	
Color Couleur	Asa-61 Grey	Finish Fini Smooth
Description	Detail Rev.	
1412EL 19.5" x 16.5" Cover		
Part Number Numéro Pièce	Rev.	9
<b>1412EL191606C</b>	<b>0</b>	11

Qty	Part Number	Rev	Description
1	STK-Q-08350	5	Standoff M6 x 10mm
1	1412EL191606G	0	1412EL 19.5" x 16.5" Gasket
1	STK-P-02400S	0	Powder Paint (Asa-61 Grey / Smooth)
1	1412EL191606C-P	0	1412EL 19.5" x 16.5" Cover Part
2	STK-A-33033	4	5412 ESMCH Hinge
2	STK-A-79960	14	5412 ESMCH - External Lock Assy - Slot Lock
Parts List			

This drawing is confidential and must not be reproduced or used without the consent of EXM

Ce dessin est confidentiel et ne doit pas être reproduit ou utilisé sans le consentement de EXM

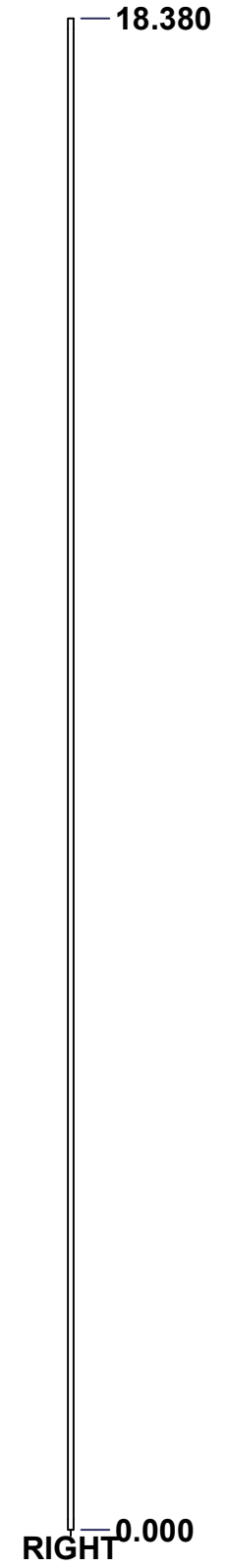
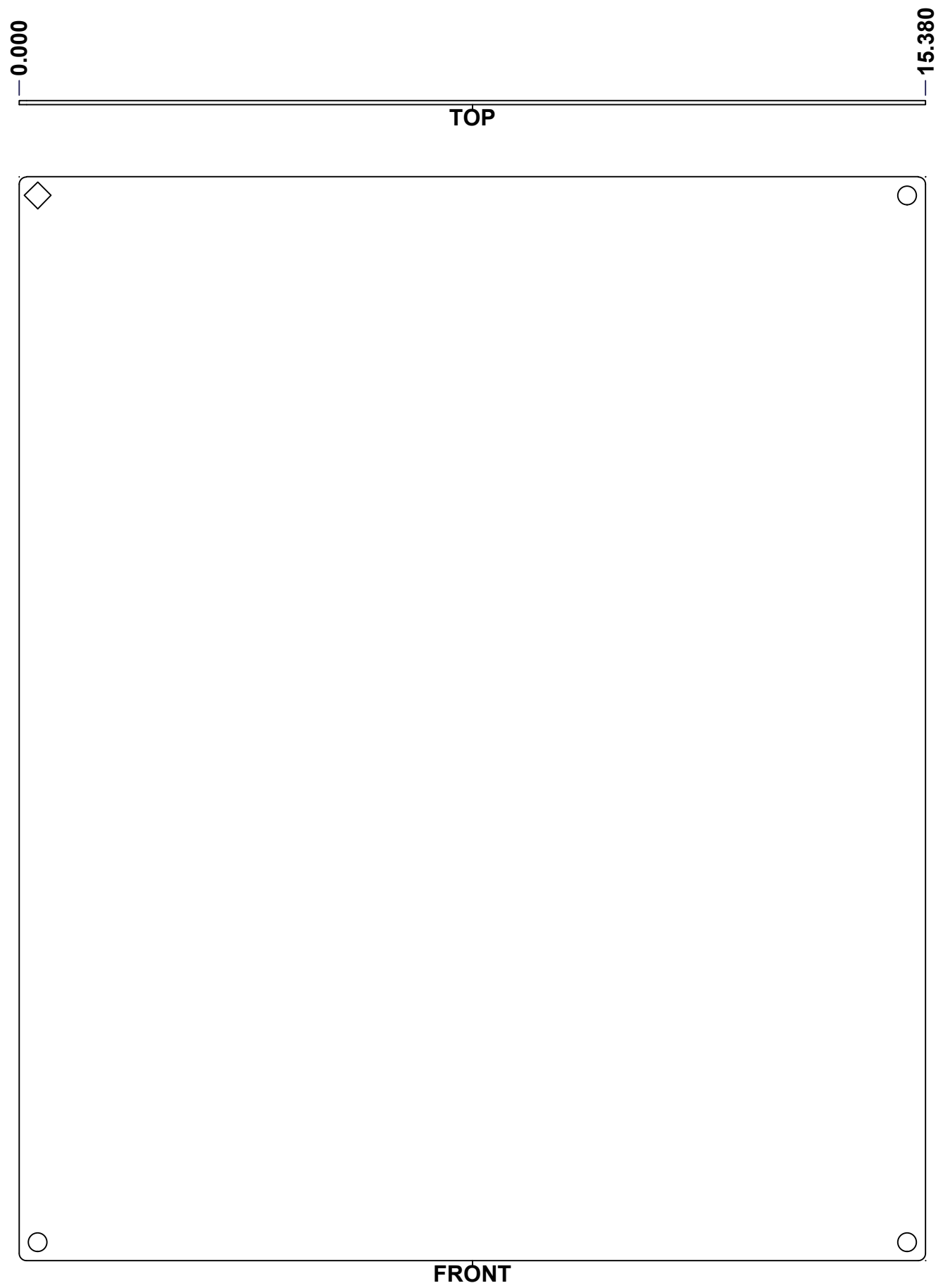

No.	Revisions	Date	By/Par

**Isometric View**

Tél: (450) 979-4373 Fax: (450) 979-4626 <a href="http://www.exmweb.com">www.exmweb.com</a>		Flatness Aplatissement	
		Max 3.0mm	
Customer Client		Date	
Drawn By Dessiné Par BoxCad: BoxCad		Date 11-Jul-25	
Material Matière 14 Ga Galvanized (1.7mm)			
Color Couleur Unpainted		Finish Fini Unpainted	
Description 1412EL 19.5" x 16.5" Inner Panel			Detail Rev.
Part Number Numéro Pièce <b>1412EL191606IP</b>		Rev. <b>0</b>	10 11

**SEE BILL OF MATERIAL ON LAST PAGE**

This drawing is confidential and must not be reproduced or used without the consent of EXM

Ce dessin est confidentiel et ne doit pas être reproduit ou utilisé sans le consentement de EXM

No.	Revisions	Date	By/Par

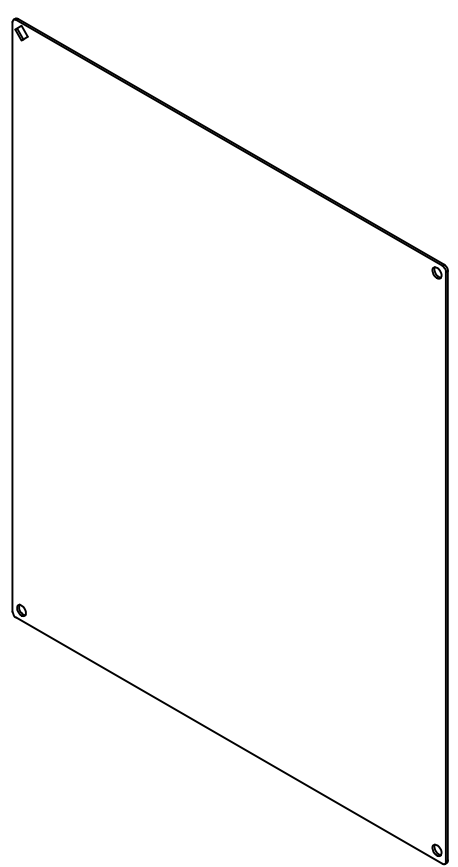

**Isometric View**

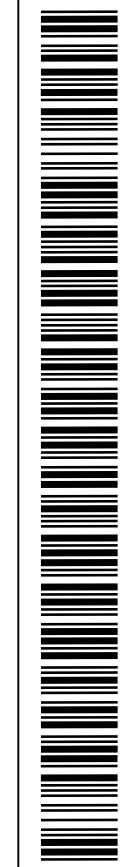

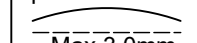
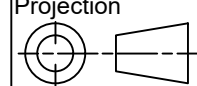
 Tél: (450) 979-4373 Fax: (450) 979-4626 <a href="http://www.exmweb.com">www.exmweb.com</a>		Flatness Aplatissement  Max 3.0mm
Projection 		
Customer Client	Date	
Drawn By Dessiné Par	BoxCad: BoxCad	Date 11-Jul-25
Material Matière	14 Ga Galvanized (1.7mm)	
Color Couleur	Unpainted	Finish Fini Unpainted
Description	Detail Rev.	
1412EL 19.5" x 16.5" Inner Panel		
Part Number Numéro Pièce	Rev.	11
<b>1412EL191606IP</b>	<b>0</b>	11

Qty	Part Number	Rev	Description
1	1412EL191606IP-P	0	1412EL 19.5" x 16.5" Inner Panel Part
Parts List			