

This drawing is confidential and must not be reproduced or used without the consent of EXM

Ce dessin est confidentiel et ne doit pas être reproduit ou utilisé sans le consentement de EXM

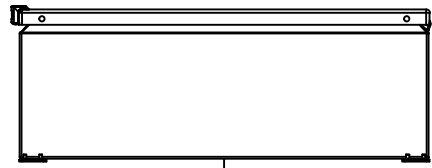

TOP

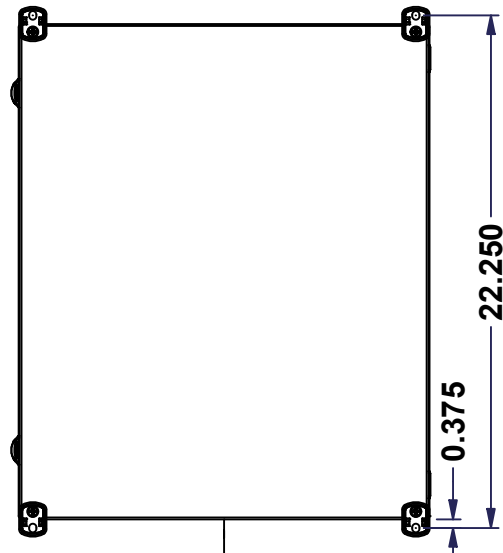

BACK

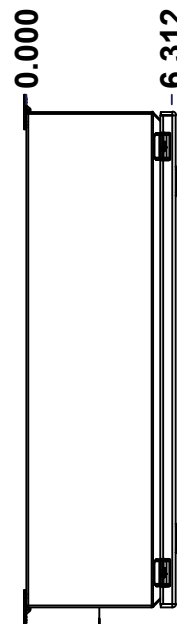

LEFT

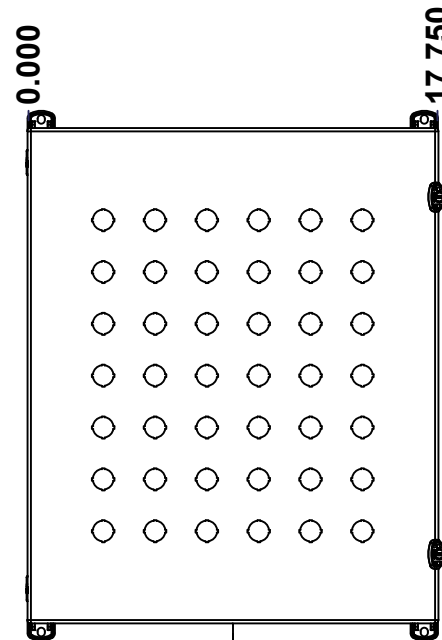

FRONT

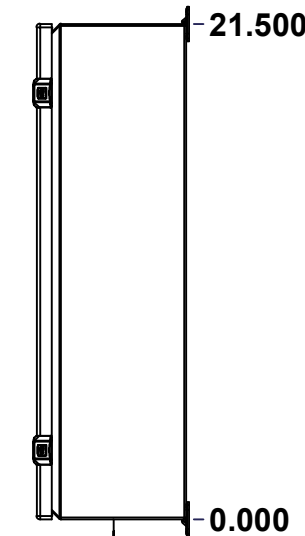

RIGHT

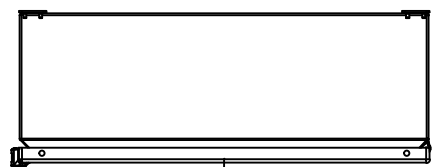

BOTTOM

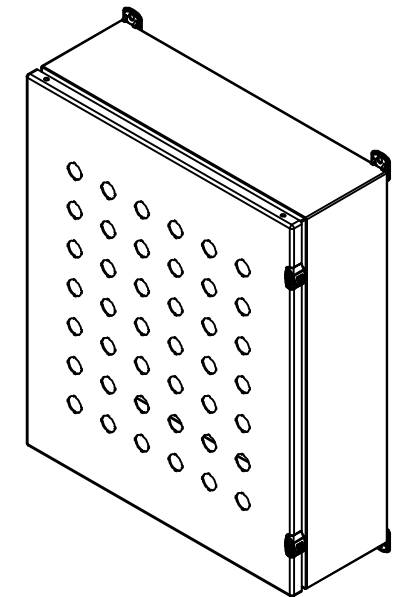

Isometric View

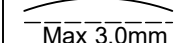
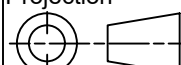

No.	Revisions	Date	By/Par

 Tél: (450) 979-4373 Fax: (450) 979-4626 <a href="http://www.exmweb.com">www.exmweb.com</a>		Flatness Aplatissement  Max 3.0mm Projection 
Customer Client		Date
Drawn By Dessiné Par	BoxCad: BoxCad	Date 11-Jul-25
Material Matière	16 Ga Cold Rolled A1008 CS Type B (1.4mm)	
Color Couleur	Asa-61 Grey	Finish Fini Smooth
Description 1412ELMN 21.5" x 17.75" x 6" Assembly		Detail Rev.
Part Number Numéro Pièce	1412EL211706MN	Rev. 1 0

SEE BILL OF MATERIAL ON LAST PAGE

This drawing is confidential and must not be reproduced or used without the consent of EXM

Ce dessin est confidentiel et ne doit pas être reproduit ou utilisé sans le consentement de EXM

NOTE	
ITEM	DESCRIPTION
1	NEMA 4, 12 Enclosure (IP66)
2	C/W Standard ground standoffs on box and cover
3	W/O Standard door stiffener
4	C/W Special inner panel (Sold separately)
5	C/W Standard inner panel mounting standoffs
6	C/W 885 ESCHMF1 Mounting Feet (Installed)

No.	Revisions	Date	By/Par

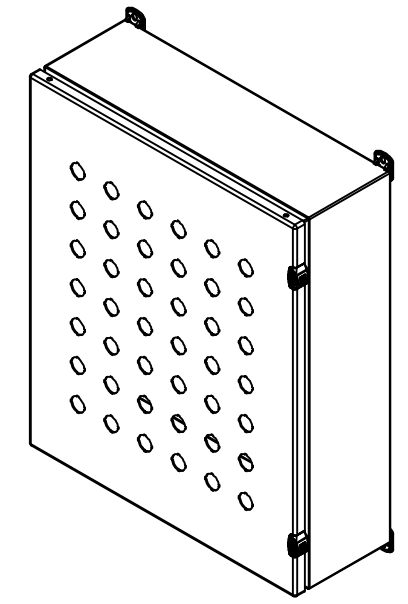

Isometric View



Tél: (450) 979-4373  
 Fax: (450) 979-4626  
[www.exmweb.com](http://www.exmweb.com)



Customer Client	Date
Drawn By / Dessiné Par: BoxCad: BoxCad	Date: 11-Jul-25
Material / Matière: 16 Ga Cold Rolled A1008 CS Type B (1.4mm)	

Color / Couleur: Asa-61 Grey	Finish / Fini: Smooth
------------------------------	-----------------------

Description: 1412ELMN 21.5" x 17.75" x 6" Assembly	Detail Rev.
--	-------------

Part Number / Numéro Pièce: <b>1412EL211706MN</b>	Rev. 0	2	11
---	--------	---	----

PACKING		
ITEM	QTY	DESCRIPTION
Cardboard sleeve	2	Top and Bottom
Cardboard strip	2	Between back of enclosure and inner panel
Plastic bag	1	To protect cover surface and inside gasket
Plastic strap - Black	2	To Squeeze the 2 cardboard sleeve together
Packaging label	1	White label with product number

Qty	Part Number	Rev	Description
1	1412EL211706MNC	0	1412ELMN 21.5" x 17.75" Cover
1	1412EL211706MNIP	0	1412EL 21.5" x 17.75" Inner Panel
1	STK-K-02910	3	5412 ESCH Accessory Kit
1	1412EL211706MNB	0	1412ELMN 21.5" x 17.75" x 6" Body

Parts List

This drawing is confidential and must not be reproduced or used without the consent of EXM

Ce dessin est confidentiel et ne doit pas être reproduit ou utilisé sans le consentement de EXM

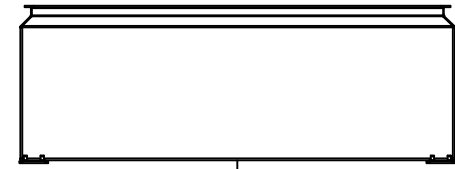

TOP

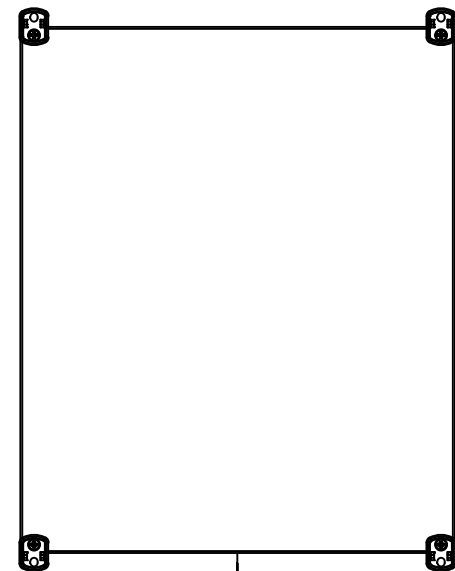

BACK

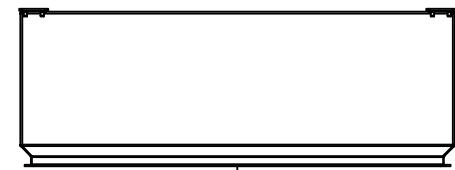

BOTTOM

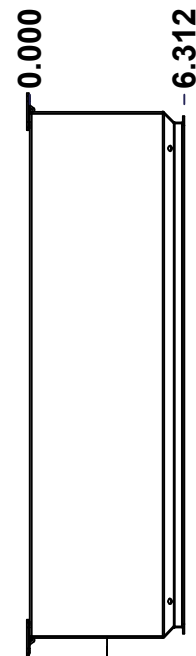

LEFT

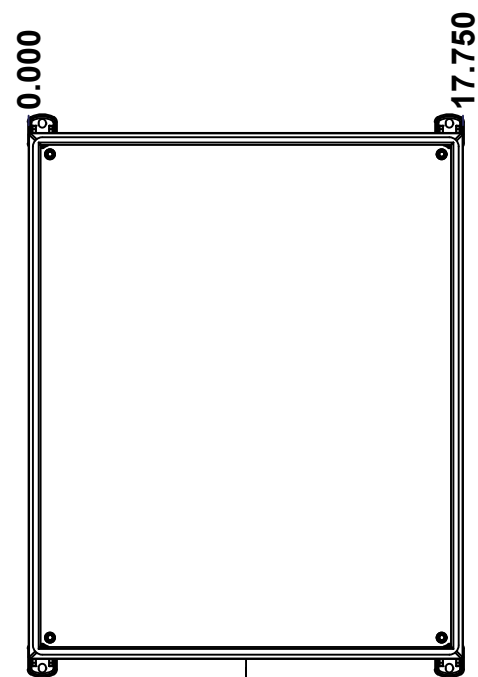

FRONT

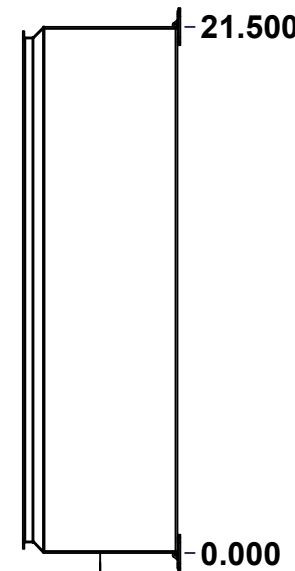

RIGHT

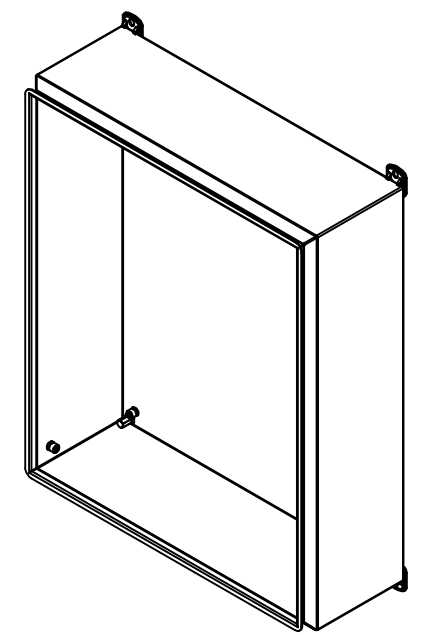

Isometric View

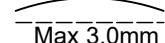
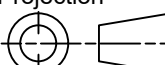

No.	Revisions	Date	By/Par

 Tél: (450) 979-4373 Fax: (450) 979-4626 <a href="http://www.exmweb.com">www.exmweb.com</a>		Flatness Aplatissement  Max 3.0mm Projection 
Customer Client	Date	
Drawn By Dessiné Par	BoxCad: BoxCad	Date 11-Jul-25
Material Matière	16 Ga Cold Rolled A1008 CS Type B (1.4mm)	
Color Couleur	Asa-61 Grey	Finish Fini Smooth
Description 1412ELMN 21.5" x 17.75" x 6" Body		Detail Rev.
Part Number Numéro Pièce	1412EL211706MNB	Rev. 3
SEE BILL OF MATERIAL ON LAST PAGE		0

This drawing is confidential and must not be reproduced or used without the consent of EXM

Ce dessin est confidentiel et ne doit pas être reproduit ou utilisé sans le consentement de EXM

<b>STANDARD FEATURES ARE NOT LISTED IN THIS HOLE TABLE</b>			
<b>HOLE TABLE - LEFT VIEW (CUSTOM FEATURE ONLY)</b>			
CUT-OUT	XDIM	YDIM	DESCRIPTION
1	4.625	0.875	STANDOFF M6 x 10mm (Inside)

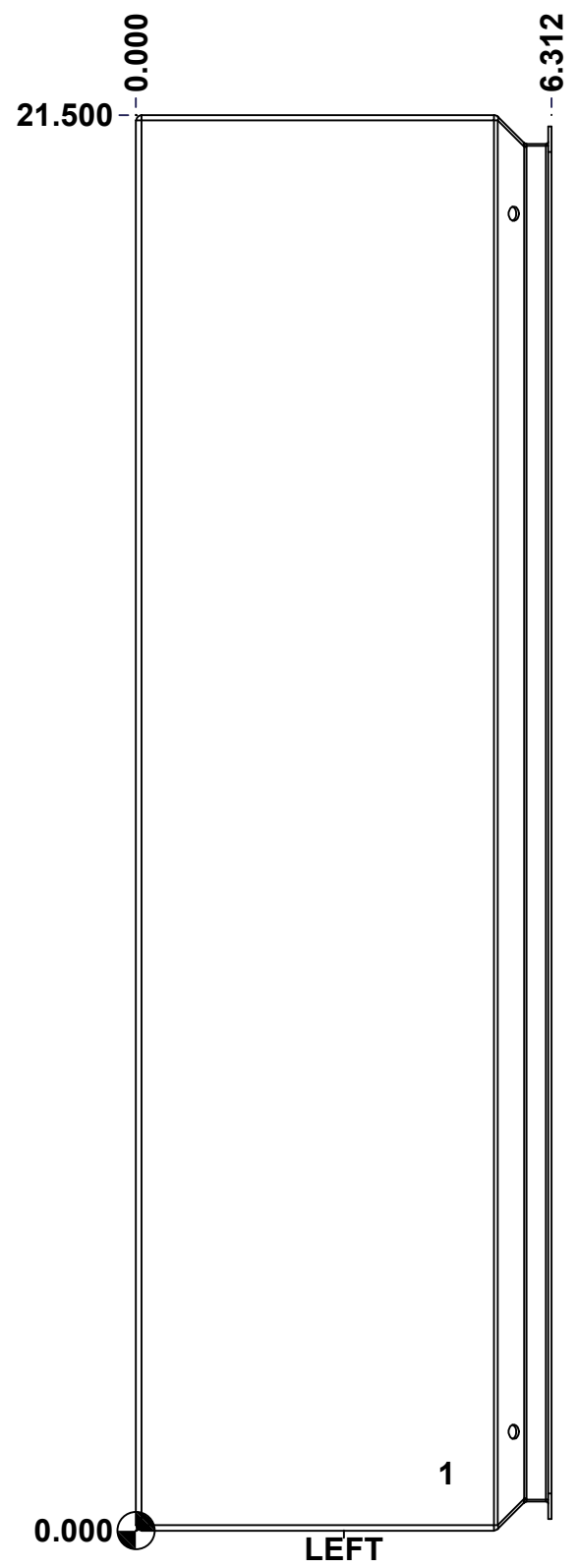

	Description	Status	
	1412EL 21.5" x 17.75" x 6" Body	(NULL)	
	Part Number Numéro Pièce	Rev.	
	<b>1412EL211706MNB</b>	<b>0</b>	4 11

This drawing is confidential and must not be reproduced or used without the consent of EXM

Ce dessin est confidentiel et ne doit pas être reproduit ou utilisé sans le consentement de EXM

**STANDARD FEATURES ARE NOT LISTED IN THIS HOLE TABLE**

**HOLE TABLE - BACK VIEW (CUSTOM FEATURE ONLY)**

CUT-OUT	XDIM	YDIM	DESCRIPTION
1	0.875	0.875	IP STANDOFF M6 x 10mm (Inside)
2	0.875	20.625	IP STANDOFF M6 x 10mm (Inside)
3	16.875	20.625	IP STANDOFF M6 x 10mm (Inside)
4	16.875	0.875	IP STANDOFF M6 x 10mm (Inside)
-----			
5	17.187	0.000	FOOT 885 ESCHMF1
6	0.563	0.000	FOOT 885 ESCHMF1
7	17.187	21.500	FOOT 885 ESCHMF1
8	0.563	21.500	FOOT 885 ESCHMF1
9	17.187	0.344	RIVET NUT M6_FH_CE (Inside)
10	0.563	0.344	RIVET NUT M6_FH_CE (Inside)
11	17.187	21.156	RIVET NUT M6_FH_CE (Inside)
12	0.563	21.156	RIVET NUT M6_FH_CE (Inside)

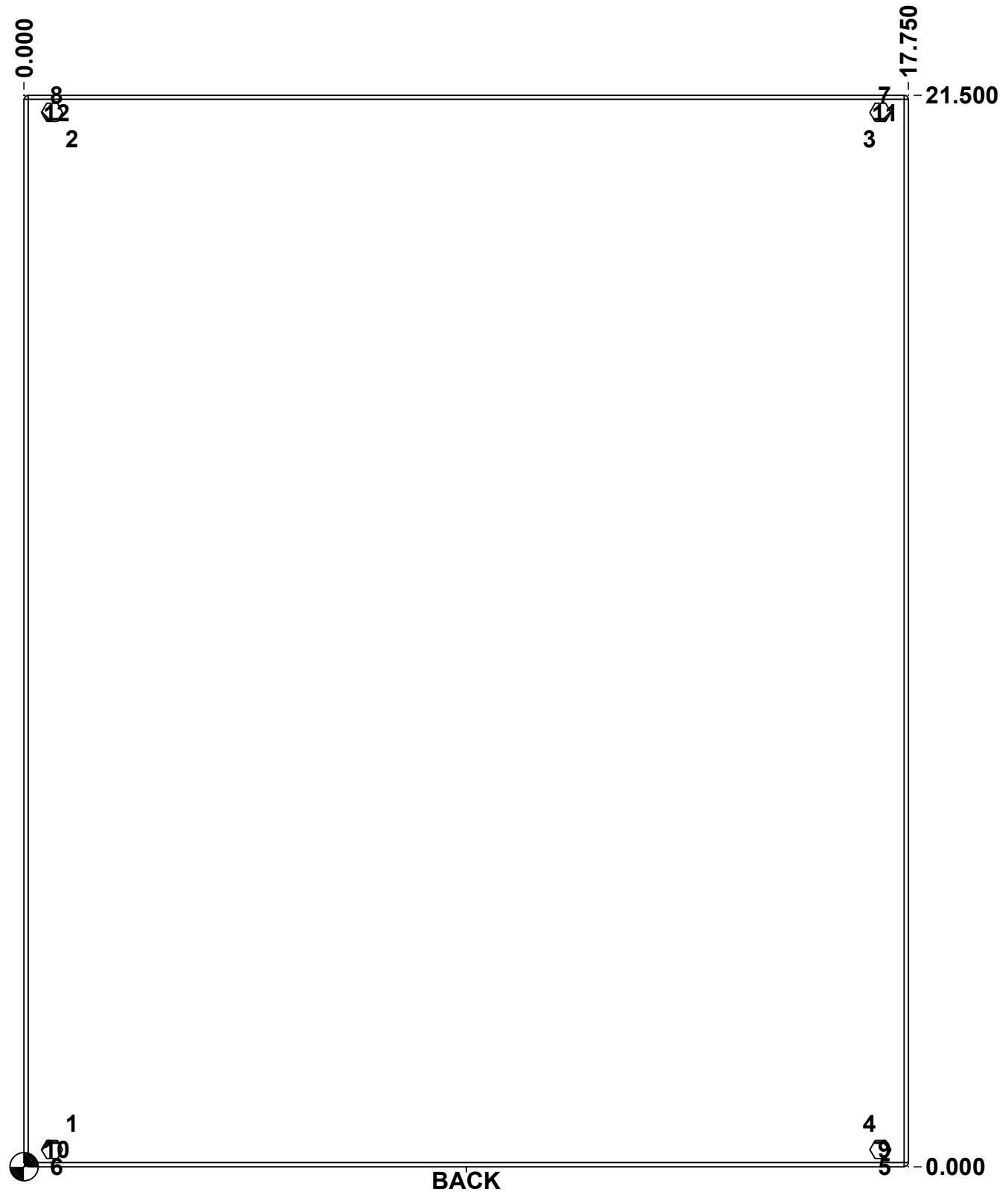



	Description	Status
	1412EL 21.5" x 17.75" x 6" Body	(NULL)
	Part Number Numéro Pièce	Rev.
	<b>1412EL211706MNB</b>	<b>0</b> / 5
		11

This drawing is confidential and must not be reproduced or used without the consent of EXM

Ce dessin est confidentiel et ne doit pas être reproduit ou utilisé sans le consentement de EXM

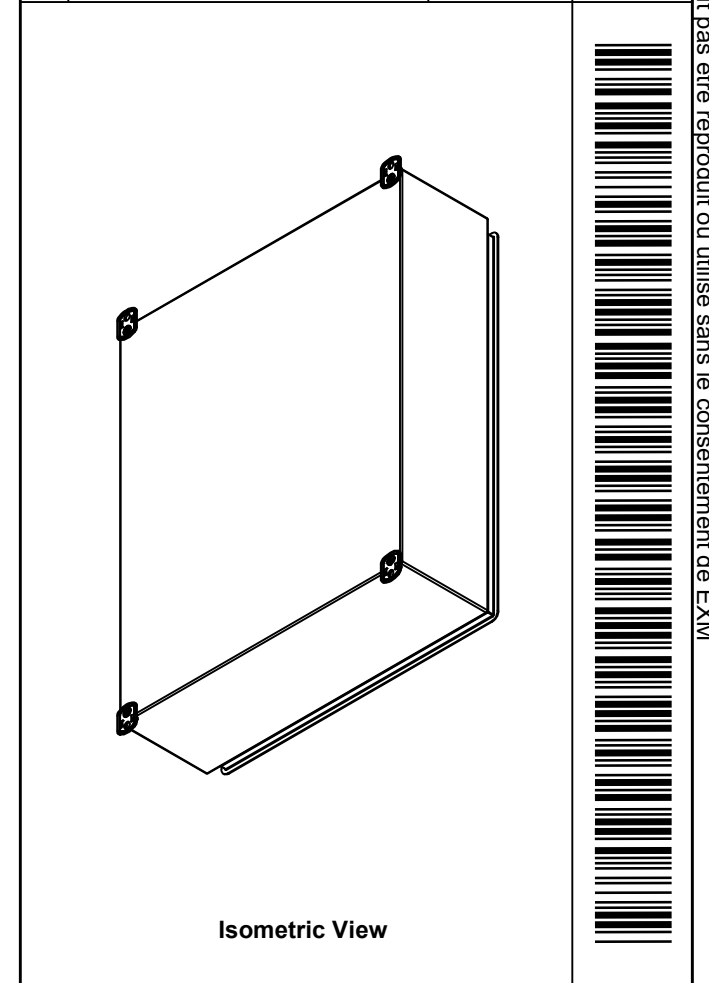
No.	Revisions	Date	By/Par

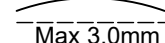
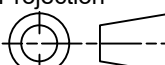

 Tél: (450) 979-4373 Fax: (450) 979-4626 <a href="http://www.exmweb.com">www.exmweb.com</a>		Flatness Aplatissement  Max 3.0mm
Customer Client		Projection 
Drawn By / Dessiné Par: BoxCad: BoxCad		Date: 11-Jul-25
Material / Matière: 16 Ga Cold Rolled A1008 CS Type B (1.4mm)		
Color / Couleur: Asa-61 Grey		Finish / Fini: Smooth
Description: 1412ELMN 21.5" x 17.75" x 6" Body		Detail Rev.
Part Number / Numéro Pièce: <b>1412EL211706MNB</b>		Rev. 0

Qty	Part Number	Rev	Description
4	RIVET_NUT_M6_FH_CE	0	Rivet Nut M6 (Low Profile Close End)
4	STK-Q-03071	0	M6 x 16mm Machine Screw
1	STK-P-02400S	0	Powder Paint (Asa-61 Grey / Smooth)
1	1412EL211706MNB-P	0	1412EL 21.5" x 17.75" x 6" Body Part
4	885 ESCHMF1	2	5412 ESCH Stamped Mounting Foot
5	STK-Q-08350	5	Standoff M6 x 10mm
Parts List			

This drawing is confidential and must not be reproduced or used without the consent of EXM

Ce dessin est confidentiel et ne doit pas être reproduit ou utilisé sans le consentement de EXM

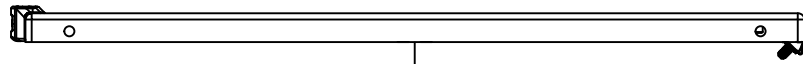

TOP

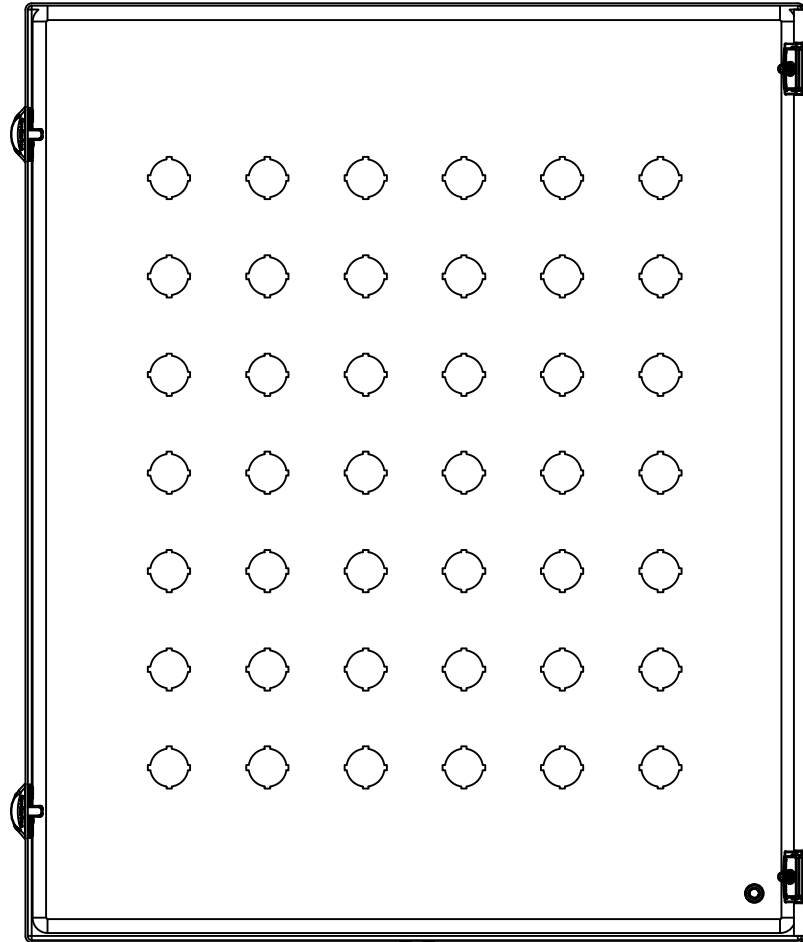

BACK

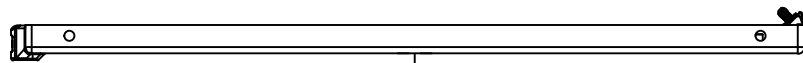

BOTTOM

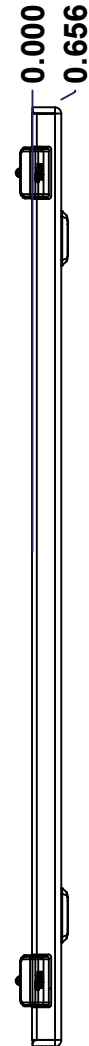

LEFT

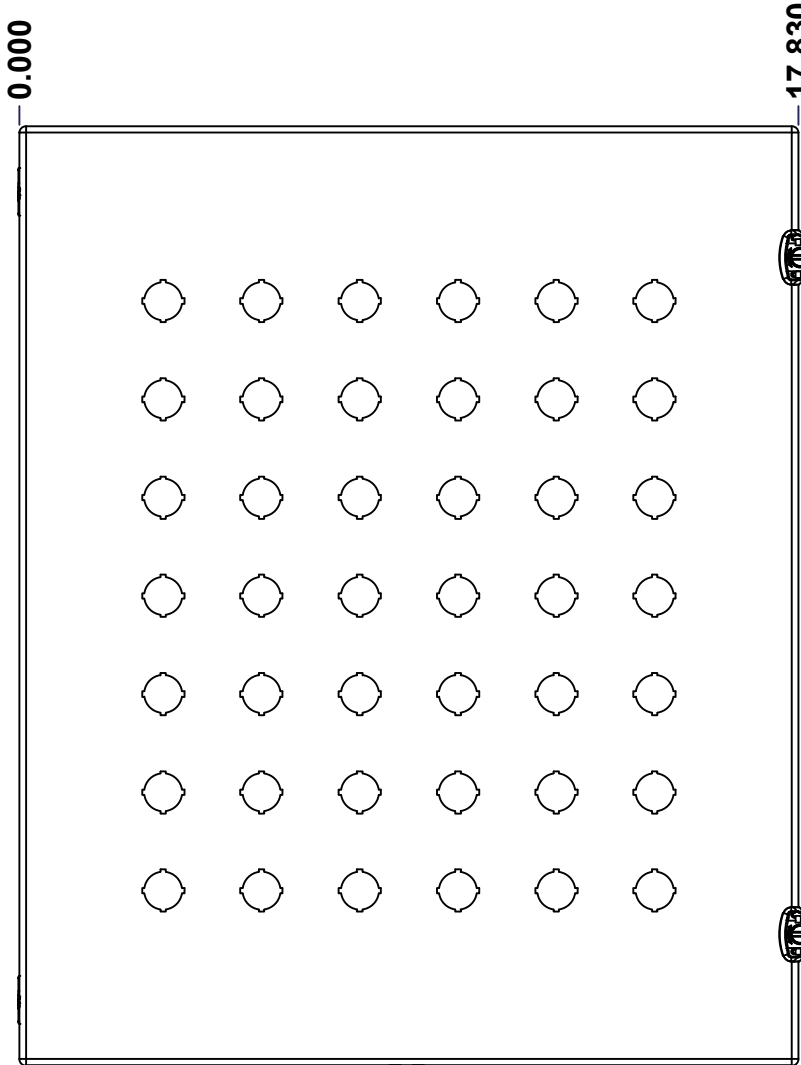

FRONT

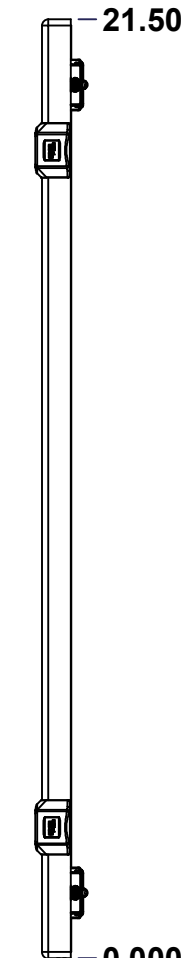

RIGHT

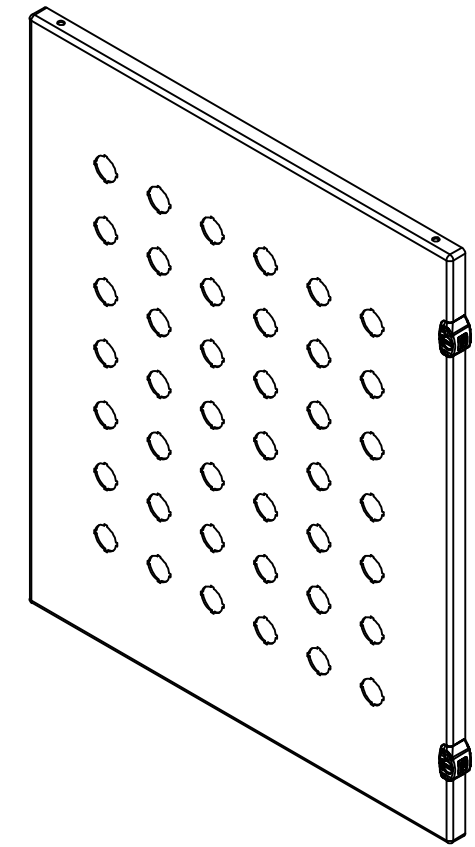

Isometric View



Tél: (450) 979-4373  
 Fax: (450) 979-4626  
[www.exmweb.com](http://www.exmweb.com)

Flatness  
Aplatissement

Max 3.0mm

Projection

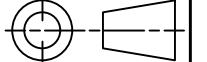

Customer Client	Date
Drawn By Dessiné Par BoxCad: BoxCad	Date 11-Jul-25
Material Matière 16 Ga Cold Rolled A1008 CS Type B (1.4mm)	
Color Couleur Asa-61 Grey	Finish Fini Smooth
Description 1412ELMN 21.5" x 17.75" Cover	Detail Rev.
Part Number Numéro Pièce <b>1412EL211706MNC</b>	Rev. <b>0</b>

SEE BILL OF MATERIAL ON LAST PAGE

This drawing is confidential and must not be reproduced or used without the consent of EXM

Ce dessin est confidentiel et ne doit pas être reproduit ou utilisé sans le consentement de EXM

**STANDARD FEATURES ARE NOT LISTED IN THIS HOLE TABLE**

**HOLE TABLE - FRONT VIEW (CUSTOM FEATURE ONLY)**

CUT-OUT	XDIM	YDIM	DESCRIPTION
1	5.540	4.000	22.5 mm Miniature Pushbutton
2	5.540	6.250	22.5 mm Miniature Pushbutton
3	5.540	8.500	22.5 mm Miniature Pushbutton
4	5.540	10.750	22.5 mm Miniature Pushbutton
5	5.540	13.000	22.5 mm Miniature Pushbutton
6	5.540	15.250	22.5 mm Miniature Pushbutton
7	5.540	17.500	22.5 mm Miniature Pushbutton
8	3.290	4.000	22.5 mm Miniature Pushbutton
9	3.290	6.250	22.5 mm Miniature Pushbutton
10	3.290	8.500	22.5 mm Miniature Pushbutton
11	3.290	10.750	22.5 mm Miniature Pushbutton
12	3.290	13.000	22.5 mm Miniature Pushbutton
13	3.290	15.250	22.5 mm Miniature Pushbutton
14	3.290	17.500	22.5 mm Miniature Pushbutton
15	14.540	4.000	22.5 mm Miniature Pushbutton
16	14.540	6.250	22.5 mm Miniature Pushbutton
17	14.540	8.500	22.5 mm Miniature Pushbutton
18	14.540	10.750	22.5 mm Miniature Pushbutton
19	14.540	13.000	22.5 mm Miniature Pushbutton
20	14.540	15.250	22.5 mm Miniature Pushbutton
21	14.540	17.500	22.5 mm Miniature Pushbutton
22	12.290	4.000	22.5 mm Miniature Pushbutton
23	12.290	6.250	22.5 mm Miniature Pushbutton
24	12.290	8.500	22.5 mm Miniature Pushbutton
25	12.290	10.750	22.5 mm Miniature Pushbutton
26	12.290	13.000	22.5 mm Miniature Pushbutton
27	12.290	15.250	22.5 mm Miniature Pushbutton
28	12.290	17.500	22.5 mm Miniature Pushbutton
29	10.040	4.000	22.5 mm Miniature Pushbutton
30	10.040	6.250	22.5 mm Miniature Pushbutton
31	10.040	8.500	22.5 mm Miniature Pushbutton
32	10.040	10.750	22.5 mm Miniature Pushbutton
33	10.040	13.000	22.5 mm Miniature Pushbutton
34	10.040	15.250	22.5 mm Miniature Pushbutton
35	10.040	17.500	22.5 mm Miniature Pushbutton
36	7.790	4.000	22.5 mm Miniature Pushbutton
37	7.790	6.250	22.5 mm Miniature Pushbutton
38	7.790	8.500	22.5 mm Miniature Pushbutton
39	7.790	10.750	22.5 mm Miniature Pushbutton
40	7.790	13.000	22.5 mm Miniature Pushbutton
41	7.790	15.250	22.5 mm Miniature Pushbutton
42	7.790	17.500	22.5 mm Miniature Pushbutton
43	17.830	18.500	LOCK 880 SCQ2MS @ 0.0°
44	17.830	3.000	LOCK 880 SCQ2MS @ 0.0°
45	1.145	1.125	STANDOFF M6 x 10mm (Inside)

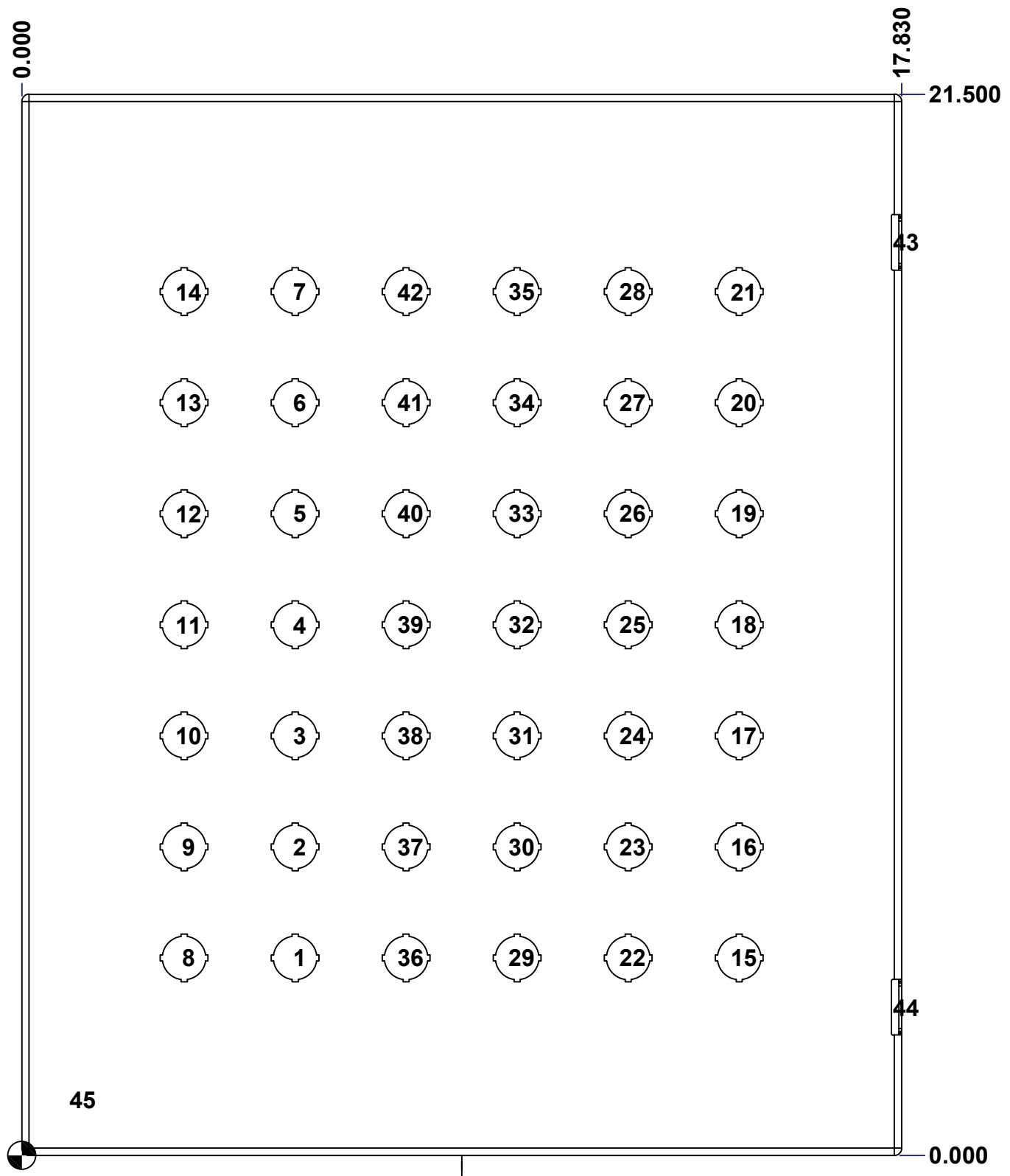

FRONT

	Description	Status
	1412EL 21.5" x 17.75" Cover	(NULL)
	Part Number	Rev.
	Numéro Pièce <b>1412EL211706MNC</b>	<b>0</b> / 8
		11

This drawing is confidential and must not be reproduced or used without the consent of EXM

Ce dessin est confidentiel et ne doit pas être reproduit ou utilisé sans le consentement de EXM

No.	Revisions	Date	By/Par

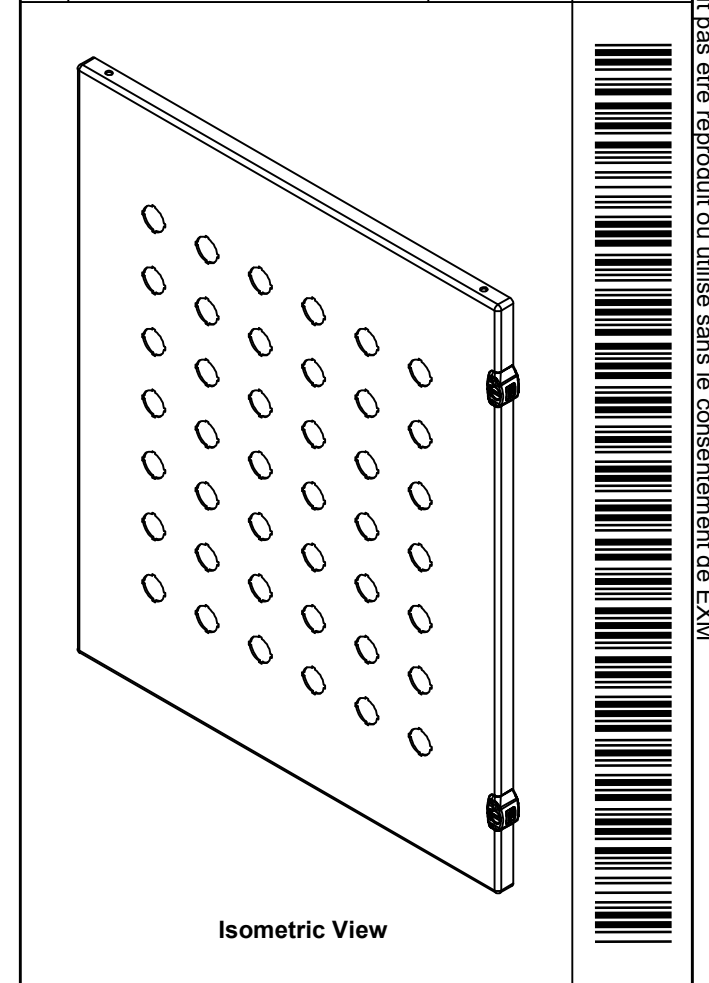

Tél: (450) 979-4373 Fax: (450) 979-4626 <a href="http://www.exmweb.com">www.exmweb.com</a>		Flatness Aplatissement	
		Max 3.0mm	
Customer Client		Date	
Drawn By Dessiné Par		Date	
Material Matière		16 Ga Cold Rolled A1008 CS Type B (1.4mm)	
Color Couleur		Asa-61 Grey	
Description		Finish Fini	
1412ELMN 21.5" x 17.75" Cover		Smooth	
Part Number Numéro Pièce		Rev.	
<b>1412EL211706MNC</b>		9	
		0	
		11	

Qty	Part Number	Rev	Description
1	STK-Q-08350	5	Standoff M6 x 10mm
1	1412EL211706MNG	0	1412EL 21.5" x 17.75" Gasket
1	STK-P-02400S	0	Powder Paint (Asa-61 Grey / Smooth)
1	1412EL211706MNC-P	0	1412EL 21.5" x 17.75" Cover Part
2	STK-A-33033	4	5412 ESMCH Hinge
2	STK-A-79960	14	5412 ESMCH - External Lock Assy - Slot Lock
Parts List			

This drawing is confidential and must not be reproduced or used without the consent of EXM

Ce dessin est confidentiel et ne doit pas être reproduit ou utilisé sans le consentement de EXM

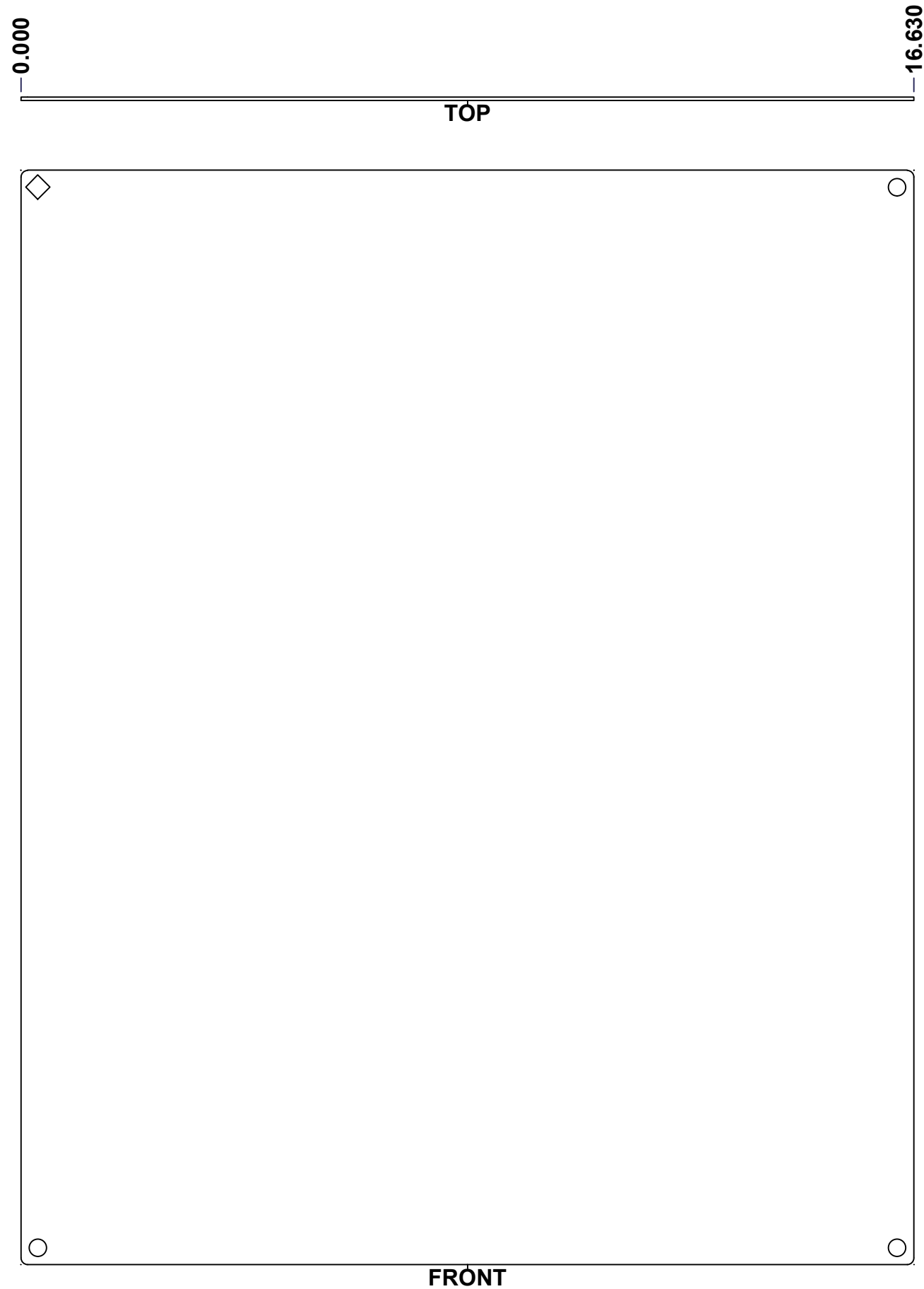

20.380

0.000

No.	Revisions	Date	By/Par

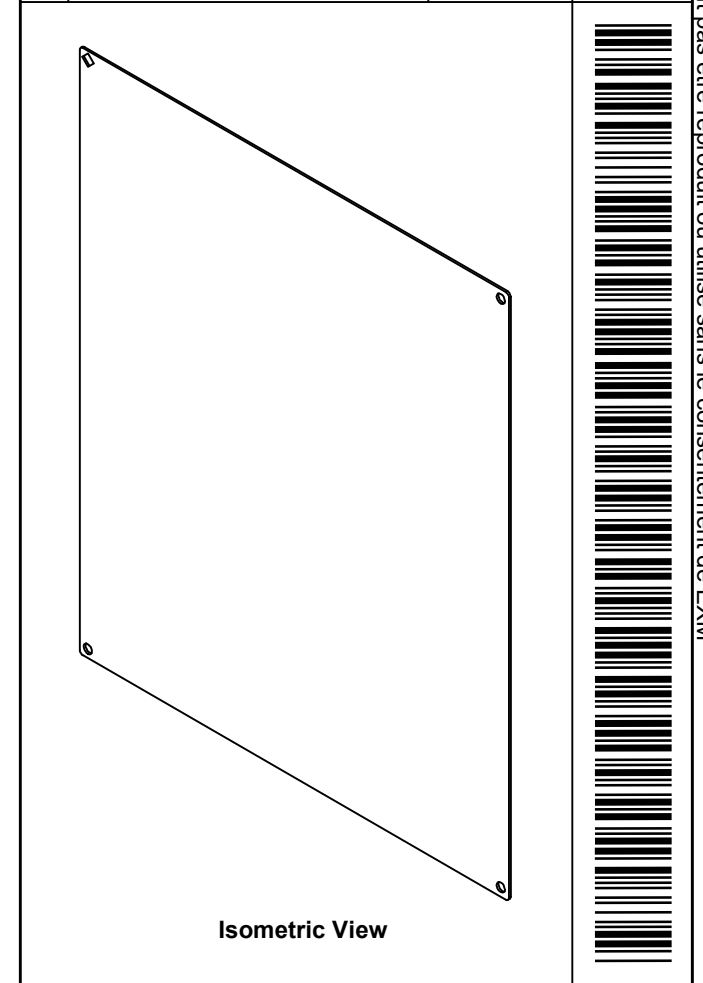

 Tél: (450) 979-4373 Fax: (450) 979-4626 <a href="http://www.exmweb.com">www.exmweb.com</a>		Flatness Aplatissement	
		Max 3.0mm	
Customer Client		Date	
Drawn By Dessiné Par BoxCad: BoxCad		Date 11-Jul-25	
Material Matière 14 Ga Galvanized (1.7mm)			
Color Couleur Unpainted		Finish Fini Unpainted	
Description 1412EL 21.5" x 17.75" Inner Panel			Detail Rev.
Part Number Numéro Pièce <b>1412EL211706MNIP</b>		Rev. <b>0</b>	10 11

**SEE BILL OF MATERIAL ON LAST PAGE**

This drawing is confidential and must not be reproduced or used without the consent of EXM

Ce dessin est confidentiel et ne doit pas être reproduit ou utilisé sans le consentement de EXM

No.	Revisions	Date	By/Par

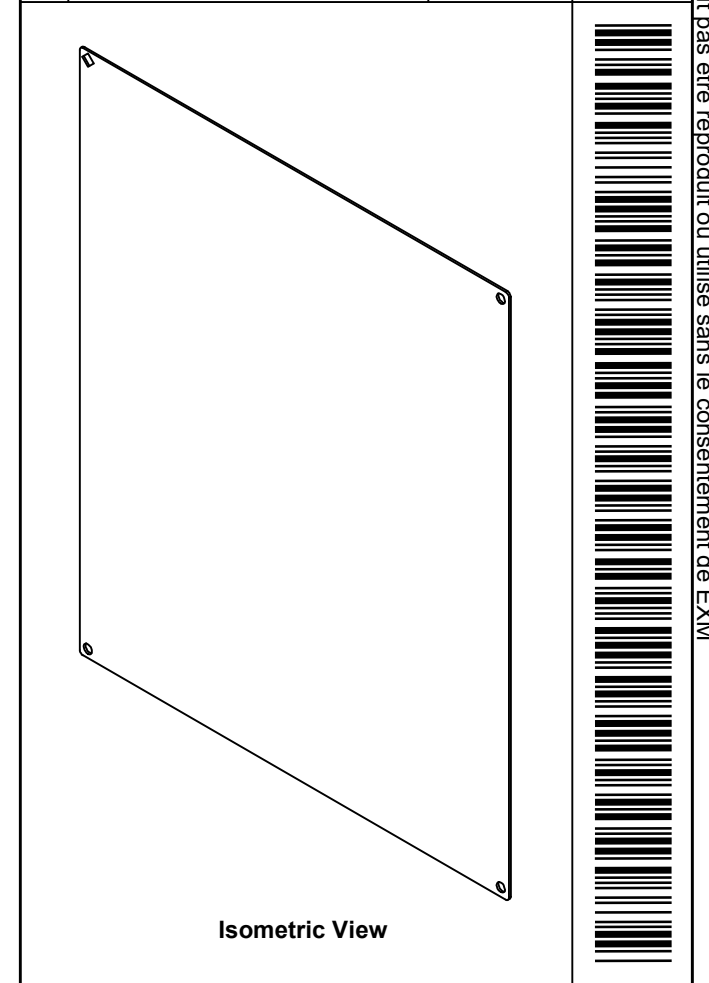

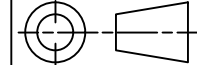
 Tél: (450) 979-4373 Fax: (450) 979-4626 <a href="http://www.exmweb.com">www.exmweb.com</a>		Flatness Aplatissement Max 3.0mm
Customer Client		Projection 
Drawn By / Dessiné Par: BoxCad: BoxCad		Date: 11-Jul-25
Material / Matière: 14 Ga Galvanized (1.7mm)		
Color / Couleur: Unpainted	Finish / Fini: Unpainted	
Description: 1412EL 21.5" x 17.75" Inner Panel		Detail Rev.
Part Number / Numéro Pièce: <b>1412EL211706MNIP</b>		Rev. 0 / 11

Qty	Part Number	Rev	Description
1	1412EL211706MNIP-P	0	1412EL 21.5" x 17.75" Inner Panel Part
Parts List			