

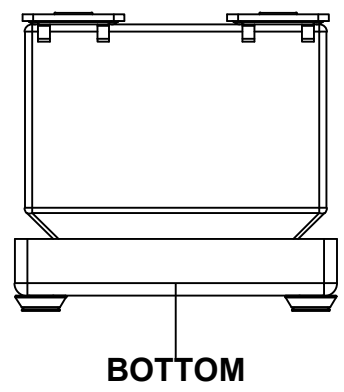

This drawing is confidential and must not be reproduced or used without the consent of EXM

Ce dessin est confidentiel et ne doit pas être reproduit ou utilisé sans le consentement de EXM

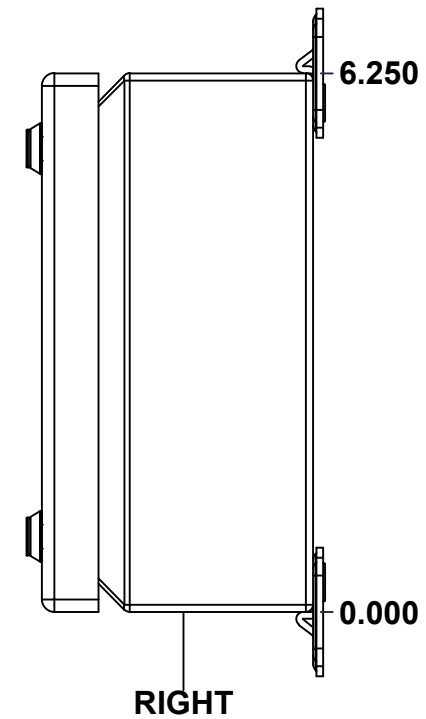
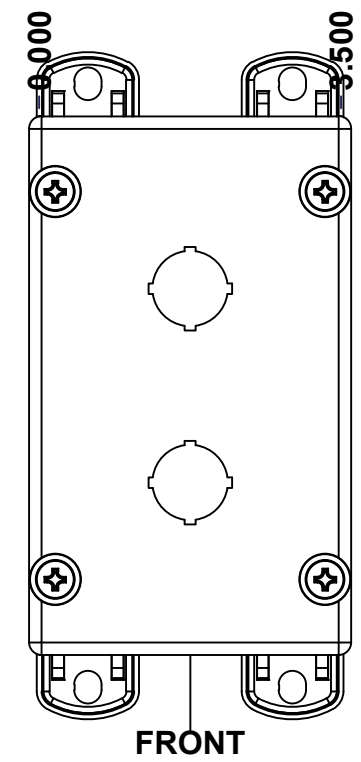
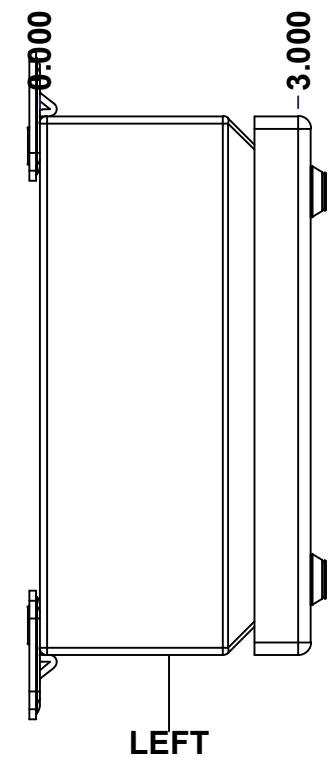
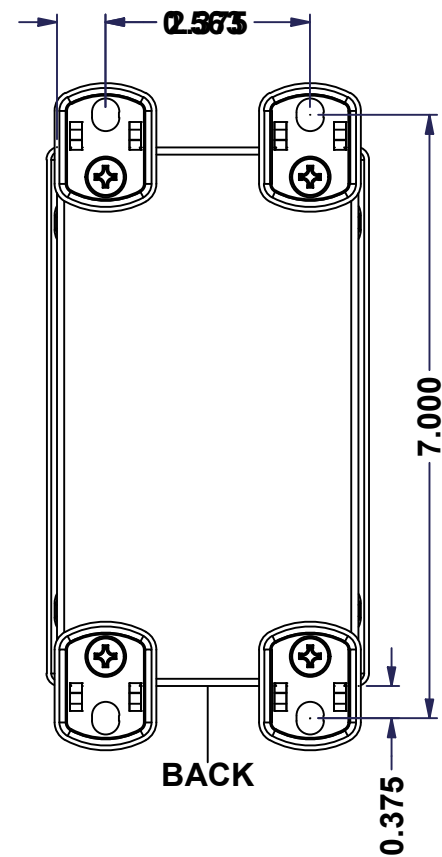
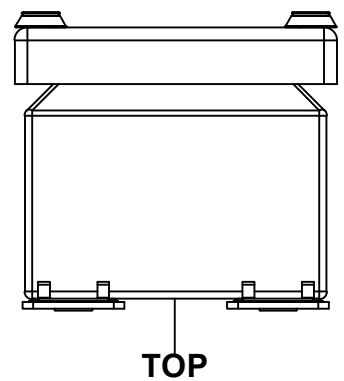
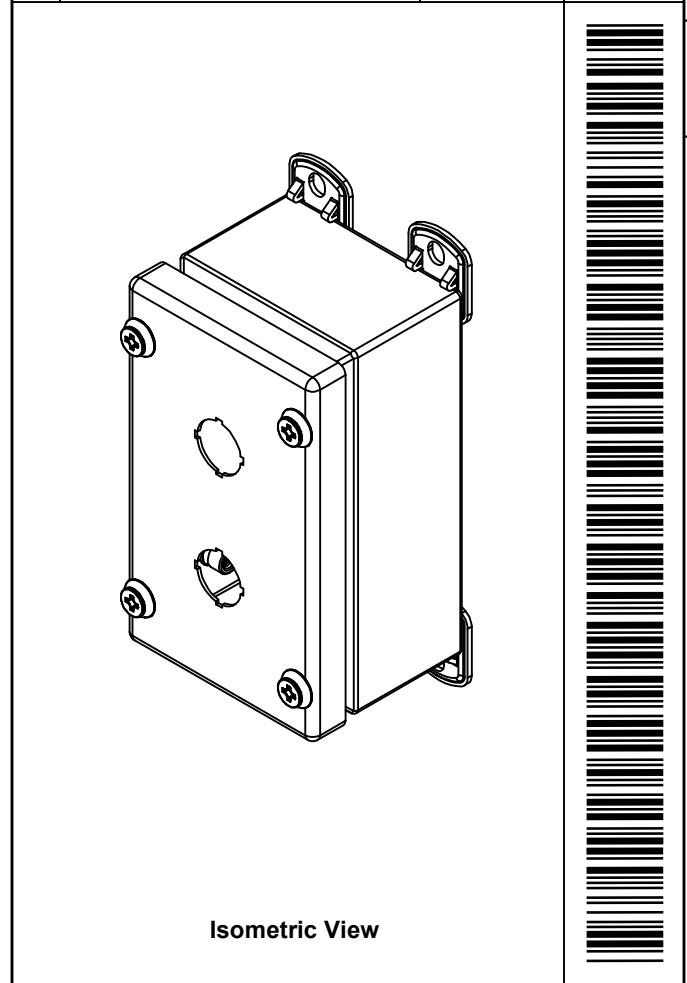

No.	Revisions	Date	By/Par

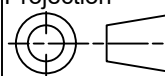

 Tél: (450) 979-4373 Fax: (450) 979-4626 www.exmweb.com		Flatness Aplatissement
		Max 3.0mm
Customer Client		Projection
		
Drawn By Dessiné Par BoxCad: BoxCad		Date 06-Apr-23
Material Matière 16 Ga Stainless Steel 304 (1.4mm)		
Color Couleur	Unpainted	Finish Fini Brushed
Description 1412SDSSMN 6.25" x 3.5" x 3" Assembly		Detail Rev.
Part Number Numéro Pièce 1412SDSS050302MN		Rev. 1 0

SEE BILL OF MATERIAL ON LAST PAGE

This drawing is confidential and must not be reproduced or used without the consent of EXM

Ce dessin est confidentiel et ne doit pas être reproduit ou utilisé sans le consentement de EXM

NOTE	
ITEM	DESCRIPTION
1	NEMA 4X Enclosure (IP66)
2	C/W Standard ground standoffs on box only
3	W/O Standard door stiffener
4	W/O Inner panel
5	W/O Inner panel mounting standoffs
6	C/W 885 ESCHMF2 Mounting Feet (Installed)

No.	Revisions	Date	By/Par

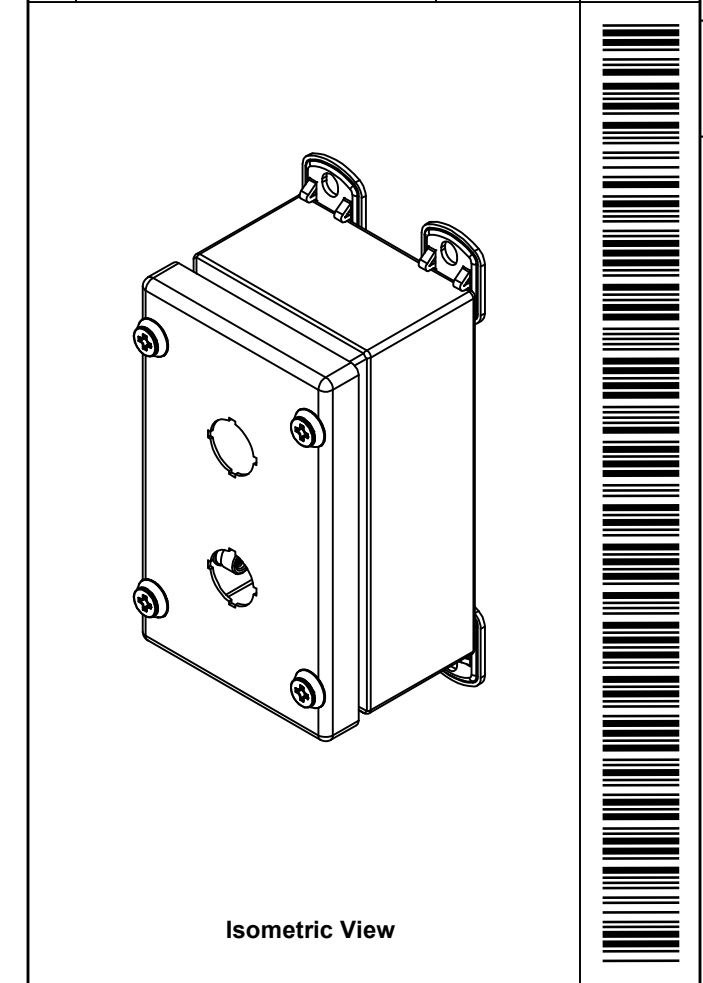

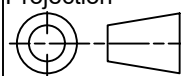
 Tél: (450) 979-4373 Fax: (450) 979-4626 www.exmweb.com		Flatness Aplatissement Max 3.0mm Projection 
Customer Client	Date	
Drawn By Dessiné Par	BoxCad: BoxCad	Date 06-Apr-23
Material Matière	16 Ga Stainless Steel 304 (1.4mm)	
Color Couleur	Unpainted	Finish Fini Brushed
Description		Detail Rev.
1412SDSSMN 6.25" x 3.5" x 3" Assembly		
Part Number Numéro Pièce	1412SDSS050302MN	Rev. 2 0 9

PACKING		
ITEM	QTY	DESCRIPTION
Cardboard sleeve	2	Top and Bottom
Cardboard strip	2	Between back of enclosure and inner panel
Plastic bag	1	To protect cover surface and inside gasket
Plastic strap - Black	2	To Squeeze the 2 cardboard sleeve together
Packaging label	1	White label with product number

Qty	Part Number	Rev	Description
1	STK-K-02925	3	5412 ESSSC Accessory Kit
1	1412SDSS050302MNC	0	1412SDSSMN 6.25" x 3.5" Cover
1	1412SDSS050302MNB	0	1412SDSSMN 6.25" x 3.5" x 3" Body
Parts List			

This drawing is confidential and must not be reproduced or used without the consent of EXM

Ce dessin est confidentiel et ne doit pas être reproduit ou utilisé sans le consentement de EXM

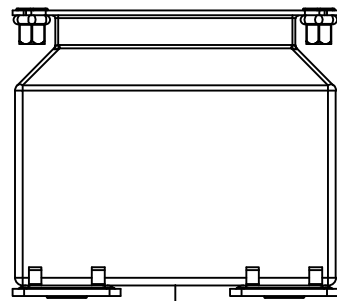

TOP

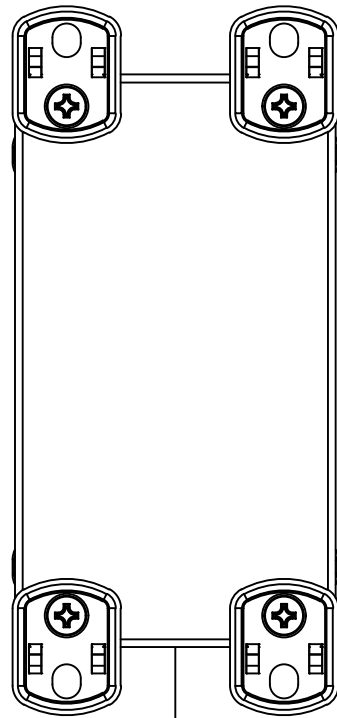

BACK

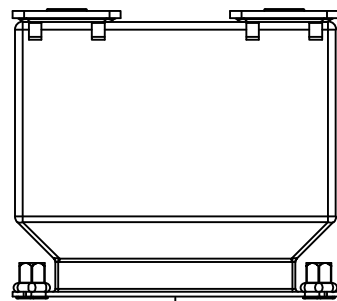

BOTTOM

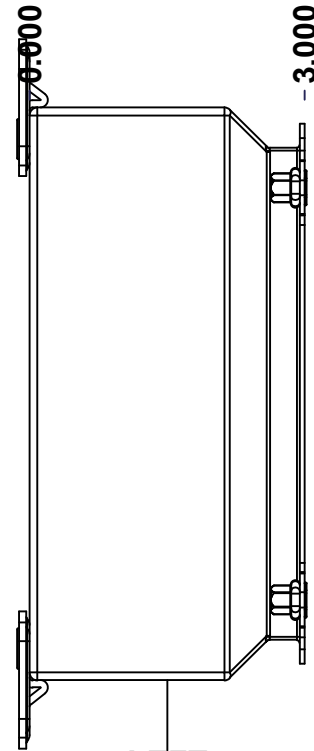

LEFT

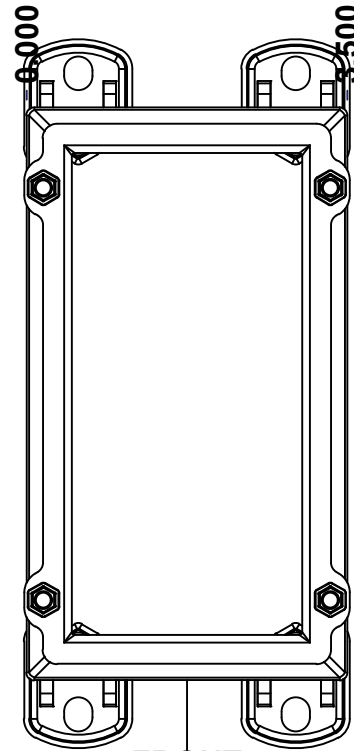

FRONT

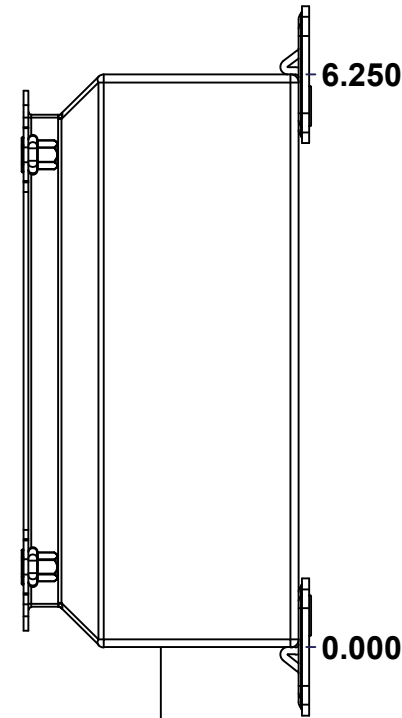

RIGHT

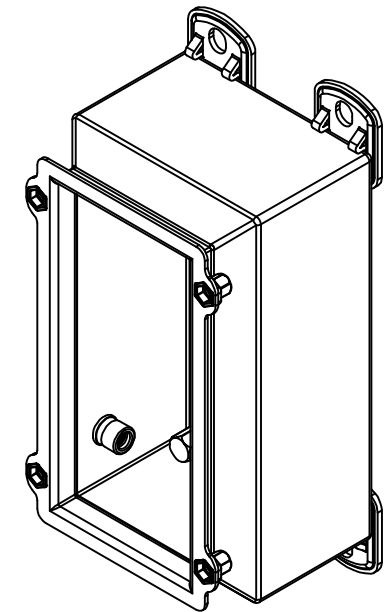

Isometric View

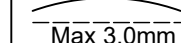

No.	Revisions	Date	By/Par

 Tél: (450) 979-4373 Fax: (450) 979-4626 www.exmweb.com		Flatness Aplatissement  Max 3.0mm
Customer Client		Date
Drawn By Dessiné Par BoxCad: BoxCad		Date 06-Apr-23
Material Matière 16 Ga Stainless Steel 304 (1.4mm)		
Color Couleur Unpainted	Finish Fini Brushed	
Description 1412SDSSMN 6.25" x 3.5" x 3" Body		Detail Rev.
Part Number Numéro Pièce 1412SDSS050302MNB		Rev. 3 0

SEE BILL OF MATERIAL ON LAST PAGE

This drawing is confidential and must not be reproduced or used without the consent of EXM

Ce dessin est confidentiel et ne doit pas être reproduit ou utilisé sans le consentement de EXM

STANDARD FEATURES ARE NOT LISTED IN THIS HOLE TABLE			
HOLE TABLE - LEFT VIEW (CUSTOM FEATURE ONLY)			
CUT-OUT	XDIM	YDIM	DESCRIPTION
1	1.625	0.875	STANDOFF M6 x 10mm (Inside)

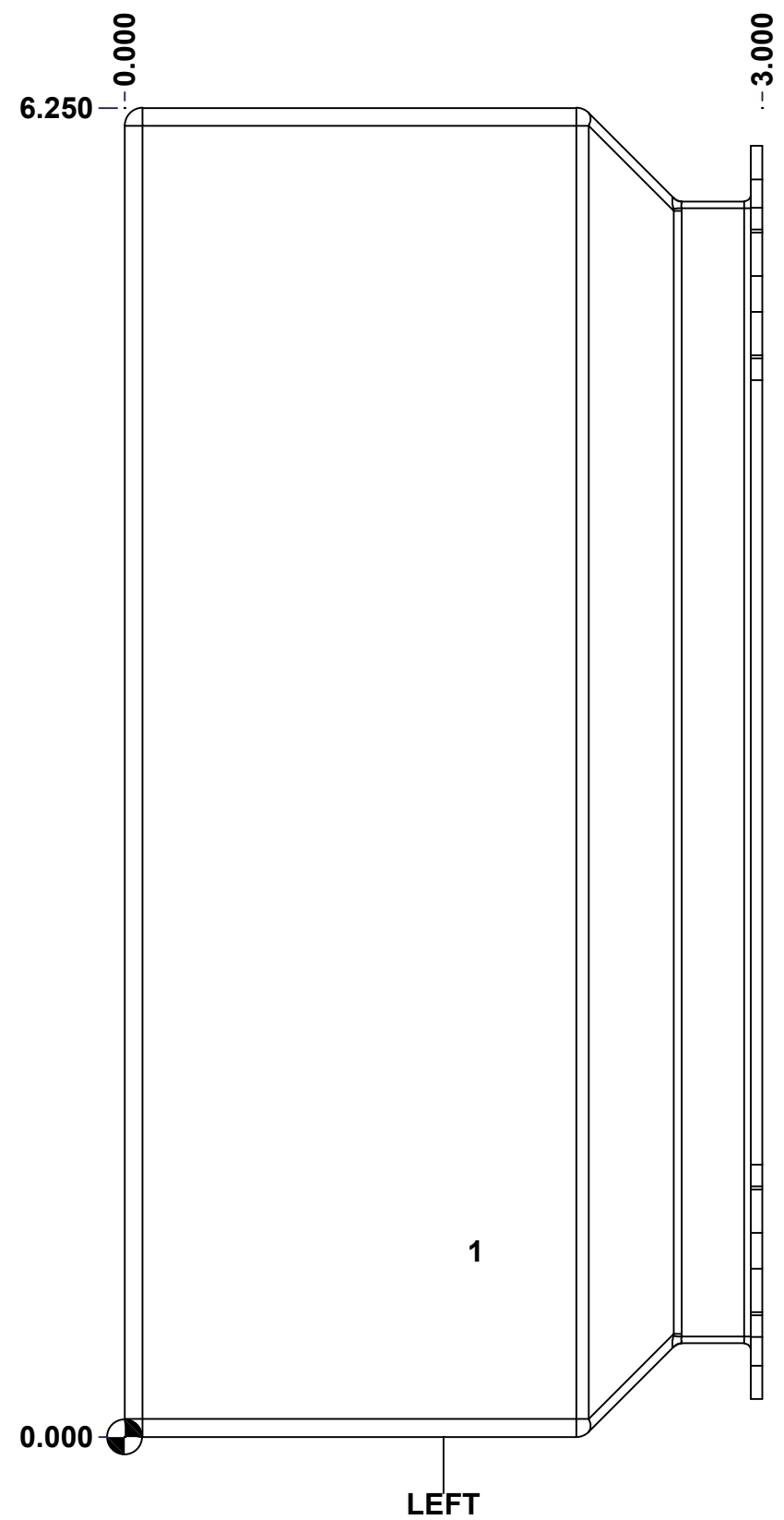

	Description	Status	
	1412SDSSMN 6.25" x 3.5" x 3" Body	(NULL)	
	Part Number Numéro Pièce	Rev.	
	1412SDSS050302MNB	0	4 9

This drawing is confidential and must not be reproduced or used without the consent of EXM

Ce dessin est confidentiel et ne doit pas être reproduit ou utilisé sans le consentement de EXM

STANDARD FEATURES ARE NOT LISTED IN THIS HOLE TABLE			
HOLE TABLE - BACK VIEW (CUSTOM FEATURE ONLY)			
CUT-OUT	XDIM	YDIM	DESCRIPTION
1	2.937	0.000	FOOT 885 ESCHMF2
2	0.563	0.000	FOOT 885 ESCHMF2
3	2.937	6.250	FOOT 885 ESCHMF2
4	2.937	6.250	FOOT 885 ESCHMF2
5	0.563	6.250	FOOT 885 ESCHMF2
6	2.937	0.000	FOOT 885 ESCHMF2
7	0.563	0.000	FOOT 885 ESCHMF2
8	2.937	6.250	FOOT 885 ESCHMF2
9	0.563	6.250	FOOT 885 ESCHMF2
10	0.563	6.250	FOOT 885 ESCHMF2
11	2.937	0.000	FOOT 885 ESCHMF2
12	0.563	0.000	FOOT 885 ESCHMF2
13	2.937	6.250	FOOT 885 ESCHMF2
14	0.563	6.250	FOOT 885 ESCHMF2
15	2.937	0.000	FOOT 885 ESCHMF2
16	0.563	0.000	FOOT 885 ESCHMF2
17	2.937	0.344	RIVET NUT M6_FH_CE (Inside)
18	0.563	0.344	RIVET NUT M6_FH_CE (Inside)
19	2.937	5.906	RIVET NUT M6_FH_CE (Inside)
20	2.937	5.906	RIVET NUT M6_FH_CE (Inside)
21	0.563	5.906	RIVET NUT M6_FH_CE (Inside)
22	2.937	0.344	RIVET NUT M6_FH_CE (Inside)
23	0.563	0.344	RIVET NUT M6_FH_CE (Inside)
24	2.937	5.906	RIVET NUT M6_FH_CE (Inside)
25	0.563	5.906	RIVET NUT M6_FH_CE (Inside)
26	0.563	5.906	RIVET NUT M6_FH_CE (Inside)
27	2.937	0.344	RIVET NUT M6_FH_CE (Inside)
28	0.563	0.344	RIVET NUT M6_FH_CE (Inside)
29	2.937	5.906	RIVET NUT M6_FH_CE (Inside)
30	0.563	5.906	RIVET NUT M6_FH_CE (Inside)
31	2.937	0.344	RIVET NUT M6_FH_CE (Inside)
32	0.563	0.344	RIVET NUT M6_FH_CE (Inside)

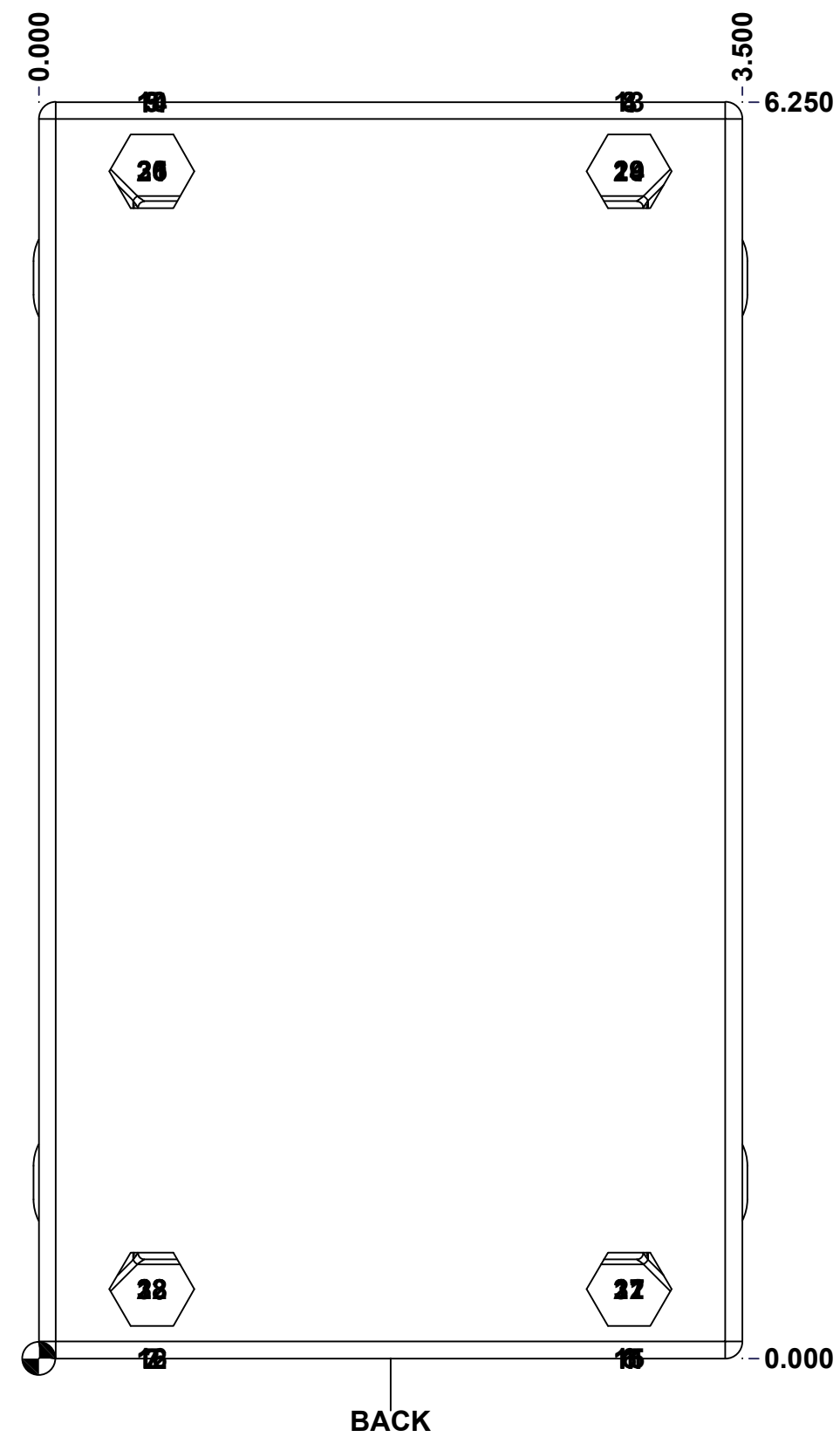

	Description	Status
	1412SDSSMN 6.25" x 3.5" x 3" Body	(NULL)
	Part Number	Rev.
	Numéro Pièce	5
	1412SDSS050302MNB	0
		9

This drawing is confidential and must not be reproduced or used without the consent of EXM

Ce dessin est confidentiel et ne doit pas être reproduit ou utilisé sans le consentement de EXM

No.	Revisions	Date	By/Par

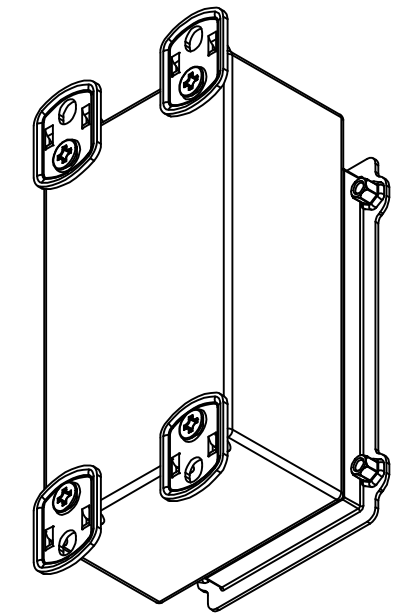

Isometric View

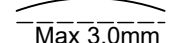

 Tél: (450) 979-4373 Fax: (450) 979-4626 www.exmweb.com		Flatness Aplatissement  Max 3.0mm
Customer Client Drawn By / Dessiné Par: BoxCad: BoxCad		Projection 
Material / Matière: 16 Ga Stainless Steel 304 (1.4mm)		Date: 06-Apr-23
Color / Couleur: Unpainted		Finish / Fini: Brushed
Description: 1412SDSSMN 6.25" x 3.5" x 3" Body		Detail Rev.
Part Number / Numéro Pièce: 1412SDSS050302MNB		Rev. 0

Qty	Part Number	Rev	Description
16	RIVET_NUT_SS_M6_FH_CE	0	Stainless Steel Rivet Nut M6 (Low Profile Close End)
16	STK-Q-03075	2	M6 x 16mm Stainless Steel Phillips Flat Head Screw
1	STK-Q-08500	4	Stainless Steel Standoff M6 x 10mm
1	1412SDSS050302MNB-P	0	1412SDSSMN 6.25" x 3.5" x 3" Body Part
16	885 ESCHMF2	4	885 ESCHMF2 Mounting Foot
4	RIVET_NUT_SS_M5_FH_OE	0	Stainless Steel Rivet Nut M5 (Low Profile Open End)
Parts List			

This drawing is confidential and must not be reproduced or used without the consent of EXM

Ce dessin est confidentiel et ne doit pas être reproduit ou utilisé sans le consentement de EXM

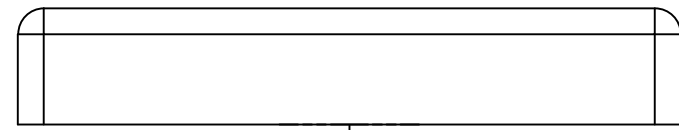

TOP

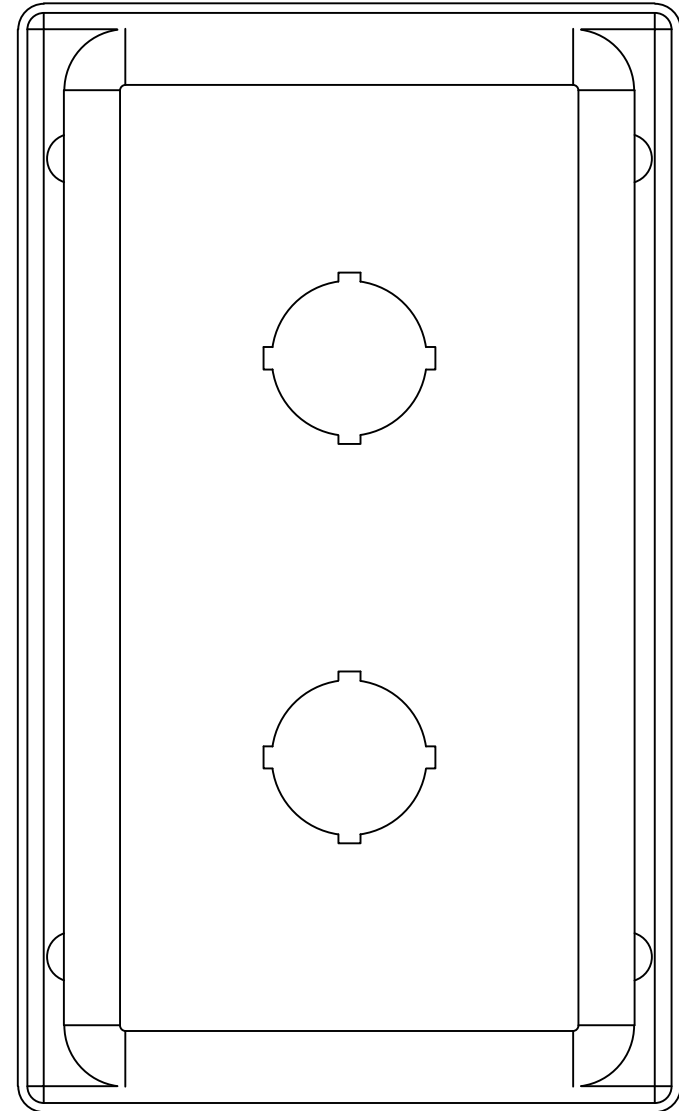

BACK

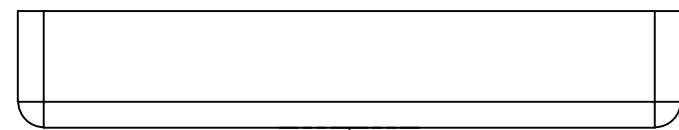

BOTTOM

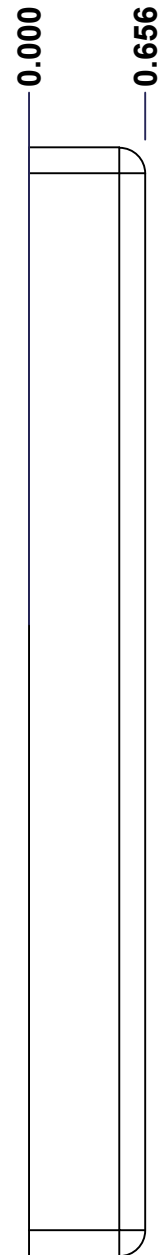

LEFT

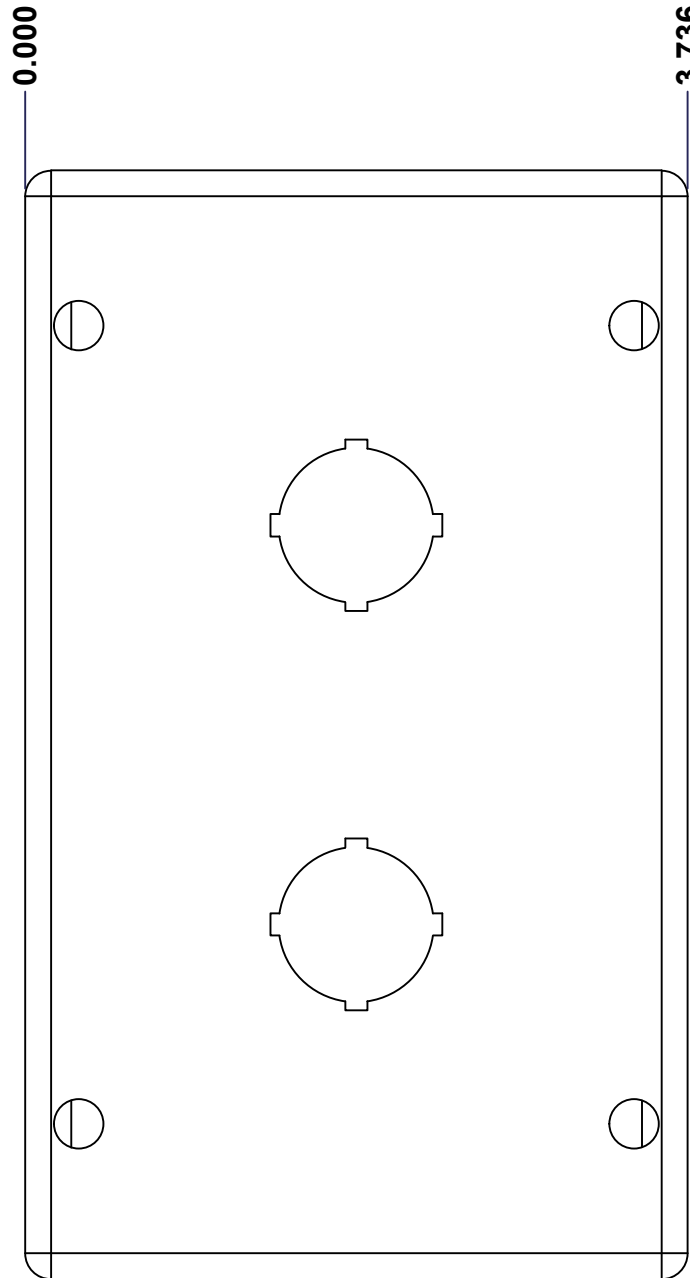

FRONT

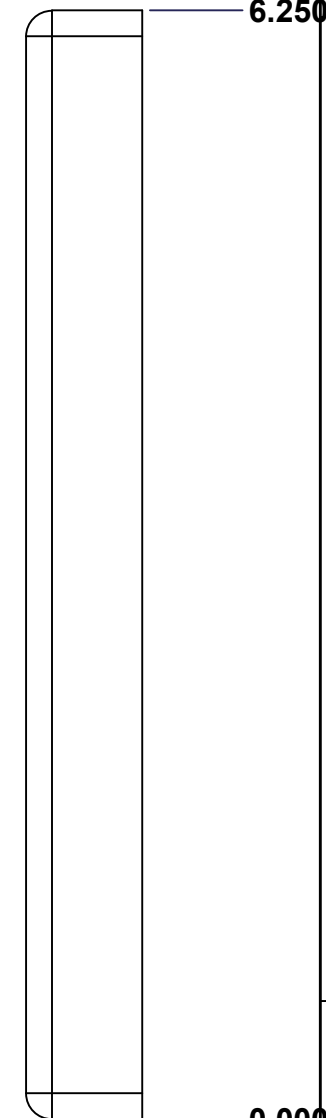

RIGHT

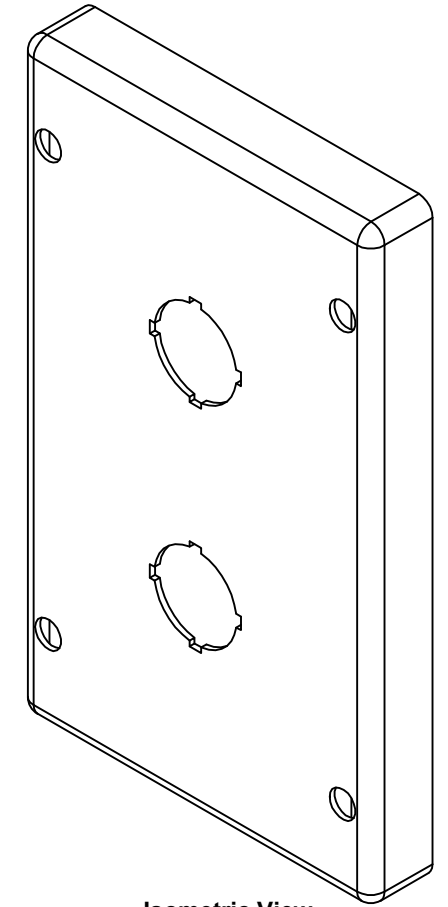

Isometric View

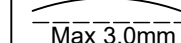
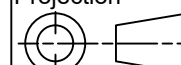

No.	Revisions	Date	By/Par

 Tél: (450) 979-4373 Fax: (450) 979-4626 www.exmweb.com		Flatness Aplatissement  Max 3.0mm Projection 
Customer Client	Date	
Drawn By Dessiné Par	BoxCad: BoxCad	Date 06-Apr-23
Material Matière	16 Ga Stainless Steel 304 (1.4mm)	
Color Couleur	Unpainted	Finish Fini Brushed
Description	Detail Rev.	
1412SDSSMN 6.25" x 3.5" Cover		
Part Number Numéro Pièce	Rev.	7
1412SDSS050302MNC	0	9

SEE BILL OF MATERIAL ON LAST PAGE

This drawing is confidential and must not be reproduced or used without the consent of EXM

Ce dessin est confidentiel et ne doit pas être reproduit ou utilisé sans le consentement de EXM

STANDARD FEATURES ARE NOT LISTED IN THIS HOLE TABLE			
HOLE TABLE - FRONT VIEW (CUSTOM FEATURE ONLY)			
CUT-OUT	XDIM	YDIM	DESCRIPTION
1	1.868	2.000	22.5 mm Miniature Pushbutton
2	1.868	4.250	22.5 mm Miniature Pushbutton

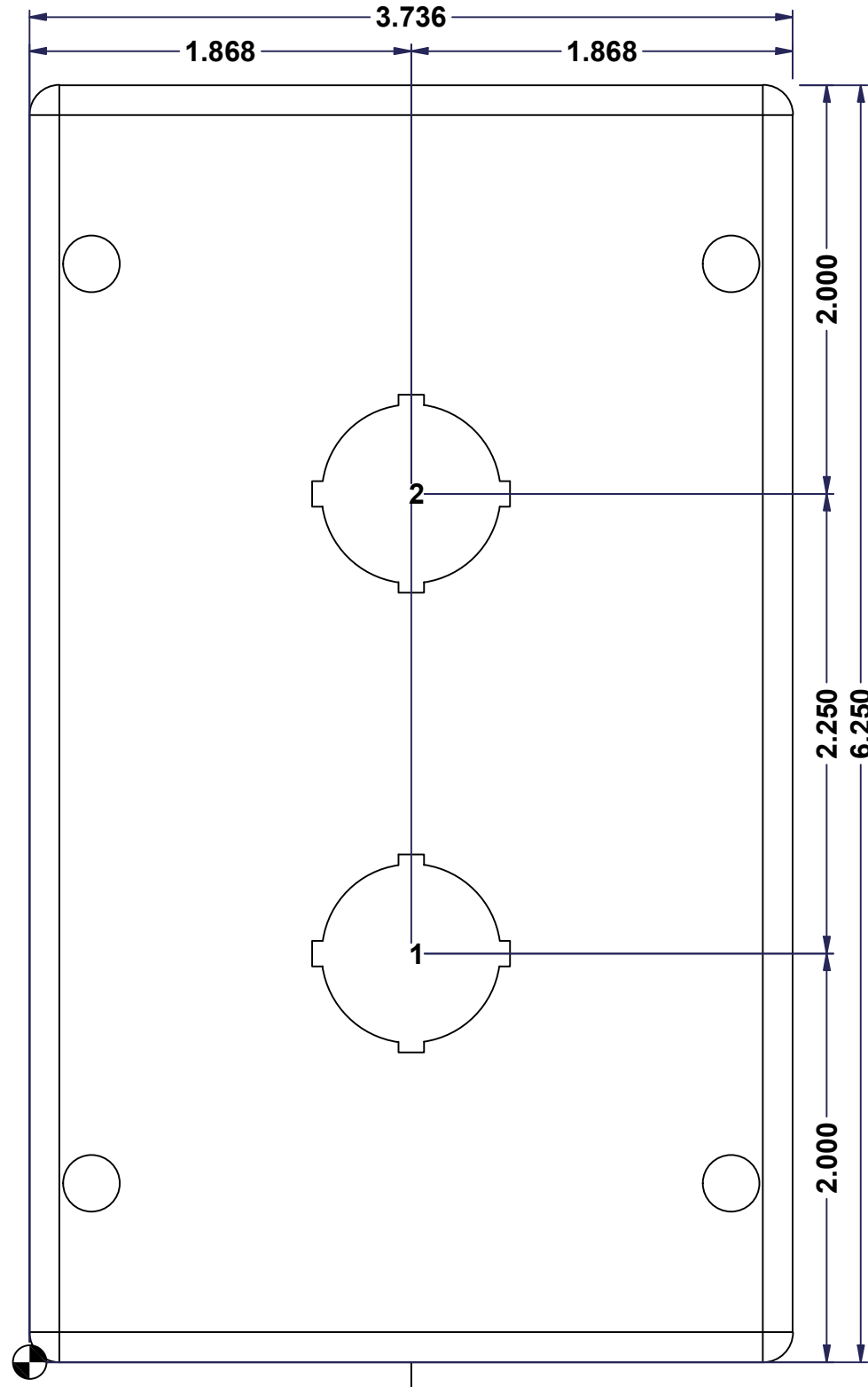

FRONT

	Description	Status
	1412SDSSMN 6.25" x 3.5" Cover	(NULL)
	Part Number	Rev.
	Numéro Pièce	8
	1412SDSS050302MNC	0
		9

This drawing is confidential and must not be reproduced or used without the consent of EXM

Ce dessin est confidentiel et ne doit pas être reproduit ou utilisé sans le consentement de EXM

No.	Revisions	Date	By/Par

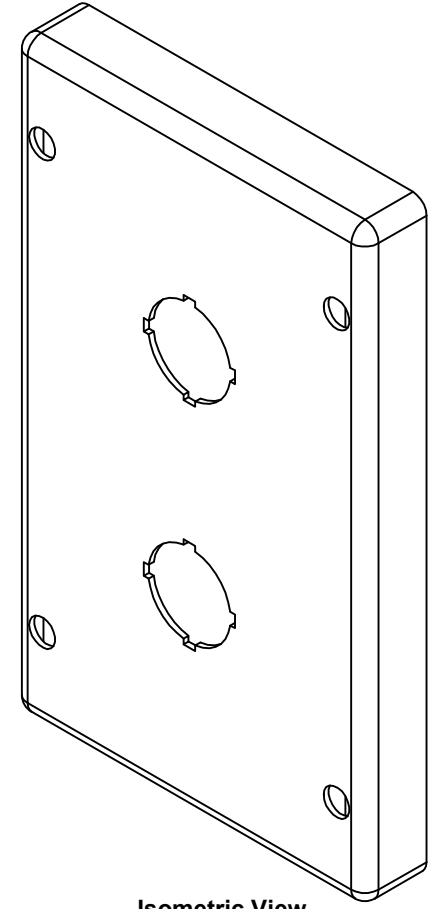

Isometric View



Tél: (450) 979-4373
 Fax: (450) 979-4626
www.exmweb.com

Flatness
Aplatissement
Max 3.0mm
Projection

Customer Client	Date
Drawn By / Dessiné Par: BoxCad: BoxCad	Date: 06-Apr-23
Material / Matière: 16 Ga Stainless Steel 304 (1.4mm)	

Color / Couleur: Unpainted	Finish / Fini: Brushed
----------------------------	------------------------

Description: 1412SDSSMN 6.25" x 3.5" Cover	Detail Rev.
--	-------------

Qty	Part Number	Rev	Description
1	1412SDSS050302MNG	0	1412SDSS 6.25" x 3.5" Gasket
1	1412SDSS050302MNC-P	0	1412SDSSMN 6.25" x 3.5" Cover Part
Parts List			

Part Number / Numéro Pièce: 1412SDSS050302MNC	Rev. 0	9
--	---------------	---