

This drawing is confidential and must not be reproduced or used without the consent of EXM

Ce dessin est confidentiel et ne doit pas être reproduit ou utilisé sans le consentement de EXM

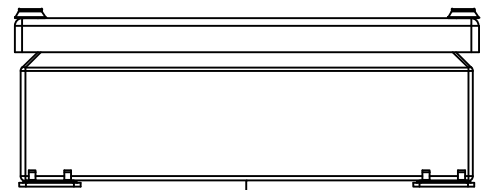

TOP

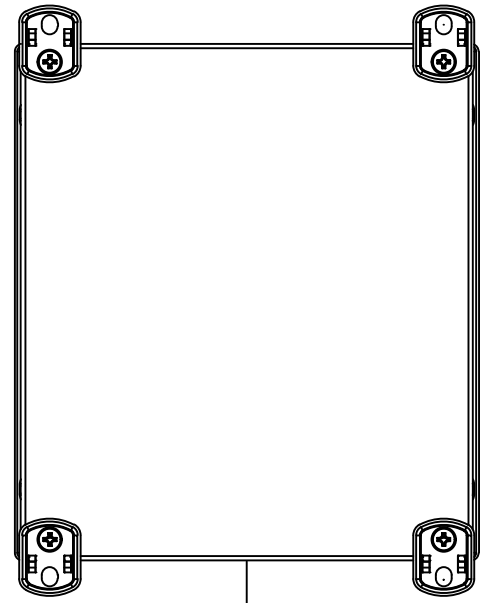

BACK

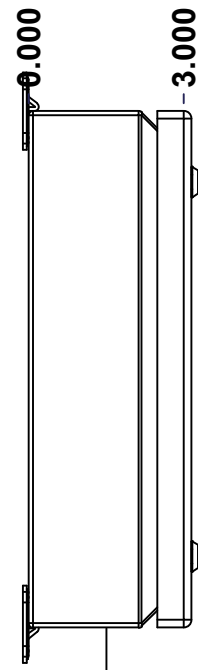

LEFT

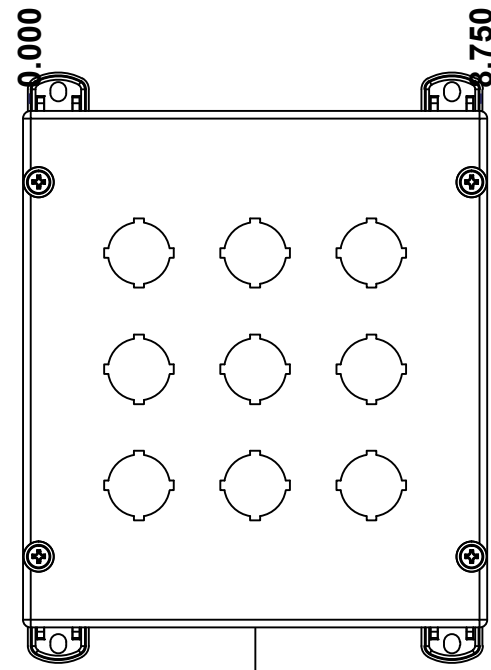

FRONT

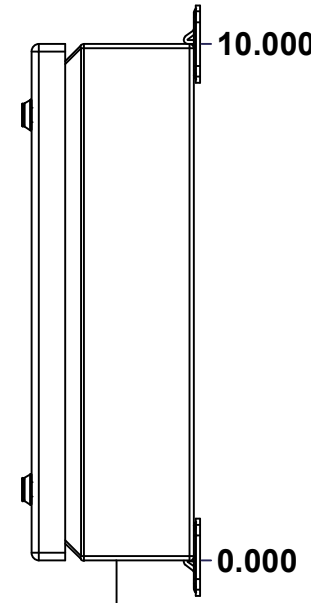

RIGHT

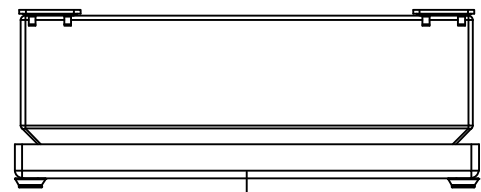

BOTTOM

No.	Revisions	Date	By/Par

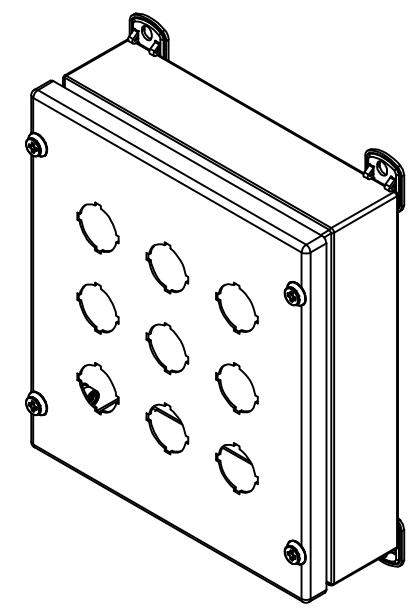

Isometric View



 Tél: (450) 979-4373 Fax: (450) 979-4626 www.exmweb.com		Flatness Aplatissement
		Max 3.0mm
Customer Client		Date
Drawn By Dessiné Par BoxCad: BoxCad		Date 04-Sep-25
Material Matière 16 Ga Stainless Steel 304 (1.4mm)		
Color Couleur Asa-61 Grey	Finish Fini Smooth	
Description 1412SDSS 10" x 8.75" x 3" Assembly		Detail Rev.
Part Number Numéro Pièce 1412SDSS090803P		Rev. 1 0

SEE BILL OF MATERIAL ON LAST PAGE

This drawing is confidential and must not be reproduced or used without the consent of EXM

Ce dessin est confidentiel et ne doit pas être reproduit ou utilisé sans le consentement de EXM

NOTE	
ITEM	DESCRIPTION
1	NEMA 4X Enclosure (IP66)
2	C/W Standard ground standoffs on box and cover
3	W/O Standard door stiffener
4	W/O Inner panel
5	W/O Inner panel mounting standoffs
6	C/W 885 ESCHMF2 Mounting Feet (Installed)

No.	Revisions	Date	By/Par

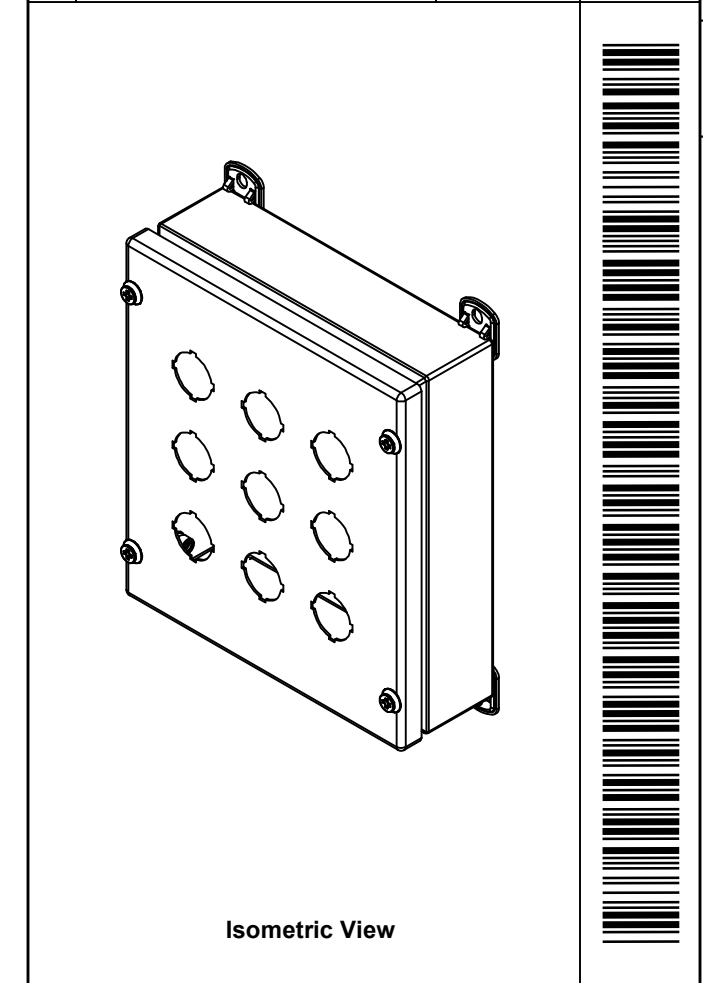

	Tél: (450) 979-4373 Fax: (450) 979-4626 www.exmweb.com	Flatness Aplatissement Max 3.0mm Projection
	Customer Client	Date
Drawn By Dessiné Par	BoxCad: BoxCad	Date 04-Sep-25
Material Matière 16 Ga Stainless Steel 304 (1.4mm)		
Color Couleur Asa-61 Grey	Finish Fini Smooth	Description 1412SDSS 10" x 8.75" x 3" Assembly
Part Number Numéro Pièce 1412SDSS090803P		Rev. 2 0 / 9

PACKING		
ITEM	QTY	DESCRIPTION
Cardboard sleeve	2	Top and Bottom
Cardboard strip	2	Between back of enclosure and inner panel
Plastic bag	1	To protect cover surface and inside gasket
Plastic strap - Black	2	To Squeeze the 2 cardboard sleeve together
Packaging label	1	White label with product number

Qty	Part Number	Rev	Description
1	1412SDSS090803PC	0	1412SDSS 10" x 8.75" Cover
1	STK-K-02925	3	5412 ESSSC Accessory Kit
1	885 ESSCHMFQ	0	5412 ESSCH Mounting Feet Accessory Kit
1	1412SDSS090803PB	0	1412SDSS 10" x 8.75" x 3" Body
Parts List			

This drawing is confidential and must not be reproduced or used without the consent of EXM

Ce dessin est confidentiel et ne doit pas être reproduit ou utilisé sans le consentement de EXM

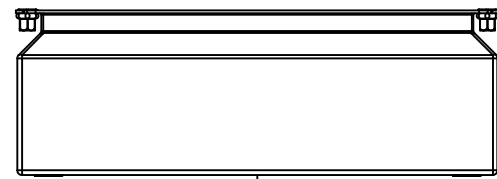

TOP

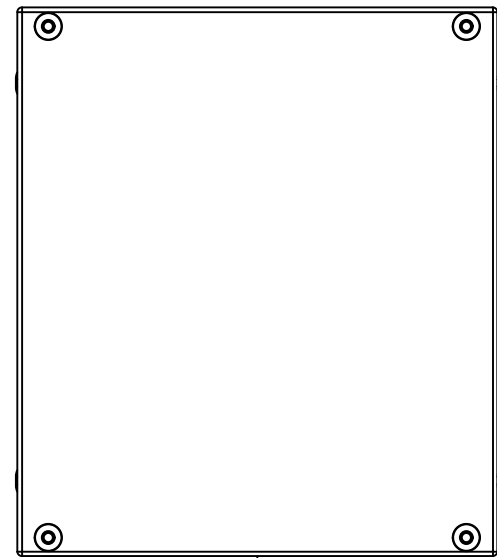

BACK

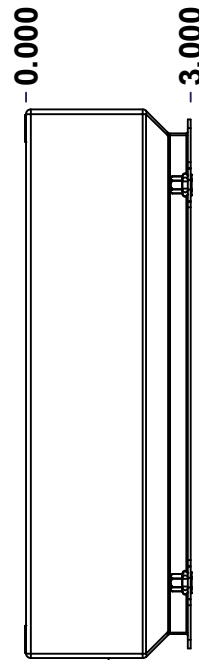

LEFT

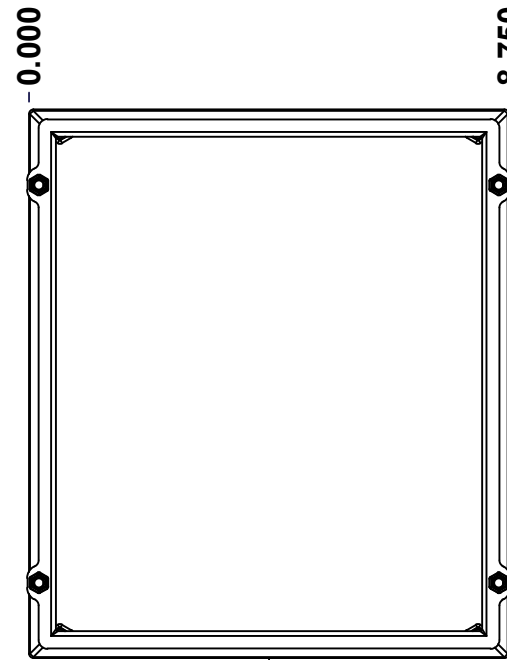

FRONT

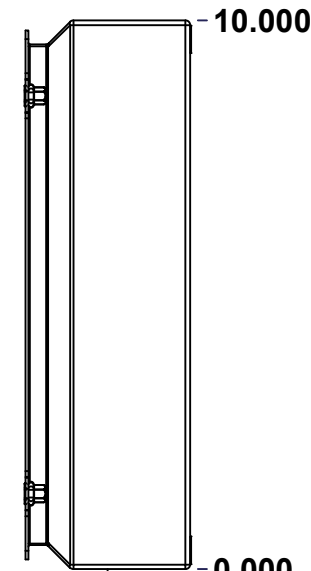

RIGHT

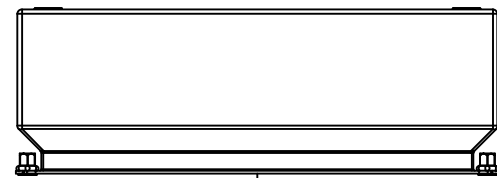

BOTTOM

No.	Revisions	Date	By/Par

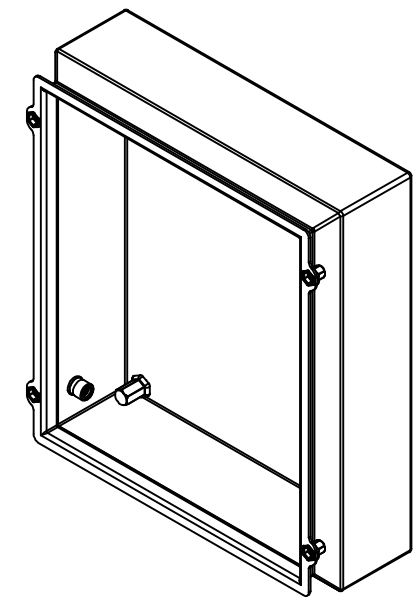

Isometric View



Tél: (450) 979-4373
 Fax: (450) 979-4626
www.exmweb.com

Flatness
Aplatissement

Max 3.0mm

Projection



Customer Client	Date
Drawn By / Dessiné Par: BoxCad: BoxCad	Date: 04-Sep-25
Material / Matière: 16 Ga Stainless Steel 304 (1.4mm)	
Color / Couleur: Asa-61 Grey	Finish / Fini: Smooth
Description: 1412SDSS 10" x 8.75" x 3" Body	Detail Rev.
Part Number / Numéro Pièce: 1412SDSS090803PB	Rev. 3
SEE BILL OF MATERIAL ON LAST PAGE	0

This drawing is confidential and must not be reproduced or used without the consent of EXM

Ce dessin est confidentiel et ne doit pas être reproduit ou utilisé sans le consentement de EXM

STANDARD FEATURES ARE NOT LISTED IN THIS HOLE TABLE			
HOLE TABLE - LEFT VIEW (CUSTOM FEATURE ONLY)			
CUT-OUT	XDIM	YDIM	DESCRIPTION
1	1.625	0.875	STANDOFF M6 x 10mm (Inside)

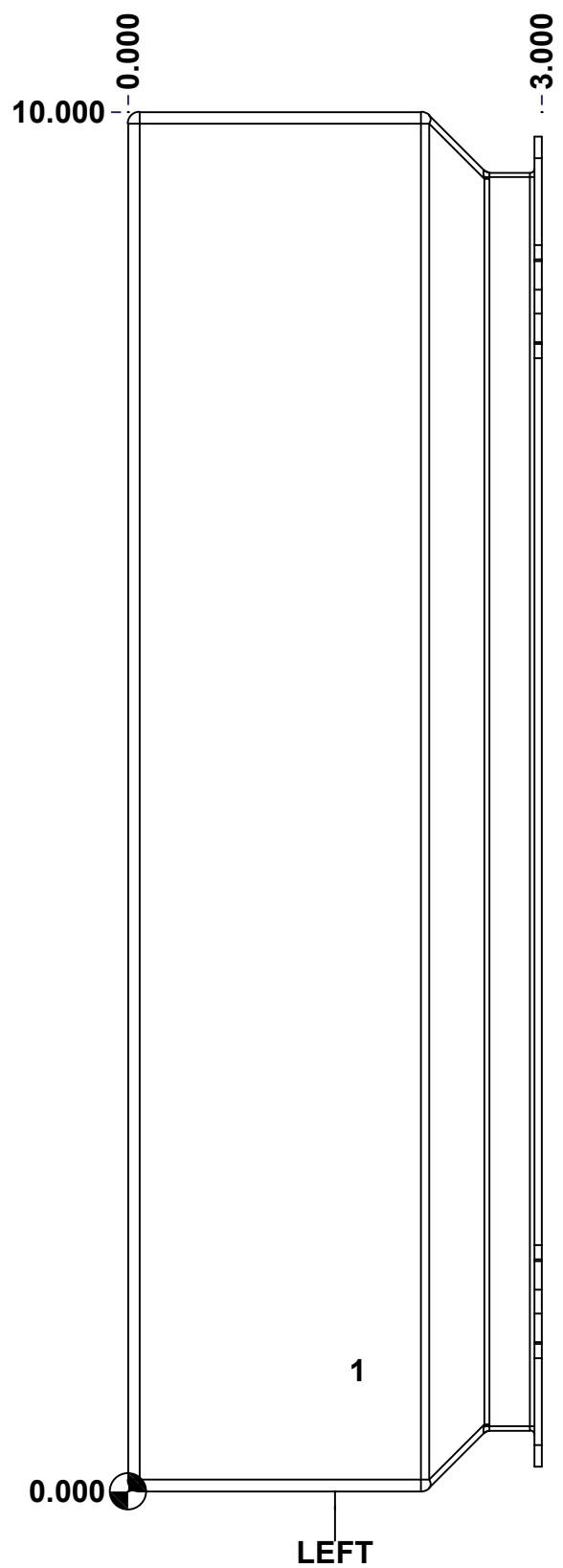

	Description	Status	
	1412SDSS 10" x 8.75" x 3" Body	(NULL)	
	Part Number Numéro Pièce	Rev.	
	1412SDSS090803PB	0	4 9

This drawing is confidential and must not be reproduced or used without the consent of EXM

Ce dessin est confidentiel et ne doit pas être reproduit ou utilisé sans le consentement de EXM

STANDARD FEATURES ARE NOT LISTED IN THIS HOLE TABLE

HOLE TABLE - BACK VIEW (CUSTOM FEATURE ONLY)

CUT-OUT	XDIM	YDIM	DESCRIPTION
1	8.187	0.000	FOOT 885 ESCHMF2
2	0.563	0.000	FOOT 885 ESCHMF2
3	8.187	10.000	FOOT 885 ESCHMF2
4	0.563	10.000	FOOT 885 ESCHMF2
5	8.187	0.344	RIVET NUT M6_FH_CE (Inside)
6	0.563	0.344	RIVET NUT M6_FH_CE (Inside)
7	8.187	9.656	RIVET NUT M6_FH_CE (Inside)
8	0.563	9.656	RIVET NUT M6_FH_CE (Inside)

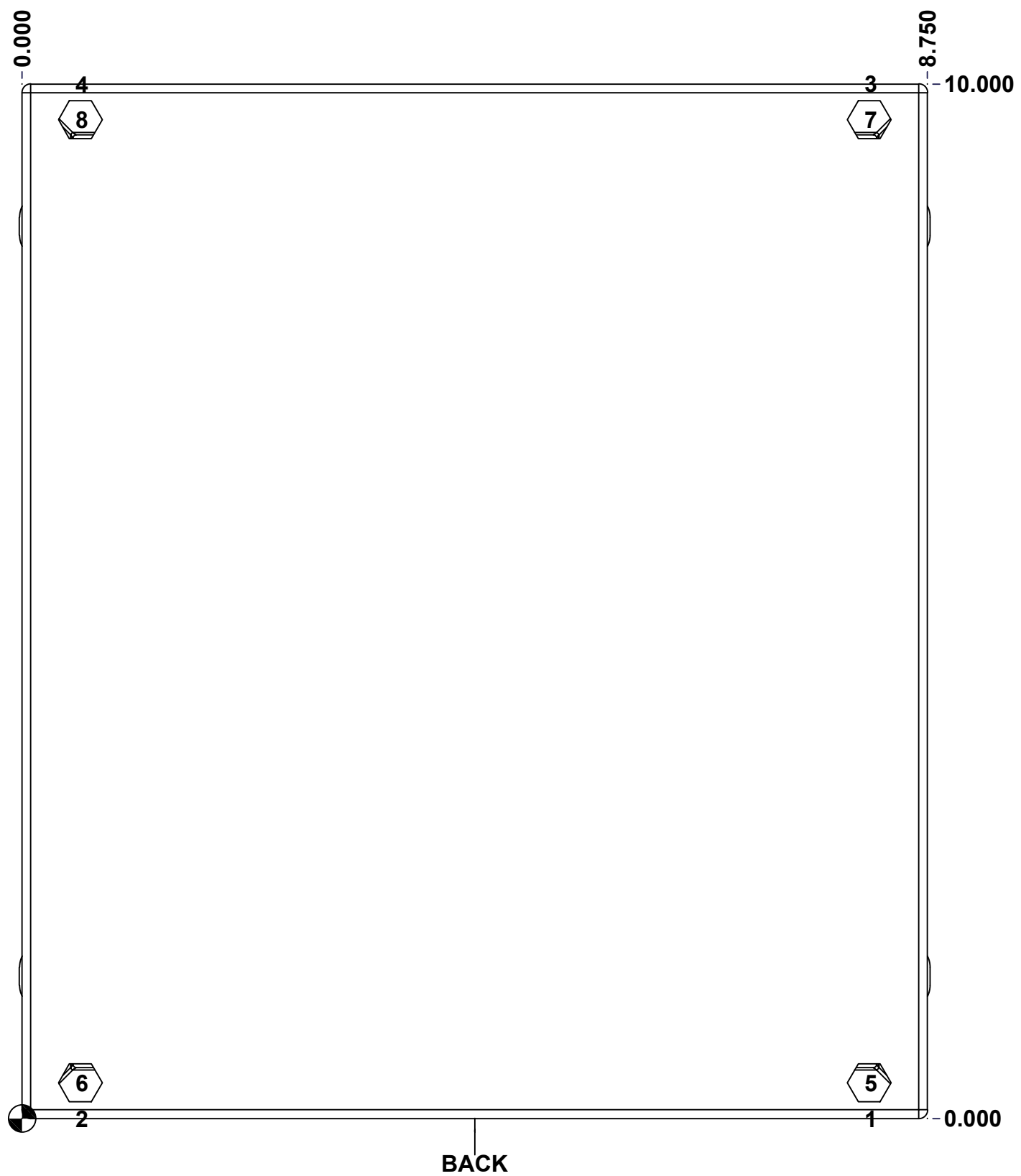

	Description	Status	
	1412SDSS 10" x 8.75" x 3" Body	(NULL)	
	Part Number Numéro Pièce	Rev.	
	1412SDSS090803PB	0	5/9

This drawing is confidential and must not be reproduced or used without the consent of EXM

Ce dessin est confidentiel et ne doit pas être reproduit ou utilisé sans le consentement de EXM

No.	Revisions	Date	By/Par

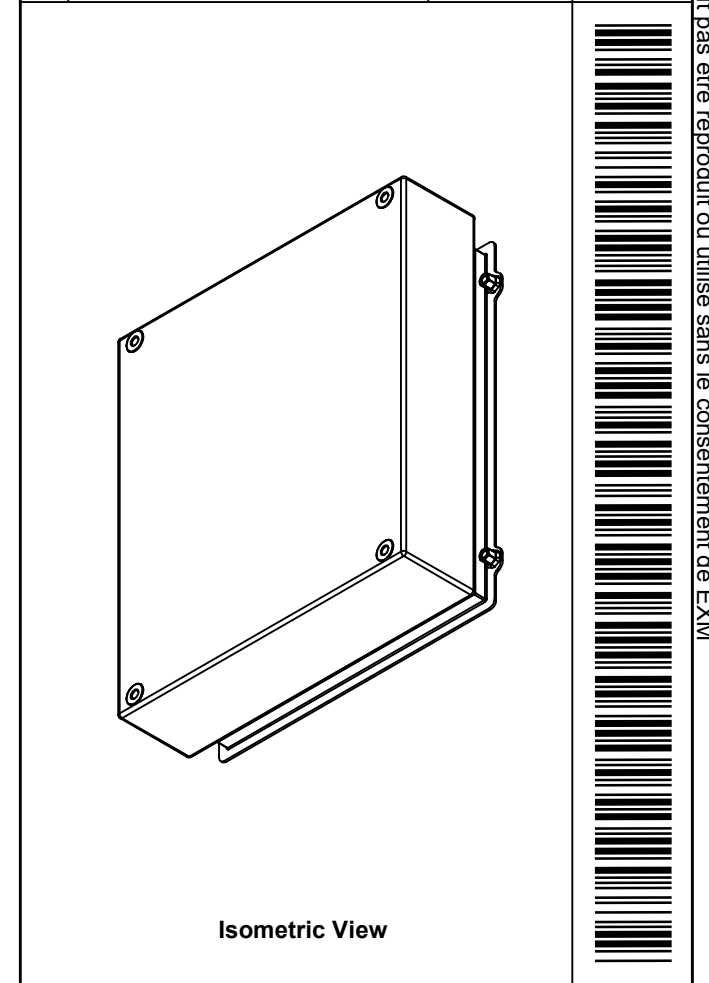

Tél: (450) 979-4373 Fax: (450) 979-4626 www.exmweb.com		Flatness Aplatissement	
		Max 3.0mm	
Customer Client		Date	
		Date 04-Sep-25	
Drawn By Dessiné Par		BoxCad: BoxCad	
Material Matière			
16 Ga Stainless Steel 304 (1.4mm)			
Color Couleur		Finish Fini	
Asa-61 Grey		Smooth	
Description			Detail Rev.
1412SDSS 10" x 8.75" x 3" Body			
Part Number Numéro Pièce		Rev.	6
1412SDSS090803PB		0	9

Qty	Part Number	Rev	Description
4	RIVET_NUT_SS_M6_FH_CE	0	Stainless Steel Rivet Nut M6 (Low Profile Close End)
1	STK-P-02400S	0	Powder Paint (Asa-61 Grey / Smooth)
1	1412SDSS090803PB-P	0	1412SDSS 10" x 8.75" x 3" Body Part
1	STK-Q-08500	4	Stainless Steel Standoff M6 x 10mm
4	RIVET_NUT_SS_M5_FH_OE	0	Stainless Steel Rivet Nut M5 (Low Profile Open End)
Parts List			

This drawing is confidential and must not be reproduced or used without the consent of EXM

Ce dessin est confidentiel et ne doit pas être reproduit ou utilisé sans le consentement de EXM

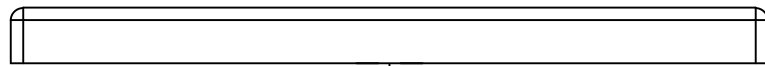

TOP

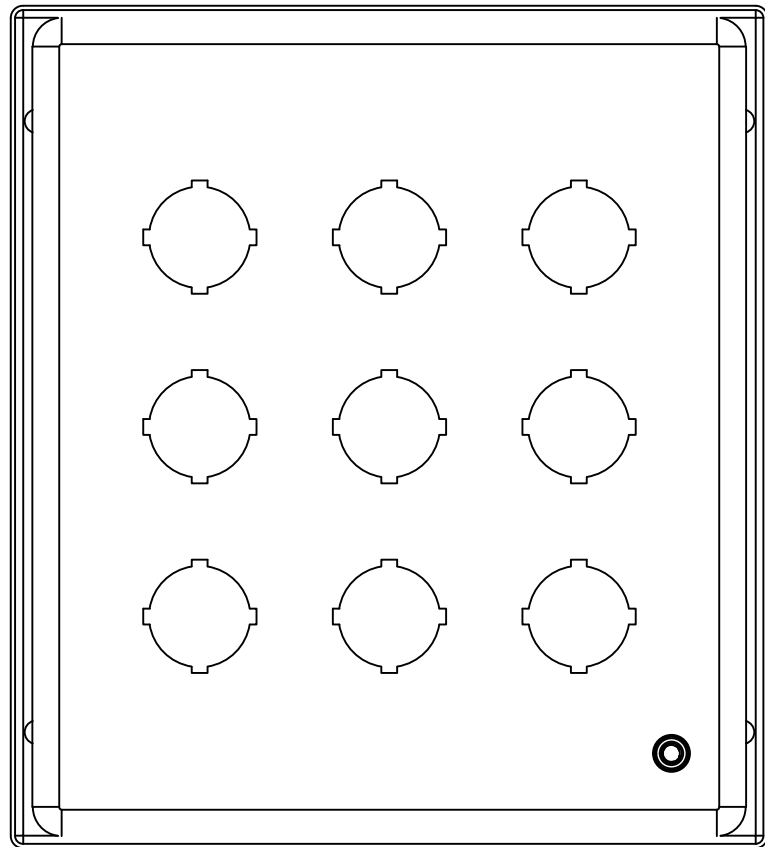

BACK

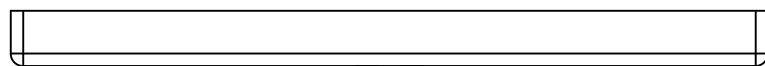

BOTTOM

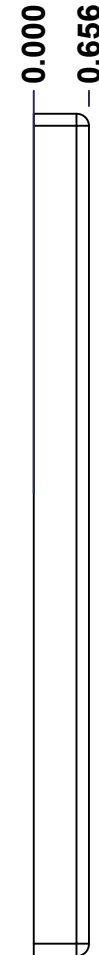

LEFT

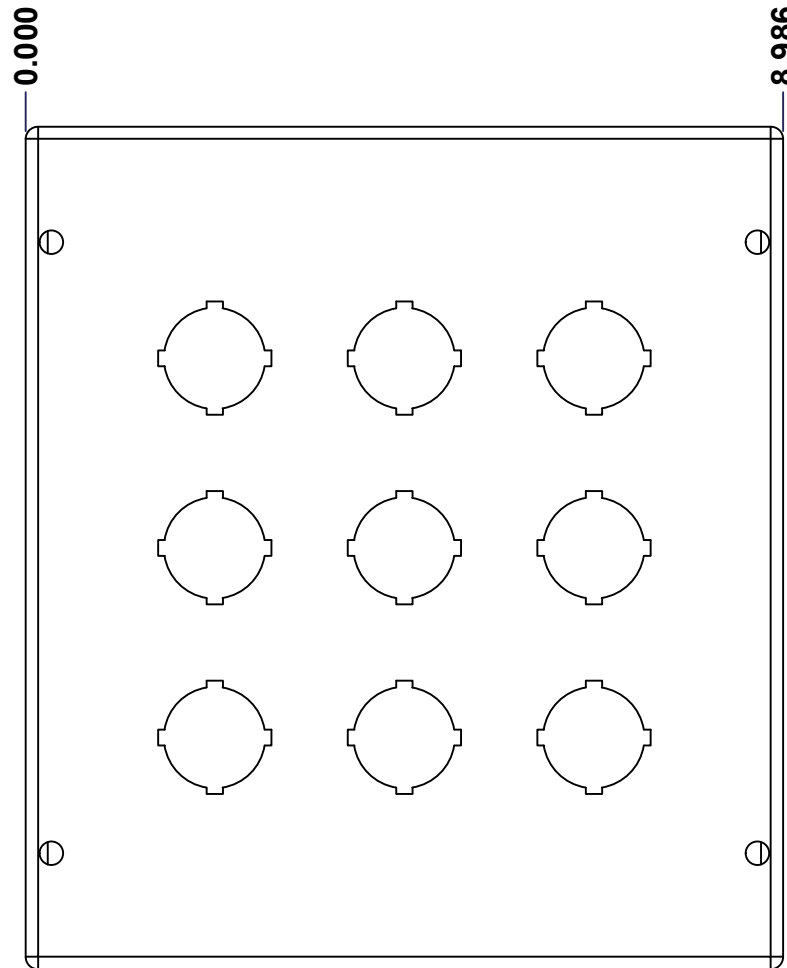

FRONT

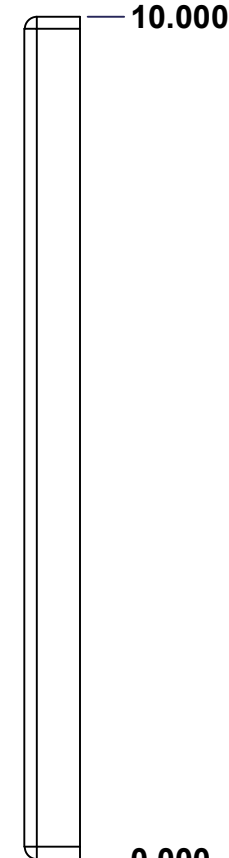

RIGHT

No.	Revisions	Date	By/Par

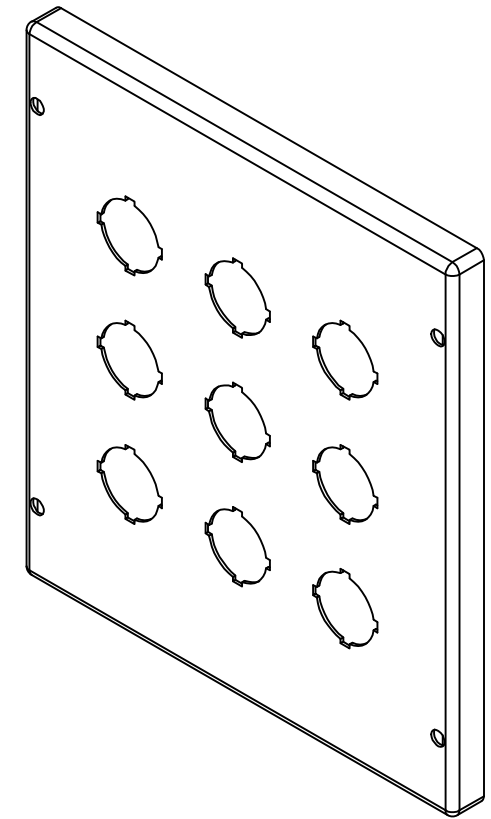

Isometric View



Tél: (450) 979-4373
 Fax: (450) 979-4626
www.exmweb.com

Flatness
Aplatissement

Max 3.0mm

Projection

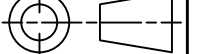

Customer Client	Date
Drawn By Dessiné Par BoxCad: BoxCad	Date 04-Sep-25
Material Matière 16 Ga Stainless Steel 304 (1.4mm)	
Color Couleur Asa-61 Grey	Finish Fini Smooth
Description 1412SDSS 10" x 8.75" Cover	Detail Rev.
Part Number Numéro Pièce 1412SDSS090803PC	Rev. 0

SEE BILL OF MATERIAL ON LAST PAGE

This drawing is confidential and must not be reproduced or used without the consent of EXM

Ce dessin est confidentiel et ne doit pas être reproduit ou utilisé sans le consentement de EXM

STANDARD FEATURES ARE NOT LISTED IN THIS HOLE TABLE

HOLE TABLE - FRONT VIEW (CUSTOM FEATURE ONLY)

CUT-OUT	XDIM	YDIM	DESCRIPTION
1	6.743	2.750	30.5 mm Standard Pushbutton
2	6.743	5.000	30.5 mm Standard Pushbutton
3	6.743	7.250	30.5 mm Standard Pushbutton
4	4.493	2.750	30.5 mm Standard Pushbutton
5	4.493	5.000	30.5 mm Standard Pushbutton
6	4.493	7.250	30.5 mm Standard Pushbutton
7	2.243	2.750	30.5 mm Standard Pushbutton
8	2.243	5.000	30.5 mm Standard Pushbutton
9	2.243	7.250	30.5 mm Standard Pushbutton
10	1.145	1.125	STANDOFF M6 x 10mm (Inside)

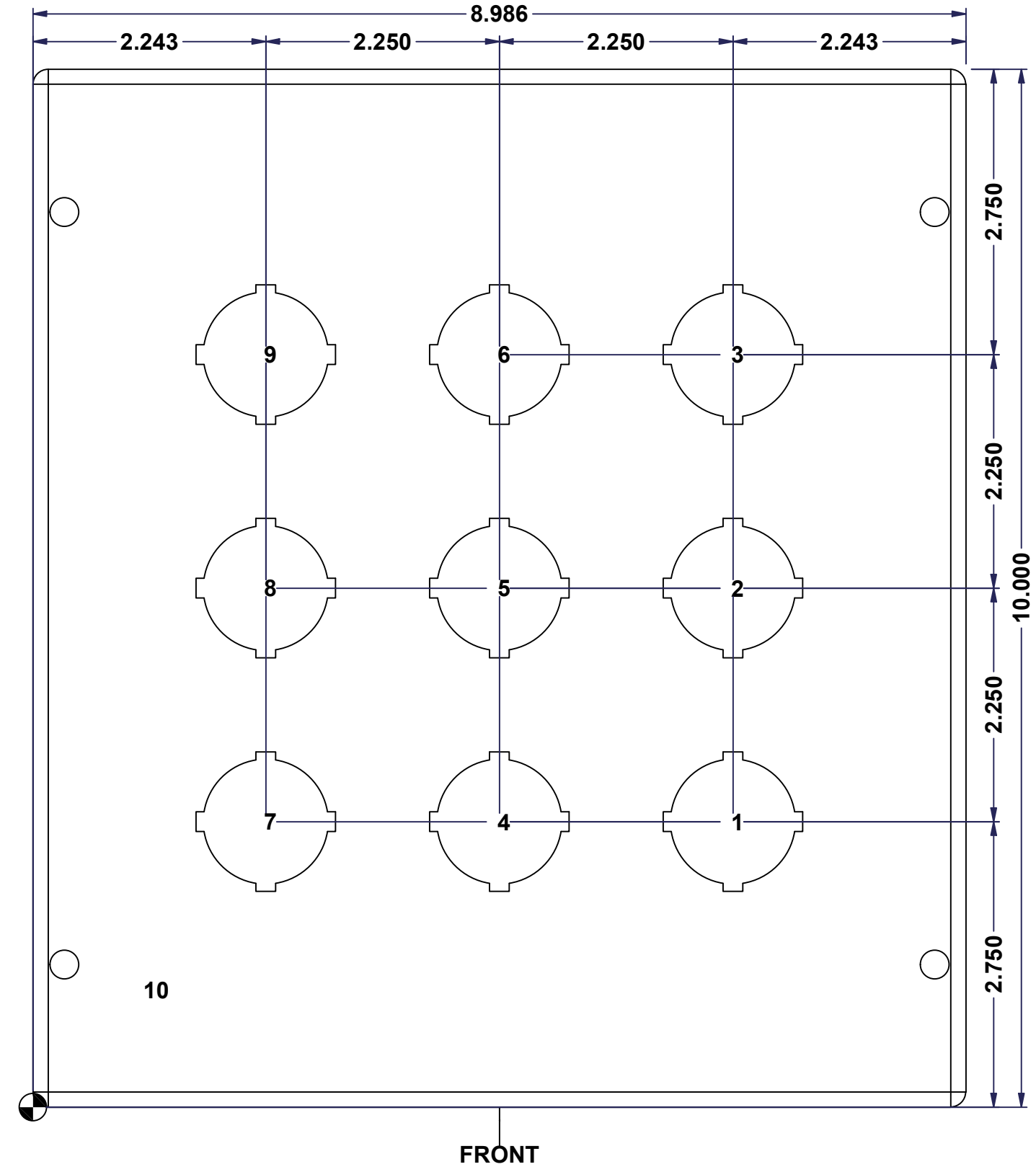

	Description	Status
	1412SDSS 10" x 8.75" Cover	(NULL)
Part Number Numéro Pièce 1412SDSS090803PC	Rev.	8
	0	9

This drawing is confidential and must not be reproduced or used without the consent of EXM

Ce dessin est confidentiel et ne doit pas être reproduit ou utilisé sans le consentement de EXM

No.	Revisions	Date	By/Par

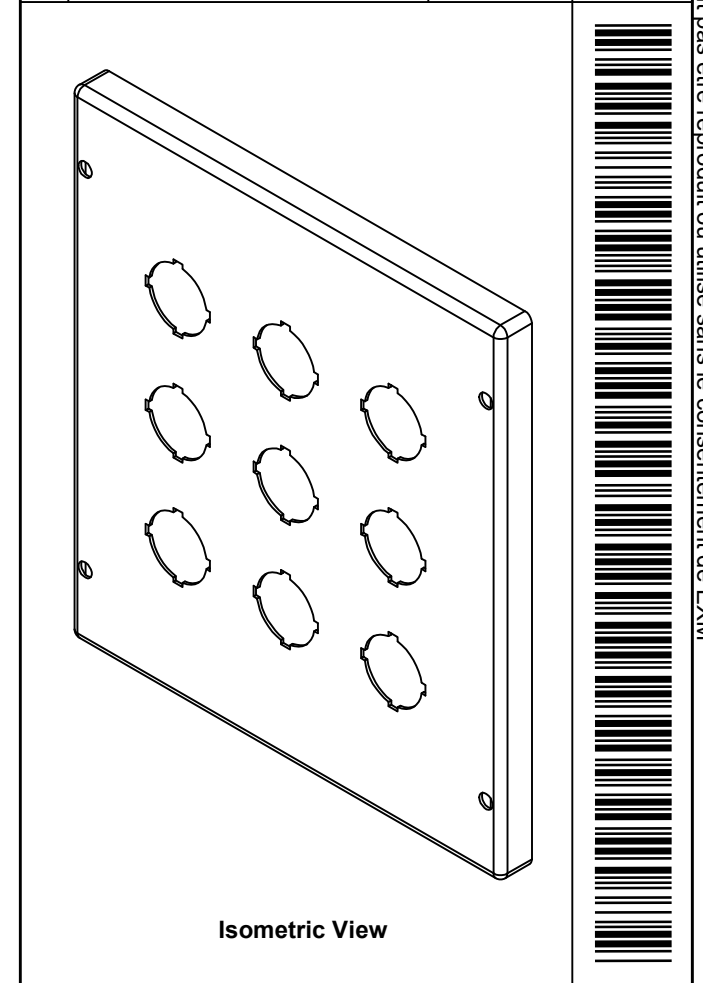

 Tél: (450) 979-4373 Fax: (450) 979-4626 www.exmweb.com		Flatness Aplatissement Max 3.0mm Projection 
Customer Client	Date	
Drawn By Dessiné Par	BoxCad: BoxCad	Date 04-Sep-25
Material Matière	16 Ga Stainless Steel 304 (1.4mm)	
Color Couleur	Asa-61 Grey	Finish Fini Smooth
Description		Detail Rev.
1412SDSS 10" x 8.75" Cover		
Part Number Numéro Pièce	Rev.	9
1412SDSS090803PC	0	9

Qty	Part Number	Rev	Description
1	STK-Q-08500	4	Stainless Steel Standoff M6 x 10mm
1	STK-P-02400S	0	Powder Paint (Asa-61 Grey / Smooth)
1	1412SDSS090803PG	0	1412SDSS 10" x 8.75" Gasket
1	1412SDSS090803PC-P	0	1412SDSS 10" x 8.75" Cover Part
Parts List			