

This drawing is confidential and must not be reproduced or used without the consent of EXM

Ce dessin est confidentiel et ne doit pas être reproduit ou utilisé sans le consentement de EXM

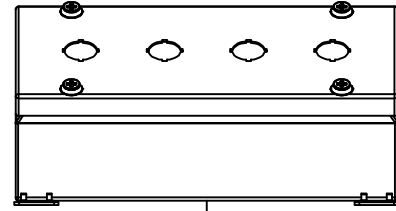

TOP

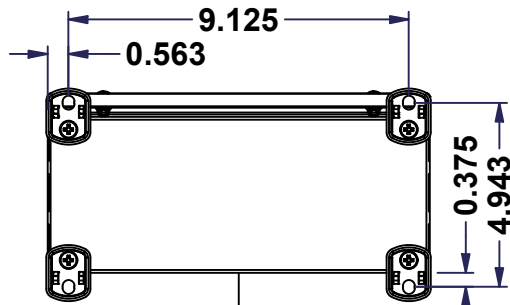

BACK

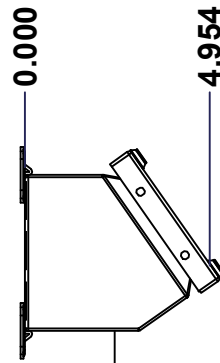

LEFT

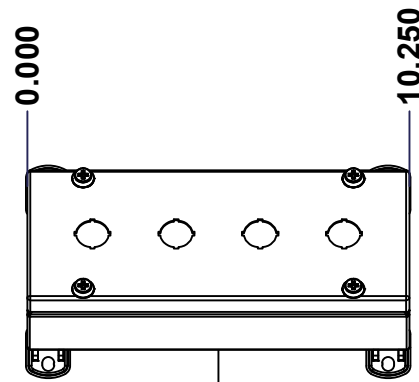

FRONT

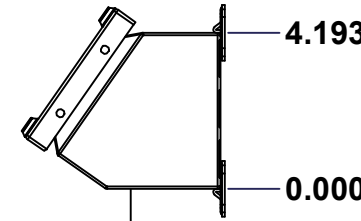

RIGHT

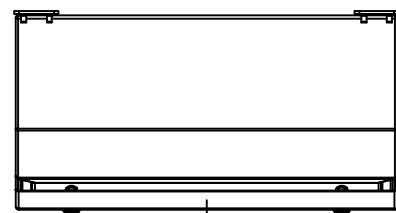

BOTTOM

No.	Revisions	Date	By/Par

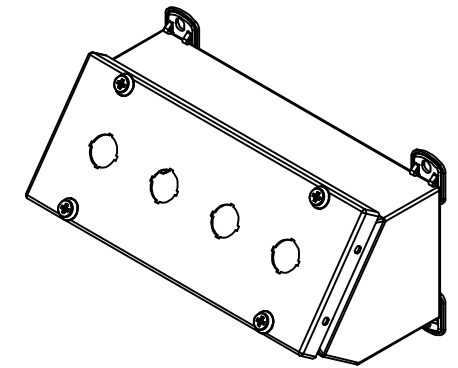

Isometric View



Tél: (450) 979-4373  
 Fax: (450) 979-4626  
[www.exmweb.com](http://www.exmweb.com)

Flatness  
Aplatissement

Max 3.0mm

Projection



Customer Client	Date
Drawn By / Dessiné Par: BoxCad: BoxCad	Date: 05-Sep-25
Material / Matière: 16 Ga Cold Rolled A1008 CS Type B (1.4mm)	
Color / Couleur: Asa-61 Grey	Finish / Fini: Smooth
Description: 1412SFMN 4" x 10.25" x 4.814" Assembly	
Part Number / Numéro Pièce: 1412SF031004MN	Detail Rev.:
Rev. 0	1 / 9

SEE BILL OF MATERIAL ON LAST PAGE

This drawing is confidential and must not be reproduced or used without the consent of EXM

Ce dessin est confidentiel et ne doit pas être reproduit ou utilisé sans le consentement de EXM

NOTE	
ITEM	DESCRIPTION
1	NEMA 4, 12 Enclosure (IP66)
2	C/W Standard ground standoffs on box only
3	W/O Standard door stiffener
4	W/O Inner panel
5	W/O Inner panel mounting standoffs
6	C/W 885 ESCHMF1 Mounting Feet (Installed)

No.	Revisions	Date	By/Par

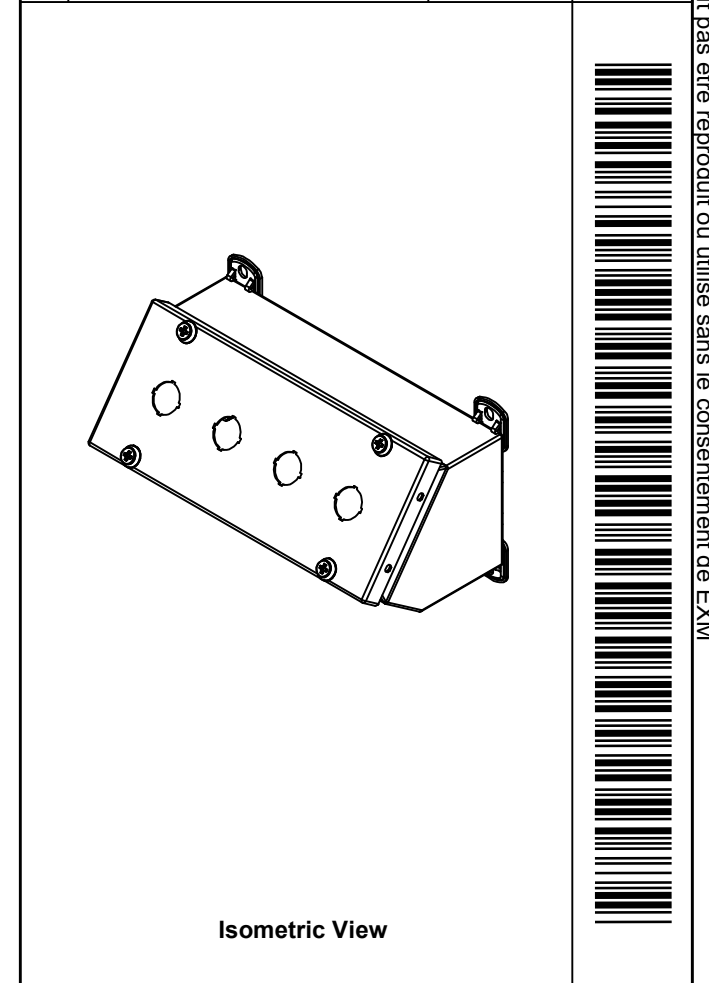



Tél: (450) 979-4373  
Fax: (450) 979-4626  
[www.exmweb.com](http://www.exmweb.com)

Flatness  
Aplatissement  
Max 3.0mm

Projection

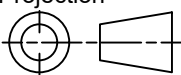

Customer Client	Date
Drawn By / Dessiné Par: BoxCad: BoxCad	Date: 05-Sep-25
Material / Matière: 16 Ga Cold Rolled A1008 CS Type B (1.4mm)	
Color / Couleur: Asa-61 Grey	Finish / Fini: Smooth

PACKING		
ITEM	QTY	DESCRIPTION
Cardboard sleeve	2	Top and Bottom
Cardboard strip	2	Between back of enclosure and inner panel
Plastic bag	1	To protect cover surface and inside gasket
Plastic strap - Black	2	To Squeeze the 2 cardboard sleeve together
Packaging label	1	White label with product number

1	885 ESSCHMFQ	0	5412 ESSCH Mounting Feet Accessory Kit
1	STK-K-02920	3	5412 ESSC Accessory Kit
1	1412SF031004MNC	0	1412SFMN 4" x 10.25" Cover
1	1412SF031004MNB	0	1412SFMN 4" x 10.25" x 4.814" Body
Qty	Part Number	Rev	Description
Parts List			

Description		Detail Rev.	
1412SFMN 4" x 10.25" x 4.814" Assembly			
Part Number / Numéro Pièce		Rev.	
<b>1412SF031004MN</b>		<b>0</b>	2 / 9

This drawing is confidential and must not be reproduced or used without the consent of EXM

Ce dessin est confidentiel et ne doit pas être reproduit ou utilisé sans le consentement de EXM

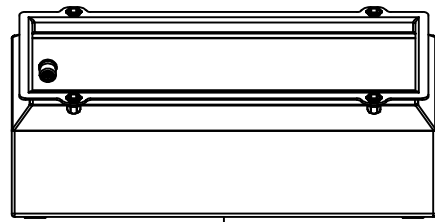

TOP

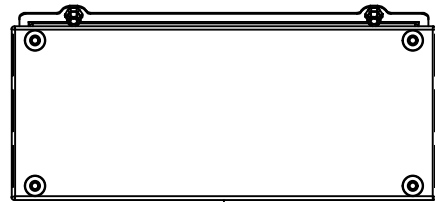

BACK

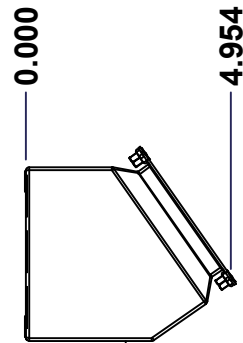

LEFT

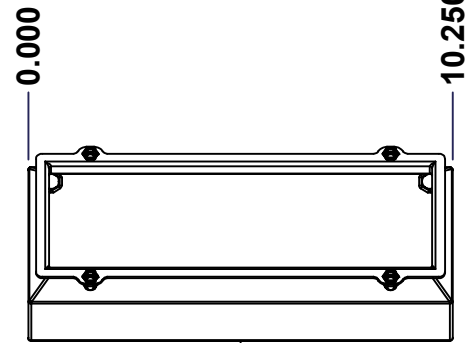

FRONT

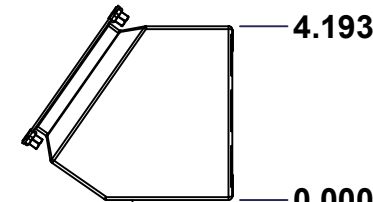

RIGHT

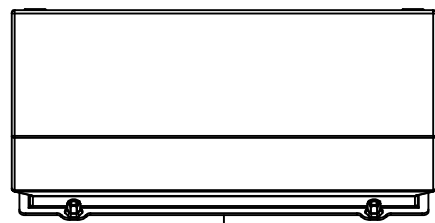

BOTTOM

No.	Revisions	Date	By/Par

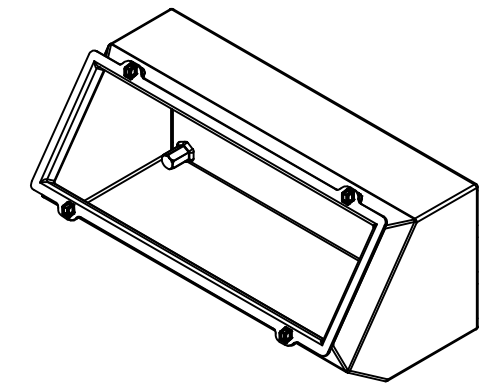

Isometric View



Tél: (450) 979-4373  
 Fax: (450) 979-4626  
[www.exmweb.com](http://www.exmweb.com)

Flatness  
Aplatissement

Max 3.0mm

Projection



Customer Client	Date
Drawn By / Dessiné Par: BoxCad: BoxCad	Date: 05-Sep-25
Material / Matière: 16 Ga Cold Rolled A1008 CS Type B (1.4mm)	
Color / Couleur: Asa-61 Grey	Finish / Fini: Smooth
Description: 1412SFMN 4" x 10.25" x 4.814" Body	Detail Rev.
Part Number / Numéro Pièce: 1412SF031004MNB	Rev. 3 / 9

SEE BILL OF MATERIAL ON LAST PAGE

This drawing is confidential and must not be reproduced or used without the consent of EXM

Ce dessin est confidentiel et ne doit pas être reproduit ou utilisé sans le consentement de EXM

**STANDARD FEATURES ARE NOT LISTED IN THIS HOLE TABLE**

**HOLE TABLE - BACK VIEW (CUSTOM FEATURE ONLY)**

CUT-OUT	XDIM	YDIM	DESCRIPTION
1	0.563	4.193	FOOT 885 ESCHMF1
2	9.687	0.000	FOOT 885 ESCHMF1
3	0.563	0.000	FOOT 885 ESCHMF1
4	9.687	4.193	FOOT 885 ESCHMF1
5	0.563	3.849	RIVET NUT M6_FH_CE (Inside)
6	9.687	0.344	RIVET NUT M6_FH_CE (Inside)
7	0.563	0.344	RIVET NUT M6_FH_CE (Inside)
8	9.687	3.849	RIVET NUT M6_FH_CE (Inside)

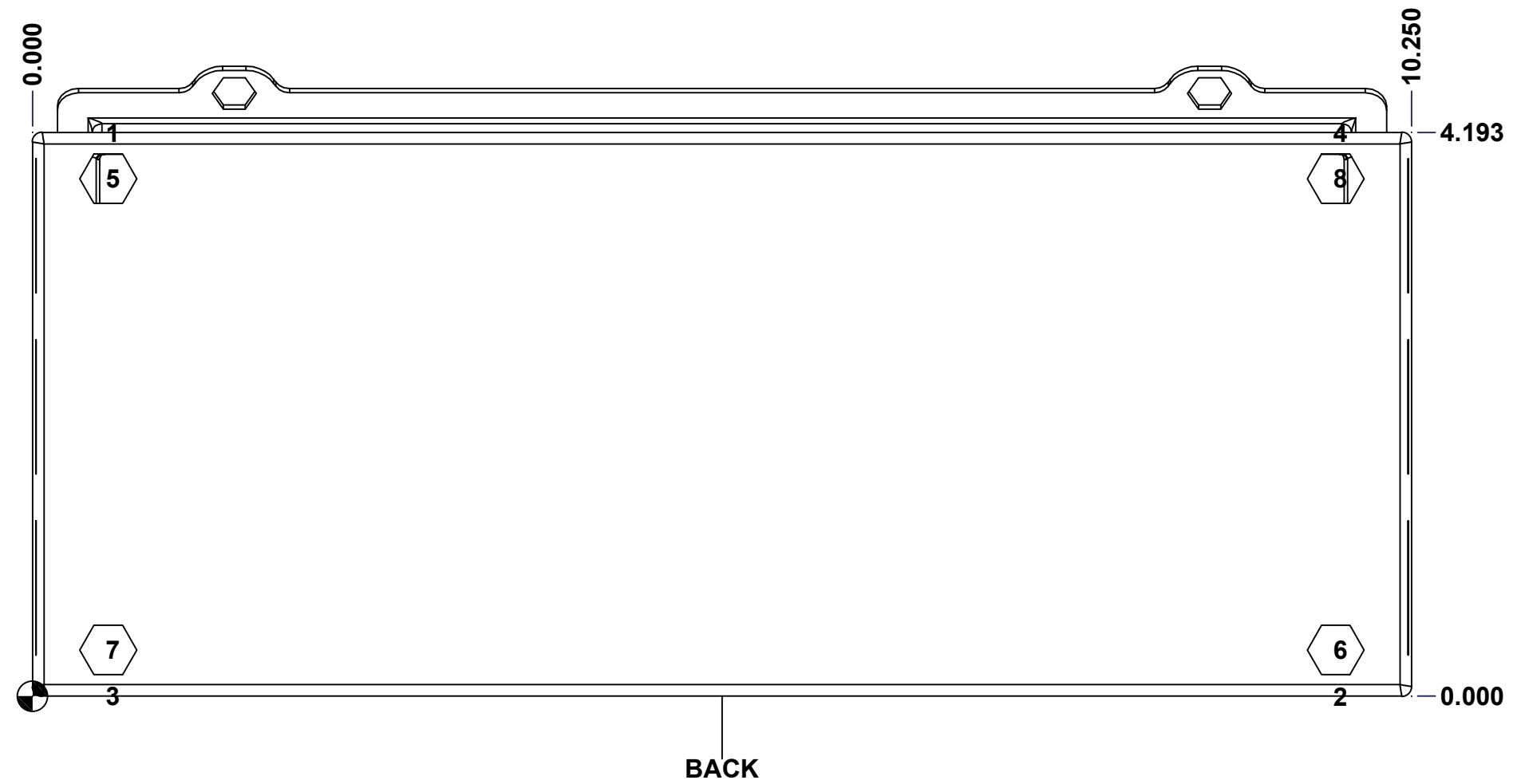

	Description	Status	
	1412SFMN 4" x 10.25" x 4.814" Body	(NULL)	
	Part Number Numéro Pièce	Rev.	
	<b>1412SF031004MNB</b>	<b>0</b>	4/9

This drawing is confidential and must not be reproduced or used without the consent of EXM

Ce dessin est confidentiel et ne doit pas être reproduit ou utilisé sans le consentement de EXM

<b>STANDARD FEATURES ARE NOT LISTED IN THIS HOLE TABLE</b>			
<b>HOLE TABLE - ANGLE VIEW (CUSTOM FEATURE ONLY)</b>			
CUT-OUT	XDIM	YDIM	DESCRIPTION
1	9.375	0.742	STANDOFF M6 x 10mm (Inside)

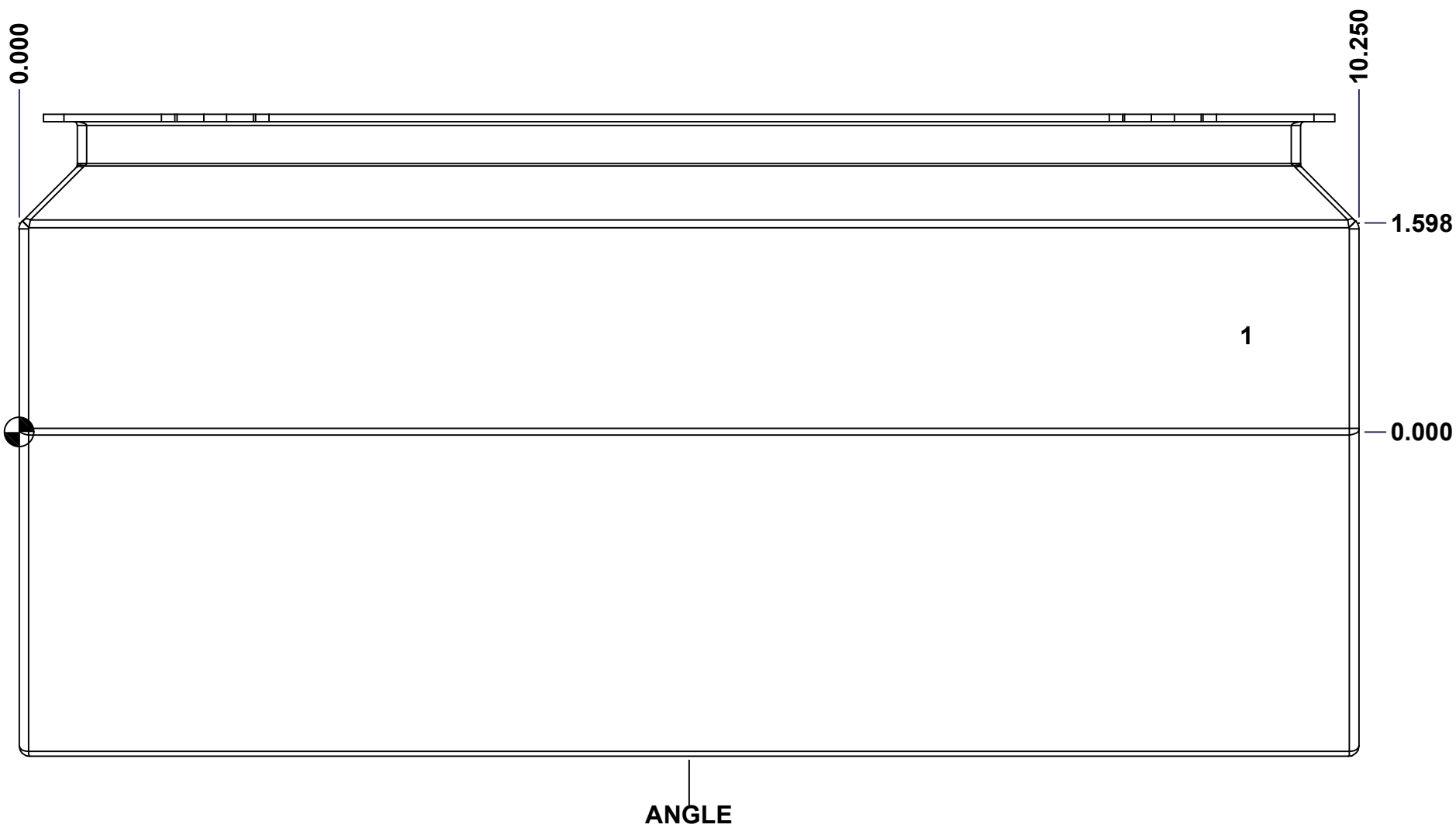

	Description	Status	
	1412SFMN 4" x 10.25" x 4.814" Body	(NULL)	
	Part Number Numéro Pièce	Rev.	
	<b>1412SF031004MNB</b>	<b>0</b>	5 9

This drawing is confidential and must not be reproduced or used without the consent of EXM

Ce dessin est confidentiel et ne doit pas être reproduit ou utilisé sans le consentement de EXM

No.	Revisions	Date	By/Par

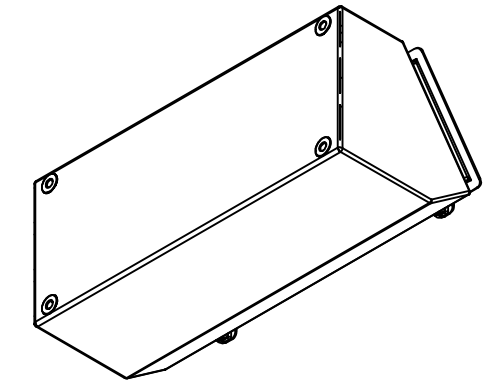

Isometric View

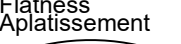
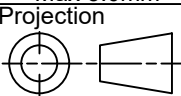

 Tél: (450) 979-4373 Fax: (450) 979-4626 <a href="http://www.exmweb.com">www.exmweb.com</a>		Flatness Aplatissement  Max 3.0mm
Customer Client		Projection 
Drawn By Dessiné Par BoxCad: BoxCad		Date 05-Sep-25
Material Matière 16 Ga Cold Rolled A1008 CS Type B (1.4mm)		
Color Couleur Asa-61 Grey	Finish Fini Smooth	
Description 1412SFMN 4" x 10.25" x 4.814" Body		Detail Rev.
Part Number Numéro Pièce <b>1412SF031004MNB</b>		Rev. 6 <b>0</b>

Qty	Part Number	Rev	Description
4	RIVET_NUT_M6_FH_CE	0	Rivet Nut M6 (Low Profile Close End)
1	STK-Q-08350	5	Standoff M6 x 10mm
1	STK-P-02400S	0	Powder Paint (Asa-61 Grey / Smooth)
4	RIVET_NUT_M5_FH_OE	0	Rivet Nut M5 (Low Profile Open End)
1	1412SF031004MNB-P	0	1412SFMN 4" x 10.25" x 4.814" Body Part
Parts List			

This drawing is confidential and must not be reproduced or used without the consent of EXM

Ce dessin est confidentiel et ne doit pas être reproduit ou utilisé sans le consentement de EXM

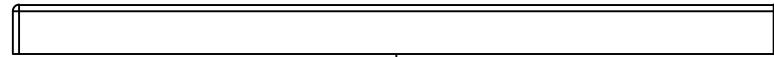

TOP

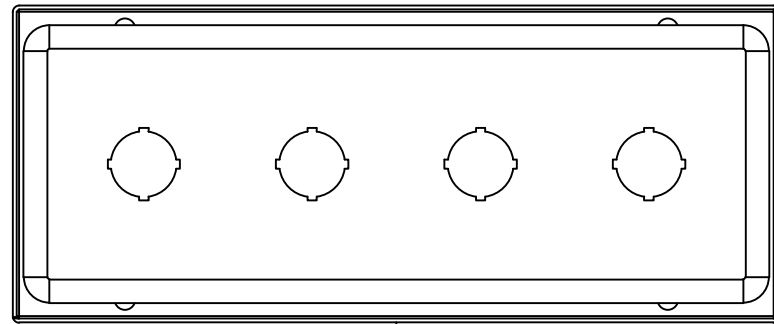

BACK

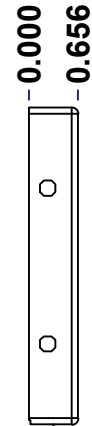

LEFT

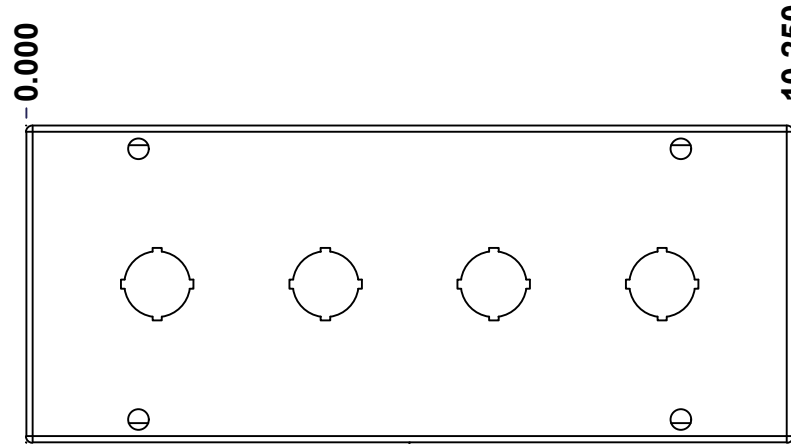

FRONT

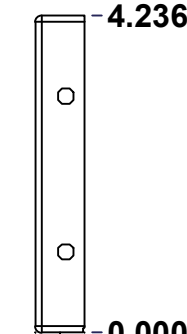

RIGHT

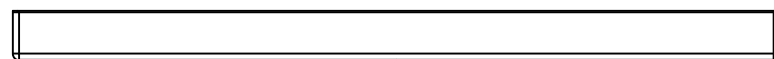

BOTTOM

No.	Revisions	Date	By/Par

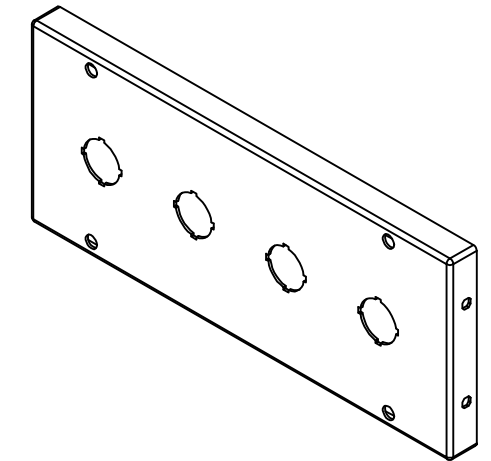

Isometric View



Tél: (450) 979-4373  
 Fax: (450) 979-4626  
[www.exmweb.com](http://www.exmweb.com)

Flatness  
Aplatissement

Max 3.0mm

Projection

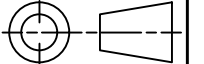

Customer Client	Date
Drawn By Dessiné Par BoxCad: BoxCad	Date 05-Sep-25
Material Matière 16 Ga Cold Rolled A1008 CS Type B (1.4mm)	
Color Couleur Asa-61 Grey	Finish Fini Smooth
Description 1412SFMN 4" x 10.25" Cover	Detail Rev.
Part Number Numéro Pièce 1412SF031004MNC	Rev. 0

SEE BILL OF MATERIAL ON LAST PAGE

This drawing is confidential and must not be reproduced or used without the consent of EXM

Ce dessin est confidentiel et ne doit pas être reproduit ou utilisé sans le consentement de EXM

STANDARD FEATURES ARE NOT LISTED IN THIS HOLE TABLE			
HOLE TABLE - FRONT VIEW (CUSTOM FEATURE ONLY)			
CUT-OUT	XDIM	YDIM	DESCRIPTION
1	8.500	2.118	22.5 mm Miniature Pushbutton
2	6.250	2.118	22.5 mm Miniature Pushbutton
3	4.000	2.118	22.5 mm Miniature Pushbutton
4	1.750	2.118	22.5 mm Miniature Pushbutton

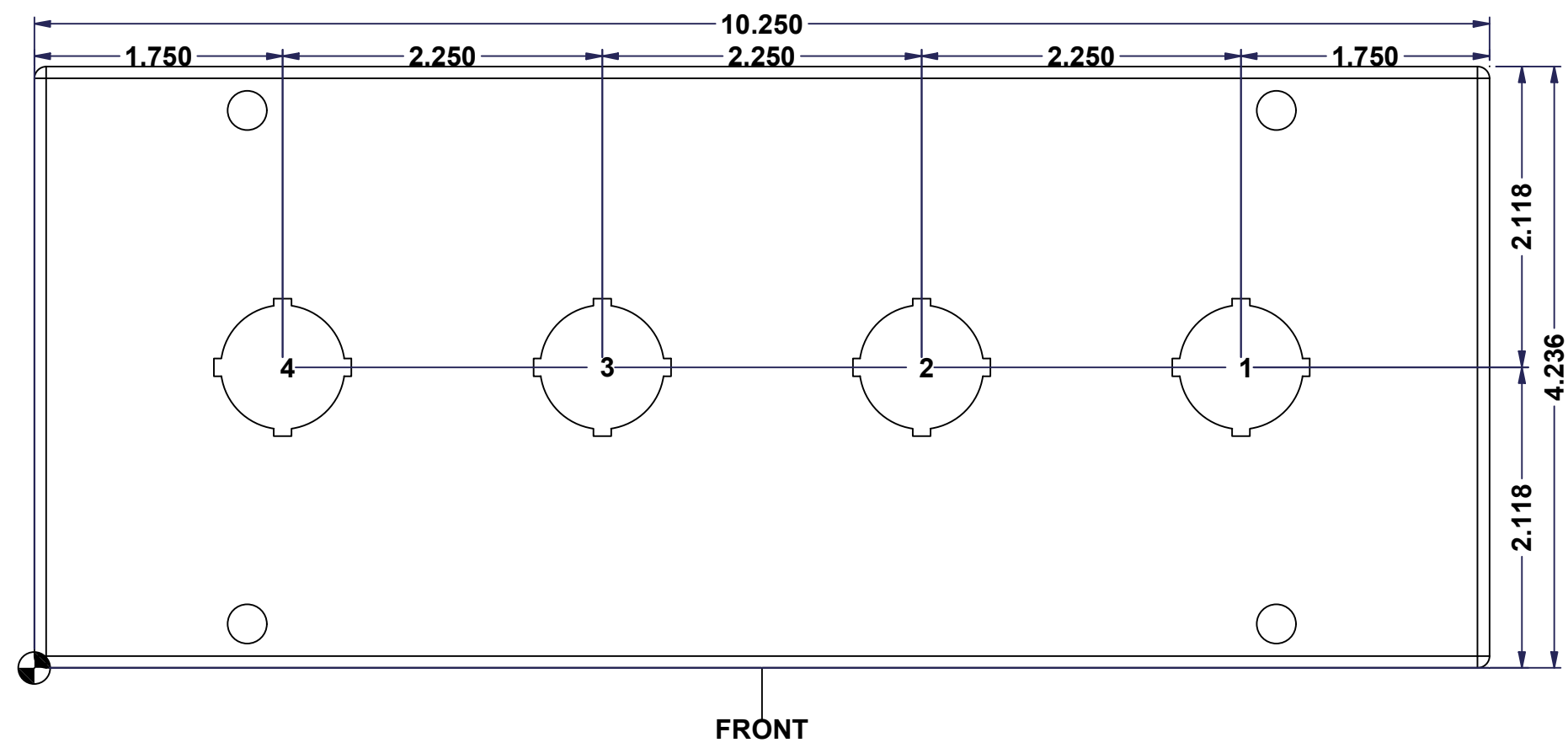

FRONT

	Description	Status	
	1412SFMN 4" x 10.25" Cover	(NULL)	
	Part Number Numéro Pièce	Rev.	
	<b>1412SF031004MNC</b>	<b>0</b>	8 9

This drawing is confidential and must not be reproduced or used without the consent of EXM

Ce dessin est confidentiel et ne doit pas être reproduit ou utilisé sans le consentement de EXM

No.	Revisions	Date	By/Par

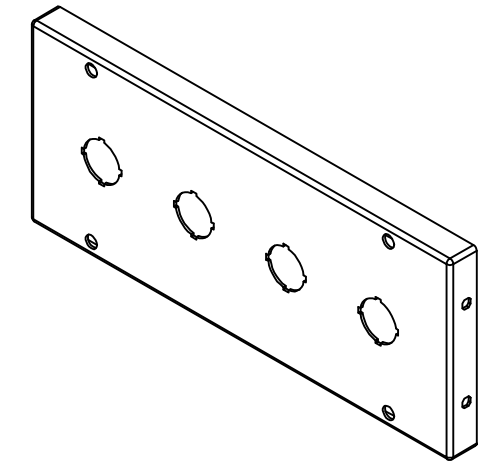

Isometric View

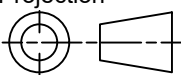

 Tél: (450) 979-4373 Fax: (450) 979-4626 <a href="http://www.exmweb.com">www.exmweb.com</a>		Flatness Aplatissement Max 3.0mm Projection 
Customer Client	Date	
Drawn By Dessiné Par	BoxCad: BoxCad	Date 05-Sep-25
Material Matière	16 Ga Cold Rolled A1008 CS Type B (1.4mm)	
Color Couleur	Asa-61 Grey	Finish Fini Smooth
Description		Detail Rev.
1412SFMN 4" x 10.25" Cover		
Part Number Numéro Pièce	Rev.	9
<b>1412SF031004MNC</b>	<b>0</b>	<b>9</b>

Qty	Part Name	Rev	Description
1	1412SF031004MNG	0	1412SF 4" x 10.25" Gasket
1	1412SF031004MNC-P	0	1412SFMN 4" x 10.25" Cover Part
1	STK-P-02400S	0	Powder Paint (Asa-61 Grey / Smooth)
Parts List			