

This drawing is confidential and must not be reproduced or used without the consent of EXM

Ce dessin est confidentiel et ne doit pas être reproduit ou utilisé sans le consentement de EXM

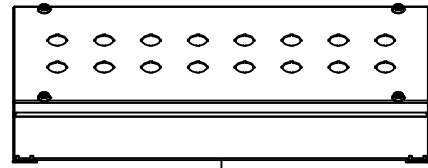

TOP

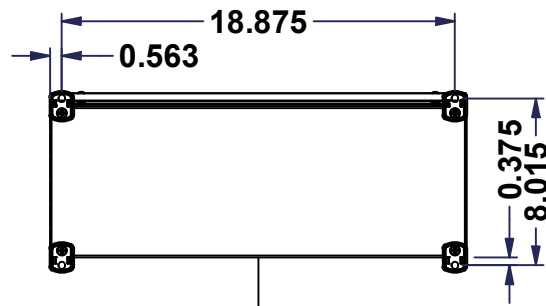

BACK

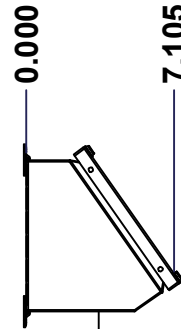

LEFT

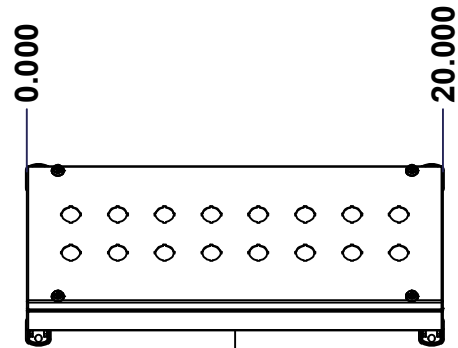

FRONT

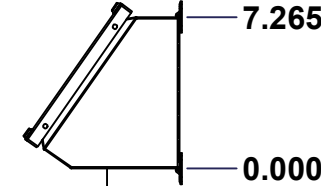

RIGHT

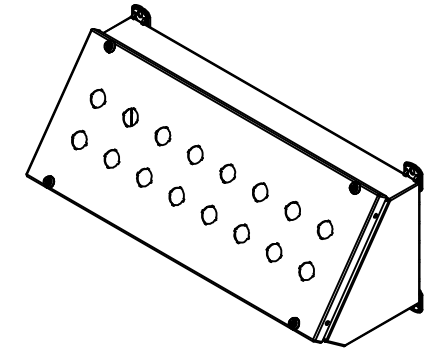

Isometric View

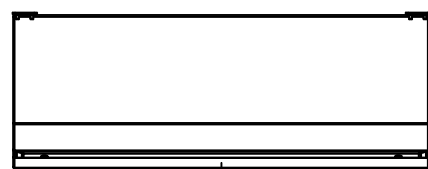

BOTTOM

| No. | Revisions | Date | By/Par |
|-----|-----------|------|--------|
|     |           |      |        |
|     |           |      |        |
|     |           |      |        |
|     |           |      |        |
|     |           |      |        |

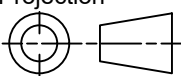
|  |   |   |
|--|---|---|
|  Tél: (450) 979-4373<br>Fax: (450) 979-4626<br><a href="http://www.exmweb.com">www.exmweb.com</a> |   | Flatness<br>Aplatissement<br>Max 3.0mm<br>Projection<br> |
| Customer Client  | Date                                      |   |
| Drawn By<br>Dessiné Par  | BoxCad: BoxCad                            | Date 05-Sep-25  |
| Material<br>Matière  | 16 Ga Cold Rolled A1008 CS Type B (1.4mm) |   |
| Color<br>Couleur   | Asa-61 Grey                               | Finish<br>Fini Smooth   |
| Description<br>1412SFMN 7.75" x 20" x 6.965" Assembly  |   | Detail Rev.   |
| Part Number<br>Numéro Pièce  | 1412SF071906MN                            | Rev. 1<br>0 9   |

SEE BILL OF MATERIAL ON LAST PAGE

This drawing is confidential and must not be reproduced or used without the consent of EXM

Ce dessin est confidentiel et ne doit pas être reproduit ou utilisé sans le consentement de EXM

| NOTE |  |
|------|--|
| ITEM | DESCRIPTION                                    |
| 1    | NEMA 4, 12 Enclosure (IP66)                    |
| 2    | C/W Standard ground standoffs on box and cover |
| 3    | W/O Standard door stiffener                    |
| 4    | W/O Inner panel                                |
| 5    | W/O Inner panel mounting standoffs             |
| 6    | C/W 885 ESCHMF1 Mounting Feet (Installed)      |

| No. | Revisions | Date | By/Par |
|-----|-----------|------|--------|
|     |           |      |        |
|     |           |      |        |
|     |           |      |        |
|     |           |      |        |
|     |           |      |        |
|     |           |      |        |

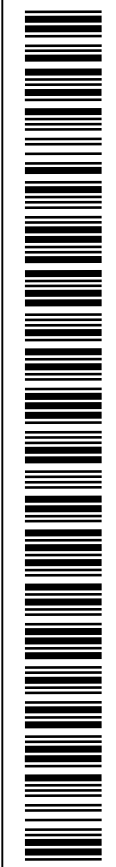
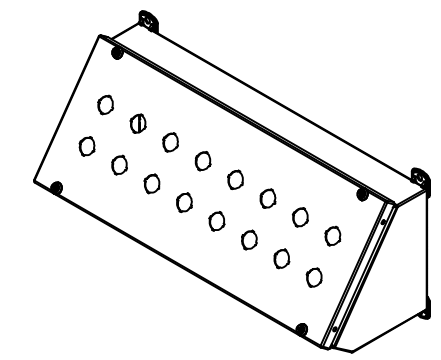

Isometric View



Tél: (450) 979-4373  
 Fax: (450) 979-4626  
[www.exmweb.com](http://www.exmweb.com)

Flatness  
Aplatissement  
Max 3.0mm  
Projection

|   |                 |
|---|-----------------|
| Customer Client   | Date            |
| Drawn By / Dessiné Par: BoxCad: BoxCad                        | Date: 05-Sep-25 |
| Material / Matière: 16 Ga Cold Rolled A1008 CS Type B (1.4mm) |                 |

|                              |                       |
|------------------------------|-----------------------|
| Color / Couleur: Asa-61 Grey | Finish / Fini: Smooth |
|------------------------------|-----------------------|

|   |             |
|---|-------------|
| Description: 1412SFMN 7.75" x 20" x 6.965" Assembly | Detail Rev. |
|---|-------------|

|   |        |   |   |
|---|--------|---|---|
| Part Number / Numéro Pièce: <b>1412SF071906MN</b> | Rev. 0 | 2 | 9 |
|---|--------|---|---|

| PACKING               |     |  |
|-----------------------|-----|--|
| ITEM                  | QTY | DESCRIPTION                                |
| Cardboard sleeve      | 2   | Top and Bottom                             |
| Cardboard strip       | 2   | Between back of enclosure and inner panel  |
| Plastic bag           | 1   | To protect cover surface and inside gasket |
| Plastic strap - Black | 2   | To Squeeze the 2 cardboard sleeve together |
| Packaging label       | 1   | White label with product number            |

| Qty        | Part Number     | Rev | Description                            |
|------------|-----------------|-----|--|
| 1          | 885 ESSCHMFQ    | 0   | 5412 ESSCH Mounting Feet Accessory Kit |
| 1          | STK-K-02920     | 3   | 5412 ESSC Accessory Kit                |
| 1          | 1412SF071906MNC | 0   | 1412SFMN 7.75" x 20" Cover             |
| 1          | 1412SF071906MNB | 0   | 1412SFMN 7.75" x 20" x 6.965" Body     |
| Parts List |                 |     |  |

This drawing is confidential and must not be reproduced or used without the consent of EXM

Ce dessin est confidentiel et ne doit pas être reproduit ou utilisé sans le consentement de EXM

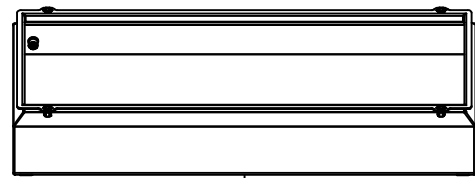

TOP

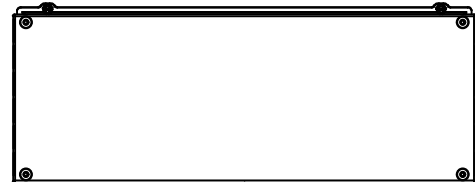

BACK

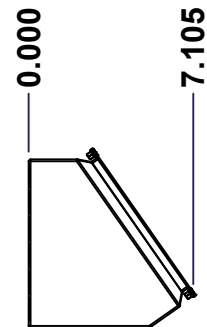

LEFT



FRONT

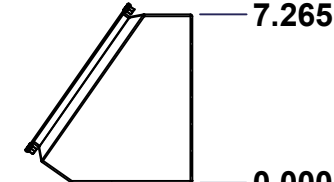

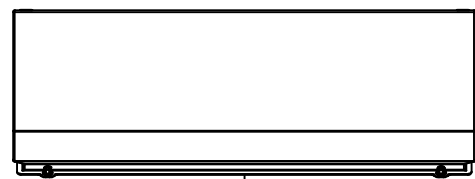

RIGHT

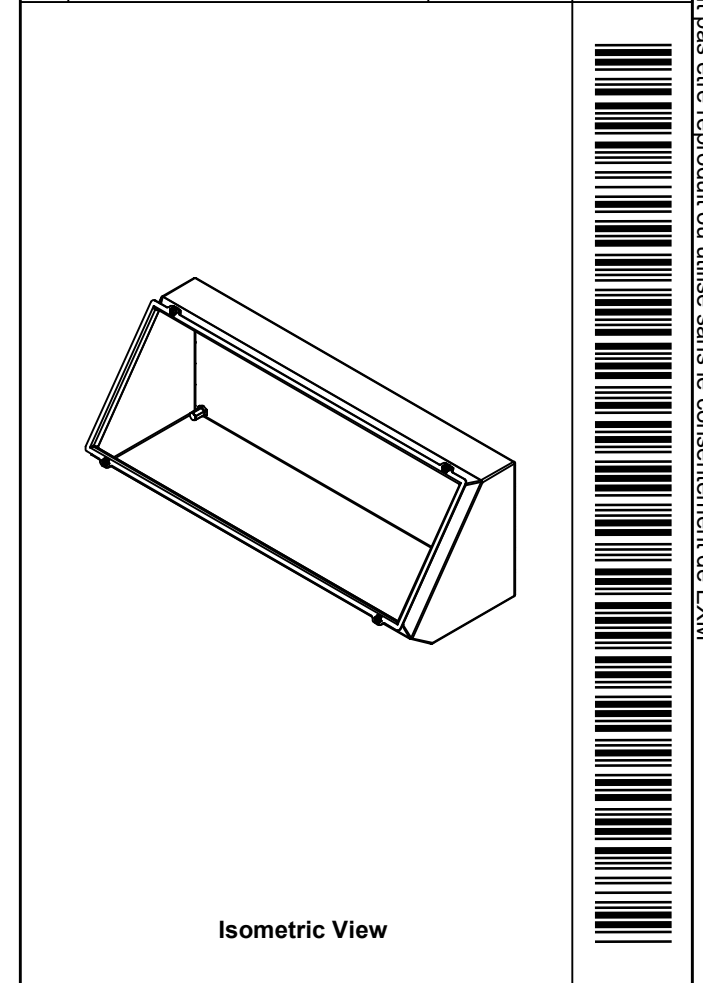

BOTTOM

| No. | Revisions | Date | By/Par |
|-----|-----------|------|--------|
|     |           |      |        |
|     |           |      |        |
|     |           |      |        |
|     |           |      |        |

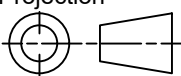

|  |   |   |
|--|---|---|
|  Tél: (450) 979-4373<br>Fax: (450) 979-4626<br><a href="http://www.exmweb.com">www.exmweb.com</a> |   | Flatness<br>Aplatissement<br>Max 3.0mm<br>Projection<br> |
| Customer Client  | Date                                      |   |
| Drawn By<br>Dessiné Par  | BoxCad: BoxCad                            | Date 05-Sep-25  |
| Material<br>Matière  | 16 Ga Cold Rolled A1008 CS Type B (1.4mm) |   |
| Color<br>Couleur   | Asa-61 Grey                               | Finish<br>Fini Smooth   |
| Description<br>1412SFMN 7.75" x 20" x 6.965" Body  |   | Detail Rev.   |
| Part Number<br>Numéro Pièce  | 1412SF071906MNB                           | Rev. 3<br>0 9   |

SEE BILL OF MATERIAL ON LAST PAGE

This drawing is confidential and must not be reproduced or used without the consent of EXM

Ce dessin est confidentiel et ne doit pas être reproduit ou utilisé sans le consentement de EXM

| STANDARD FEATURES ARE NOT LISTED IN THIS HOLE TABLE |        |       |                             |
|---|--------|-------|-----------------------------|
| HOLE TABLE - BACK VIEW (CUSTOM FEATURE ONLY)        |        |       |                             |
| CUT-OUT   | XDIM   | YDIM  | DESCRIPTION                 |
| 1   | 19.437 | 0.000 | FOOT 885 ESCHMF1            |
| 2   | 0.563  | 0.000 | FOOT 885 ESCHMF1            |
| 3   | 19.437 | 7.265 | FOOT 885 ESCHMF1            |
| 4   | 0.563  | 7.265 | FOOT 885 ESCHMF1            |
| 5   | 19.437 | 0.344 | RIVET NUT M6_FH_CE (Inside) |
| 6   | 0.563  | 0.344 | RIVET NUT M6_FH_CE (Inside) |
| 7   | 19.437 | 6.921 | RIVET NUT M6_FH_CE (Inside) |
| 8   | 0.563  | 6.921 | RIVET NUT M6_FH_CE (Inside) |

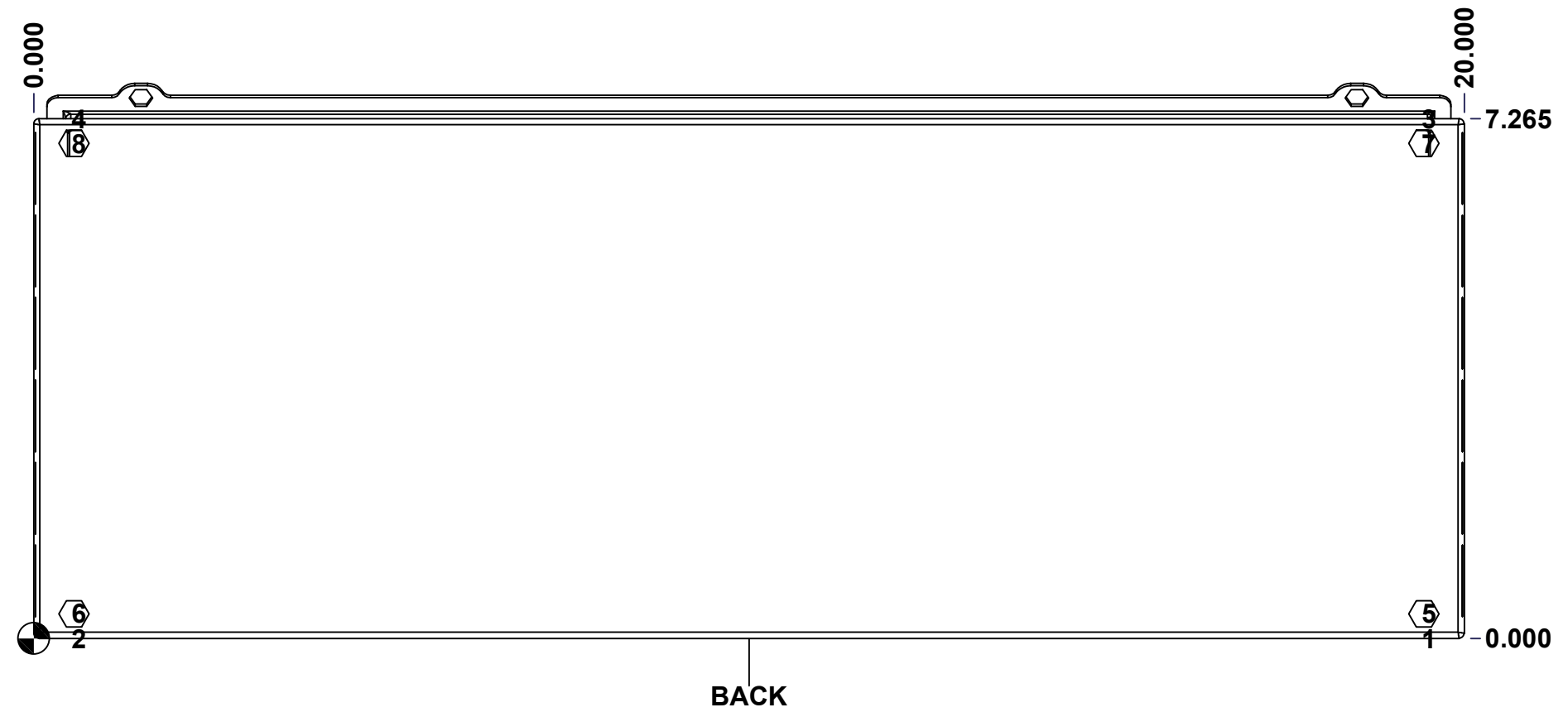

|  |                                    |          |        |
|--|------------------------------------|----------|--------|
|  | Description                        | Status   |        |
|  | 1412SFMN 7.75" x 20" x 6.965" Body | (NULL)   |        |
|  | Part Number<br>Numéro Pièce        | Rev.     |        |
|  | <b>1412SF071906MNB</b>             | <b>0</b> | 4<br>9 |

This drawing is confidential and must not be reproduced or used without the consent of EXM

Ce dessin est confidentiel et ne doit pas être reproduit ou utilisé sans le consentement de EXM

| <b>STANDARD FEATURES ARE NOT LISTED IN THIS HOLE TABLE</b> |        |       |                             |
|--|--------|-------|-----------------------------|
| <b>HOLE TABLE - ANGLE VIEW (CUSTOM FEATURE ONLY)</b>       |        |       |                             |
| CUT-OUT  | XDIM   | YDIM  | DESCRIPTION                 |
| 1  | 19.125 | 0.742 | STANDOFF M6 x 10mm (Inside) |

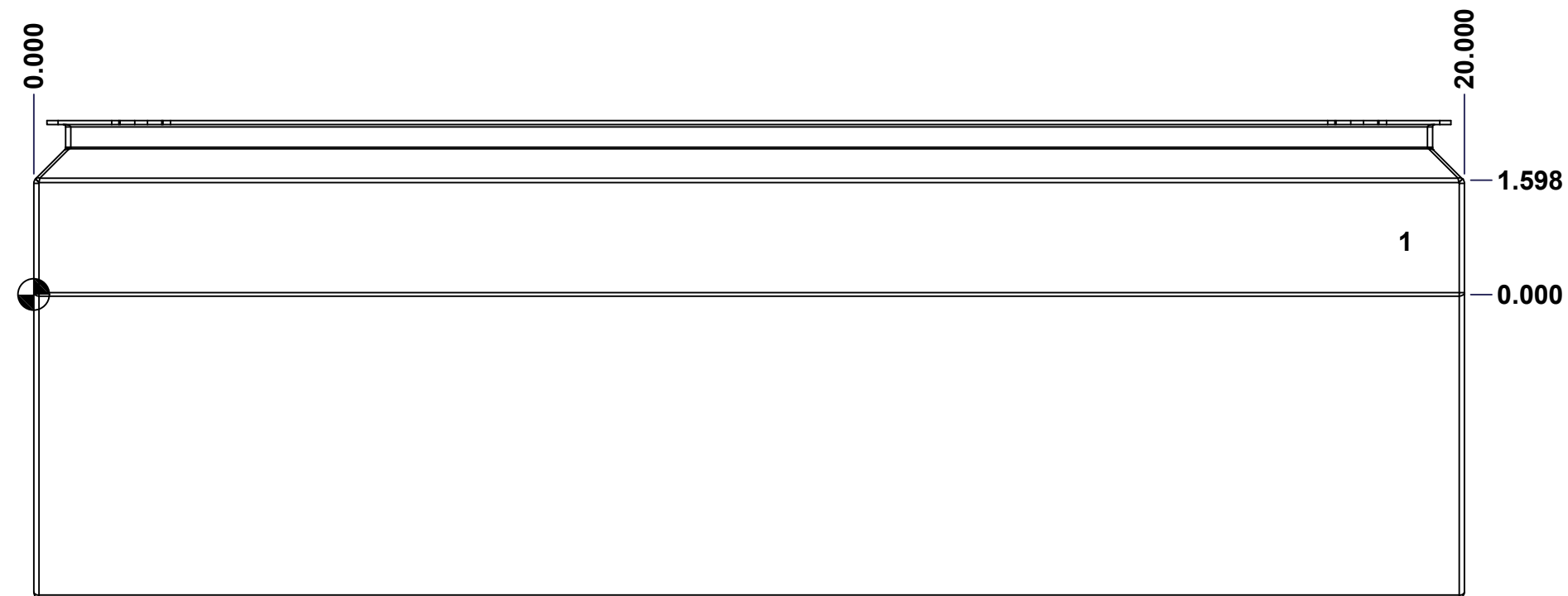

ANGLE

|  |                                    |          |   |
|--|------------------------------------|----------|---|
|  | Description                        | Status   |   |
|  | 1412SFMN 7.75" x 20" x 6.965" Body | (NULL)   |   |
|  | Part Number<br>Numéro Pièce        | Rev.     | 5 |
|  | <b>1412SF071906MNB</b>             | <b>0</b> | 9 |

This drawing is confidential and must not be reproduced or used without the consent of EXM

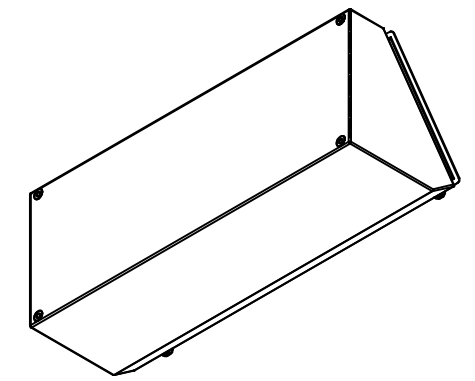

Ce dessin est confidentiel et ne doit pas être reproduit ou utilisé sans le consentement de EXM

| No. | Revisions | Date | By/Par |
|-----|-----------|------|--------|
|     |           |      |        |
|     |           |      |        |
|     |           |      |        |
|     |           |      |        |
|     |           |      |        |



Isometric View



|  |                       |   |
|--|-----------------------|---|
|  Tél: (450) 979-4373<br>Fax: (450) 979-4626<br><a href="http://www.exmweb.com">www.exmweb.com</a> |                       | Flatness<br>Aplatissement<br><br>Max 3.0mm |
| Customer<br>Client   |                       | Date  |
| Drawn By<br>Dessiné Par BoxCad: BoxCad   |                       | Date 05-Sep-25  |
| Material<br>Matière 16 Ga Cold Rolled A1008 CS Type B (1.4mm)  |                       |   |
| Color<br>Couleur Asa-61 Grey   | Finish<br>Fini Smooth |   |
| Description<br>1412SFMN 7.75" x 20" x 6.965" Body  |                       | Detail Rev.   |
| Part Number<br>Numéro Pièce<br><b>1412SF071906MNB</b>  |                       | Rev. 6<br><b>0</b>  |

| Qty        | Part Number        | Rev | Description                             |
|------------|--------------------|-----|---|
| 4          | RIVET_NUT_M6_FH_CE | 0   | Rivet Nut M6 (Low Profile Close End)    |
| 1          | STK-Q-08350        | 5   | Standoff M6 x 10mm                      |
| 1          | STK-P-02400S       | 0   | Powder Paint (Asa-61 Grey / Smooth)     |
| 4          | RIVET_NUT_M5_FH_OE | 0   | Rivet Nut M5 (Low Profile Open End)     |
| 1          | 1412SF071906MNB-P  | 0   | 1412SFMN 7.75" x 20" x 6.965" Body Part |
| Parts List |                    |     |   |

This drawing is confidential and must not be reproduced or used without the consent of EXM

Ce dessin est confidentiel et ne doit pas être reproduit ou utilisé sans le consentement de EXM

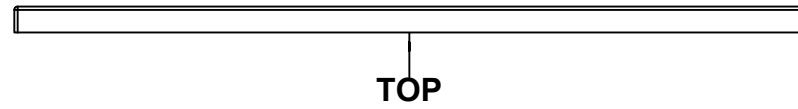

TOP

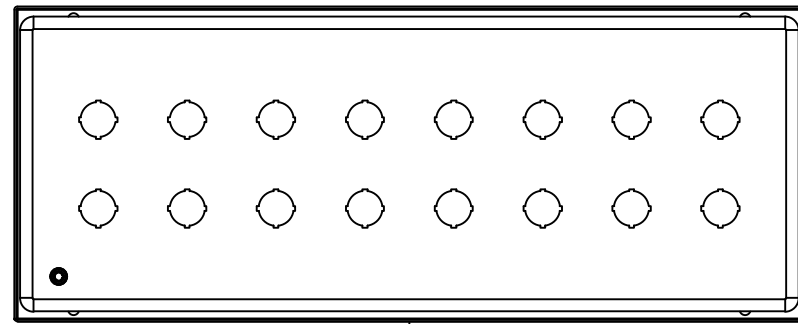

BACK

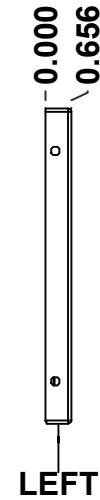

LEFT

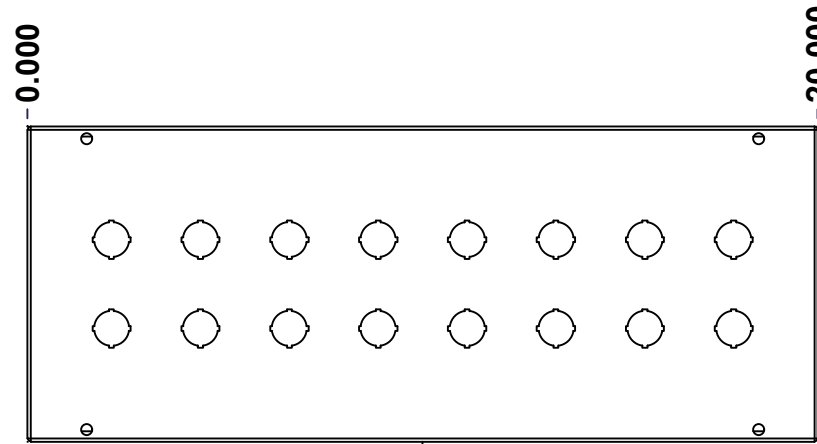

FRONT

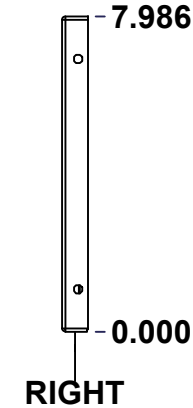

RIGHT

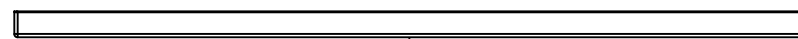

BOTTOM

| No. | Revisions | Date | By/Par |
|-----|-----------|------|--------|
|     |           |      |        |
|     |           |      |        |
|     |           |      |        |
|     |           |      |        |

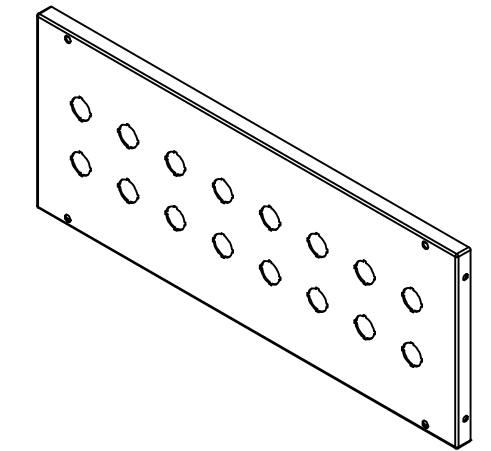

Isometric View



Tél: (450) 979-4373  
 Fax: (450) 979-4626  
[www.exmweb.com](http://www.exmweb.com)

Flatness  
Aplatissement

Max 3.0mm

Projection

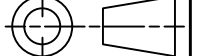

|                         |   |
|-------------------------|---|
| Customer Client         | Date                                      |
| Drawn By<br>Dessiné Par | Date 05-Sep-25                            |
| Material<br>Matière     | 16 Ga Cold Rolled A1008 CS Type B (1.4mm) |

|                  |             |                |        |
|------------------|-------------|----------------|--------|
| Color<br>Couleur | Asa-61 Grey | Finish<br>Fini | Smooth |
|------------------|-------------|----------------|--------|

|                            |             |
|----------------------------|-------------|
| Description                | Detail Rev. |
| 1412SFMN 7.75" x 20" Cover |             |

|                             |      |   |
|-----------------------------|------|---|
| Part Number<br>Numéro Pièce | Rev. | 7 |
| 1412SF071906MNC             | 0    | 9 |

SEE BILL OF MATERIAL ON LAST PAGE

This drawing is confidential and must not be reproduced or used without the consent of EXM

Ce dessin est confidentiel et ne doit pas être reproduit ou utilisé sans le consentement de EXM

| STANDARD FEATURES ARE NOT LISTED IN THIS HOLE TABLE |        |       |                              |
|---|--------|-------|------------------------------|
| HOLE TABLE - FRONT VIEW (CUSTOM FEATURE ONLY)       |        |       |                              |
| CUT-OUT   | XDIM   | YDIM  | DESCRIPTION                  |
| 1   | 17.875 | 5.118 | 22.5 mm Miniature Pushbutton |
| 2   | 15.625 | 5.118 | 22.5 mm Miniature Pushbutton |
| 3   | 13.375 | 5.118 | 22.5 mm Miniature Pushbutton |
| 4   | 11.125 | 5.118 | 22.5 mm Miniature Pushbutton |
| 5   | 8.875  | 5.118 | 22.5 mm Miniature Pushbutton |
| 6   | 6.625  | 5.118 | 22.5 mm Miniature Pushbutton |
| 7   | 4.375  | 5.118 | 22.5 mm Miniature Pushbutton |
| 8   | 2.125  | 5.118 | 22.5 mm Miniature Pushbutton |
| 9   | 17.875 | 2.868 | 22.5 mm Miniature Pushbutton |
| 10  | 15.625 | 2.868 | 22.5 mm Miniature Pushbutton |
| 11  | 13.375 | 2.868 | 22.5 mm Miniature Pushbutton |
| 12  | 11.125 | 2.868 | 22.5 mm Miniature Pushbutton |
| 13  | 8.875  | 2.868 | 22.5 mm Miniature Pushbutton |
| 14  | 6.625  | 2.868 | 22.5 mm Miniature Pushbutton |
| 15  | 4.375  | 2.868 | 22.5 mm Miniature Pushbutton |
| 16  | 2.125  | 2.868 | 22.5 mm Miniature Pushbutton |
| 17  | 18.875 | 1.145 | STANDOFF M6 x 10mm (Inside)  |

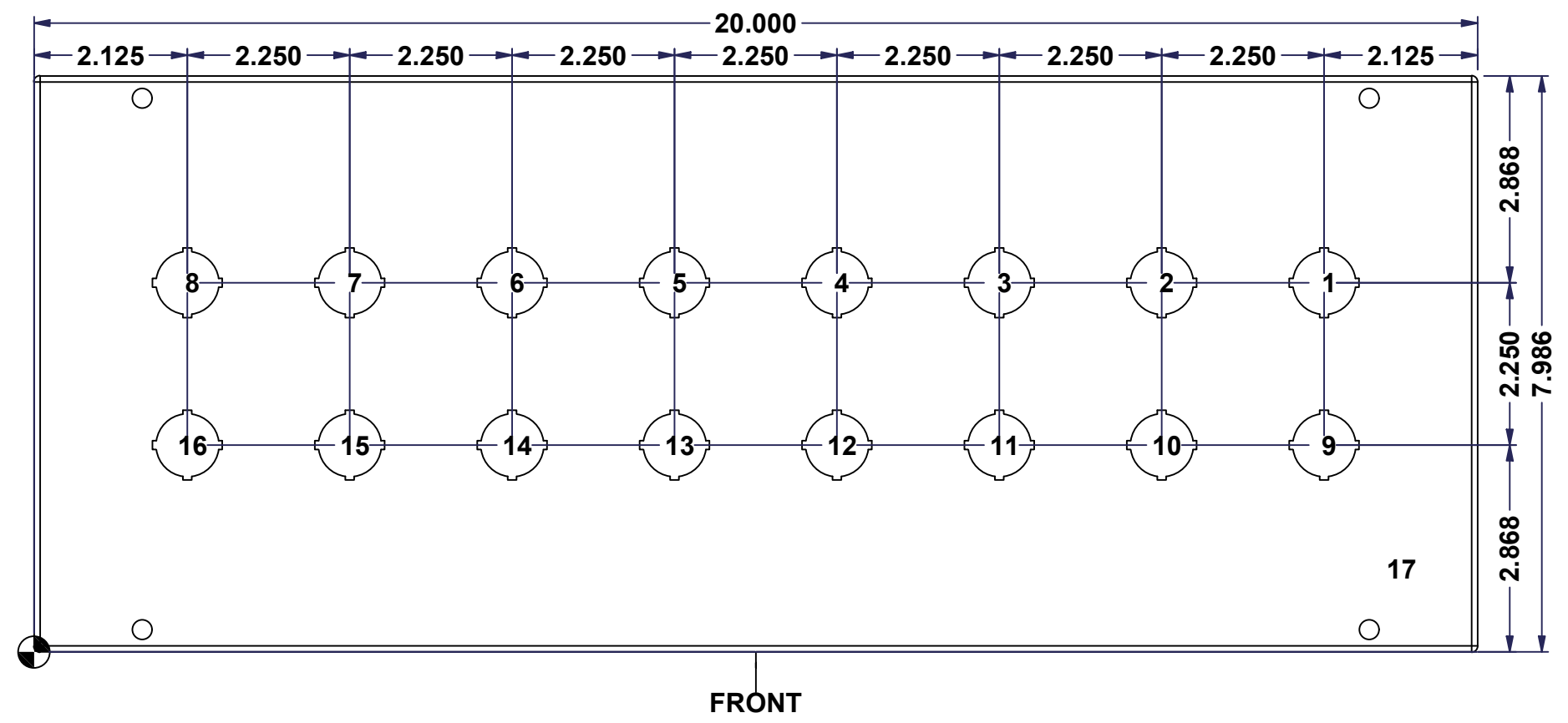

FRONT

|  |                             |          |
|--|-----------------------------|----------|
|  | Description                 | Status   |
|  | 1412SFMN 7.75" x 20" Cover  | (NULL)   |
|  | Part Number<br>Numéro Pièce | Rev.     |
|  | <b>1412SF071906MNC</b>      | <b>0</b> |
|  |                             | 8        |
|  |                             | 9        |

This drawing is confidential and must not be reproduced or used without the consent of EXM

Ce dessin est confidentiel et ne doit pas être reproduit ou utilisé sans le consentement de EXM

| No. | Revisions | Date | By/Par |
|-----|-----------|------|--------|
|     |           |      |        |
|     |           |      |        |
|     |           |      |        |
|     |           |      |        |
|     |           |      |        |

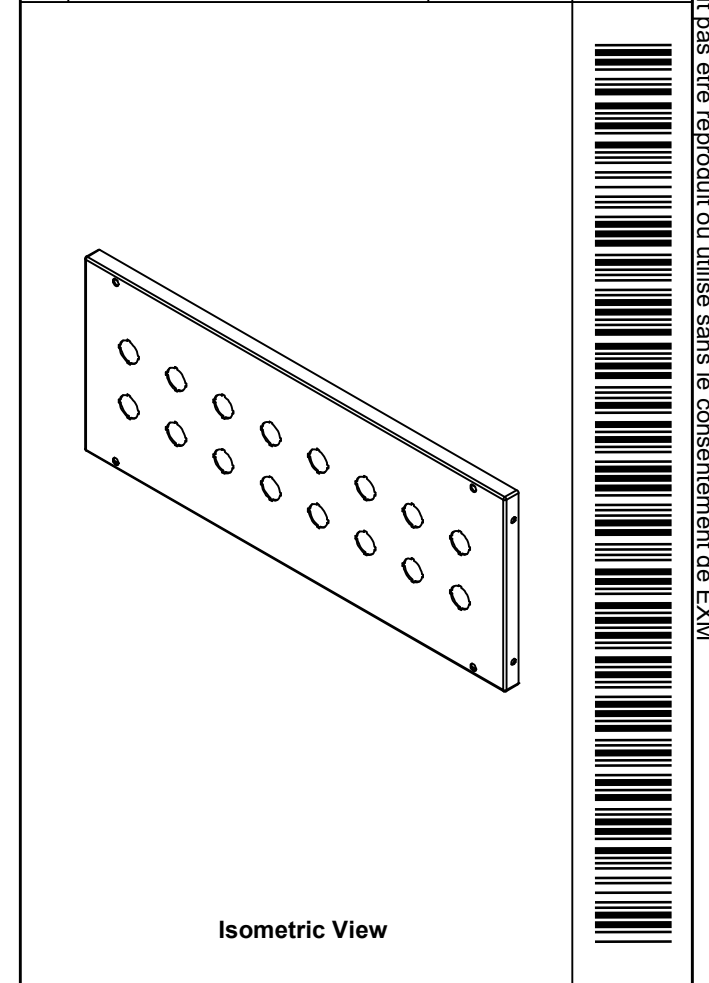

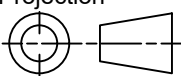
|  |   |   |
|--|---|---|
|  Tél: (450) 979-4373<br>Fax: (450) 979-4626<br><a href="http://www.exmweb.com">www.exmweb.com</a> |   | Flatness<br>Aplatissement<br>Max 3.0mm<br>Projection<br> |
| Customer Client  | Date                                      |   |
| Drawn By<br>Dessiné Par  | BoxCad: BoxCad                            | Date 05-Sep-25  |
| Material<br>Matière  | 16 Ga Cold Rolled A1008 CS Type B (1.4mm) |   |
| Color<br>Couleur   | Asa-61 Grey                               | Finish<br>Fini Smooth   |
| Description  |   | Detail Rev.   |
| 1412SFMN 7.75" x 20" Cover   |   |   |
| Part Number<br>Numéro Pièce  | Rev.                                      | 9   |
| <b>1412SF071906MNC</b>   | <b>0</b>                                  | <b>9</b>  |

| Qty        | Part Name         | Rev | Description                         |
|------------|-------------------|-----|-------------------------------------|
| 1          | STK-Q-08350       | 5   | Standoff M6 x 10mm                  |
| 1          | 1412SF071906MNG   | 0   | 1412SF 7.75" x 20" Gasket           |
| 1          | 1412SF071906MNC-P | 0   | 1412SFMN 7.75" x 20" Cover Part     |
| 1          | STK-P-02400S      | 0   | Powder Paint (Asa-61 Grey / Smooth) |
| Parts List |                   |     |                                     |