

This drawing is confidential and must not be reproduced or used without the consent of EXM

Ce dessin est confidentiel et ne doit pas être reproduit ou utilisé sans le consentement de EXM

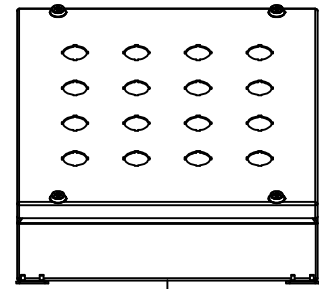

TOP

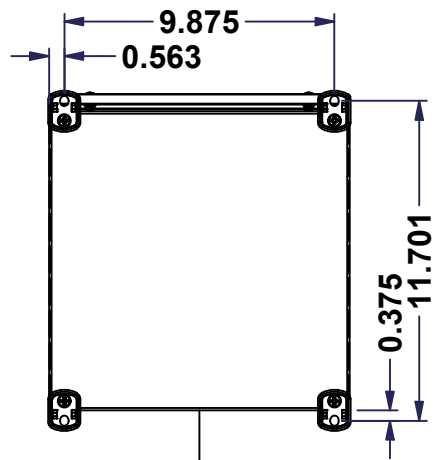

BACK

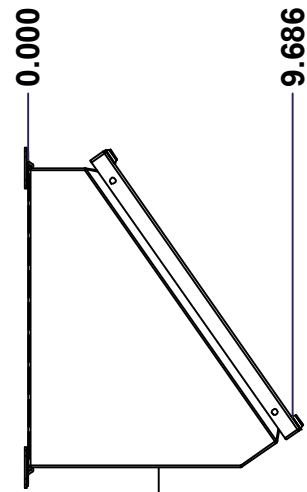

LEFT

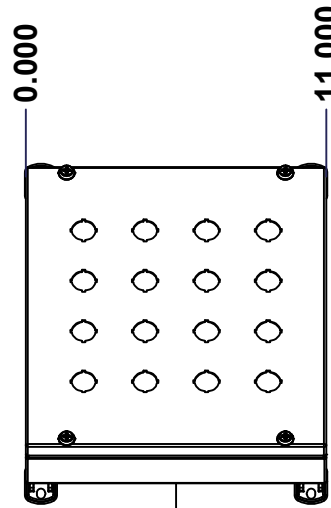

FRONT

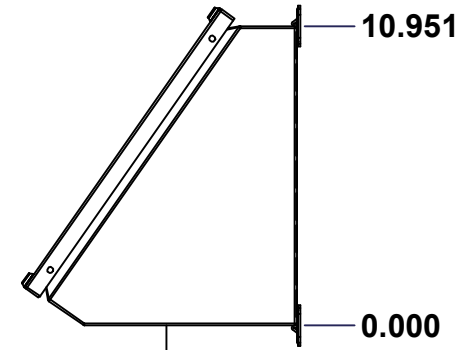

RIGHT

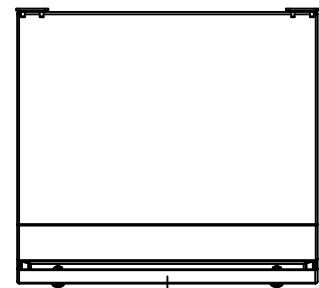

BOTTOM

No.	Revisions	Date	By/Par

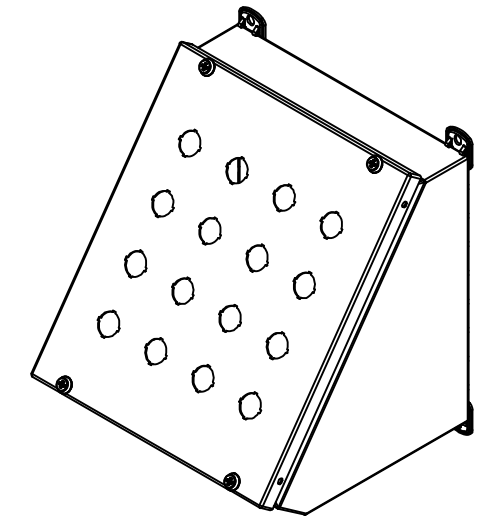

Isometric View



Tél: (450) 979-4373  
 Fax: (450) 979-4626  
[www.exmweb.com](http://www.exmweb.com)

Flatness  
Aplatissement

Max 3.0mm

Projection



Customer Client	Date
Drawn By / Dessiné Par: BoxCad: BoxCad	Date: 05-Sep-25
Material / Matière: 16 Ga Cold Rolled A1008 CS Type B (1.4mm)	
Color / Couleur: Asa-61 Grey	Finish / Fini: Smooth
Description: 1412SFMN 12.25" x 11" x 9.546" Assembly	Detail Rev.
Part Number / Numéro Pièce: 1412SF111009MN	Rev. 1
SEE BILL OF MATERIAL ON LAST PAGE	0

This drawing is confidential and must not be reproduced or used without the consent of EXM

Ce dessin est confidentiel et ne doit pas être reproduit ou utilisé sans le consentement de EXM

NOTE	
ITEM	DESCRIPTION
1	NEMA 4, 12 Enclosure (IP66)
2	C/W Standard ground standoffs on box and cover
3	W/O Standard door stiffener
4	W/O Inner panel
5	W/O Inner panel mounting standoffs
6	C/W 885 ESCHMF1 Mounting Feet (Installed)

No.	Revisions	Date	By/Par

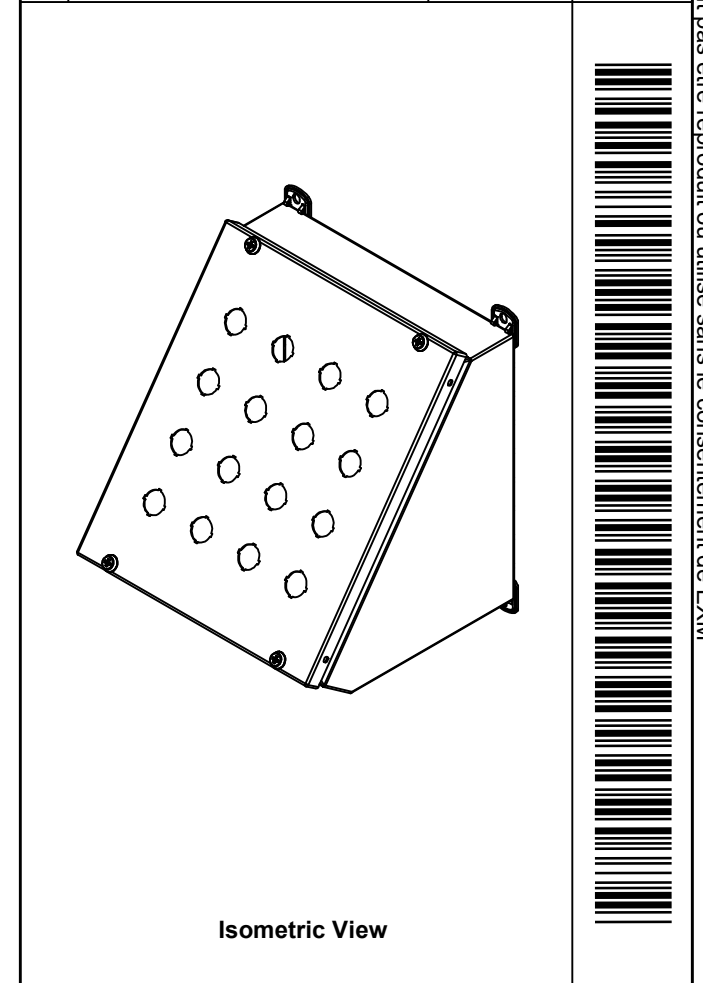

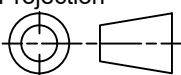
 Tél: (450) 979-4373 Fax: (450) 979-4626 <a href="http://www.exmweb.com">www.exmweb.com</a>	Flatness Aplatissement	Max 3.0mm
	Projection	
Customer Client	Date	
Drawn By Dessiné Par	BoxCad: BoxCad	Date 05-Sep-25
Material Matière	16 Ga Cold Rolled A1008 CS Type B (1.4mm)	
Color Couleur	Asa-61 Grey	Finish Fini Smooth
Description	Detail Rev.	
1412SFMN 12.25" x 11" x 9.546" Assembly		
Part Number Numéro Pièce	1412SF111009MN	Rev. 0
		2
		9

PACKING		
ITEM	QTY	DESCRIPTION
Cardboard sleeve	2	Top and Bottom
Cardboard strip	2	Between back of enclosure and inner panel
Plastic bag	1	To protect cover surface and inside gasket
Plastic strap - Black	2	To Squeeze the 2 cardboard sleeve together
Packaging label	1	White label with product number

Qty	Part Number	Rev	Description
1	885 ESSCHMFQ	0	5412 ESSCH Mounting Feet Accessory Kit
1	STK-K-02920	3	5412 ESSC Accessory Kit
1	1412SF111009MNC	0	1412SFMN 12.25" x 11" Cover
1	1412SF111009MNB	0	1412SFMN 12.25" x 11" x 9.546" Body
Parts List			

This drawing is confidential and must not be reproduced or used without the consent of EXM

Ce dessin est confidentiel et ne doit pas être reproduit ou utilisé sans le consentement de EXM

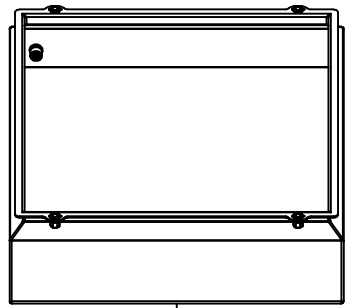

TOP

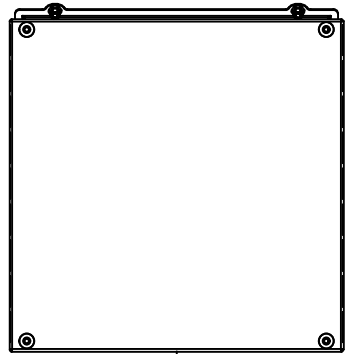

BACK

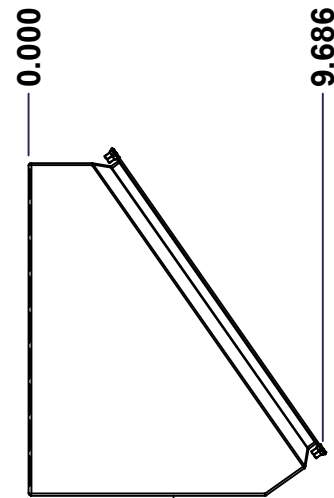

LEFT

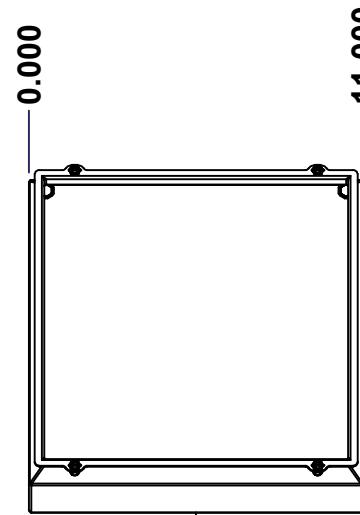

FRONT

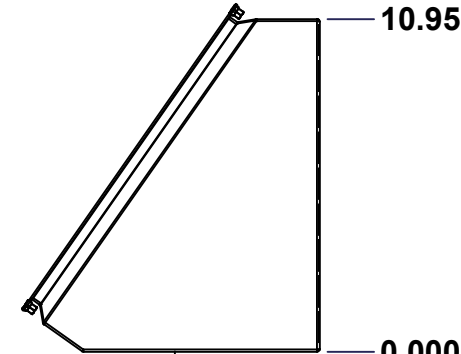

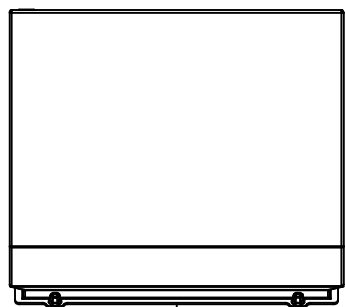

RIGHT

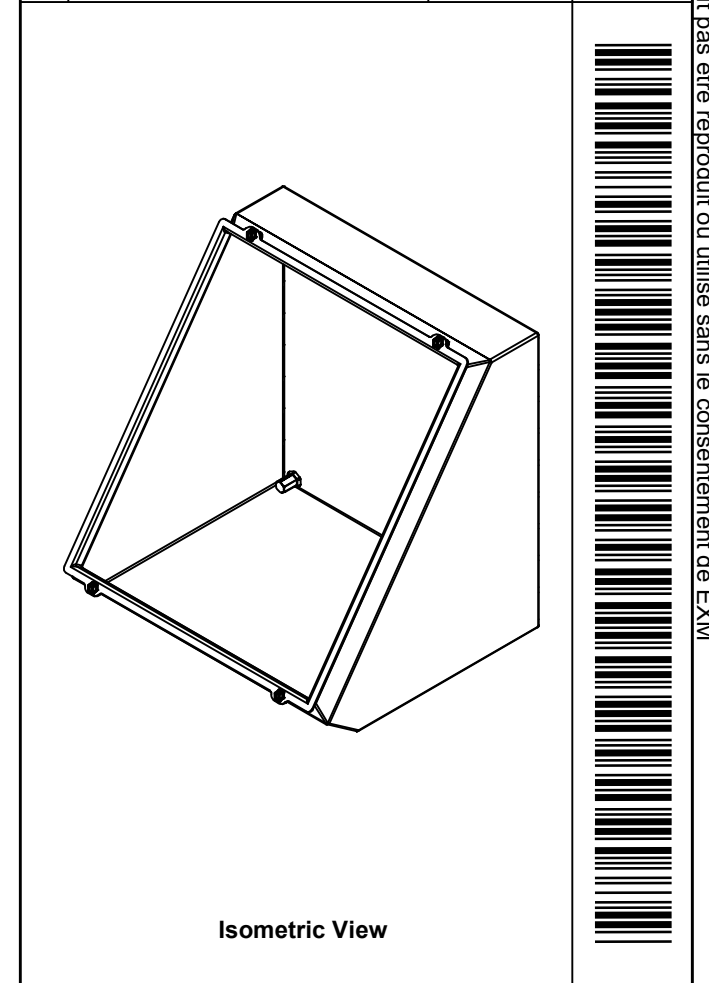

BOTTOM

No.	Revisions	Date	By/Par

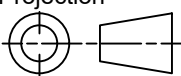

 Tél: (450) 979-4373 Fax: (450) 979-4626 <a href="http://www.exmweb.com">www.exmweb.com</a>		Flatness Aplatissement Max 3.0mm Projection 
Customer Client	Date	
Drawn By Dessiné Par	BoxCad: BoxCad	Date 05-Sep-25
Material Matière	16 Ga Cold Rolled A1008 CS Type B (1.4mm)	
Color Couleur	Asa-61 Grey	Finish Fini Smooth
Description	Detail Rev.	
1412SFMN 12.25" x 11" x 9.546" Body		
Part Number Numéro Pièce	Rev.	3
1412SF111009MNB	0	9

SEE BILL OF MATERIAL ON LAST PAGE

This drawing is confidential and must not be reproduced or used without the consent of EXM

Ce dessin est confidentiel et ne doit pas être reproduit ou utilisé sans le consentement de EXM

**STANDARD FEATURES ARE NOT LISTED IN THIS HOLE TABLE**

**HOLE TABLE - BACK VIEW (CUSTOM FEATURE ONLY)**

CUT-OUT	XDIM	YDIM	DESCRIPTION
1	10.437	0.000	FOOT 885 ESCHMF1
2	0.563	0.000	FOOT 885 ESCHMF1
3	10.437	10.951	FOOT 885 ESCHMF1
4	0.563	10.951	FOOT 885 ESCHMF1
5	10.437	0.344	RIVET NUT M6_FH_CE (Inside)
6	0.563	0.344	RIVET NUT M6_FH_CE (Inside)
7	10.437	10.607	RIVET NUT M6_FH_CE (Inside)
8	0.563	10.607	RIVET NUT M6_FH_CE (Inside)

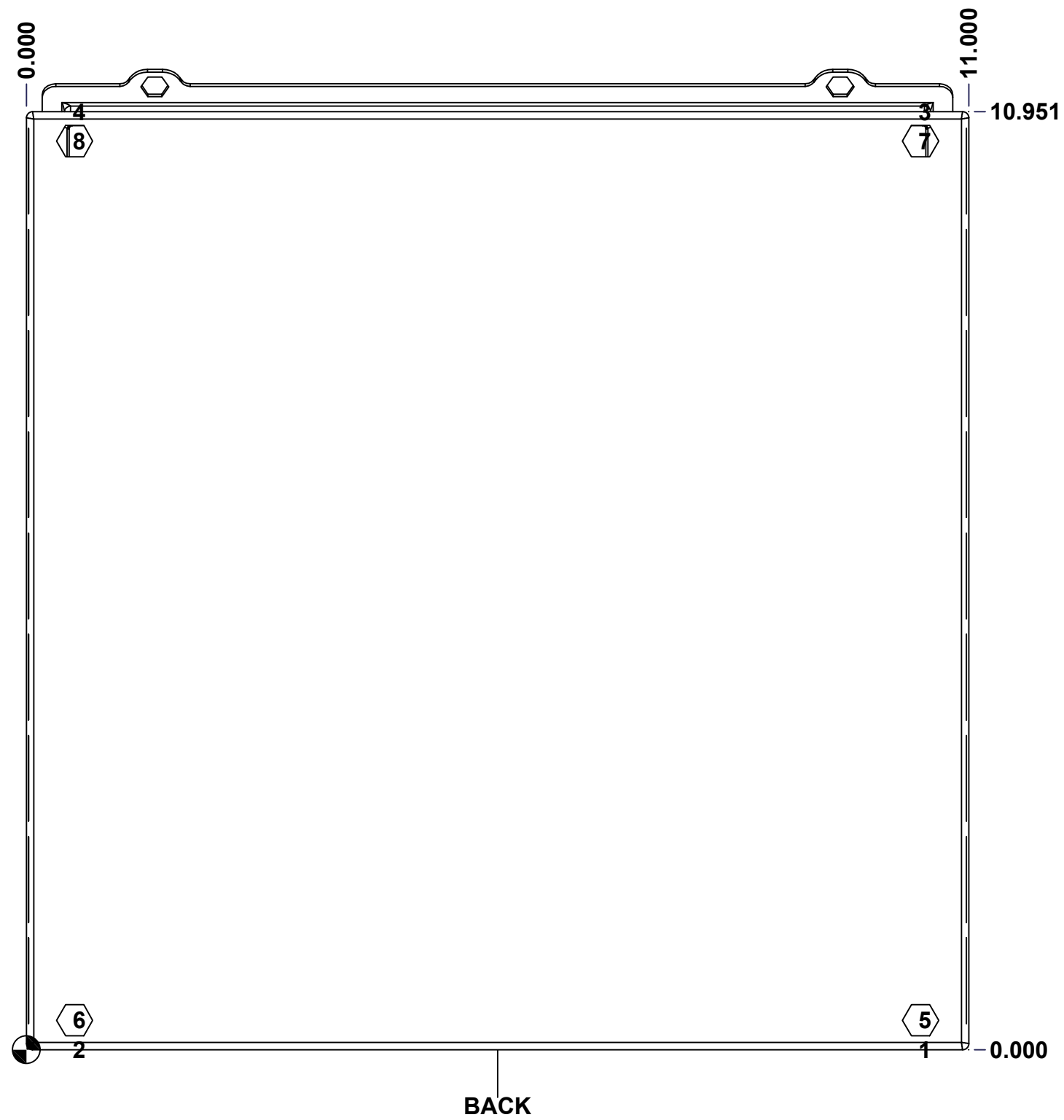

	Description	Status	
	1412SFMN 12.25" x 11" x 9.546" Body	(NULL)	
	Part Number	Rev.	4
	Numéro Pièce	<b>0</b>	9
<b>1412SF111009MNB</b>			

This drawing is confidential and must not be reproduced or used without the consent of EXM

Ce dessin est confidentiel et ne doit pas être reproduit ou utilisé sans le consentement de EXM

<b>STANDARD FEATURES ARE NOT LISTED IN THIS HOLE TABLE</b>			
<b>HOLE TABLE - ANGLE VIEW (CUSTOM FEATURE ONLY)</b>			
CUT-OUT	XDIM	YDIM	DESCRIPTION
1	10.125	0.742	STANDOFF M6 x 10mm (Inside)

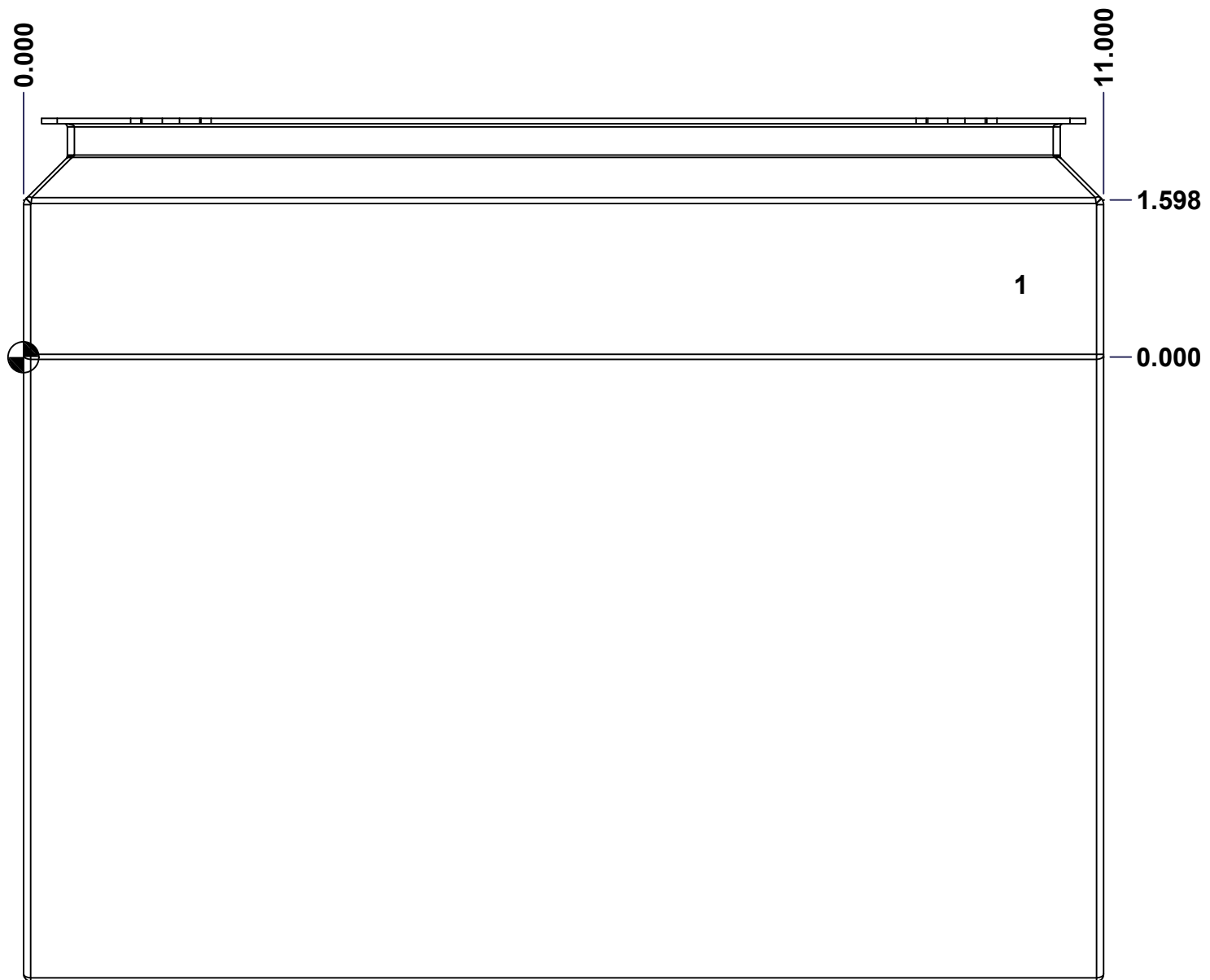

ANGLE

	Description	Status	
	1412SFMN 12.25" x 11" x 9.546" Body	(NULL)	
	Part Number Numéro Pièce	Rev.	5
	<b>1412SF111009MNB</b>	<b>0</b>	9

This drawing is confidential and must not be reproduced or used without the consent of EXM

Ce dessin est confidentiel et ne doit pas être reproduit ou utilisé sans le consentement de EXM

No.	Revisions	Date	By/Par

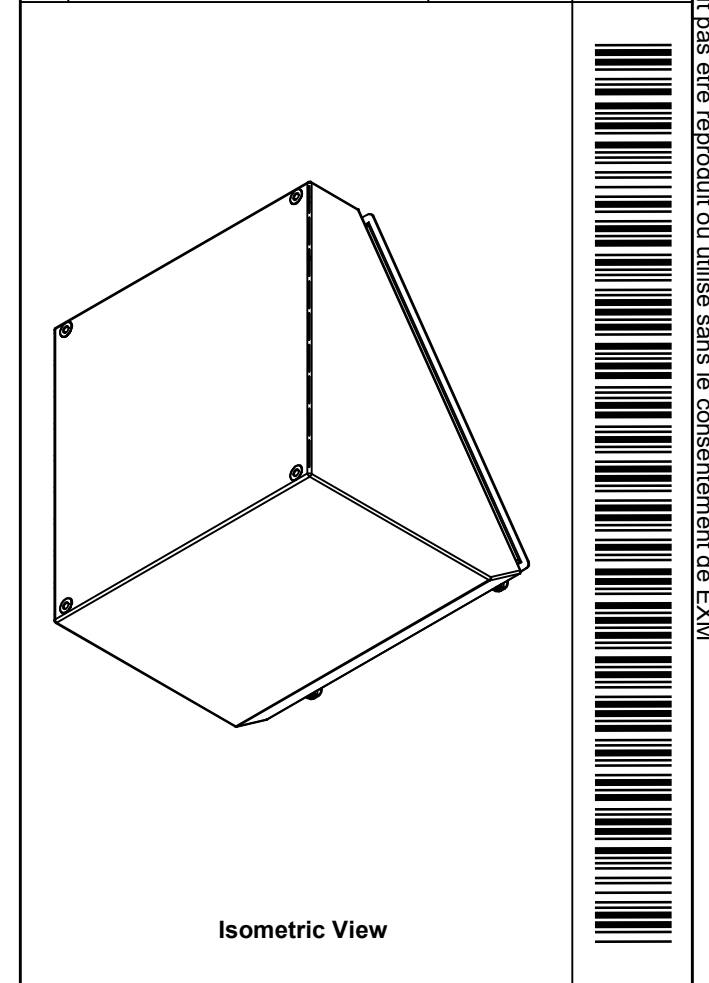

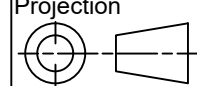
 Tél: (450) 979-4373 Fax: (450) 979-4626 <a href="http://www.exmweb.com">www.exmweb.com</a>		Flatness Aplatissement Max 3.0mm Projection 
Customer Client	Date	
Drawn By / Dessiné Par: BoxCad: BoxCad	Date: 05-Sep-25	
Material / Matière: 16 Ga Cold Rolled A1008 CS Type B (1.4mm)	Color / Couleur: Asa-61 Grey	
Finish / Fini: Smooth		Detail Rev.
Description: 1412SFMN 12.25" x 11" x 9.546" Body		Rev. 6
Part Number / Numéro Pièce: <b>1412SF111009MNB</b>		0 / 9

Qty	Part Number	Rev	Description
4	RIVET_NUT_M6_FH_CE	0	Rivet Nut M6 (Low Profile Close End)
1	STK-Q-08350	5	Standoff M6 x 10mm
1	STK-P-02400S	0	Powder Paint (Asa-61 Grey / Smooth)
4	RIVET_NUT_M5_FH_OE	0	Rivet Nut M5 (Low Profile Open End)
1	1412SF111009MNB-P	0	1412SFMN 12.25" x 11" x 9.546" Body Part
Parts List			

This drawing is confidential and must not be reproduced or used without the consent of EXM

Ce dessin est confidentiel et ne doit pas être reproduit ou utilisé sans le consentement de EXM

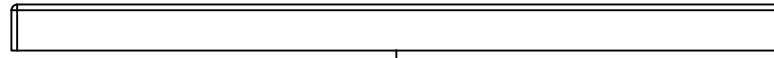

TOP

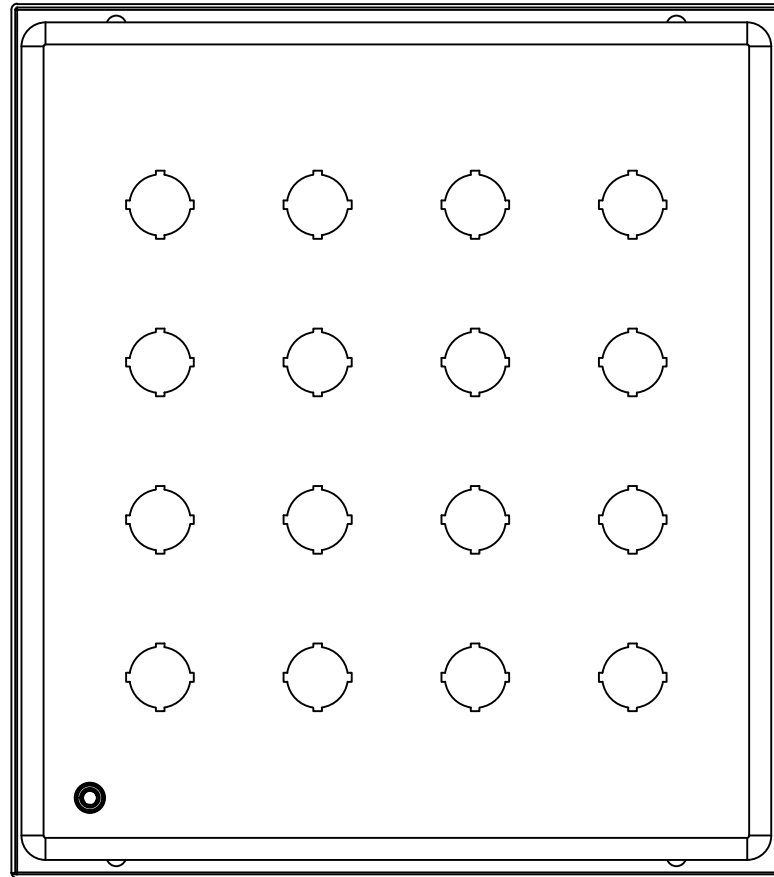

BACK

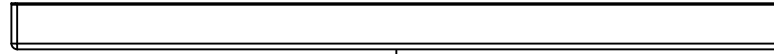

BOTTOM

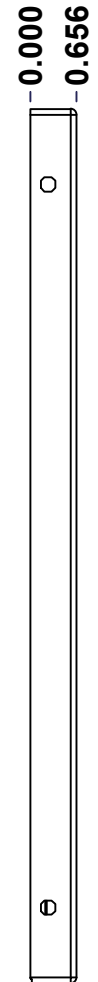

LEFT

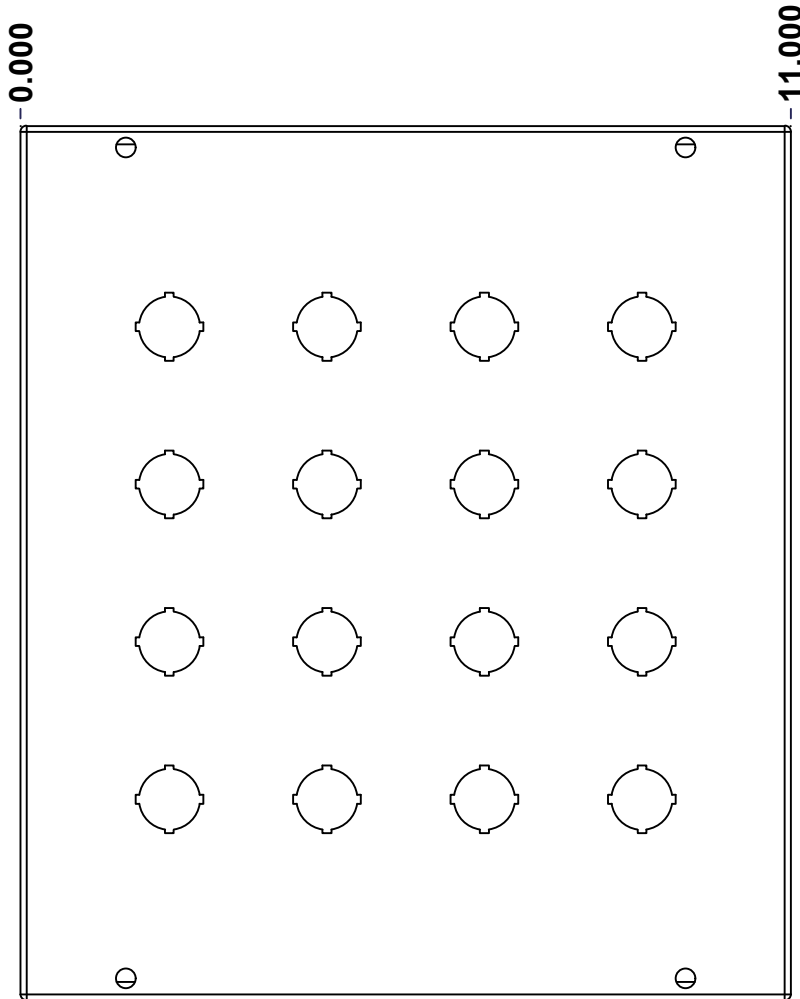

FRONT

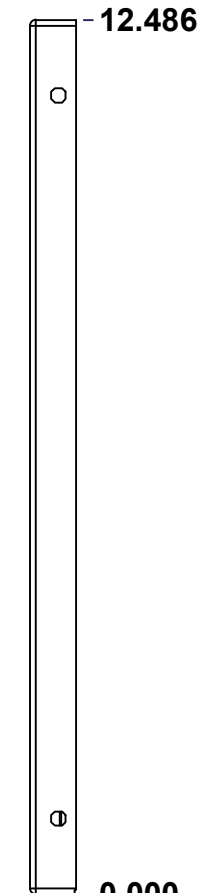

RIGHT

No.	Revisions	Date	By/Par

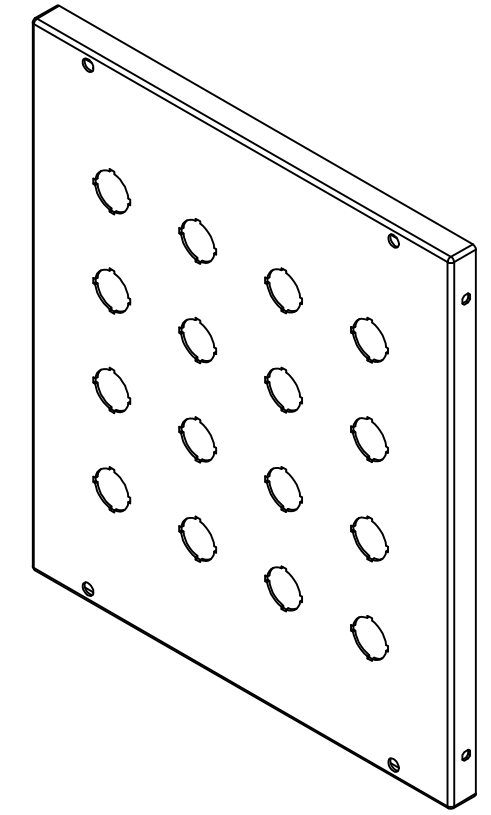

Isometric View



Tél: (450) 979-4373  
 Fax: (450) 979-4626  
[www.exmweb.com](http://www.exmweb.com)

Flatness  
Aplatissement

Max 3.0mm

Projection

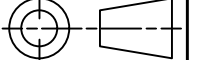

Customer Client	Date
Drawn By / Dessiné Par: BoxCad: BoxCad	Date: 05-Sep-25
Material / Matière: 16 Ga Cold Rolled A1008 CS Type B (1.4mm)	
Color / Couleur: Asa-61 Grey	Finish / Fini: Smooth

Description: 1412SFMN 12.25" x 11" Cover	Detail Rev.
--	-------------

Part Number / Numéro Pièce: 1412SF111009MNC	Rev. 0	7	9
---	--------	---	---

SEE BILL OF MATERIAL ON LAST PAGE

This drawing is confidential and must not be reproduced or used without the consent of EXM

Ce dessin est confidentiel et ne doit pas être reproduit ou utilisé sans le consentement de EXM

**STANDARD FEATURES ARE NOT LISTED IN THIS HOLE TABLE**

**HOLE TABLE - FRONT VIEW (CUSTOM FEATURE ONLY)**

CUT-OUT	XDIM	YDIM	DESCRIPTION
1	8.875	9.618	22.5 mm Miniature Pushbutton
2	6.625	9.618	22.5 mm Miniature Pushbutton
3	4.375	9.618	22.5 mm Miniature Pushbutton
4	2.125	9.618	22.5 mm Miniature Pushbutton
5	8.875	7.368	22.5 mm Miniature Pushbutton
6	6.625	7.368	22.5 mm Miniature Pushbutton
7	4.375	7.368	22.5 mm Miniature Pushbutton
8	2.125	7.368	22.5 mm Miniature Pushbutton
9	8.875	5.118	22.5 mm Miniature Pushbutton
10	6.625	5.118	22.5 mm Miniature Pushbutton
11	4.375	5.118	22.5 mm Miniature Pushbutton
12	2.125	5.118	22.5 mm Miniature Pushbutton
13	8.875	2.868	22.5 mm Miniature Pushbutton
14	6.625	2.868	22.5 mm Miniature Pushbutton
15	4.375	2.868	22.5 mm Miniature Pushbutton
16	2.125	2.868	22.5 mm Miniature Pushbutton
17	9.875	1.145	STANDOFF M6 x 10mm (Inside)

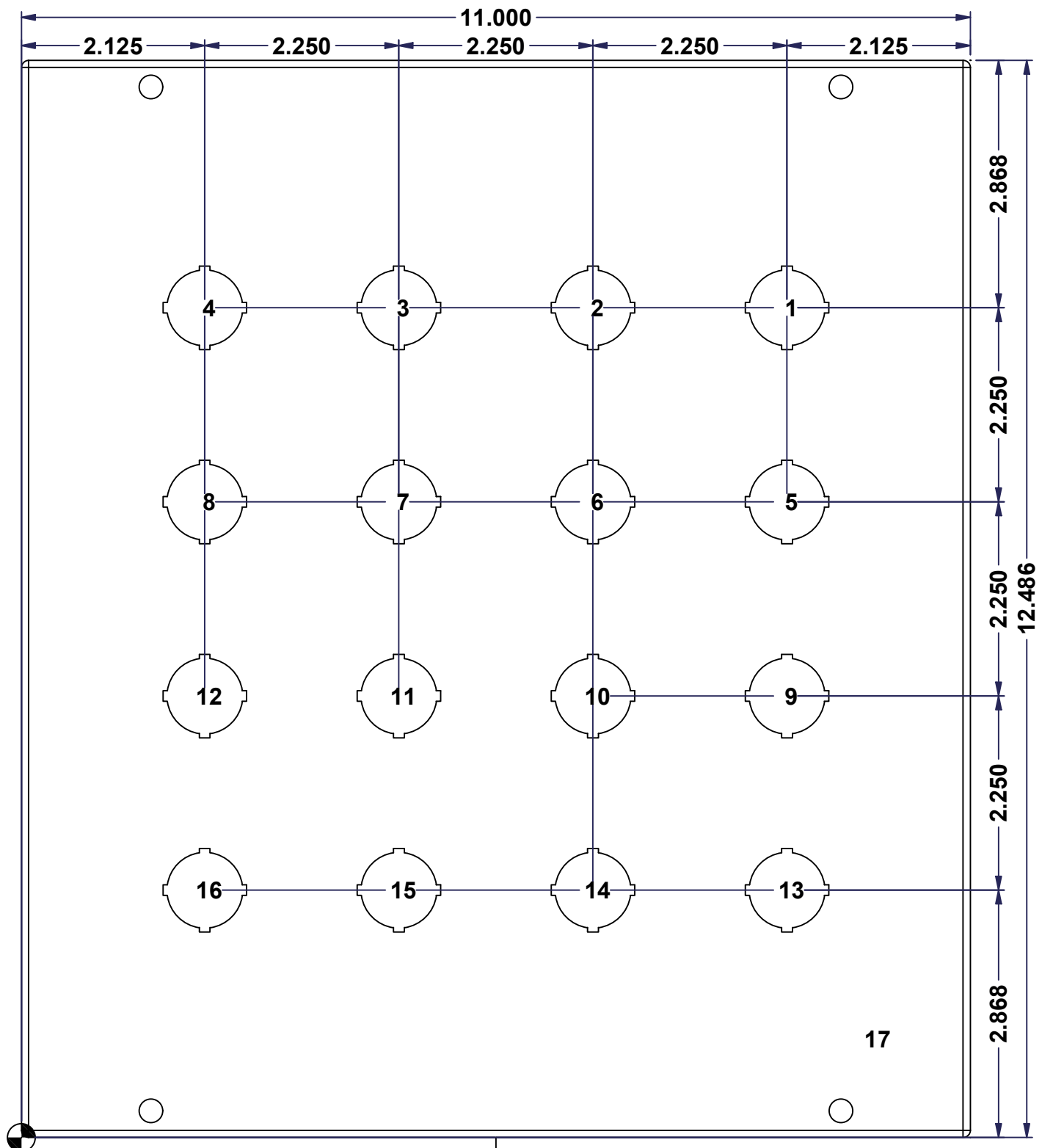

FRONT

	Description	Status
	1412SFMN 12.25" x 11" Cover	(NULL)
	Part Number	Rev.
	Numéro Pièce	8
	<b>1412SF111009MNC</b>	<b>0</b>
		9

This drawing is confidential and must not be reproduced or used without the consent of EXM

Ce dessin est confidentiel et ne doit pas être reproduit ou utilisé sans le consentement de EXM

No.	Revisions	Date	By/Par

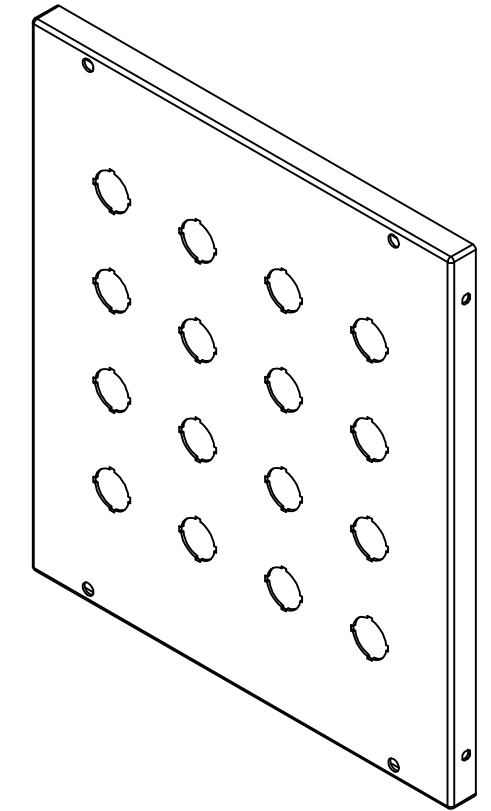

Isometric View

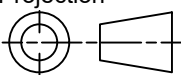

 Tél: (450) 979-4373 Fax: (450) 979-4626 <a href="http://www.exmweb.com">www.exmweb.com</a>		Flatness Aplatissement Max 3.0mm Projection 
Customer Client	Date	
Drawn By Dessiné Par	BoxCad: BoxCad	Date 05-Sep-25
Material Matière	16 Ga Cold Rolled A1008 CS Type B (1.4mm)	
Color Couleur	Asa-61 Grey	Finish Fini Smooth
Description		Detail Rev.
1412SFMN 12.25" x 11" Cover		
Part Number Numéro Pièce	Rev.	9
<b>1412SF111009MNC</b>	<b>0</b>	<b>9</b>

Qty	Part Name	Rev	Description
1	STK-Q-08350	5	Standoff M6 x 10mm
1	1412SF111009MNG	0	1412SF 12.25" x 11" Gasket
1	1412SF111009MNC-P	0	1412SFMN 12.25" x 11" Cover Part
1	STK-P-02400S	0	Powder Paint (Asa-61 Grey / Smooth)
Parts List			