

This drawing is confidential and must not be reproduced or used without the consent of EXM

Ce dessin est confidentiel et ne doit pas être reproduit ou utilisé sans le consentement de EXM

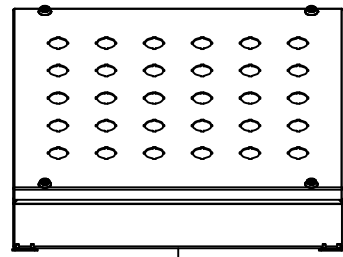

TOP

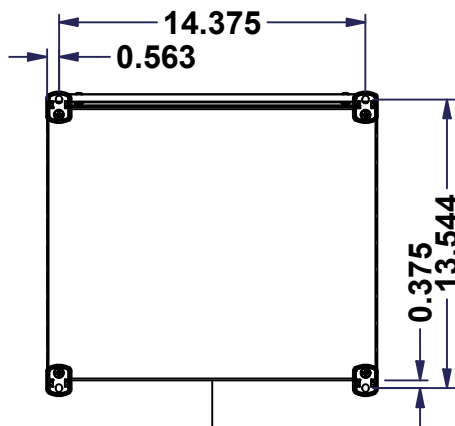

BACK

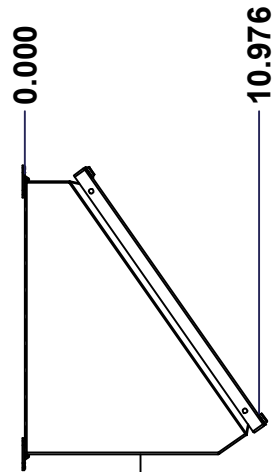

LEFT

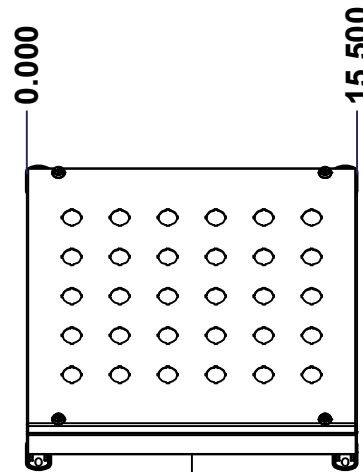

FRONT

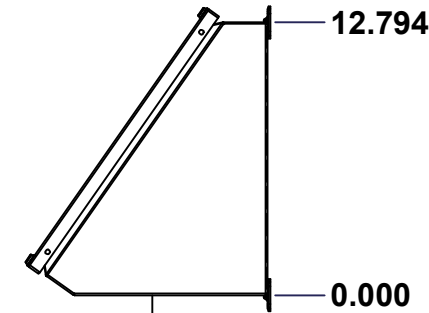

RIGHT

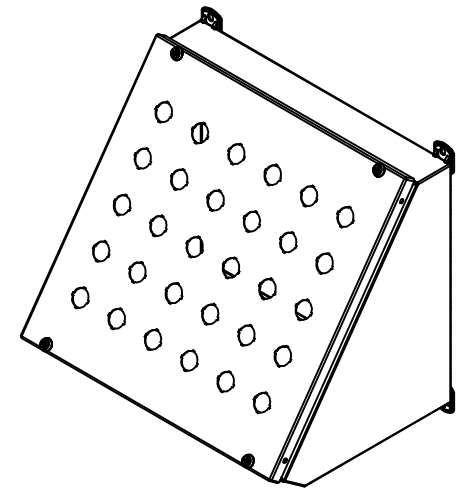

Isometric View



BOTTOM

No.	Revisions	Date	By/Par

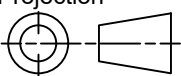
 Tél: (450) 979-4373 Fax: (450) 979-4626 www.exmweb.com		Flatness Aplatissement Max 3.0mm Projection 
Customer Client	Date	
Drawn By Dessiné Par	BoxCad: BoxCad	Date 05-Sep-25
Material Matière	16 Ga Cold Rolled A1008 CS Type B (1.4mm)	
Color Couleur	Asa-61 Grey	Finish Fini Smooth
Description	Detail Rev.	
1412SFMN 14.5" x 15.5" x 10.837" Assembly		
Part Number Numéro Pièce	Rev. 0	1 / 9
1412SF141510MN		

SEE BILL OF MATERIAL ON LAST PAGE

This drawing is confidential and must not be reproduced or used without the consent of EXM

Ce dessin est confidentiel et ne doit pas être reproduit ou utilisé sans le consentement de EXM

NOTE	
ITEM	DESCRIPTION
1	NEMA 4, 12 Enclosure (IP66)
2	C/W Standard ground standoffs on box and cover
3	W/O Standard door stiffener
4	W/O Inner panel
5	W/O Inner panel mounting standoffs
6	C/W 885 ESCHMF1 Mounting Feet (Installed)

No.	Revisions	Date	By/Par

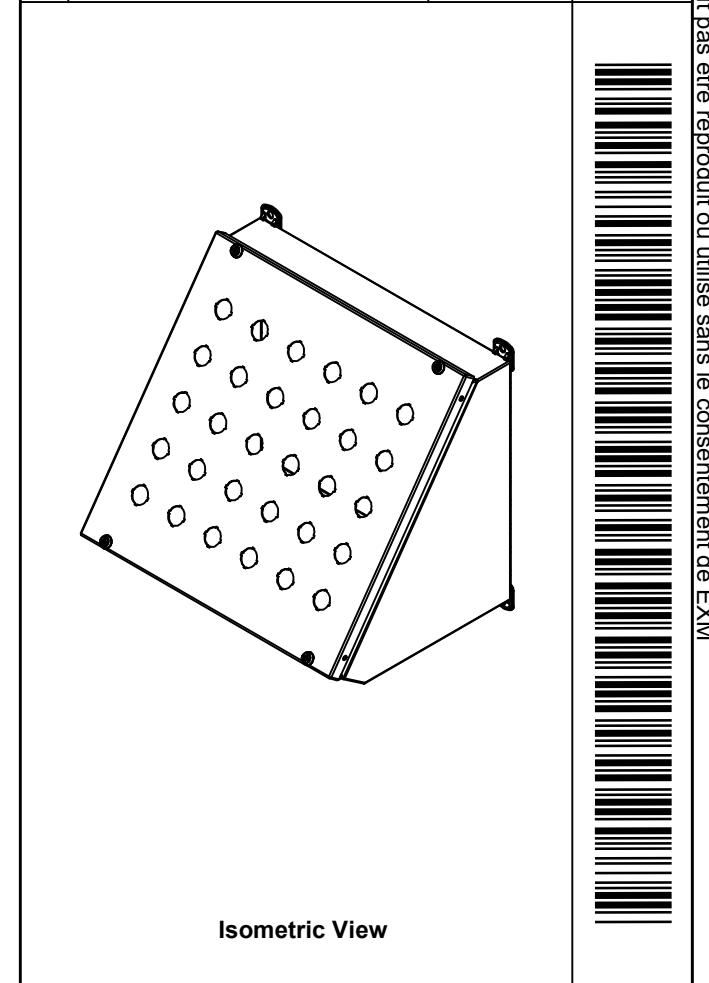

EXM
www.exmweb.com

Tél: (450) 979-4373
Fax: (450) 979-4626

Flatness
Aplatissement
Max 3.0mm

Projection

Customer Client	Date
Drawn By / Dessiné Par: BoxCad: BoxCad	Date: 05-Sep-25
Material / Matière: 16 Ga Cold Rolled A1008 CS Type B (1.4mm)	

Color / Couleur: Asa-61 Grey	Finish / Fini: Smooth
Description: 1412SFMN 14.5" x 15.5" x 10.837" Assembly	Detail Rev.
Part Number / Numéro Pièce: 1412SF141510MN	Rev. 0 / 2

PACKING		
ITEM	QTY	DESCRIPTION
Cardboard sleeve	2	Top and Bottom
Cardboard strip	2	Between back of enclosure and inner panel
Plastic bag	1	To protect cover surface and inside gasket
Plastic strap - Black	2	To Squeeze the 2 cardboard sleeve together
Packaging label	1	White label with product number

Qty	Part Number	Rev	Description
1	885 ESSCHMFQ	0	5412 ESSCH Mounting Feet Accessory Kit
1	STK-K-02920	3	5412 ESSC Accessory Kit
1	1412SF141510MNC	0	1412SFMN 14.5" x 15.5" Cover
1	1412SF141510MNB	0	1412SFMN 14.5" x 15.5" x 10.837" Body

Parts List

This drawing is confidential and must not be reproduced or used without the consent of EXM

Ce dessin est confidentiel et ne doit pas être reproduit ou utilisé sans le consentement de EXM

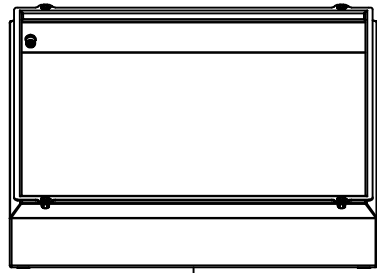

TOP

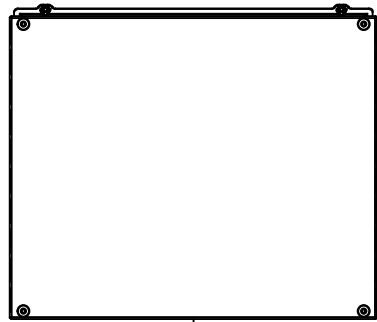

BACK

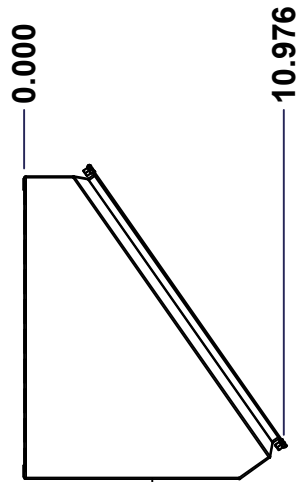

LEFT

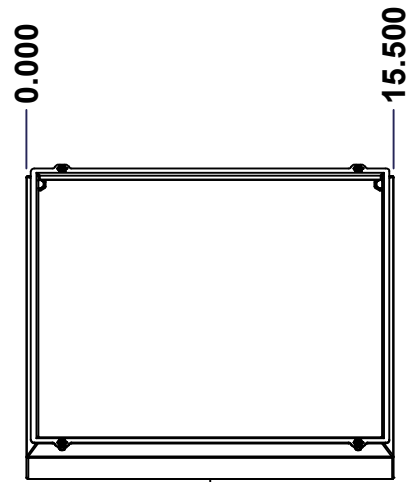

FRONT

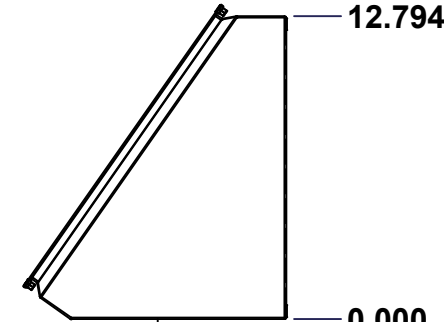

RIGHT



BOTTOM

No.	Revisions	Date	By/Par

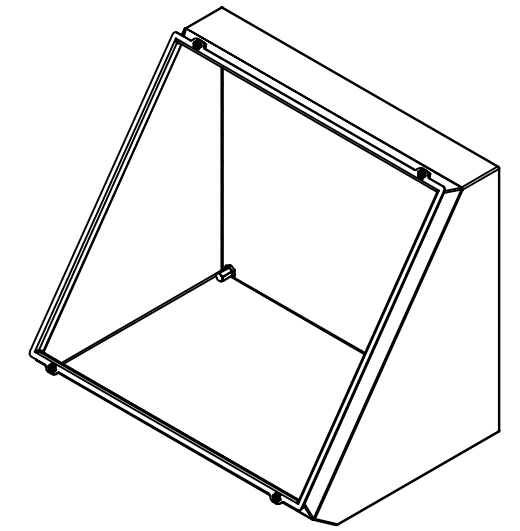

Isometric View



Tél: (450) 979-4373
 Fax: (450) 979-4626
www.exmweb.com

Flatness
Aplatissement

Max 3.0mm

Projection

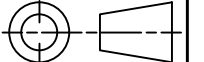

Customer Client	Date
Drawn By Dessiné Par BoxCad: BoxCad	Date 05-Sep-25
Material Matière 16 Ga Cold Rolled A1008 CS Type B (1.4mm)	
Color Couleur Asa-61 Grey	Finish Fini Smooth
Description 1412SFMN 14.5" x 15.5" x 10.837" Body	Detail Rev.
Part Number Numéro Pièce 1412SF141510MNB	Rev. 0
	3 9

SEE BILL OF MATERIAL ON LAST PAGE

This drawing is confidential and must not be reproduced or used without the consent of EXM

Ce dessin est confidentiel et ne doit pas être reproduit ou utilisé sans le consentement de EXM

STANDARD FEATURES ARE NOT LISTED IN THIS HOLE TABLE

HOLE TABLE - BACK VIEW (CUSTOM FEATURE ONLY)

CUT-OUT	XDIM	YDIM	DESCRIPTION
1	14.937	0.000	FOOT 885 ESCHMF1
2	0.563	0.000	FOOT 885 ESCHMF1
3	14.937	12.794	FOOT 885 ESCHMF1
4	0.563	12.794	FOOT 885 ESCHMF1
5	14.937	0.344	RIVET NUT M6_FH_CE (Inside)
6	0.563	0.344	RIVET NUT M6_FH_CE (Inside)
7	14.937	12.450	RIVET NUT M6_FH_CE (Inside)
8	0.563	12.450	RIVET NUT M6_FH_CE (Inside)

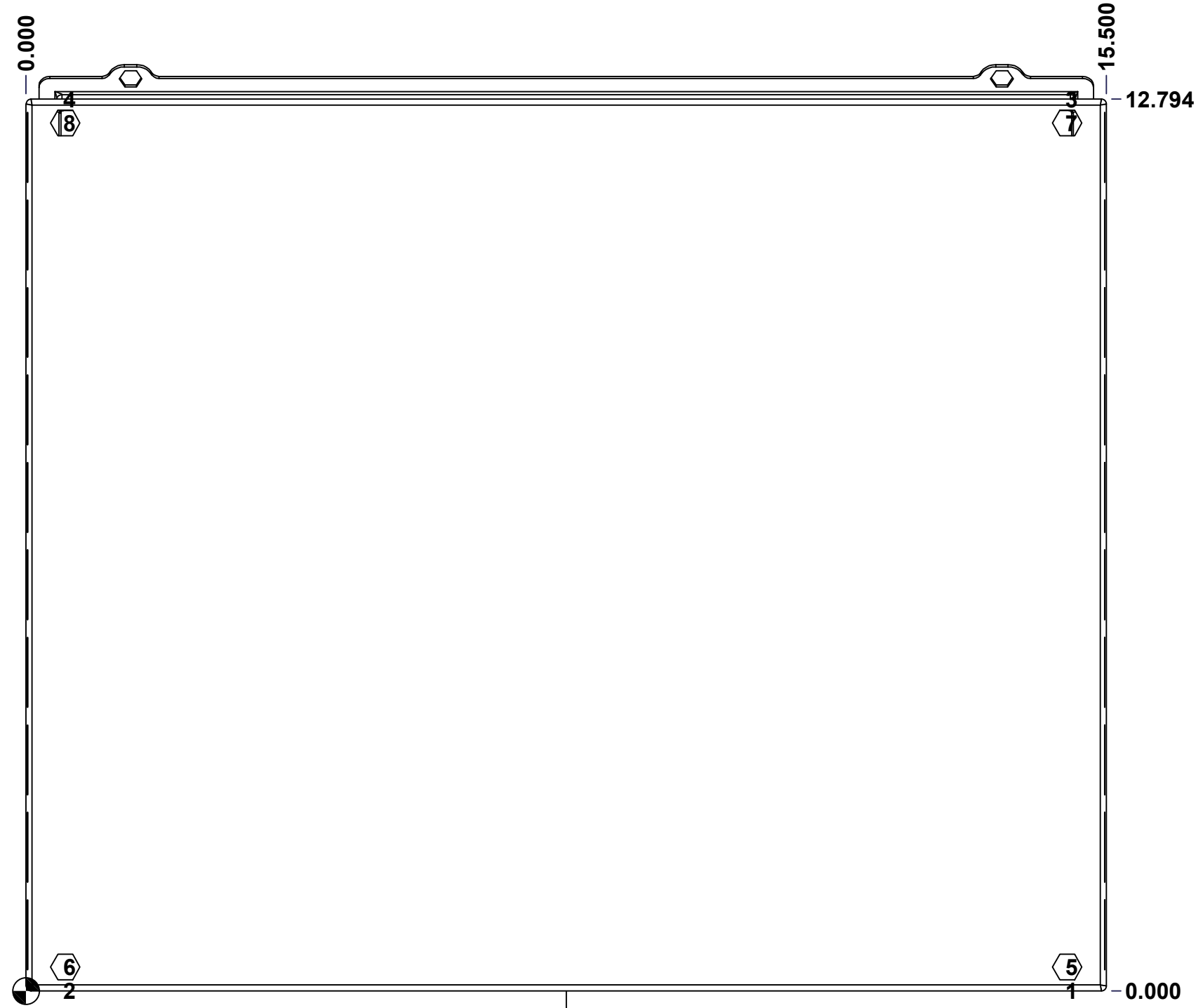

BACK

	Description	Status	
	1412SFMN 14.5" x 15.5" x 10.837" Body	(NULL)	
	Part Number	Rev.	4
	Numéro Pièce	0	9
1412SF141510MNB			

This drawing is confidential and must not be reproduced or used without the consent of EXM

Ce dessin est confidentiel et ne doit pas être reproduit ou utilisé sans le consentement de EXM

STANDARD FEATURES ARE NOT LISTED IN THIS HOLE TABLE			
HOLE TABLE - ANGLE VIEW (CUSTOM FEATURE ONLY)			
CUT-OUT	XDIM	YDIM	DESCRIPTION
1	14.625	0.742	STANDOFF M6 x 10mm (Inside)





	Description	Status	
	1412SFMN 14.5" x 15.5" x 10.837" Body	(NULL)	
	Part Number Numéro Pièce	Rev.	5
	1412SF141510MNB	0	9

This drawing is confidential and must not be reproduced or used without the consent of EXM

Ce dessin est confidentiel et ne doit pas être reproduit ou utilisé sans le consentement de EXM

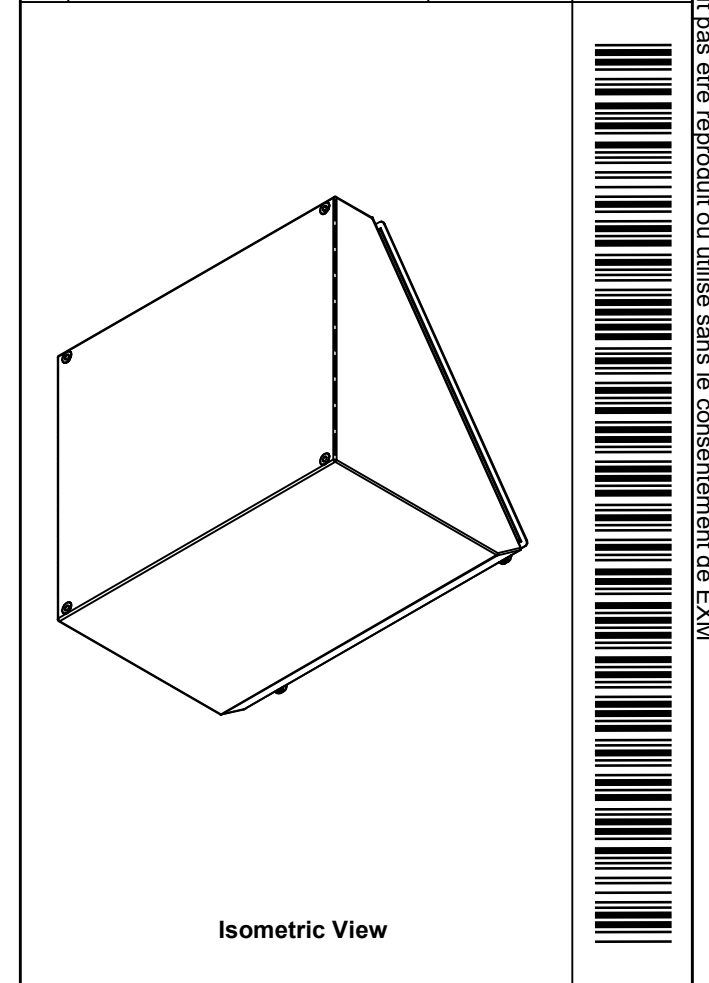
No.	Revisions	Date	By/Par

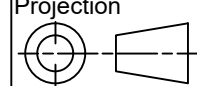

 Tél: (450) 979-4373 Fax: (450) 979-4626 www.exmweb.com		Flatness Aplatissement Max 3.0mm Projection 
Customer Client	Date	
Drawn By Dessiné Par	BoxCad: BoxCad	Date 05-Sep-25
Material Matière	16 Ga Cold Rolled A1008 CS Type B (1.4mm)	
Color Couleur	Asa-61 Grey	Finish Fini Smooth
Description		Detail Rev.
1412SFMN 14.5" x 15.5" x 10.837" Body		
Part Number Numéro Pièce	Rev.	6
1412SF141510MNB	0	9

Qty	Part Number	Rev	Description
4	RIVET_NUT_M6_FH_CE	0	Rivet Nut M6 (Low Profile Close End)
1	STK-Q-08350	5	Standoff M6 x 10mm
1	STK-P-02400S	0	Powder Paint (Asa-61 Grey / Smooth)
4	RIVET_NUT_M5_FH_OE	0	Rivet Nut M5 (Low Profile Open End)
1	1412SF141510MNB-P	0	1412SFMN 14.5" x 15.5" x 10.837" Body Part
Parts List			

This drawing is confidential and must not be reproduced or used without the consent of EXM

Ce dessin est confidentiel et ne doit pas être reproduit ou utilisé sans le consentement de EXM

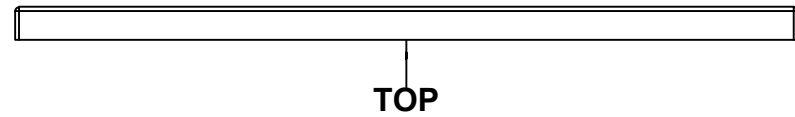

TOP

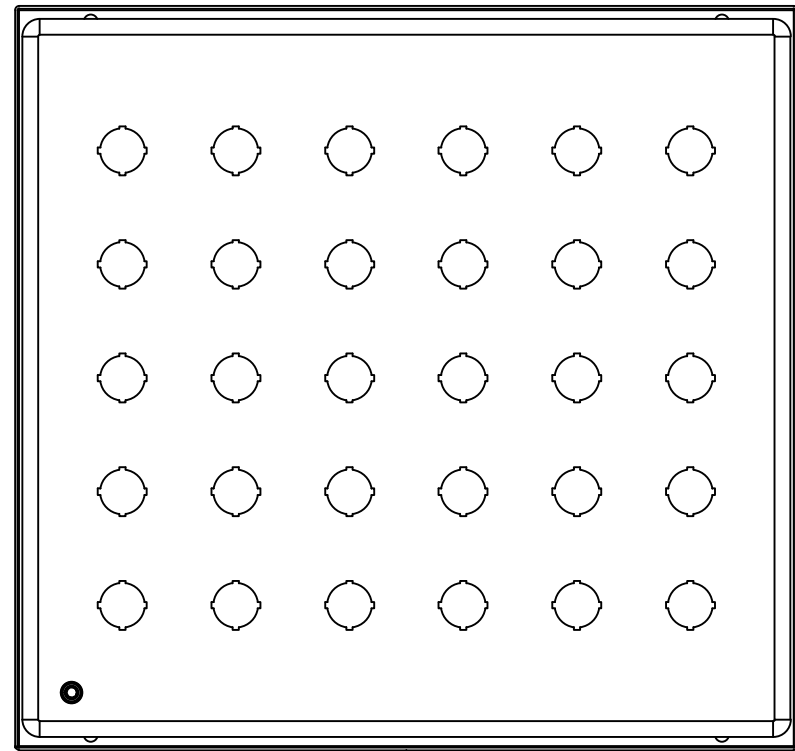

BACK

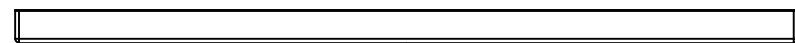

BOTTOM

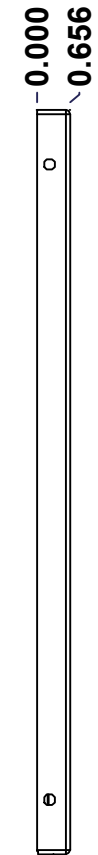

LEFT

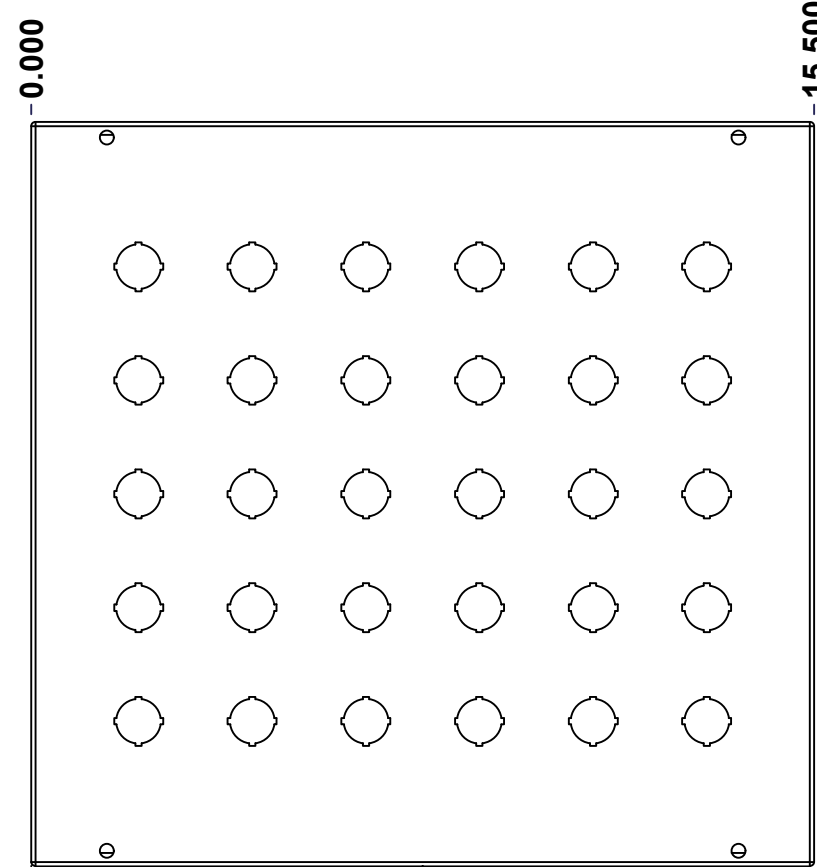

FRONT

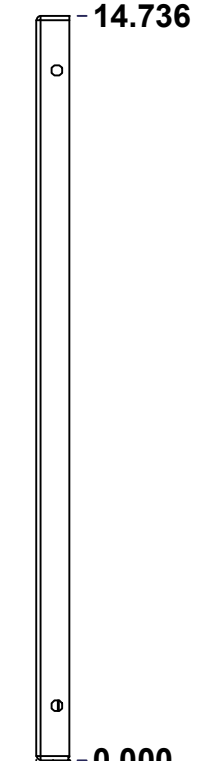

RIGHT

No.	Revisions	Date	By/Par

Isometric View

<p>Tél: (450) 979-4373 Fax: (450) 979-4626 www.exmweb.com</p>		Flatness Aplatissement
		Max 3.0mm
Customer Client		Date
Drawn By / Dessiné Par: BoxCad: BoxCad		Date: 05-Sep-25
Material / Matière: 16 Ga Cold Rolled A1008 CS Type B (1.4mm)		
Color / Couleur: Asa-61 Grey	Finish / Fini: Smooth	
Description: 1412SFMN 14.5" x 15.5" Cover		Detail Rev.
Part Number / Numéro Pièce: 1412SF141510MNC		Rev. 7 0

SEE BILL OF MATERIAL ON LAST PAGE

This drawing is confidential and must not be reproduced or used without the consent of EXM

Ce dessin est confidentiel et ne doit pas être reproduit ou utilisé sans le consentement de EXM

STANDARD FEATURES ARE NOT LISTED IN THIS HOLE TABLE			
HOLE TABLE - FRONT VIEW (CUSTOM FEATURE ONLY)			
CUT-OUT	XDIM	YDIM	DESCRIPTION
1	13.375	11.868	22.5 mm Miniature Pushbutton
2	11.125	11.868	22.5 mm Miniature Pushbutton
3	8.875	11.868	22.5 mm Miniature Pushbutton
4	6.625	11.868	22.5 mm Miniature Pushbutton
5	4.375	11.868	22.5 mm Miniature Pushbutton
6	2.125	11.868	22.5 mm Miniature Pushbutton
7	13.375	9.618	22.5 mm Miniature Pushbutton
8	11.125	9.618	22.5 mm Miniature Pushbutton
9	8.875	9.618	22.5 mm Miniature Pushbutton
10	6.625	9.618	22.5 mm Miniature Pushbutton
11	4.375	9.618	22.5 mm Miniature Pushbutton
12	2.125	9.618	22.5 mm Miniature Pushbutton
13	13.375	7.368	22.5 mm Miniature Pushbutton
14	11.125	7.368	22.5 mm Miniature Pushbutton
15	8.875	7.368	22.5 mm Miniature Pushbutton
16	6.625	7.368	22.5 mm Miniature Pushbutton
17	4.375	7.368	22.5 mm Miniature Pushbutton
18	2.125	7.368	22.5 mm Miniature Pushbutton
19	13.375	5.118	22.5 mm Miniature Pushbutton
20	11.125	5.118	22.5 mm Miniature Pushbutton
21	8.875	5.118	22.5 mm Miniature Pushbutton
22	6.625	5.118	22.5 mm Miniature Pushbutton
23	4.375	5.118	22.5 mm Miniature Pushbutton
24	2.125	5.118	22.5 mm Miniature Pushbutton
25	13.375	2.868	22.5 mm Miniature Pushbutton
26	11.125	2.868	22.5 mm Miniature Pushbutton
27	8.875	2.868	22.5 mm Miniature Pushbutton
28	6.625	2.868	22.5 mm Miniature Pushbutton
29	4.375	2.868	22.5 mm Miniature Pushbutton
30	2.125	2.868	22.5 mm Miniature Pushbutton
31	14.375	1.145	STANDOFF M6 x 10mm (Inside)

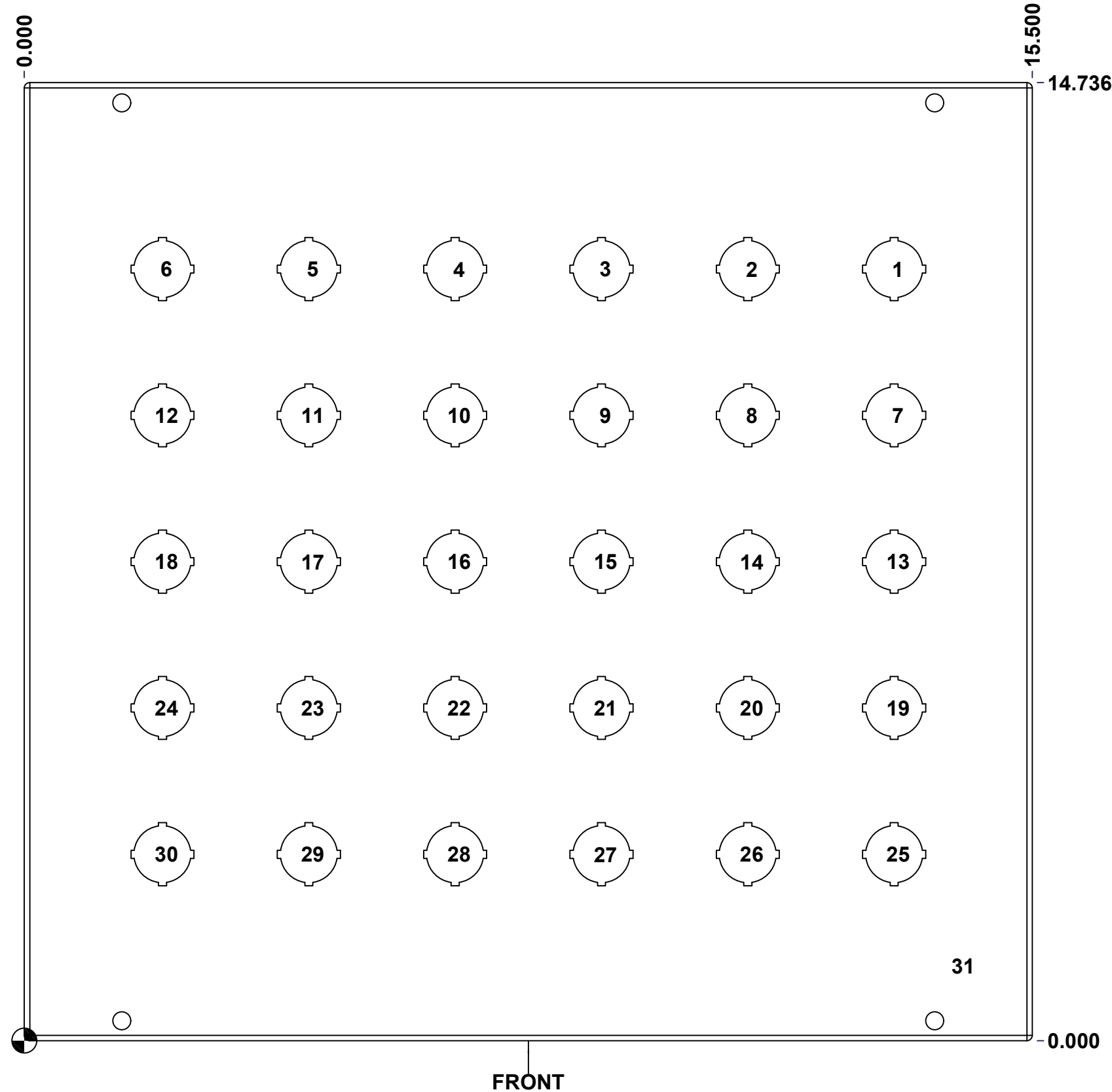



	Description	Status	
	1412SFMN 14.5" x 15.5" Cover	(NULL)	
	Part Number	Rev.	8
	Numéro Pièce	0	9
	1412SF141510MNC		

This drawing is confidential and must not be reproduced or used without the consent of EXM

Ce dessin est confidentiel et ne doit pas être reproduit ou utilisé sans le consentement de EXM

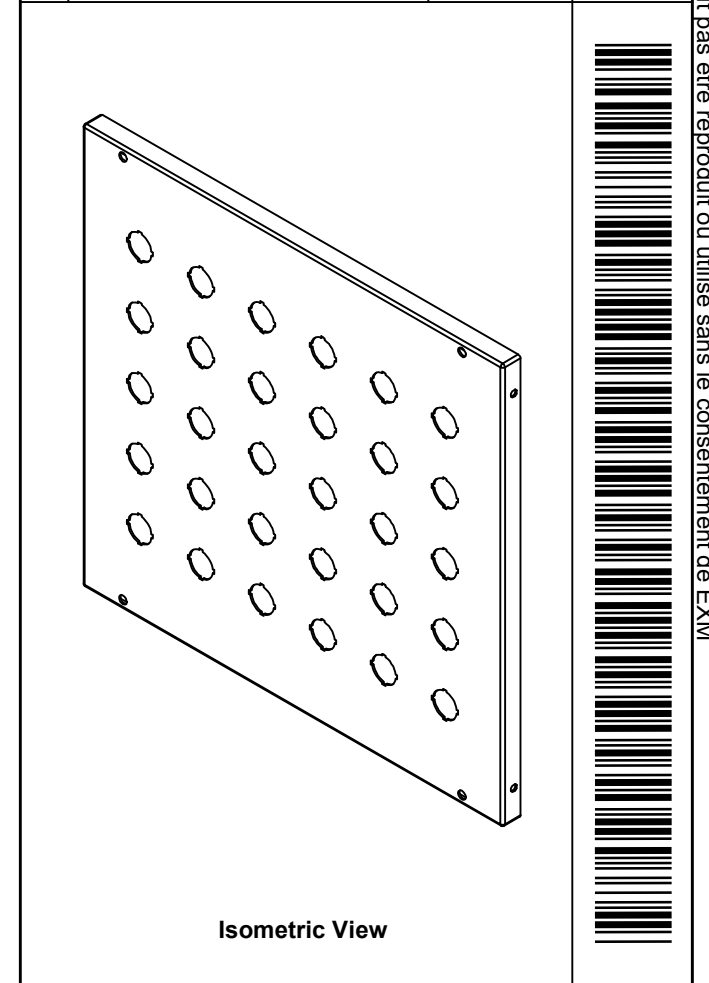
No.	Revisions	Date	By/Par

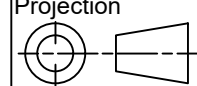

 Tél: (450) 979-4373 Fax: (450) 979-4626 www.exmweb.com		Flatness Aplatissement Max 3.0mm Projection 
Customer Client	Date	
Drawn By / Dessiné Par: BoxCad: BoxCad	Date: 05-Sep-25	
Material / Matière: 16 Ga Cold Rolled A1008 CS Type B (1.4mm)		
Color / Couleur: Asa-61 Grey	Finish / Fini: Smooth	
Description: 1412SFMN 14.5" x 15.5" Cover		Detail Rev.
Part Number / Numéro Pièce: 1412SF141510MNC		Rev. 9
		0 / 9

Qty	Part Name	Rev	Description
1	STK-Q-08350	5	Standoff M6 x 10mm
1	1412SF141510MNG	0	1412SF 14.5" x 15.5" Gasket
1	1412SF141510MNC-P	0	1412SFMN 14.5" x 15.5" Cover Part
1	STK-P-02400S	0	Powder Paint (Asa-61 Grey / Smooth)
Parts List			