

This drawing is confidential and must not be reproduced or used without the consent of EXM

Ce dessin est confidentiel et ne doit pas être reproduit ou utilisé sans le consentement de EXM

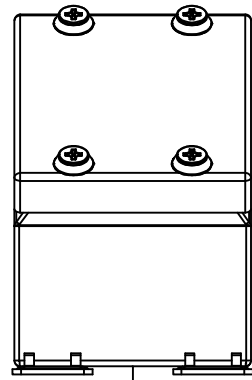

TOP

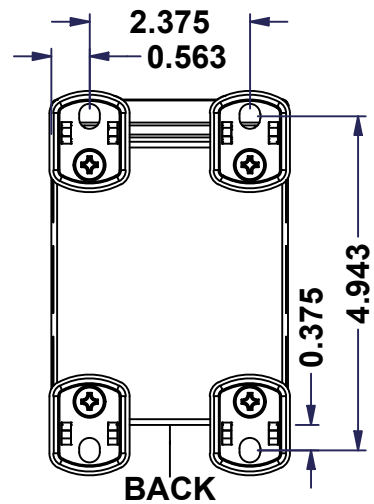

BACK

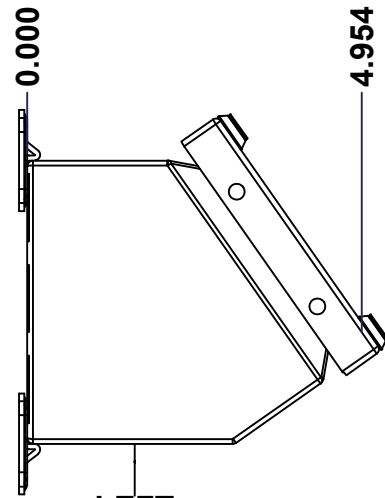

LEFT

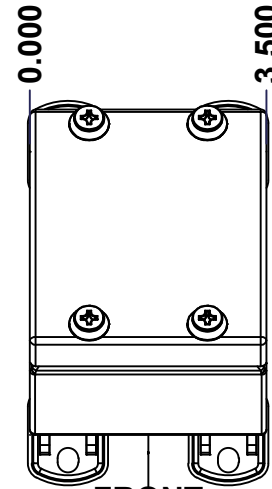

FRONT

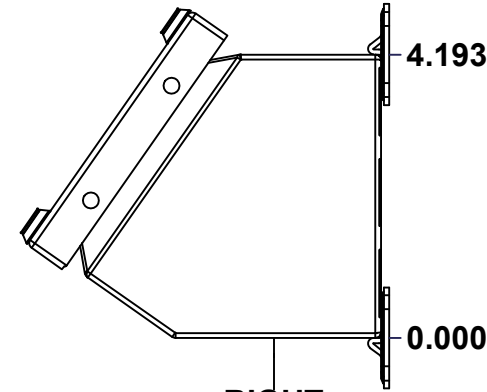

RIGHT

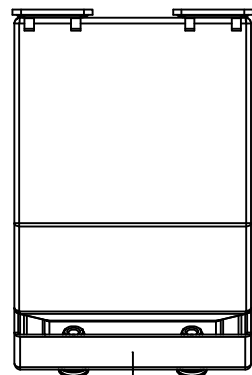

BOTTOM

| No. | Revisions | Date | By/Par |
|-----|-----------|------|--------|
| | | | |
| | | | |
| | | | |
| | | | |

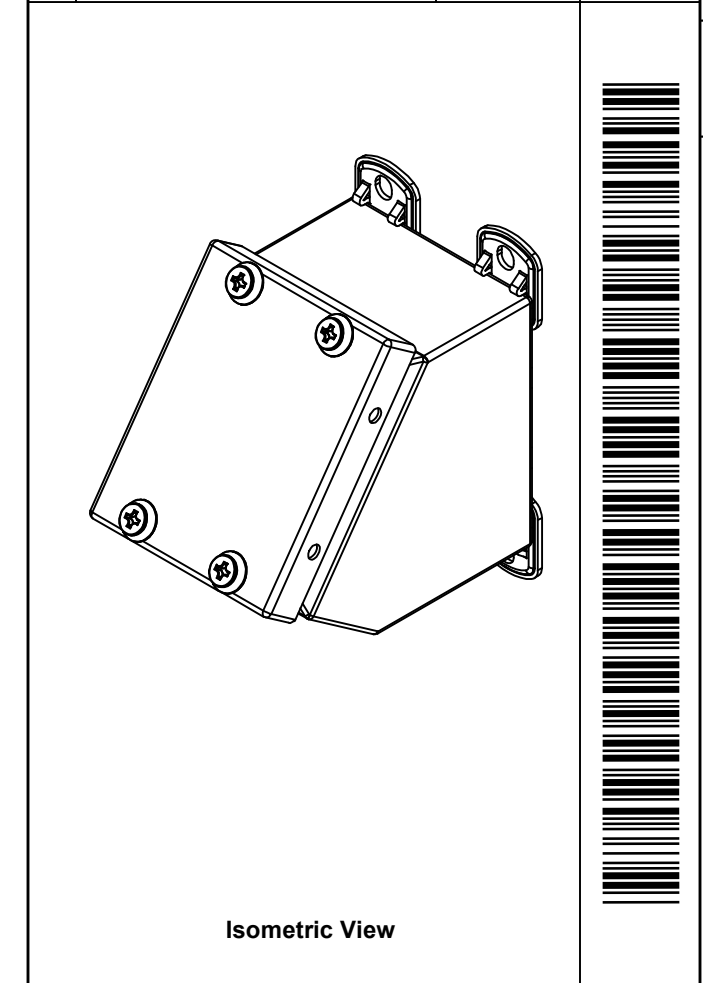

Isometric View

| | | |
|--|---|--|
| Tél: (450) 979-4373 Fax: (450) 979-4626 www.exmweb.com | | Flatness Aplatissement Max 3.0mm Projection |
| Customer Client | Date | |
| Drawn By Dessiné Par | BoxCad: BoxCad | Date 11-Feb-22 |
| Material Matière | 16 Ga Cold Rolled A1008 CS Type B (1.4mm) | |
| Color Couleur | Asa-61 Grey | Finish Fini Smooth |
| Description | 1412SFC 4" x 3.5" x 4.814" Assembly | |
| Part Number Numéro Pièce | 1412SFC030304 | Detail Rev. Rev. 1 0 / 8 |

SEE BILL OF MATERIAL ON LAST PAGE

This drawing is confidential and must not be reproduced or used without the consent of EXM

Ce dessin est confidentiel et ne doit pas être reproduit ou utilisé sans le consentement de EXM

| NOTE | |
|------|---|
| ITEM | DESCRIPTION |
| 1 | NEMA 4, 12 Enclosure (IP66) |
| 2 | C/W Standard ground standoffs on box only |
| 3 | W/O Standard door stiffener |
| 4 | W/O Inner panel |
| 5 | W/O Inner panel mounting standoffs |
| 6 | C/W 885 ESCHMF1 Mounting Feet (Installed) |

| No. | Revisions | Date | By/Par |
|-----|-----------|------|--------|
| | | | |
| | | | |
| | | | |
| | | | |
| | | | |
| | | | |

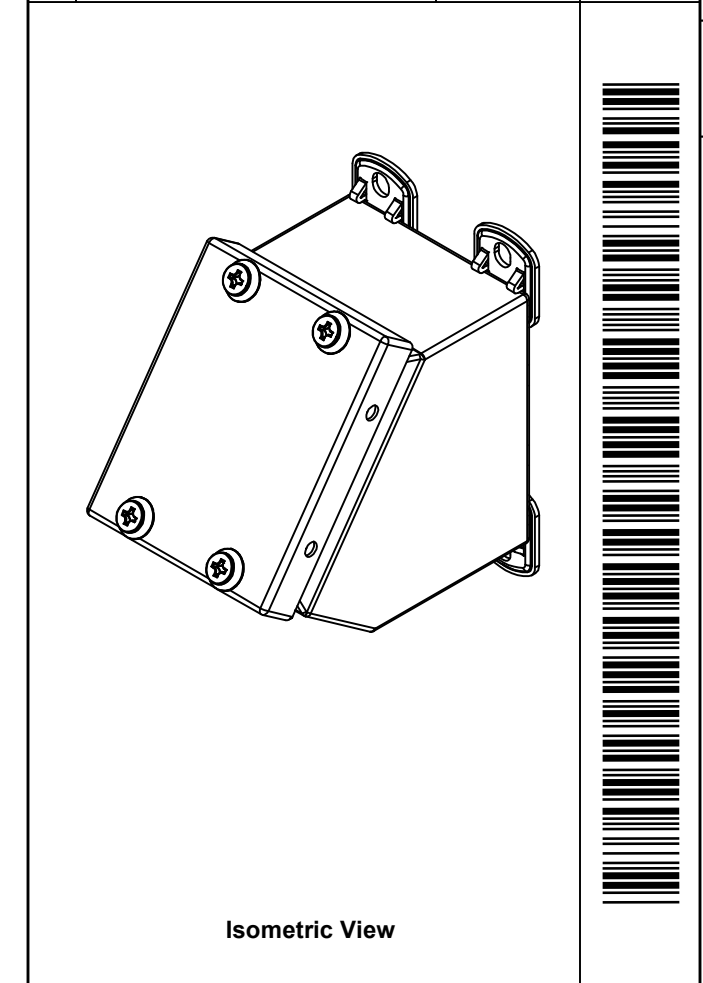

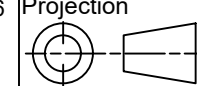
| | |
|--|---|
|  Tél: (450) 979-4373 Fax: (450) 979-4626 www.exmweb.com | Flatness Aplatissement Max 3.0mm |
| | Projection  |
| Customer Client | Date |
| Drawn By Dessiné Par BoxCad: BoxCad | Date 11-Feb-22 |
| Material Matière 16 Ga Cold Rolled A1008 CS Type B (1.4mm) | |
| Color Couleur Asa-61 Grey | Finish Fini Smooth |

| PACKING | | |
|-----------------------|-----|--|
| ITEM | QTY | DESCRIPTION |
| Cardboard sleeve | 2 | Top and Bottom |
| Cardboard strip | 2 | Between back of enclosure and inner panel |
| Plastic bag | 1 | To protect cover surface and inside gasket |
| Plastic strap - Black | 2 | To Squeeze the 2 cardboard sleeve together |
| Packaging label | 1 | White label with product number |

| Qty | Part Number | Rev | Description |
|------------|----------------|-----|--|
| 1 | 885 ESSCHMFQ | 0 | 5412 ESSCH Mounting Feet Accessory Kit |
| 1 | STK-K-02920 | 3 | 5412 ESSC Accessory Kit |
| 1 | 1412SFC030304C | 0 | 1412SFC 4" x 3.5" Cover |
| 1 | 1412SFC030304B | 0 | 1412SFC 4" x 3.5" x 4.814" Body |
| Parts List | | | |

| | |
|-------------------------------------|------------------|
| Description | Detail Rev. |
| 1412SFC 4" x 3.5" x 4.814" Assembly | |
| Part Number Numéro Pièce | Rev. |
| 1412SFC030304 | 0 / 2 / 8 |

This drawing is confidential and must not be reproduced or used without the consent of EXM

Ce dessin est confidentiel et ne doit pas être reproduit ou utilisé sans le consentement de EXM

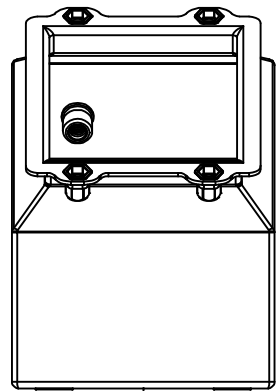

TOP

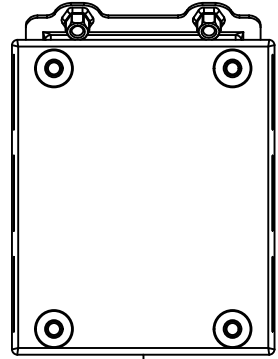

BACK

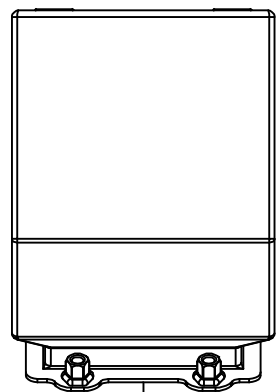

BOTTOM

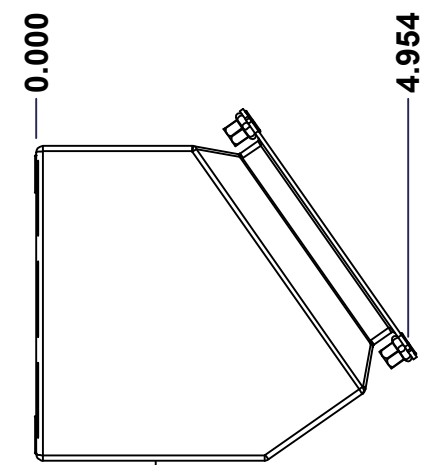

LEFT

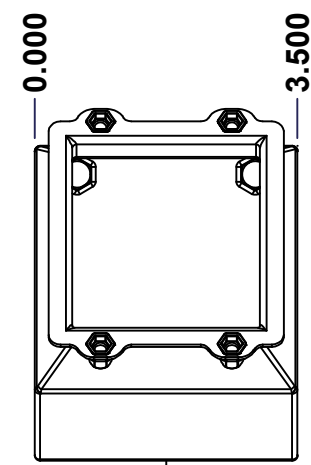

FRONT

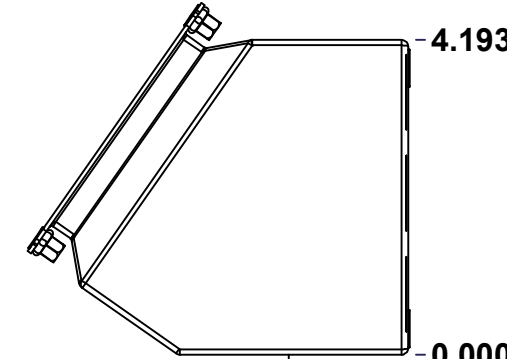

RIGHT

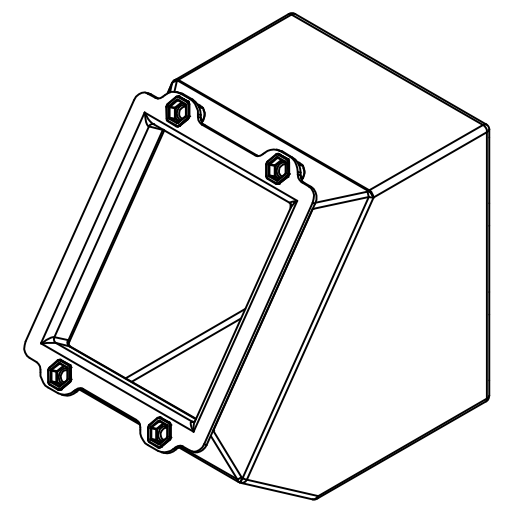

Isometric View

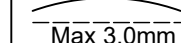
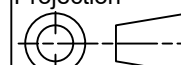

| No. | Revisions | Date | By/Par |
|-----|-----------|------|--------|
| | | | |
| | | | |
| | | | |
| | | | |

| | | |
|--|---|--|
|  Tél: (450) 979-4373 Fax: (450) 979-4626 www.exmweb.com | | Flatness Aplatissement  Max 3.0mm Projection  |
| Customer Client | Date | |
| Drawn By Dessiné Par | BoxCad: BoxCad | Date 11-Feb-22 |
| Material Matière | 16 Ga Cold Rolled A1008 CS Type B (1.4mm) | |
| Color Couleur | Asa-61 Grey | Finish Fini Smooth |
| Description | Detail Rev. | |
| 1412SFC 4" x 3.5" x 4.814" Body | | |
| Part Number Numéro Pièce | Rev. | 3 |
| 1412SFC030304B | 0 | 8 |

SEE BILL OF MATERIAL ON LAST PAGE

This drawing is confidential and must not be reproduced or used without the consent of EXM

Ce dessin est confidentiel et ne doit pas être reproduit ou utilisé sans le consentement de EXM

STANDARD FEATURES ARE NOT LISTED IN THIS HOLE TABLE

HOLE TABLE - BACK VIEW (CUSTOM FEATURE ONLY)

| CUT-OUT | XDIM | YDIM | DESCRIPTION |
|---------|-------|-------|-----------------------------|
| 1 | 2.937 | 0.000 | FOOT 885 ESCHMF1 |
| 2 | 0.563 | 0.000 | FOOT 885 ESCHMF1 |
| 3 | 2.937 | 4.161 | FOOT 885 ESCHMF1 |
| 4 | 0.563 | 4.161 | FOOT 885 ESCHMF1 |
| 5 | 2.937 | 0.344 | RIVET NUT M6_FH_CE (Inside) |
| 6 | 0.563 | 0.344 | RIVET NUT M6_FH_CE (Inside) |
| 7 | 2.937 | 3.817 | RIVET NUT M6_FH_CE (Inside) |
| 8 | 0.563 | 3.817 | RIVET NUT M6_FH_CE (Inside) |

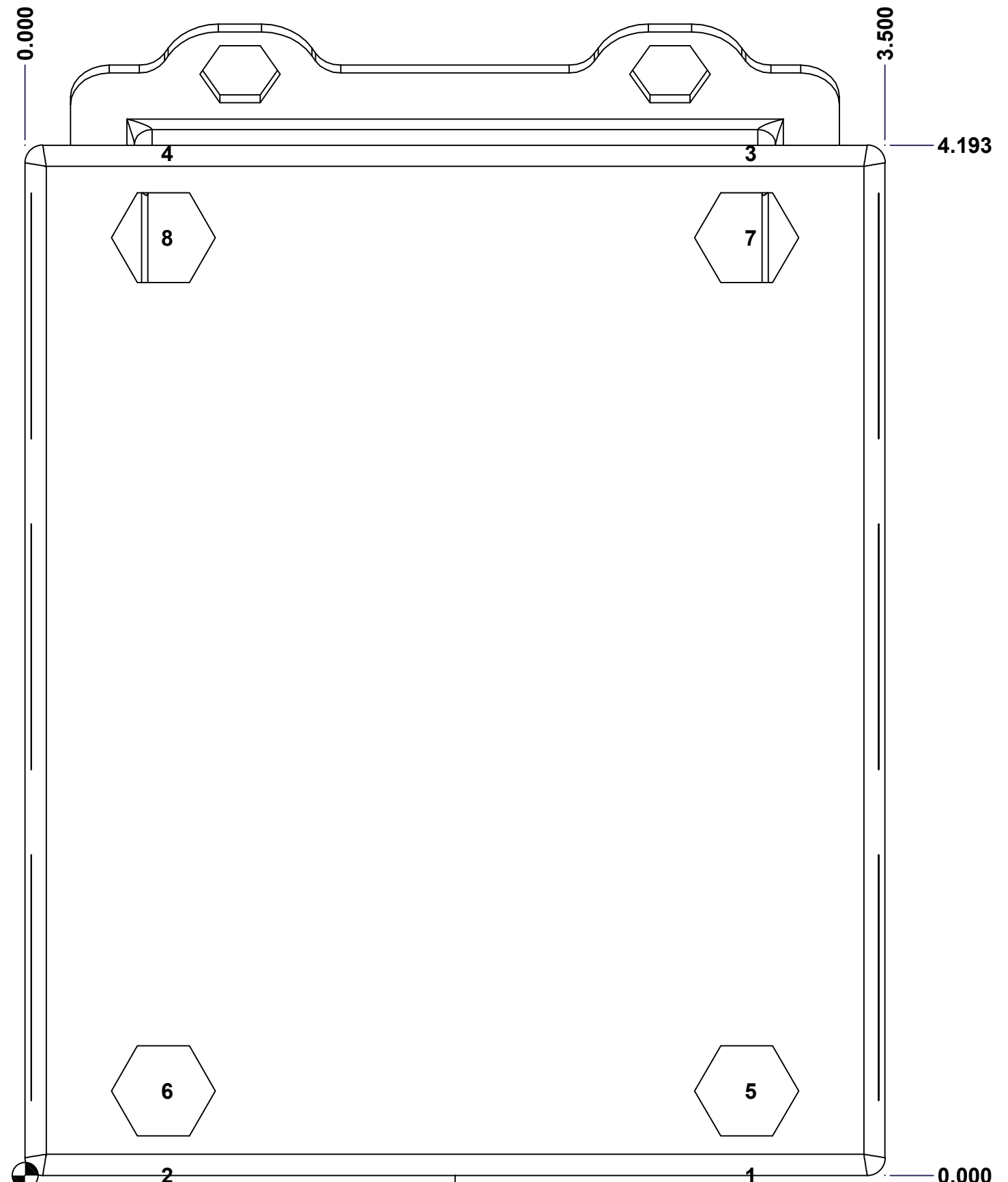

BACK

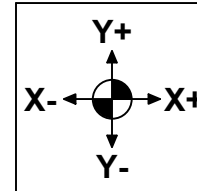

| | | |
|--------------------------------|--|----------|
| Description | | Status |
| 1412SF 4" x 3.5" x 4.814" Body | | (NULL) |
| Part Number Numéro Pièce | | Rev. |
| 1412SFC030304B | | 0 |

| | |
|---|---|
| 4 | 8 |
| 0 | |

This drawing is confidential and must not be reproduced or used without the consent of EXM

Ce dessin est confidentiel et ne doit pas être reproduit ou utilisé sans le consentement de EXM

| STANDARD FEATURES ARE NOT LISTED IN THIS HOLE TABLE | | | |
|--|-------|-------|-----------------------------|
| HOLE TABLE - ANGLE VIEW (CUSTOM FEATURE ONLY) | | | |
| CUT-OUT | XDIM | YDIM | DESCRIPTION |
| 1 | 2.625 | 0.742 | STANDOFF M6 x 10mm (Inside) |

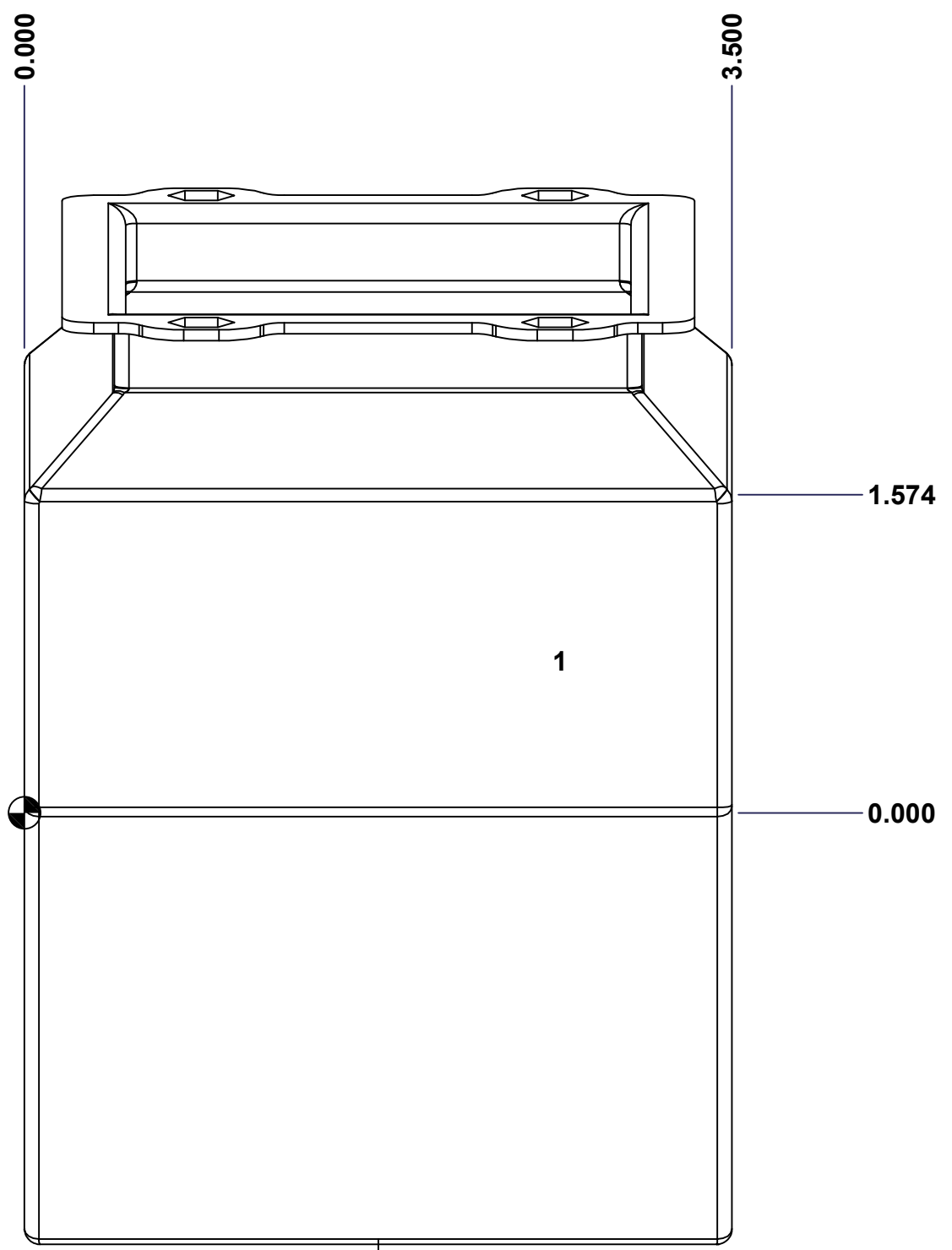

ANGLE

| | | | |
|--|--------------------------------|----------|---|
| | Description | Status | |
| | 1412SF 4" x 3.5" x 4.814" Body | (NULL) | |
| | Part Number Numéro Pièce | Rev. | 5 |
| | 1412SFC030304B | 0 | 8 |

This drawing is confidential and must not be reproduced or used without the consent of EXM

Ce dessin est confidentiel et ne doit pas être reproduit ou utilisé sans le consentement de EXM

| No. | Revisions | Date | By/Par |
|-----|-----------|------|--------|
| | | | |
| | | | |
| | | | |
| | | | |
| | | | |

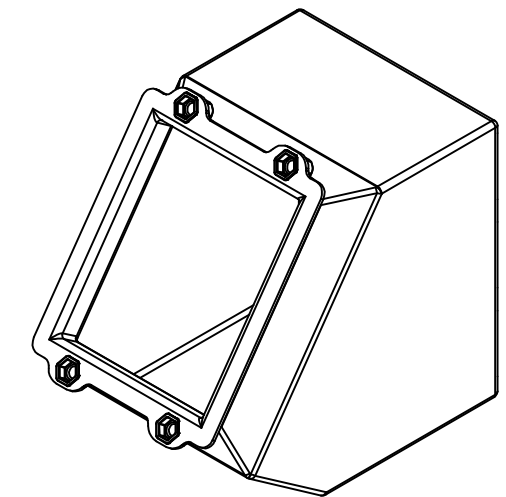

Isometric View

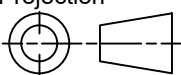

| | | |
|--|---|---|
|  Tél: (450) 979-4373 Fax: (450) 979-4626 www.exmweb.com | Flatness Aplatissement | Max 3.0mm |
| | Projection |  |
| Customer Client | Date | |
| Drawn By Dessiné Par | BoxCad: BoxCad | Date 11-Feb-22 |
| Material Matière | 16 Ga Cold Rolled A1008 CS Type B (1.4mm) | |
| Color Couleur | Asa-61 Grey | Finish Fini Smooth |
| Description | Detail Rev. | |
| 1412SFC 4" x 3.5" x 4.814" Body | | |
| Part Number Numéro Pièce | Rev. | 6 |
| 1412SFC030304B | 0 | 8 |

| Qty | Part_Number | Rev | Description |
|------------|--------------------|-----|--------------------------------------|
| 4 | RIVET_NUT_M6_FH_CE | 0 | Rivet Nut M6 (Low Profile Close End) |
| 1 | STK-Q-08350 | 5 | Standoff M6 x 10mm |
| 1 | STK-P-02400S | 0 | Powder Paint (Asa-61 Grey / Smooth) |
| 1 | 1412SFC030304B-P | 0 | 1412SF 4" x 3.5" x 4.814" Body Part |
| 4 | RIVET_NUT_M5_FH_OE | 0 | Rivet Nut M5 (Low Profile Open End) |
| Parts List | | | |

This drawing is confidential and must not be reproduced or used without the consent of EXM

Ce dessin est confidentiel et ne doit pas être reproduit ou utilisé sans le consentement de EXM

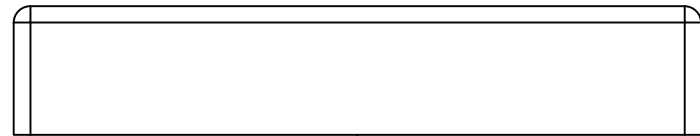

TOP

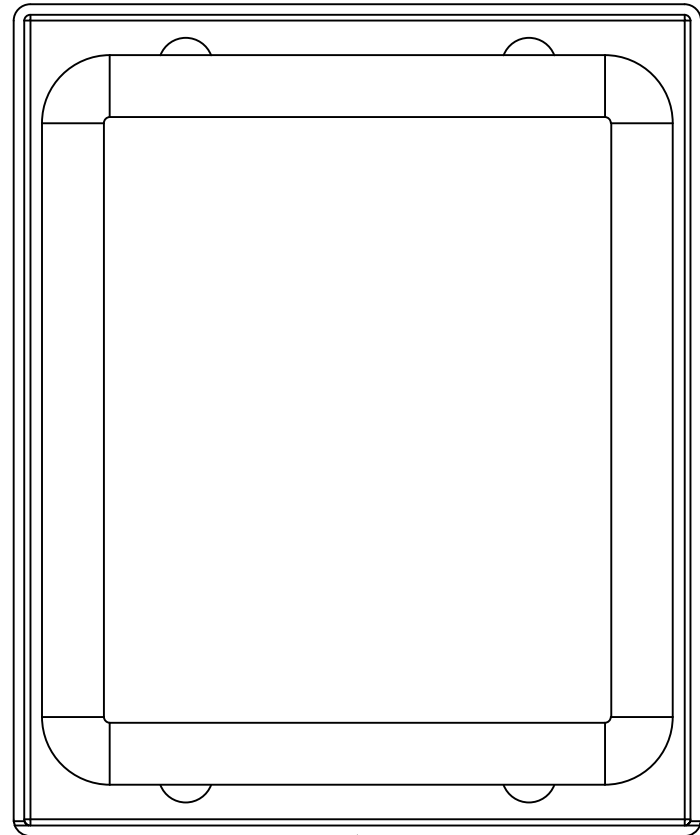

BACK

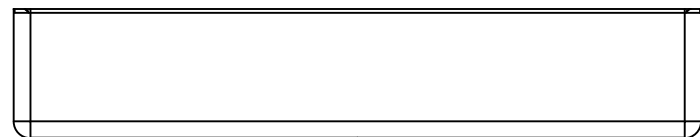

BOTTOM

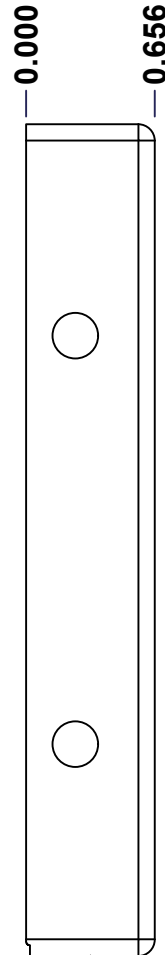

LEFT

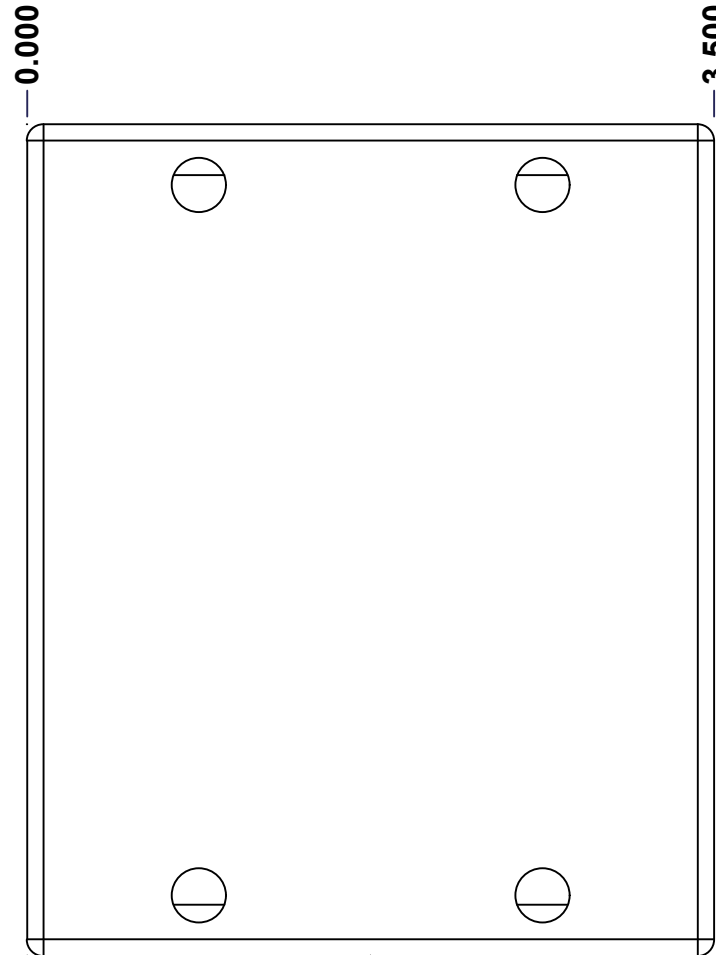



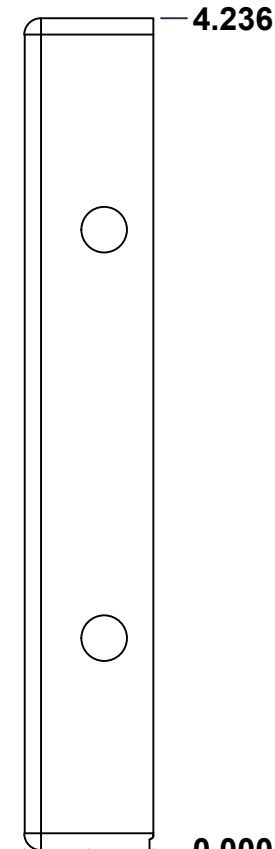

FRONT

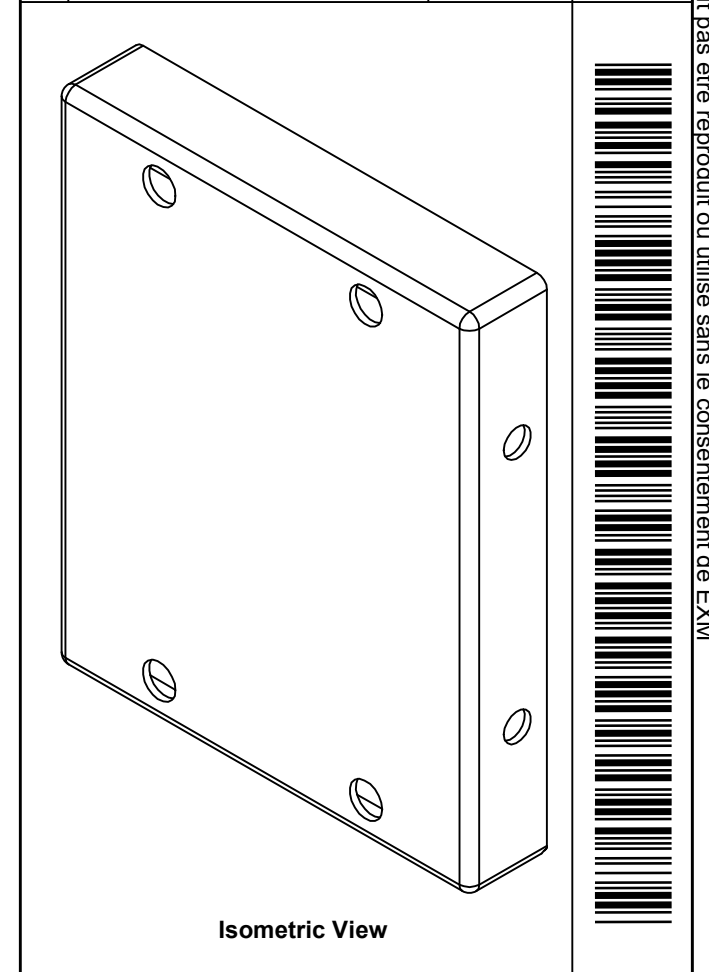

RIGHT

| No. | Revisions | Date | By/Par |
|-----|-----------|------|--------|
| | | | |
| | | | |
| | | | |
| | | | |
| | | | |

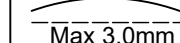

| | | | |
|--|--|--|-------------|
|  Tél: (450) 979-4373 Fax: (450) 979-4626 www.exmweb.com | | Flatness Aplatissement  Max 3.0mm | |
| | | Projection  | |
| Customer Client | | Date | |
| Drawn By / Dessiné Par: BoxCad: BoxCad | | Date: 11-Feb-22 | |
| Material / Matière: 16 Ga Cold Rolled A1008 CS Type B (1.4mm) | | | |
| Color / Couleur: Asa-61 Grey | | Finish / Fini: Smooth | |
| Description: 1412SFC 4" x 3.5" Cover | | | Detail Rev. |
| Part Number / Numéro Pièce: 1412SFC030304C | | Rev.: | 7 / 8 |

SEE BILL OF MATERIAL ON LAST PAGE

This drawing is confidential and must not be reproduced or used without the consent of EXM

Ce dessin est confidentiel et ne doit pas être reproduit ou utilisé sans le consentement de EXM

| No. | Revisions | Date | By/Par |
|-----|-----------|------|--------|
| | | | |
| | | | |
| | | | |
| | | | |
| | | | |

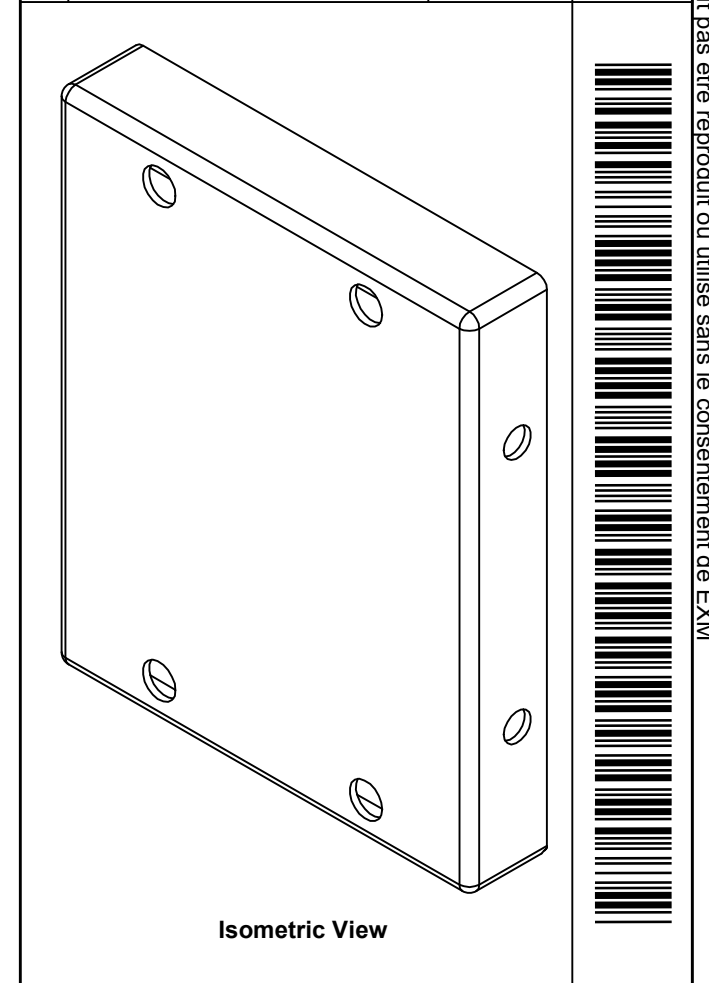

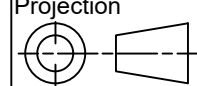
| | | |
|--|---|---|
|  Tél: (450) 979-4373 Fax: (450) 979-4626 www.exmweb.com | | Flatness Aplatissement Max 3.0mm Projection  |
| Customer Client | Date | |
| Drawn By Dessiné Par | BoxCad: BoxCad | Date 11-Feb-22 |
| Material Matière | 16 Ga Cold Rolled A1008 CS Type B (1.4mm) | |
| Color Couleur | Asa-61 Grey | Finish Fini Smooth |
| Description | | Detail Rev. |
| 1412SFC 4" x 3.5" Cover | | |
| Part Number Numéro Pièce | | Rev. 8 |
| 1412SFC030304C | | 0 / 8 |

| Qty | Part Name | Rev | Description |
|------------|------------------|-----|-------------------------------------|
| 1 | 1412SFC030304G | 0 | 1412SF 4" x 3.5" Gasket |
| 1 | 1412SFC030304C-P | 0 | 1412SF 4" x 3.5" Cover Part |
| 1 | STK-P-02400S | 0 | Powder Paint (Asa-61 Grey / Smooth) |
| Parts List | | | |