

This drawing is confidential and must not be reproduced or used without the consent of EXM

Ce dessin est confidentiel et ne doit pas être reproduit ou utilisé sans le consentement de EXM

APPROVED FOR PRODUCTION
APPROUVÉ POUR PRODUCTION
 SIGNATURE: _____
 NAME / NOM: _____
 DATE: _____
 Please visit: www.boxcadexm.com

No.	Revisions	Date	By/Par

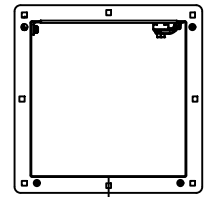

TOP

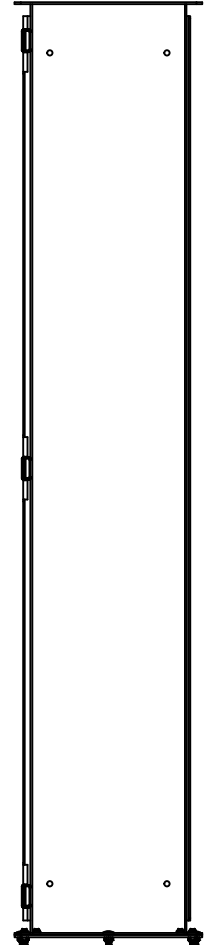

BACK

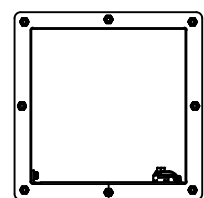

BOTTOM

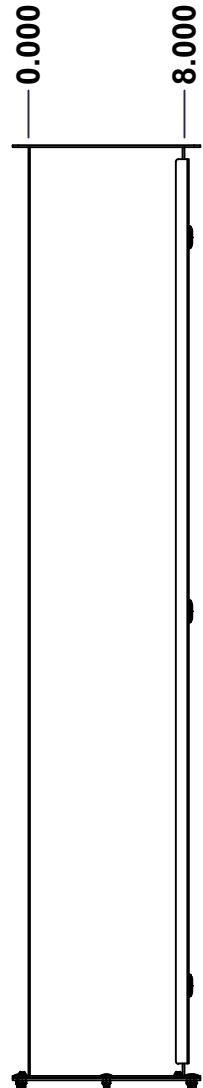

LEFT

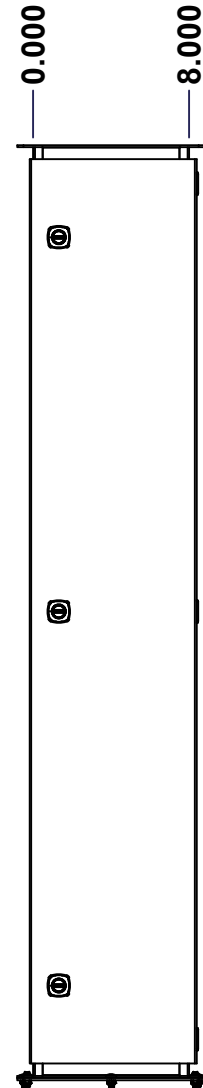

FRONT

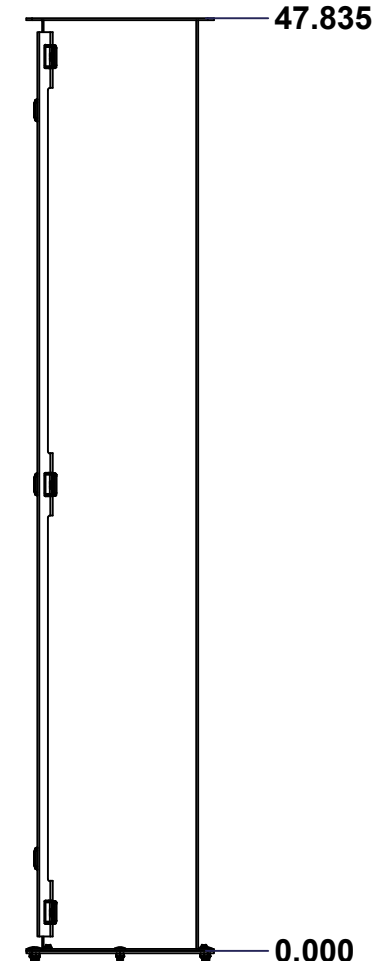

RIGHT

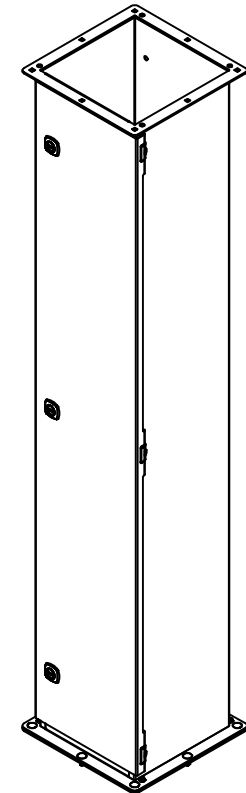

Isometric View

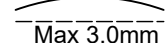
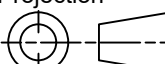

 Tél: (450) 979-4373 Fax: (450) 979-4626 www.exmweb.com		Flatness Aplatissement  Max 3.0mm Projection 
Customer Client	Date	
Drawn By Dessiné Par	BoxCad: HunterZ	Date 23-Mar-23
Material Matière	16 Ga Cold Rolled A1008 CS Type B (1.4mm)	
Color Couleur	Asa-61 Grey	Finish Fini Smooth
Description	Detail Rev.	
1412SS 48" x 8" x 8" Assembly		
Part Number Numéro Pièce	Rev. 0	1/8

SEE BILL OF MATERIAL ON LAST PAGE

1412SS8048

This drawing is confidential and must not be reproduced or used without the consent of EXM

Ce dessin est confidentiel et ne doit pas être reproduit ou utilisé sans le consentement de EXM

NOTE	
ITEM	DESCRIPTION
1	NEMA 4, 12 Enclosure (IP66)

APPROVED FOR PRODUCTION
APPROUVÉ POUR PRODUCTION
 SIGNATURE: _____
 NAME / NOM: _____
 DATE: _____
 Please visit: www.boxcadexm.com

No.	Revisions	Date	By/Par

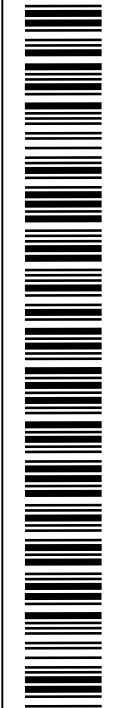
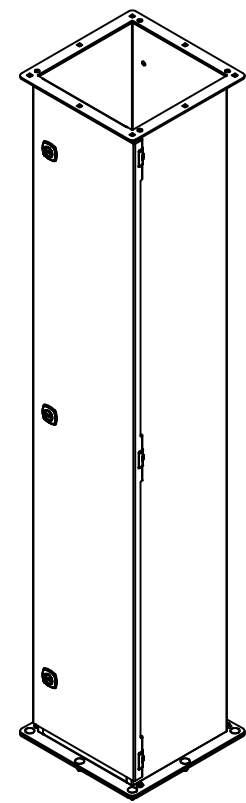

Isometric View

EXM
 Tél: (450) 979-4373
 Fax: (450) 979-4626
www.exmweb.com

Flatness
 Aplatissement
 Max 3.0mm
 Projection

Customer Client
 Drawn By Dessiné Par BoxCad: HunterZ
 Material Matière 16 Ga Cold Rolled A1008 CS Type B (1.4mm)
 Date 23-Mar-23

Color Couleur Asa-61 Grey
 Finish Fini Smooth
 Description 1412SS 48" x 8" x 8" Assembly
 Part Number Numéro Pièce **1412SS8048**
 Detail Rev. 2
 Rev. 0

8	STK-Q-00266	0	M6 x 16mm Stainless Steel 316 Carriage Bolt
1	STK-G-01630	1	1412 Pull Through Wireway Gasket
1	1412SS8048C	0	1412SS 48" x 8" Cover
1	1412SS8048B	0	1412SS 48" x 8" x 8" Body
3	STK-A-08126	0	M5 Stainless Steel 316 Nylon Insert Lock Nut with Incorporated Sealing Washer
8	STK-Q-07225	0	M6 Stainless Steel Nylon Insert Lock Nut
Qty	Part Number	Rev	Description
Parts List			

PACKING		
ITEM	QTY	DESCRIPTION
Cardboard sleeve	2	Top and Bottom
Plastic strap - Black	2	To Squeeze 2 cardboard sleeve together
Packaging label	3	White label with PN

This drawing is confidential and must not be reproduced or used without the consent of EXM

Ce dessin est confidentiel et ne doit pas être reproduit ou utilisé sans le consentement de EXM

APPROVED FOR PRODUCTION
APPROUVÉ POUR PRODUCTION
 SIGNATURE: _____
 NAME / NOM: _____
 DATE: _____
 Please visit: www.boxcadexm.com

No.	Revisions	Date	By/Par

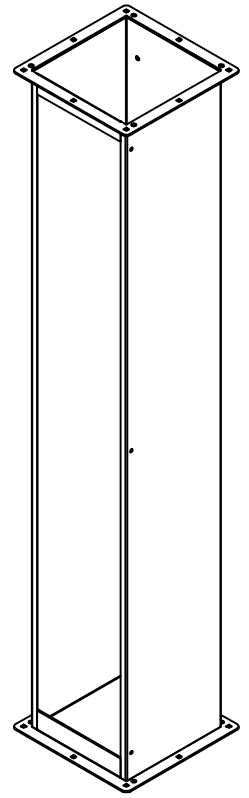
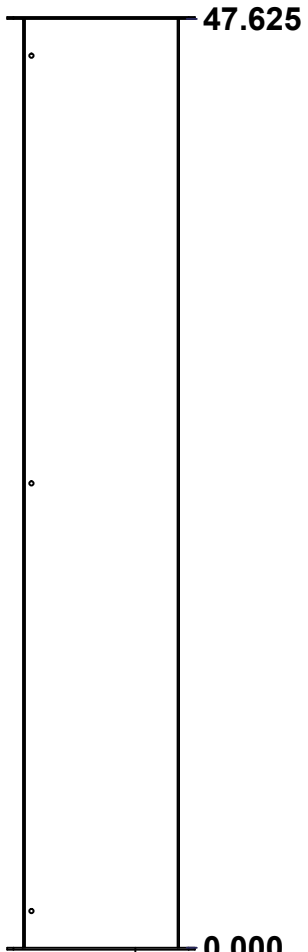
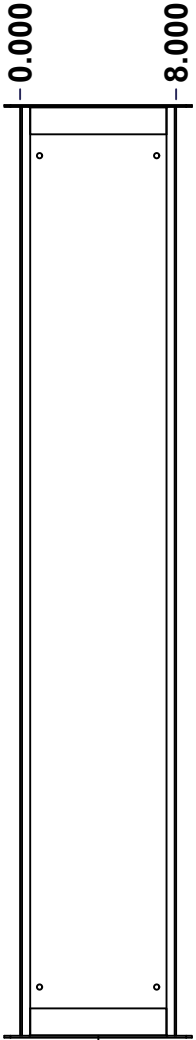
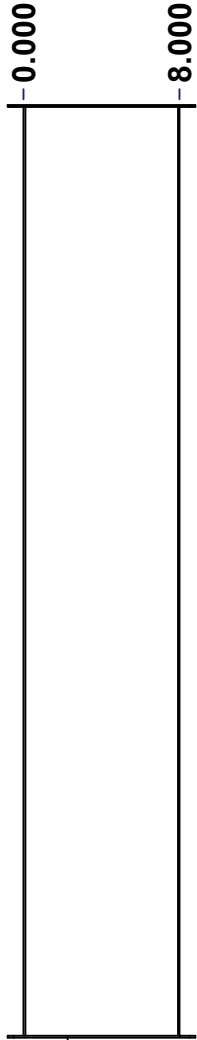
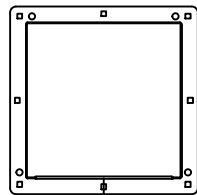
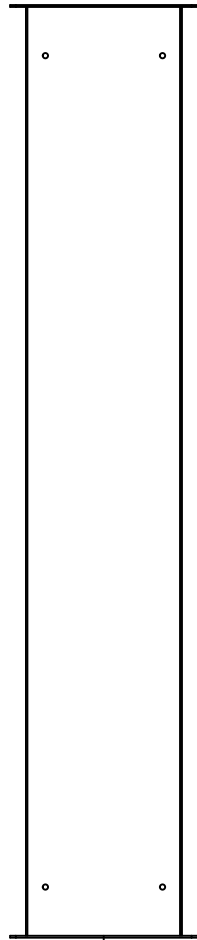
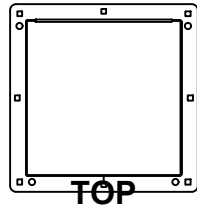

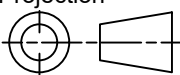
 Tél: (450) 979-4373 Fax: (450) 979-4626 www.exmweb.com		Flatness Aplatissement Max 3.0mm Projection 
Customer Client	Date	
Drawn By Dessiné Par	BoxCad: HunterZ	Date 23-Mar-23
Material Matière	16 Ga Cold Rolled A1008 CS Type B (1.4mm)	
Color Couleur	Asa-61 Grey	Finish Fini Smooth
Description 1412SS 48" x 8" x 8" Body		Detail Rev.
Part Number Numéro Pièce	Rev. 0	4 / 8

SEE BILL OF MATERIAL ON LAST PAGE

1412SS8048B

This drawing is confidential and must not be reproduced or used without the consent of EXM

Ce dessin est confidentiel et ne doit pas être reproduit ou utilisé sans le consentement de EXM

APPROVED FOR PRODUCTION
APPROUVÉ POUR PRODUCTION
 SIGNATURE: _____
 NAME / NOM: _____
 DATE: _____
 Please visit: www.boxcadexm.com

No.	Revisions	Date	By/Par

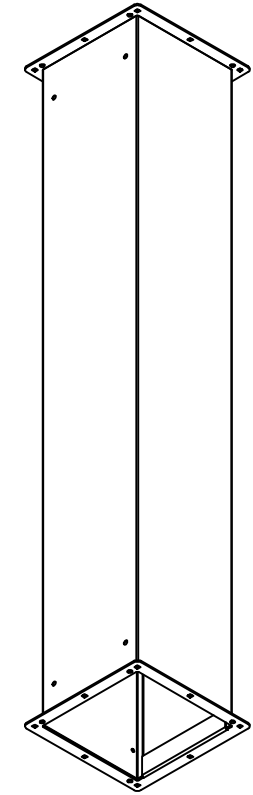

Isometric View

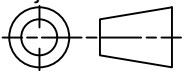

 Tél: (450) 979-4373 Fax: (450) 979-4626 www.exmweb.com		Flatness Aplatissement Max 3.0mm
Customer Client		Projection 
Drawn By / Dessiné Par: BoxCad: HunterZ		Date: 23-Mar-23
Material / Matière: 16 Ga Cold Rolled A1008 CS Type B (1.4mm)		
Color / Couleur: Asa-61 Grey	Finish / Fini: Smooth	
Description: 1412SS 48" x 8" x 8" Body		Detail Rev.
Part Number / Numéro Pièce: 1412SS8048B		Rev. 5 0

Qty	Part Number	Rev	Description
1	STK-P-02400S	0	Powder Paint (Asa-61 Grey / Smooth)
2	1412SS8048BC-P	0	1412SS8" x 8" Connector Part
1	1412SS8048B-P	0	1412SS 48" x 8" x 8" Body Part
Parts List			

This drawing is confidential and must not be reproduced or used without the consent of EXM

Ce dessin est confidentiel et ne doit pas être reproduit ou utilisé sans le consentement de EXM

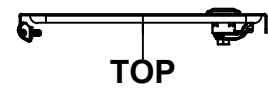

TOP

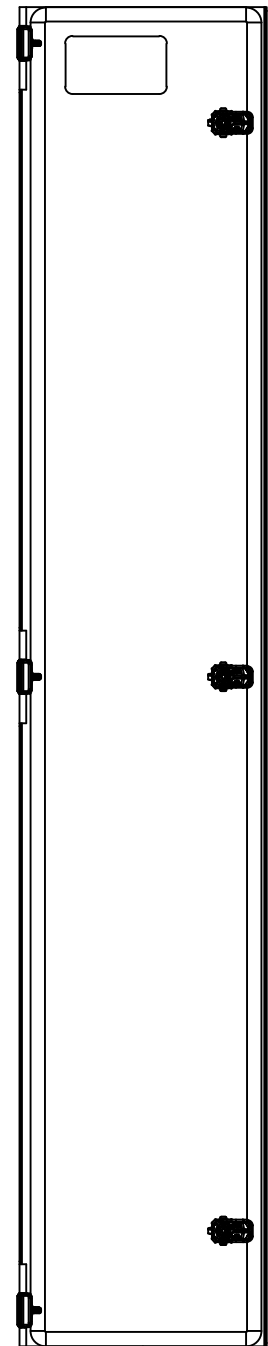

BACK



BOTTOM

0.000
0.660

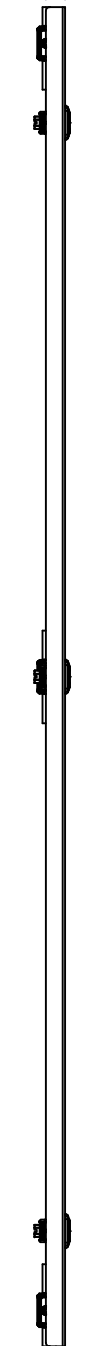

LEFT

0.000
8.565

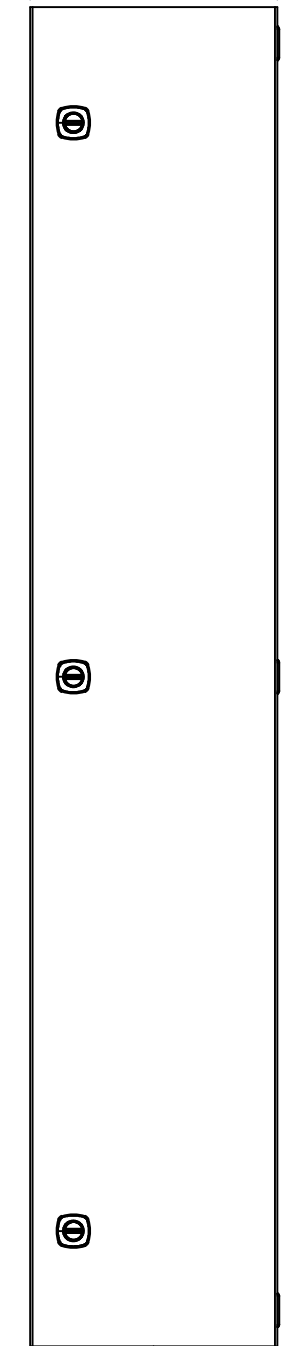

FRONT

46.375

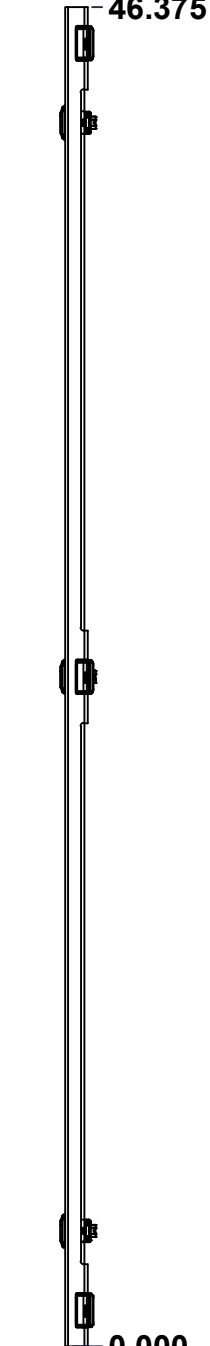

RIGHT

APPROVED FOR PRODUCTION
APPROUVÉ POUR PRODUCTION

SIGNATURE: _____

NAME / NOM: _____

DATE: _____

Please visit: www.boxcadexm.com

No.	Revisions	Date	By/Par

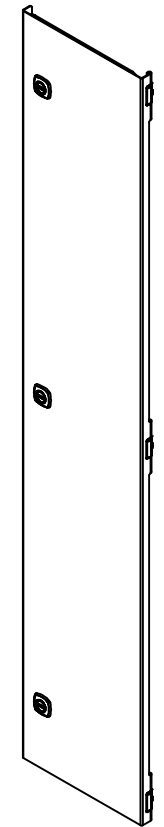

Isometric View



Tél: (450) 979-4373
Fax: (450) 979-4626
www.exmweb.com

Flatness
Aplatissement

Max 3.0mm

Projection

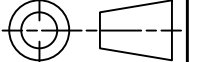

Customer Client	Date
Drawn By Dessiné Par	Date
Material Matière	23-Mar-23
Color Couleur	16 Ga Cold Rolled A1008 CS Type B (1.4mm)
Asa-61 Grey	Finish Fini
Smooth	Description
Detail Rev.	1412SS 48" x 8" Cover
Part Number Numéro Pièce	Rev.
1412SS8048C	6
	8

SEE BILL OF MATERIAL ON LAST PAGE

This drawing is confidential and must not be reproduced or used without the consent of EXM

Ce dessin est confidentiel et ne doit pas être reproduit ou utilisé sans le consentement de EXM

STANDARD FEATURES ARE NOT LISTED IN THIS HOLE TABLE

HOLE TABLE - FRONT VIEW (CUSTOM FEATURE ONLY)

CUT-OUT	XDIM	YDIM	DESCRIPTION
1	3.000	44.375	LABEL_EXM
2	7.065	23.188	LOCK 880 SCQ4CH-SL @ 180.0°
3	7.065	4.000	LOCK 880 SCQ4CH-SL @ 180.0°
4	7.065	42.375	LOCK 880 SCQ4CH-SL @ 180.0°

APPROVED FOR PRODUCTION
APPROUVÉ POUR PRODUCTION
 SIGNATURE: _____
 NAME / NOM: _____
 DATE: _____
 Please visit: www.boxcadexm.com

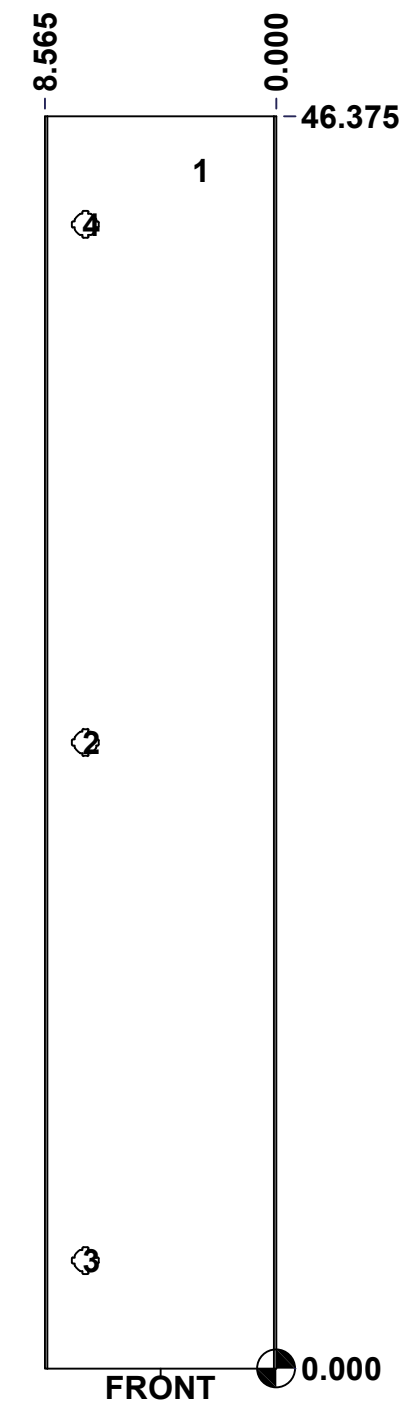

	Description	Status	
	1412SS 48" x 8" x 8" Cover	(NULL)	
	Part Number Numéro Pièce	Rev.	
	1412SS8048C	0	7 8

This drawing is confidential and must not be reproduced or used without the consent of EXM

Ce dessin est confidentiel et ne doit pas être reproduit ou utilisé sans le consentement de EXM

APPROVED FOR PRODUCTION
APPROUVÉ POUR PRODUCTION
 SIGNATURE: _____
 NAME / NOM: _____
 DATE: _____
 Please visit: www.boxcadexm.com

No.	Revisions	Date	By/Par

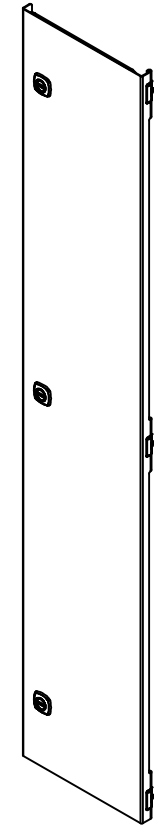

Isometric View



EXM
 Tél: (450) 979-4373
 Fax: (450) 979-4626
www.exmweb.com

Flatness
 Aplatissement
 Max 3.0mm

Projection

Customer Client _____ Date _____
 Drawn By Dessiné Par BoxCad: HunterZ Date 23-Mar-23
 Material Matière 16 Ga Cold Rolled A1008 CS Type B (1.4mm)

Color Couleur Asa-61 Grey Finish Fini Smooth

Description 1412SS 48" x 8" Cover Detail Rev. _____

Part Number Numéro Pièce **1412SS8048C** Rev. **0** 8

Qty	Part Number	Rev	Description
1	STK-S-00100	0	3.5" x 2" Silver Milar Flexcon Sticker
1	1412SS8048G	0	1412SS 48" x 8" Cover Gasket Part
1	STK-P-02400S	0	Powder Paint (Asa-61 Grey / Smooth)
1	1412SS8048C-P	0	1412SS 48" x 8" x 8" Cover Part
3	STK-A-33033	4	5412 ESMCH Hinge
3	880 SCQ4CH-SL	0	5412 CH 1/4 Turn Lock
Parts List			