

This drawing is confidential and must not be reproduced or used without the consent of EXM

Ce dessin est confidentiel et ne doit pas être reproduit ou utilisé sans le consentement de EXM

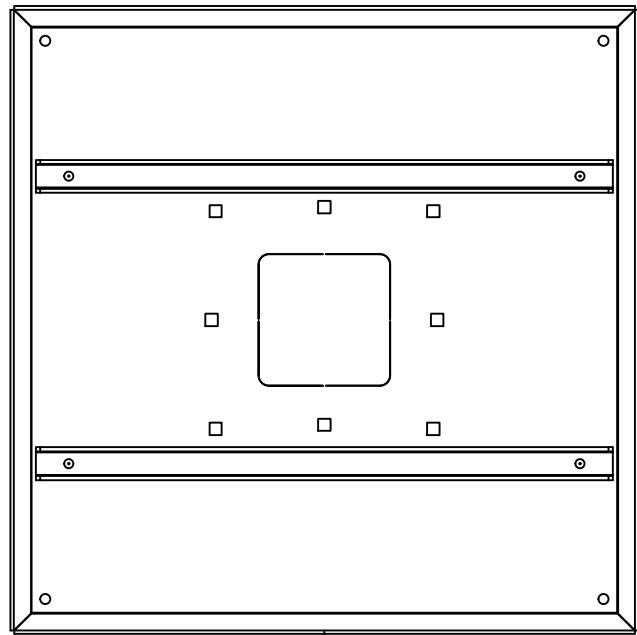

TOP



BACK

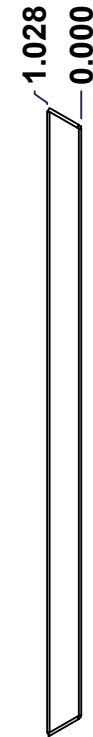

LEFT

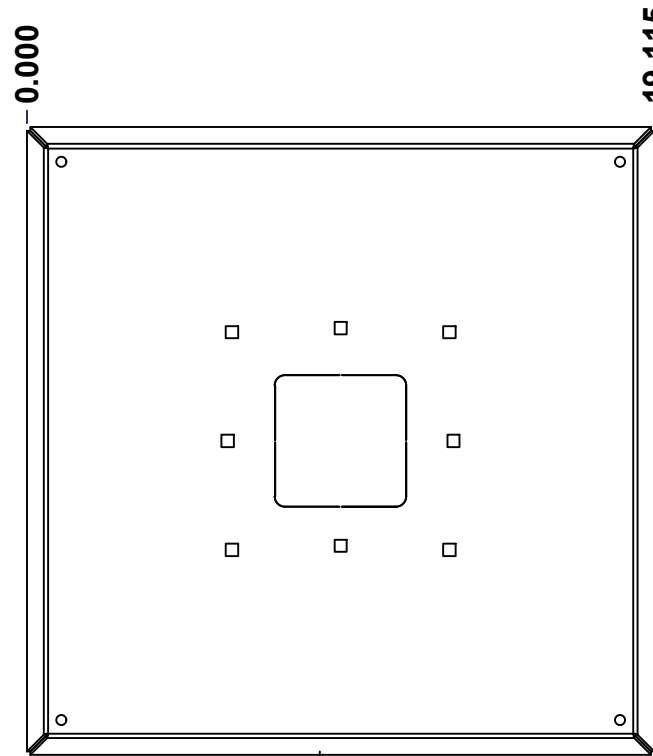

FRONT

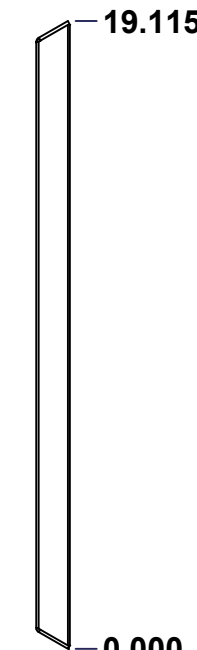

RIGHT



BOTTOM

No.	Revisions	Date	By/Par

Isometric View

Tél: (450) 979-4373 Fax: (450) 979-4626 www.exmweb.com		Flatness Aplatissement	
		Max 3.0mm	
Customer Client		Date	
Drawn By Dessiné Par		Date	
Material Matière		11 Ga Stainless Steel 304 (3.0mm)	
Color Couleur		Unpainted	Finish Fini
Description		Detail Rev.	
1500BASS 18" x 18" x 1" Assembly			
Part Number Numéro Pièce		Rev.	1
1500BASS181801		0	2

SEE BILL OF MATERIAL ON LAST PAGE

This drawing is confidential and must not be reproduced or used without the consent of EXM

Ce dessin est confidentiel et ne doit pas être reproduit ou utilisé sans le consentement de EXM

No.	Revisions	Date	By/Par

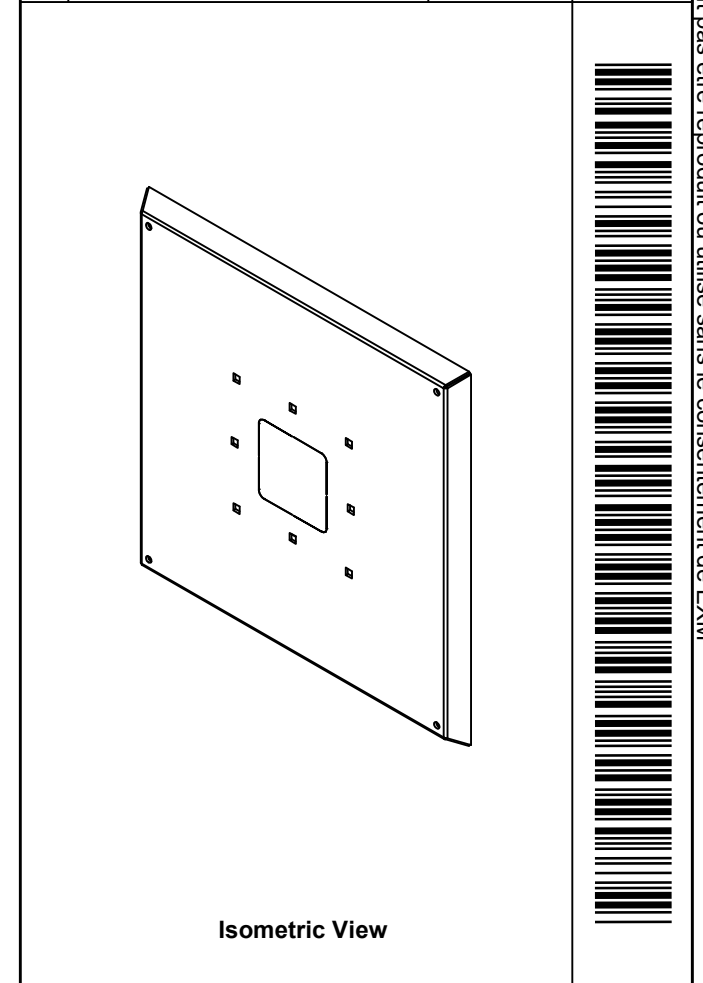

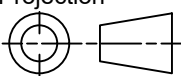
 Tél: (450) 979-4373 Fax: (450) 979-4626 www.exmweb.com		Flatness Aplatissement Max 3.0mm
Customer Client		Projection 
Drawn By / Dessiné Par: BoxCad: BoxCad		Date: 05-Jun-23
Material / Matière: 11 Ga Stainless Steel 304 (3.0mm)		
Color / Couleur: Unpainted	Finish / Fini: Brushed	
Description: 1500BASS 18" x 18" x 1" Assembly		Detail Rev.
Part Number / Numéro Pièce: 1500BASS181801		Rev. 0

Qty	Part Name	Rev	Description
2	1500BASS181801-S	0	1500BASS18" x 18" x 1" Stiffener Part
1	1500BASS181801-P	0	1500BASS18" x 18" x 1" Base Part
Parts List			