

This drawing is confidential and must not be reproduced or used without the consent of EXM

Ce dessin est confidentiel et ne doit pas être reproduit ou utilisé sans le consentement de EXM

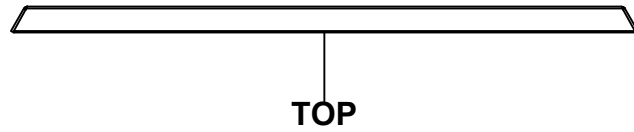

TOP

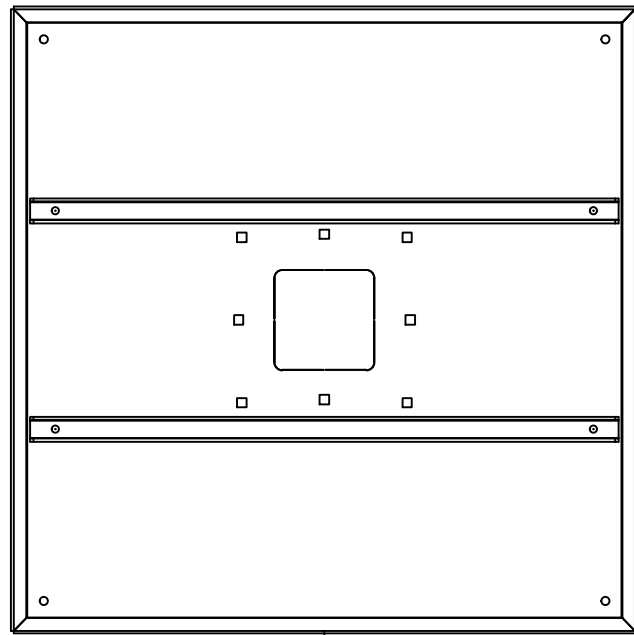

BACK

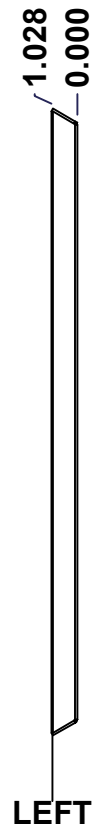

LEFT

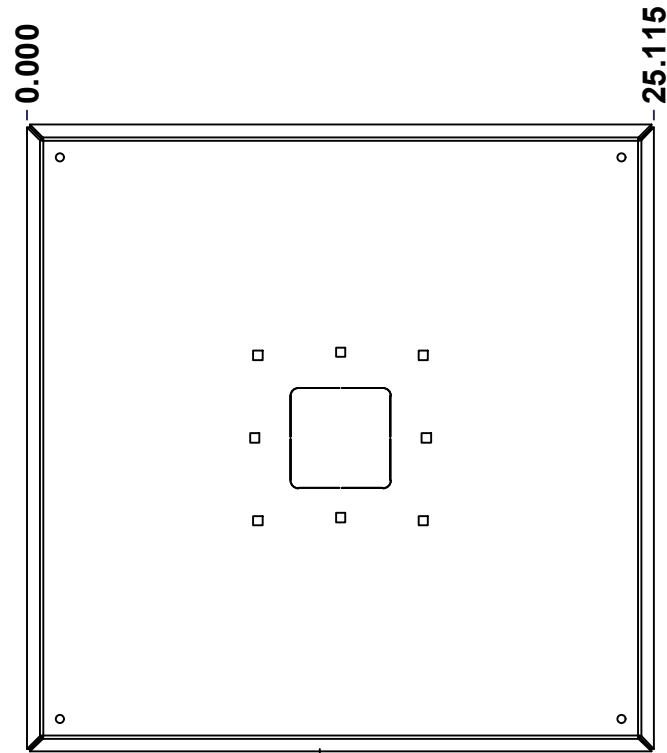

FRONT

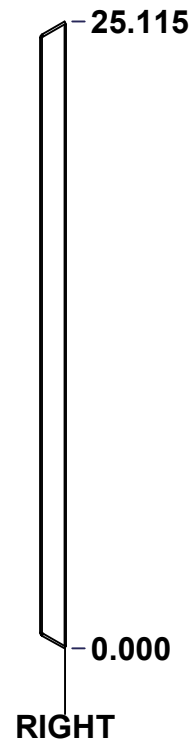

RIGHT

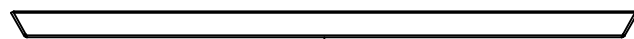

BOTTOM

No.	Revisions	Date	By/Par

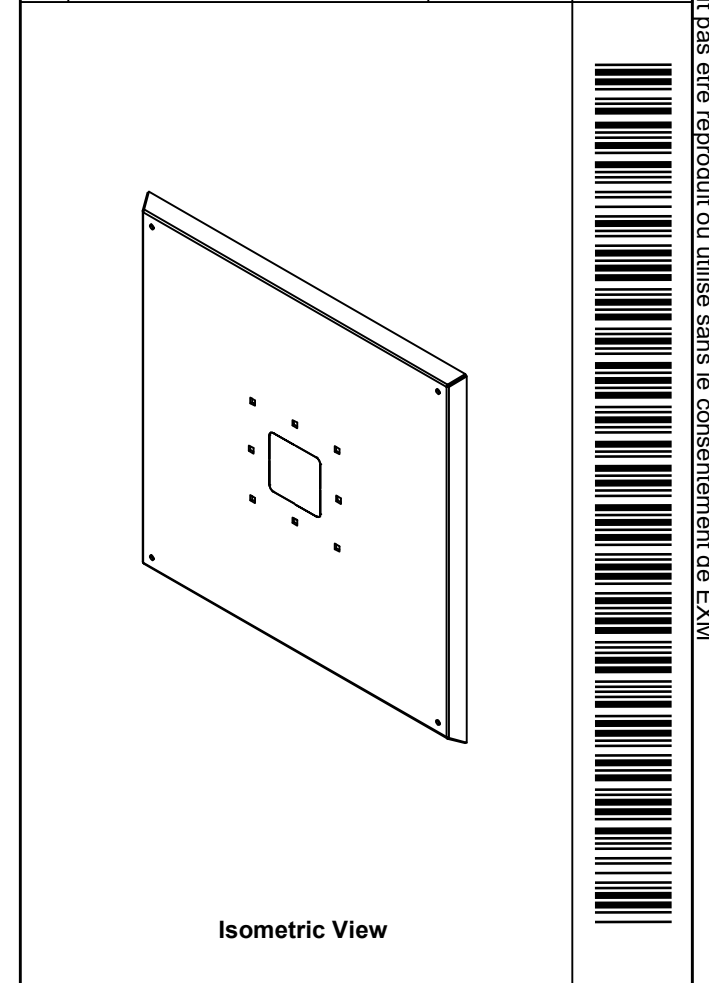

Isometric View

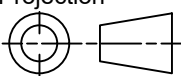

 Tél: (450) 979-4373 Fax: (450) 979-4626 <a href="http://www.exmweb.com">www.exmweb.com</a>		Flatness Aplatissement Max 3.0mm Projection 
Customer Client	Date	
Drawn By Dessiné Par	BoxCad: BoxCad	Date 09-Sep-25
Material Matière	11 Ga Stainless Steel 304 (3.0mm)	
Color Couleur	Unpainted	Finish Fini Brushed
Description	Detail Rev.	
1500BASS 24" x 24" x 1" Assembly		
Part Number Numéro Pièce	Rev.	1
1500BASS242401	0	2

SEE BILL OF MATERIAL ON LAST PAGE

This drawing is confidential and must not be reproduced or used without the consent of EXM

Ce dessin est confidentiel et ne doit pas être reproduit ou utilisé sans le consentement de EXM

No.	Revisions	Date	By/Par

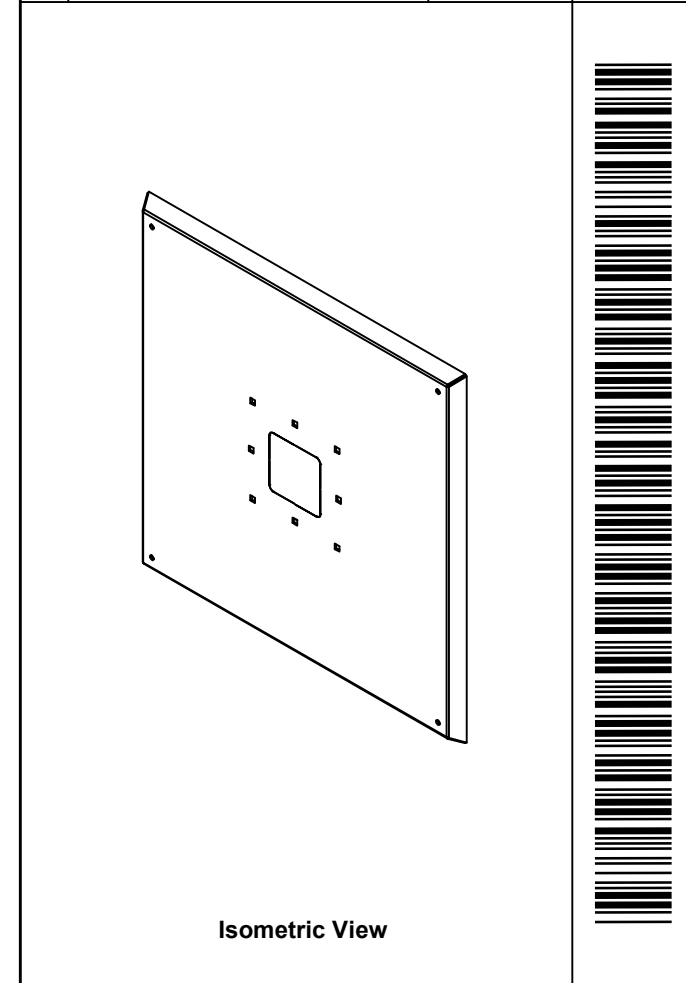

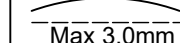
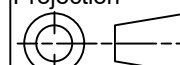
 Tél: (450) 979-4373 Fax: (450) 979-4626 <a href="http://www.exmweb.com">www.exmweb.com</a>		Flatness Aplatissement  Max 3.0mm
Customer Client		Projection 
Drawn By / Dessiné Par: BoxCad: BoxCad		Date: 09-Sep-25
Material / Matière: 11 Ga Stainless Steel 304 (3.0mm)		
Color / Couleur: Unpainted	Finish / Fini: Brushed	
Description: 1500BASS 24" x 24" x 1" Assembly		Detail Rev.
Part Number / Numéro Pièce: <b>1500BASS242401</b>		Rev. 0

Qty	Part Name	Rev	Description
2	1500BASS242401-S	0	1500BASS24" x 24" x 1" Stiffener Part
1	1500BASS242401-P	0	1500BASS24" x 24" x 1" Base Part
Parts List			