

This drawing is confidential and must not be reproduced or used without the consent of EXM

Ce dessin est confidentiel et ne doit pas être reproduit ou utilisé sans le consentement de EXM

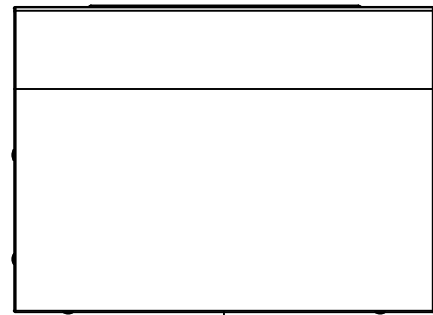

TOP

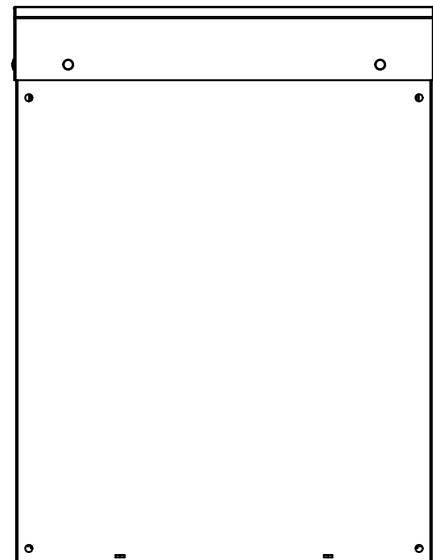

BACK

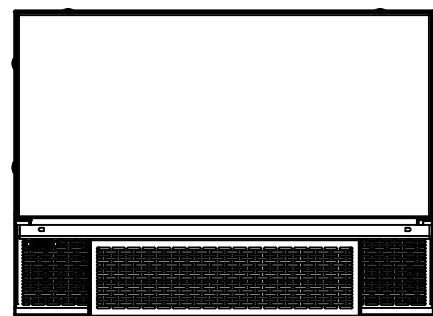

BOTTOM

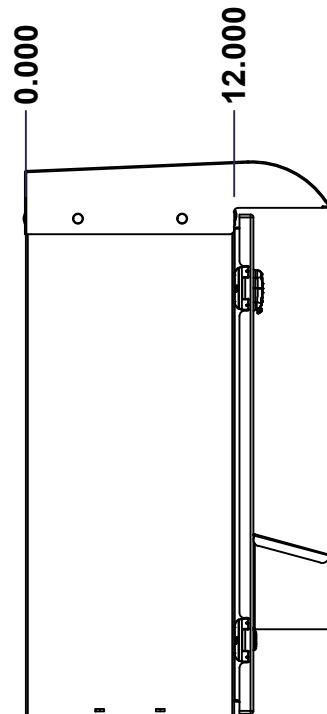

LEFT

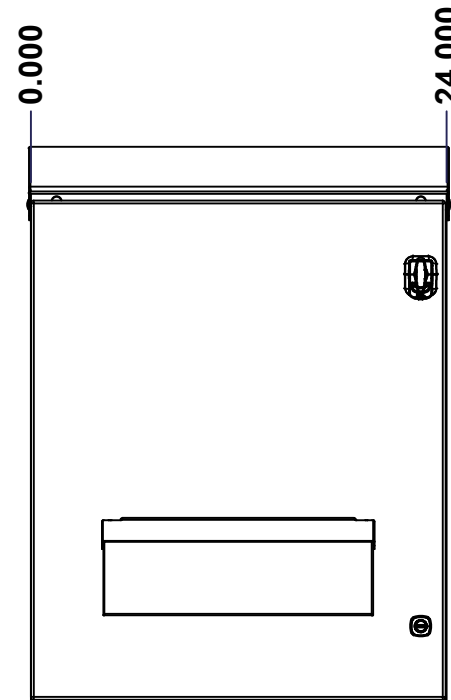

FRONT

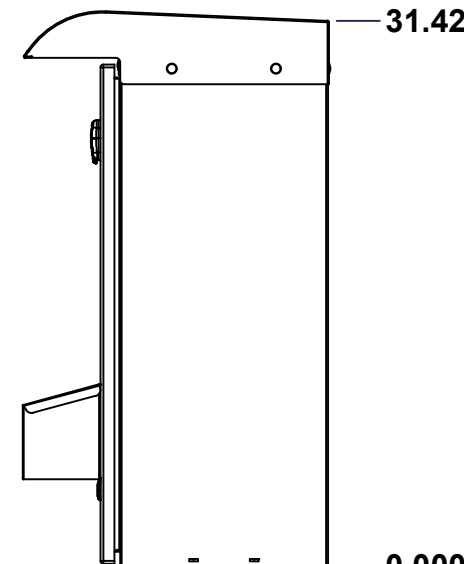

RIGHT

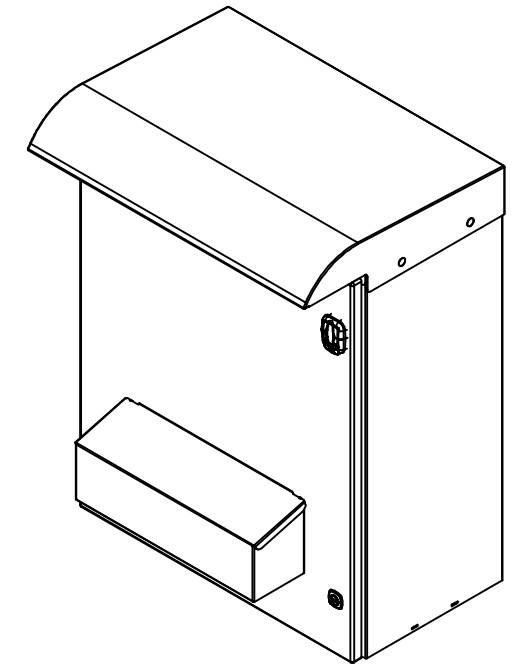

Isometric View

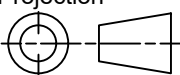

No.	Revisions	Date	By/Par

 Tél: (450) 979-4373 Fax: (450) 979-4626 <a href="http://www.exmweb.com">www.exmweb.com</a>		Flatness Aplatissement Max 3.0mm Projection 
Customer Client	Date	
Drawn By Dessiné Par	BoxCad: BoxCad	Date 13-Jun-18
Material Matière	14 Ga Cold Rolled A1008 CS Type B (1.7mm)	
Color Couleur	White RAL9003 (Over Primer STK-P-04752)	Finish Fini Rough Textured
Description 5300EWB 29" x 24" x 12" Assembly		Detail Rev.
Part Number Numéro Pièce	Rev. 0	1 9

SEE BILL OF MATERIAL ON LAST PAGE

**5300EWB292412**

This drawing is confidential and must not be reproduced or used without the consent of EXM

Ce dessin est confidentiel et ne doit pas être reproduit ou utilisé sans le consentement de EXM

NOTE	
ITEM	DESCRIPTION
1	NEMA 3, 3R Enclosure (IP64)
2	C/W Powdura® Epoxy Powder Coating Primer
3	C/W Standard ground studs on box and cover
4	W/O Standard door stiffener
5	W/O Inner panel
6	C/W Standard inner panel mounting studs
7	C/W 01141.9-00 Included (Installed)

No.	Revisions	Date	By/Par

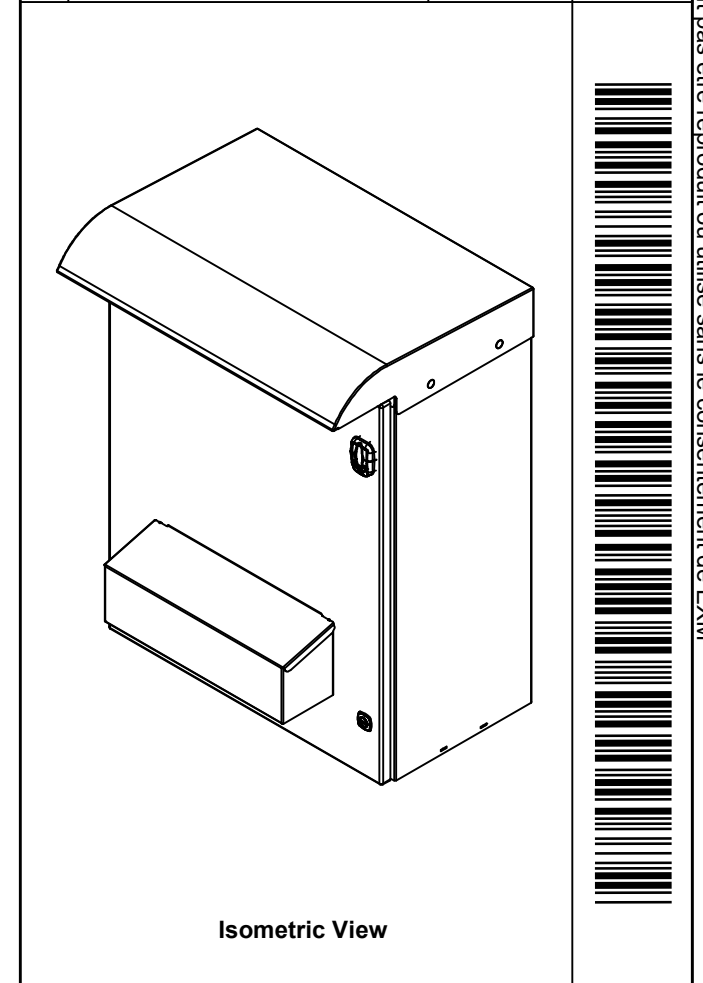

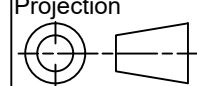
 Tél: (450) 979-4373 Fax: (450) 979-4626 <a href="http://www.exmweb.com">www.exmweb.com</a>	Flatness Aplatissement Max 3.0mm
	Projection 
Customer Client	Date
Drawn By / Dessiné Par: BoxCad: BoxCad	Date: 13-Jun-18
Material / Matière: 14 Ga Cold Rolled A1008 CS Type B (1.7mm)	
Color / Couleur: White RAL9003 (Over Primer STK-P-04752)	Finish / Fini: Rough Textured

PACKING		
ITEM	QTY	DESCRIPTION
Cardboard sleeve	2	Top and Bottom
Cardboard strip	2	Between back of enclosure and inner panel
Plastic bag	1	To protect cover surface and inside gasket
Plastic strap - Black	2	To Squeeze the 2 cardboard sleeve together
Packaging label	1	White label with product number

Qty	Part Number	Rev	Description
2	STK-Q-04050-10	8	M6 x 10mm Hexagon Socket Head Machine Screw with Nyseal
1	5300EWB292412C	0	5300EWB 29" x 24" x 12" Cover
1	5300EWB292412B	0	5300EWB 29" x 24" x 12" Body
Parts List			

Description: 5300EWB 29" x 24" x 12" Assembly		Detail Rev.	
Part Number / Numéro Pièce: <b>5300EWB292412</b>		Rev.:	2
		<b>0</b>	9

This drawing is confidential and must not be reproduced or used without the consent of EXM

Ce dessin est confidentiel et ne doit pas être reproduit ou utilisé sans le consentement de EXM

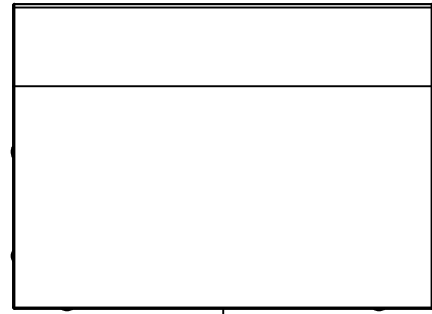

TOP

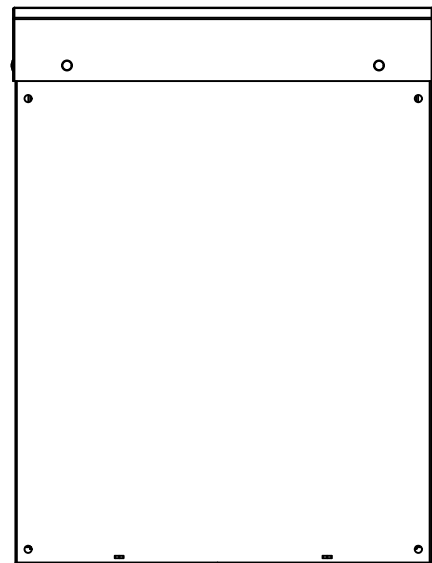

BACK



BOTTOM

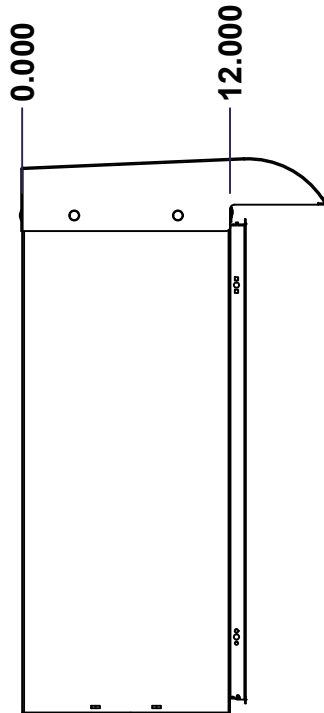

LEFT

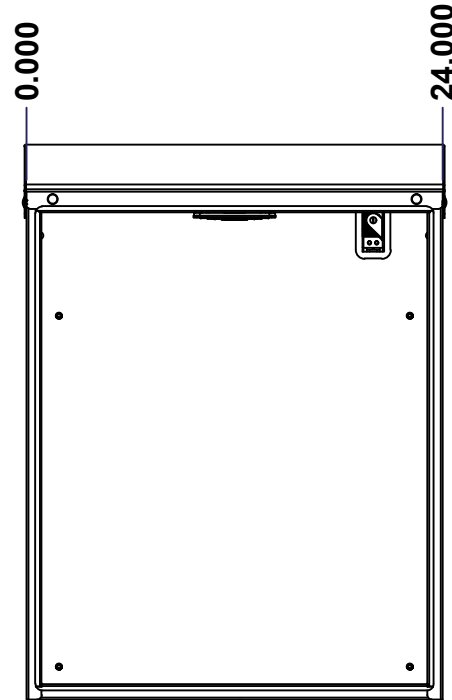

FRONT

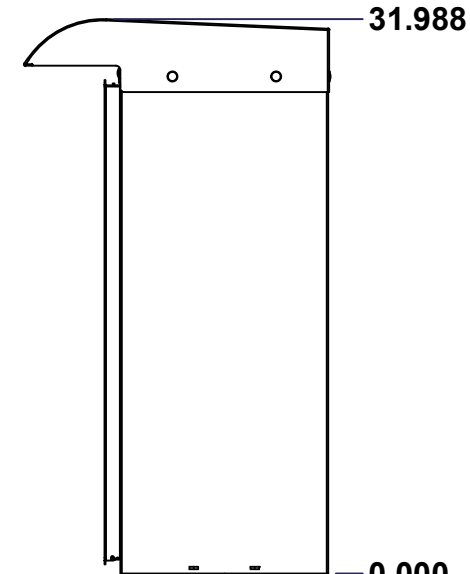

RIGHT

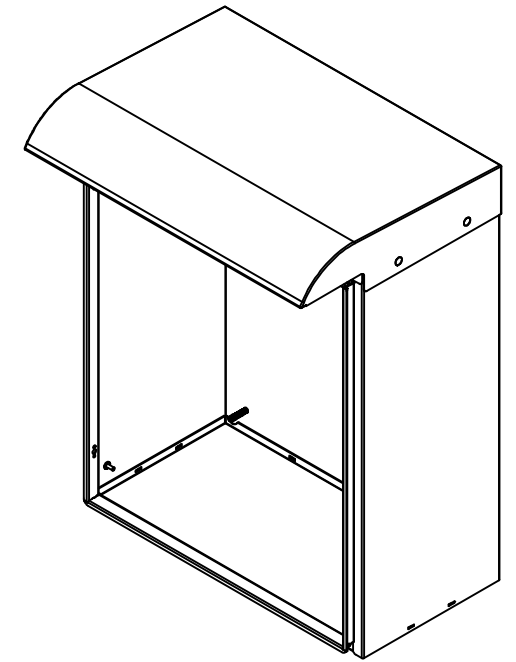

Isometric View

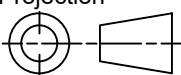

No.	Revisions	Date	By/Par

 Tél: (450) 979-4373 Fax: (450) 979-4626 <a href="http://www.exmweb.com">www.exmweb.com</a>		Flatness Aplatissement Max 3.0mm Projection 
Customer Client	Date	
Drawn By Dessiné Par	BoxCad: BoxCad	Date 13-Jun-18
Material Matière	14 Ga Cold Rolled A1008 CS Type B (1.7mm)	
Color Couleur	White RAL9003 (Over Primer STK-P-04752)	Finish Fini Rough Textured
Description	Detail Rev.	
5300EWB 29" x 24" x 12" Body		
Part Number Numéro Pièce	Rev.	3
<b>5300EWB292412B</b>	<b>0</b>	9

SEE BILL OF MATERIAL ON LAST PAGE

This drawing is confidential and must not be reproduced or used without the consent of EXM

Ce dessin est confidentiel et ne doit pas être reproduit ou utilisé sans le consentement de EXM

<b>STANDARD FEATURES ARE NOT LISTED IN THIS HOLE TABLE</b>			
<b>HOLE TABLE - LEFT VIEW (CUSTOM FEATURE ONLY)</b>			
CUT-OUT	XDIM	YDIM	DESCRIPTION
1	10.500	2.000	GND STUD M6 x 16mm (Inside)

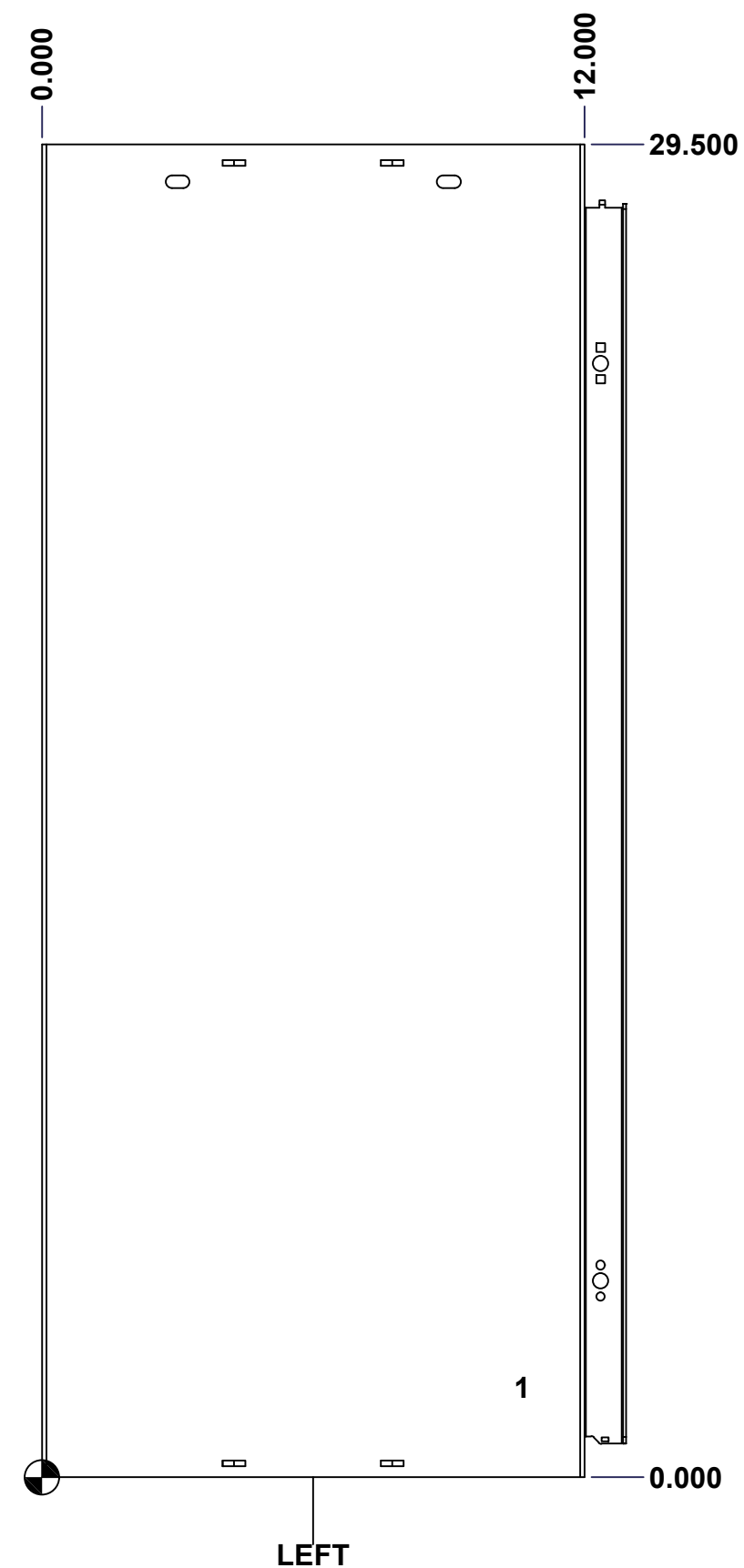

	Description	Status
	5300EWB 29" x 24" x 12" Body	(NULL)
Part Number Numéro Pièce <b>5300EWB292412B</b>	Rev.	4
	<b>0</b>	9

This drawing is confidential and must not be reproduced or used without the consent of EXM

Ce dessin est confidentiel et ne doit pas être reproduit ou utilisé sans le consentement de EXM

**STANDARD FEATURES ARE NOT LISTED IN THIS HOLE TABLE**

**HOLE TABLE - BACK VIEW (CUSTOM FEATURE ONLY)**

CUT-OUT	XDIM	YDIM	DESCRIPTION
1	1.875	1.875	IP STUD M8 x 35mm (Inside)
2	1.875	22.125	IP STUD M8 x 35mm (Inside)
3	22.125	22.125	IP STUD M8 x 35mm (Inside)
4	22.125	1.875	IP STUD M8 x 35mm (Inside)
-----			
5	23.250	0.750	RND Ø0.390
6	23.250	26.750	RND Ø0.390
7	0.750	26.750	RND Ø0.390
8	0.750	0.750	RND Ø0.390

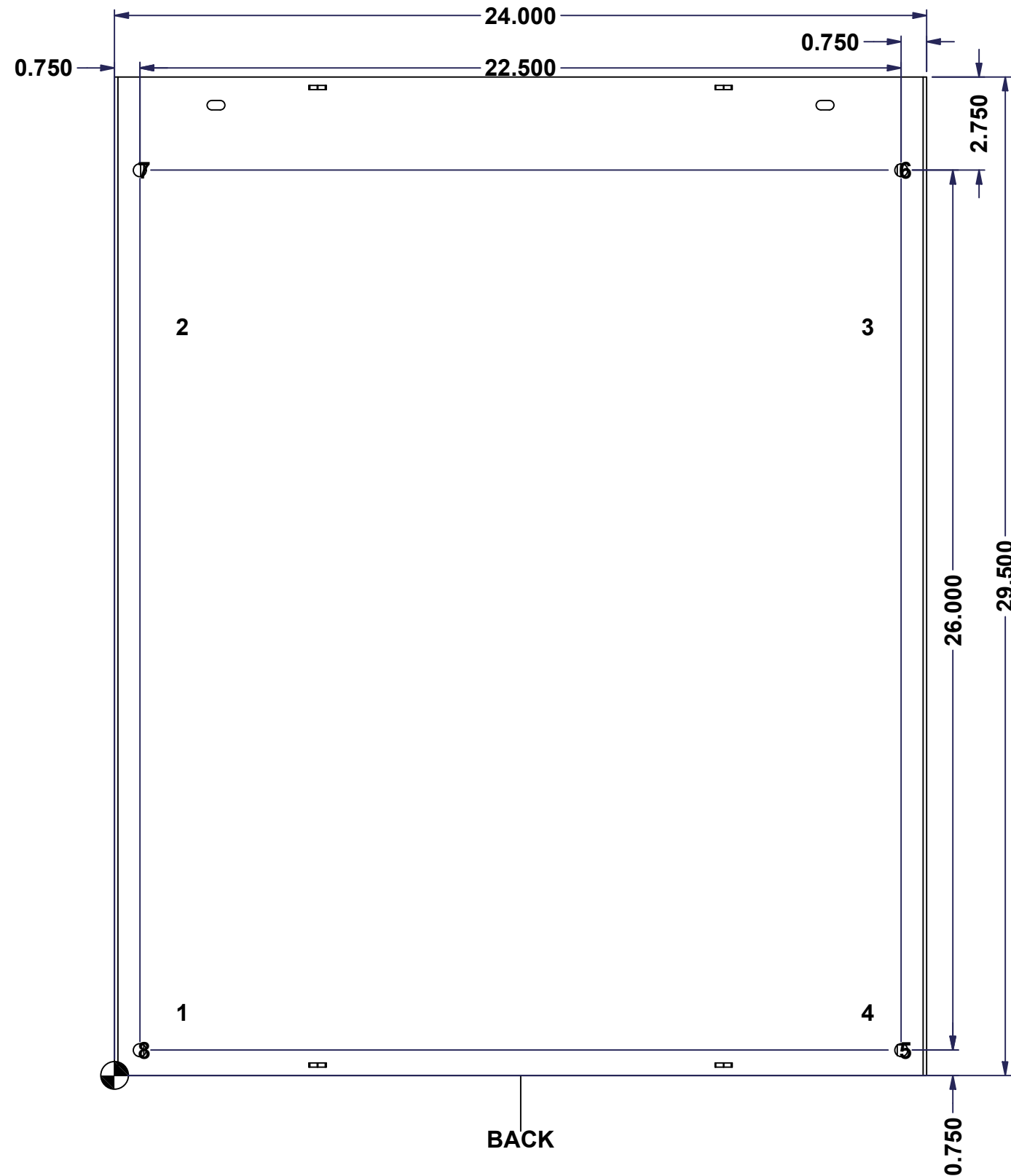

BACK

	Description	Status	
	5300EWB 29" x 24" x 12" Body	(NULL)	
	Part Number Numéro Pièce	Rev.	
	<b>5300EWB292412B</b>	<b>0</b>	5 9

This drawing is confidential and must not be reproduced or used without the consent of EXM

Ce dessin est confidentiel et ne doit pas être reproduit ou utilisé sans le consentement de EXM

No.	Revisions	Date	By/Par

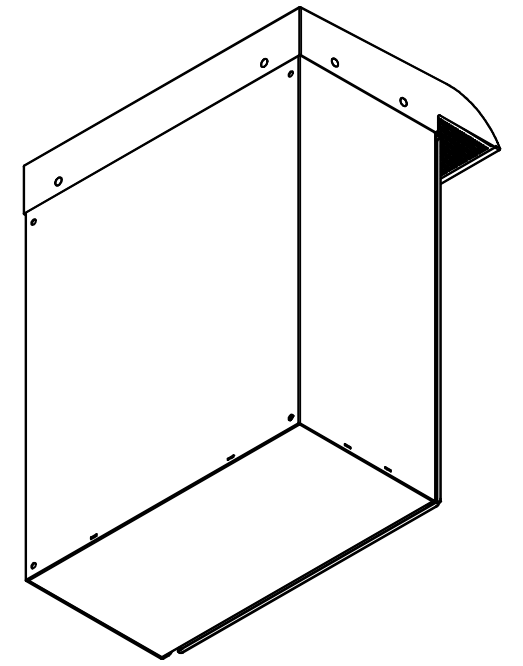

Isometric View



1	STK-Q-16080	0	Ground Stud M6 x 16mm Steel
1	STK-P-04752	0	Epoxy Primer Gray Powdura EAS6-C0000 (Bottom Layer)
1	STK-P-02401R	0	Powder Paint (White / Rough Textured)
1	01141.9-00	0	Small Thermostat (°F Normally Open)
1	5300EWB292412TH-P	0	5300EWB Thermostat Support Part
1	880FP150-117-115	8	Filter Fan - 150mm x 150mm (117CFM)
1	5300EWB292412GP-P	0	5300EWB 29" x 24" x 12" Fan Gland Plate Part
2	STK-Q-05020	5	M5 x 8mm Thread Rolling Screw
8	STK-Q-07220	1	M6 Nylon Insert Lock Nut
8	STK-Q-00260	1	M6 x 13mm Carriage Bolt
1	5300EWB292412T-P	0	5300EWB 24" x 12" Top Part
4	STK-Q-16005	0	Stud M8 x 35mm Steel
1	5300EWB292412BT-P	0	5300EWB 29" x 24" x 12" Bottom Part
1	5300EWB292412F-P	0	5300EWB 29" x 24" x 12" Front Part
1	5300EWB292412B-P	0	5300EWB 29" x 24" x 12" Body Part
Qty	Part Number	Rev	Description

Parts List

Tél: (450) 979-4373 Fax: (450) 979-4626 <a href="http://www.exmweb.com">www.exmweb.com</a>	Flatness Aplatissement
	Max 3.0mm
Projection	
Customer Client	Date
Drawn By Dessiné Par BoxCad: BoxCad	Date 13-Jun-18
Material Matière 14 Ga Cold Rolled A1008 CS Type B (1.7mm)	
Color Couleur White RAL9003 (Over Primer STK-P-04752)	Finish Fini Rough Textured
Description 5300EWB 29" x 24" x 12" Body	Detail Rev.
Part Number Numéro Pièce <b>5300EWB292412B</b>	Rev. 6 <b>0</b>

This drawing is confidential and must not be reproduced or used without the consent of EXM

Ce dessin est confidentiel et ne doit pas être reproduit ou utilisé sans le consentement de EXM

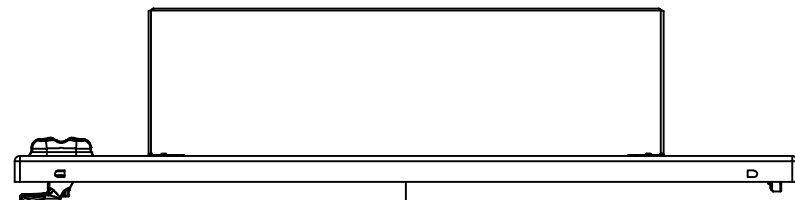

TOP

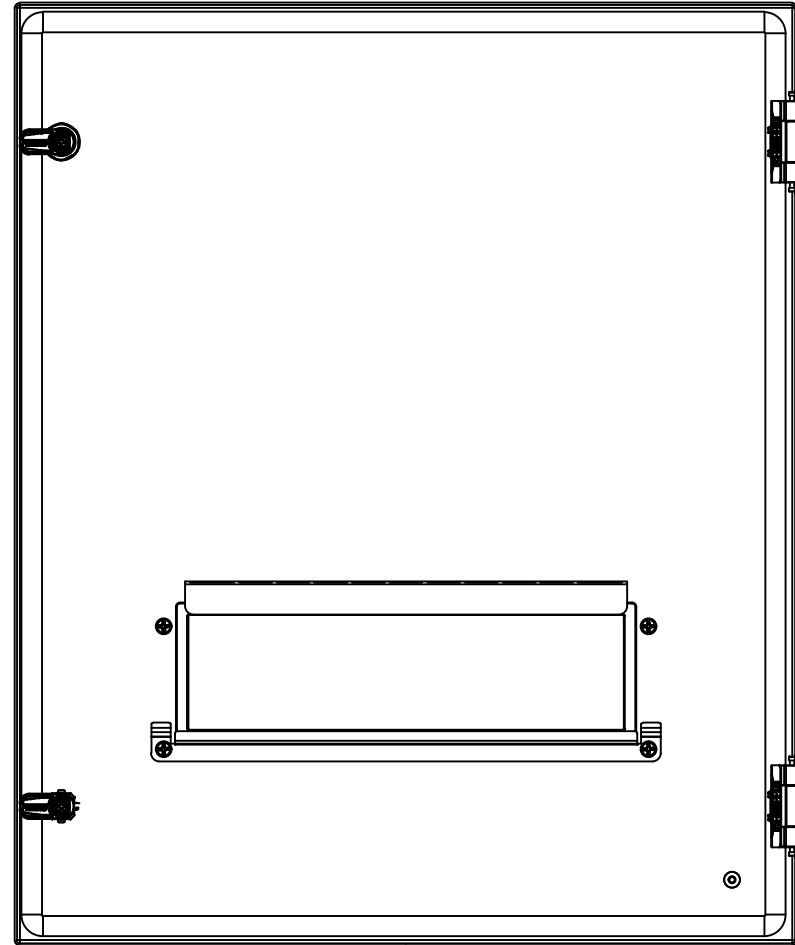

BACK

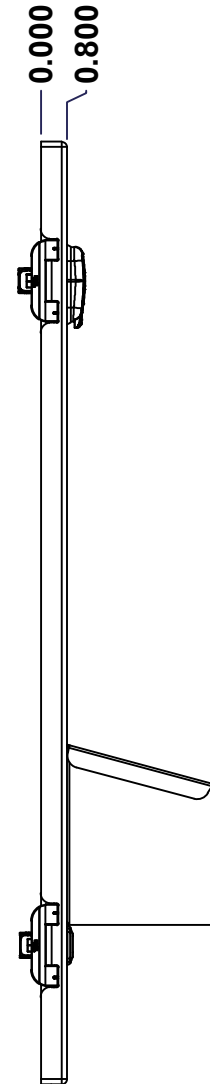

LEFT

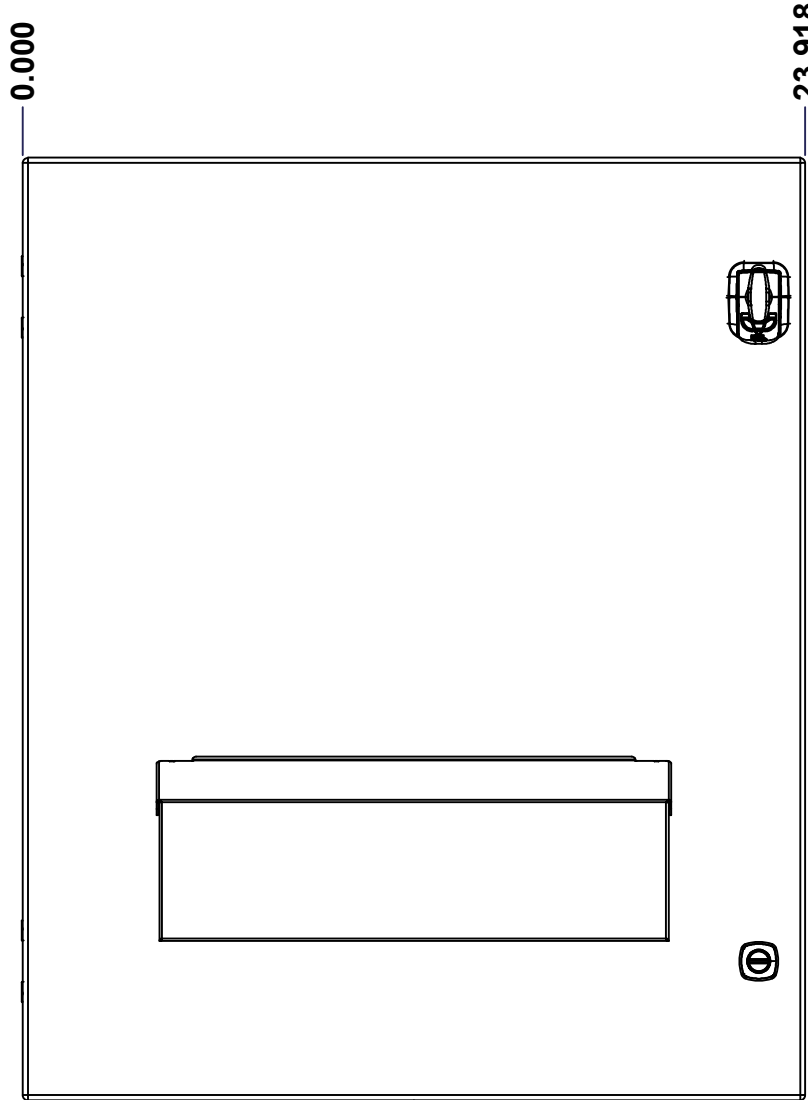

FRONT

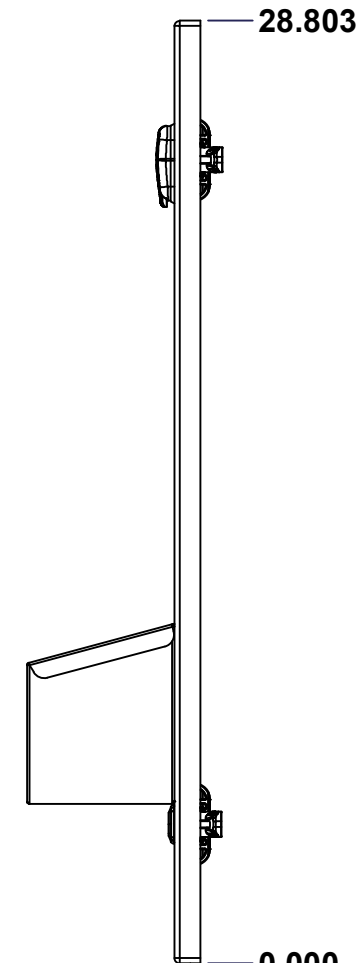

RIGHT

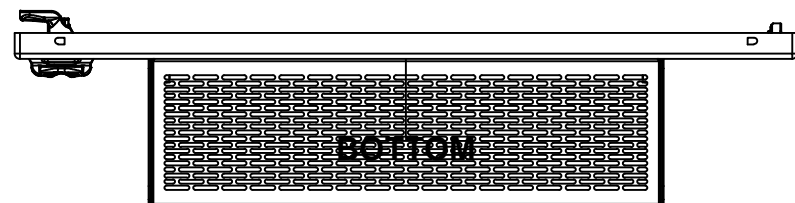

BOTTOM

No.	Revisions	Date	By/Par

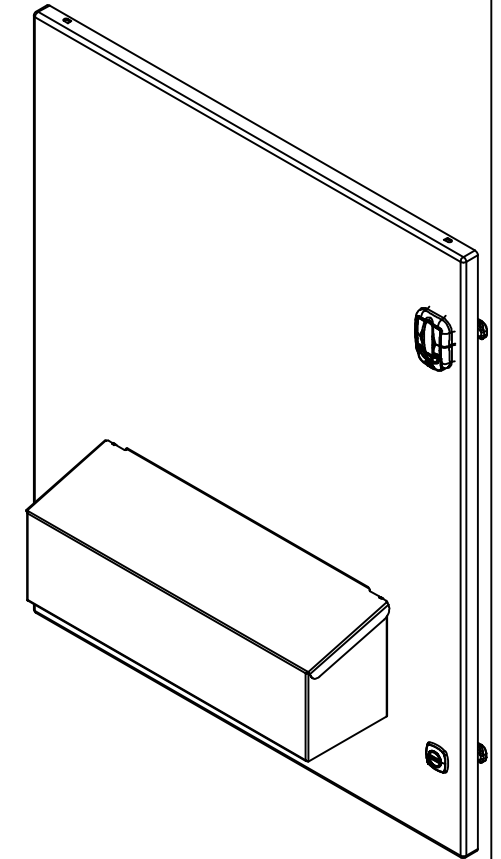

Isometric View



Tél: (450) 979-4373  
 Fax: (450) 979-4626  
[www.exmweb.com](http://www.exmweb.com)

Flatness  
Aplatissement

Max 3.0mm

Projection

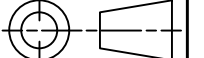

Customer Client	Date
Drawn By Dessiné Par BoxCad: BoxCad	Date 13-Jun-18
Material Matière 14 Ga Cold Rolled A1008 CS Type B (1.7mm)	
Color Couleur White RAL9003 (Over Primer STK-P-04752)	Finish Fini Rough Textured
Description 5300EWB 29" x 24" x 12" Cover	Detail Rev.
Part Number Numéro Pièce 5300EWB292412C	Rev. 7 0

SEE BILL OF MATERIAL ON LAST PAGE

This drawing is confidential and must not be reproduced or used without the consent of EXM

Ce dessin est confidentiel et ne doit pas être reproduit ou utilisé sans le consentement de EXM

**STANDARD FEATURES ARE NOT LISTED IN THIS HOLE TABLE**

**HOLE TABLE - FRONT VIEW (CUSTOM FEATURE ONLY)**

CUT-OUT	XDIM	YDIM	DESCRIPTION
1	2.000	2.000	GND STUD M6 x 16mm (Inside)
2	22.494	24.553	LOCK 880 SCQ4PL-SL @ 0.0°
3	22.494	4.250	LOCK 880 SCQ4-SL @ 0.0°

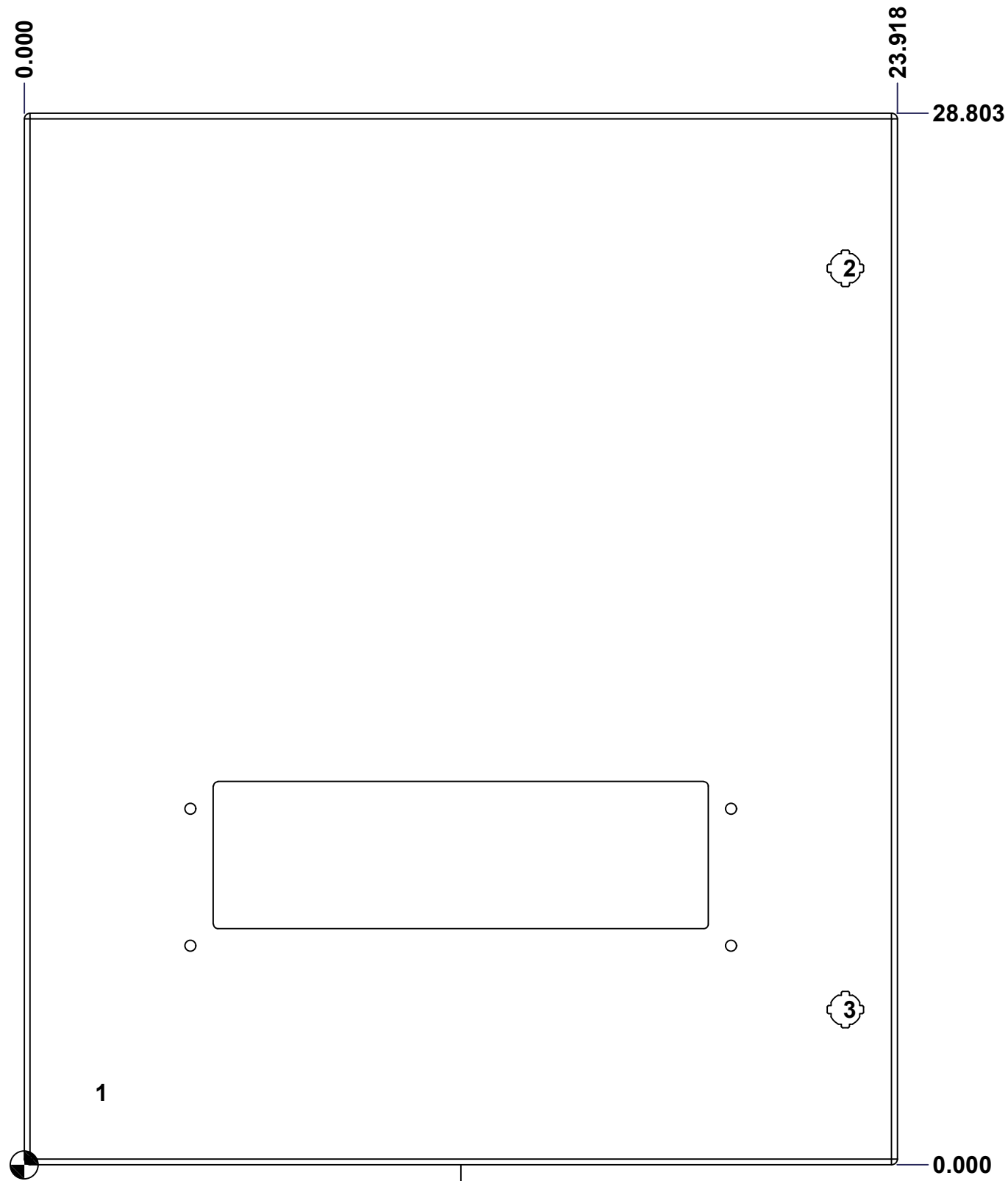

FRONT

	Description	Status
	5300EWB 29" x 24" Cover	(NULL)
	Part Number Numéro Pièce	Rev.
	<b>5300EWB292412C</b>	<b>0</b> / 8 / 9

This drawing is confidential and must not be reproduced or used without the consent of EXM

Ce dessin est confidentiel et ne doit pas être reproduit ou utilisé sans le consentement de EXM

No.	Revisions	Date	By/Par

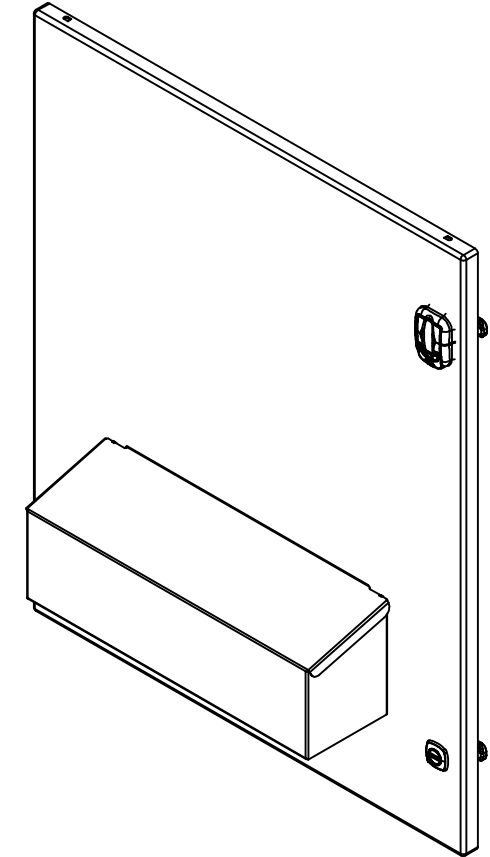

Isometric View



Tél: (450) 979-4373  
 Fax: (450) 979-4626  
[www.exmweb.com](http://www.exmweb.com)

Flatness  
Aplatissement  
Max 3.0mm  
Projection

1	STK-K-12500	18	5412 ES 1/4 Turn Lock
1	880 SCQ4PL-SL	3	5412 ES Padlockable 1/4 Turn Lock
1	STK-Q-16080	0	Ground Stud M6 x 16mm Steel
1	STK-P-04752	0	Epoxy Primer Gray Powdura EAS6-C0000 (Bottom Layer)
1	STK-P-02401R	0	Powder Paint (White / Rough Textured)
1	5300EWB292412LPH	0	Filter 14.062" x 4.250"
1	5300EWB292412FPH117	0	5300EWB 29" x 24" x 12" Rain Hood
1	5300EWB292412G	0	5300EWB 29" x 24" Cover Gasket Part
2	STK-K-09800	10	5412 ES Hinge with 2 Captive Hinge Pins
1	5300EWB292412C-P	0	5300EWB 29" x 24" Cover Part

Customer Client  
 Drawn By / Dessiné Par: BoxCad: BoxCad  
 Date: 13-Jun-18  
 Material / Matière: 14 Ga Cold Rolled A1008 CS Type B (1.7mm)

Color / Couleur: White RAL9003 (Over Primer STK-P-04752)  
 Finish / Fini: Rough Textured

Description: 5300EWB 29" x 24" x 12" Cover  
 Detail Rev.

Part Number / Numéro Pièce: **5300EWB292412C**  
 Rev. 0

Qty	Part Name	Rev	Description
Parts List			

9