

This drawing is confidential and must not be reproduced or used without the consent of EXM

Ce dessin est confidentiel et ne doit pas être reproduit ou utilisé sans le consentement de EXM

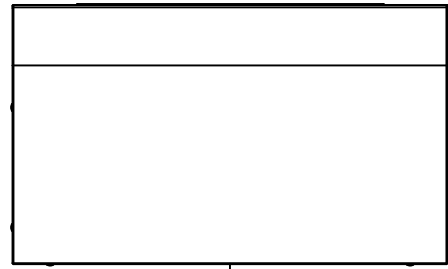

TOP

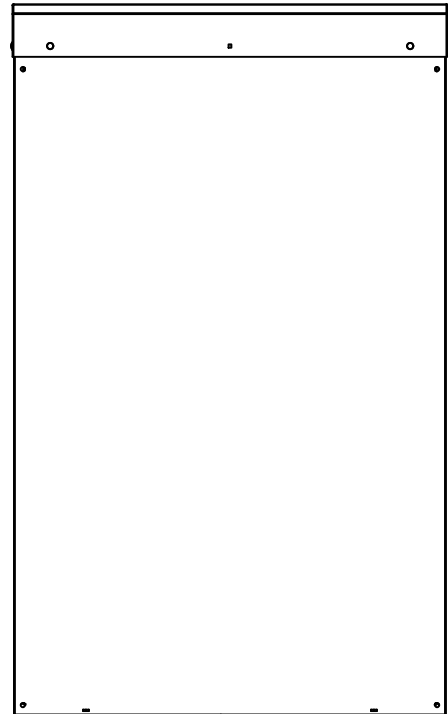

BACK



BOTTOM

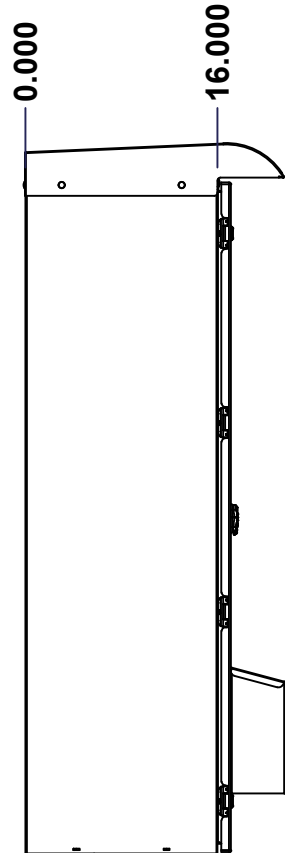

LEFT

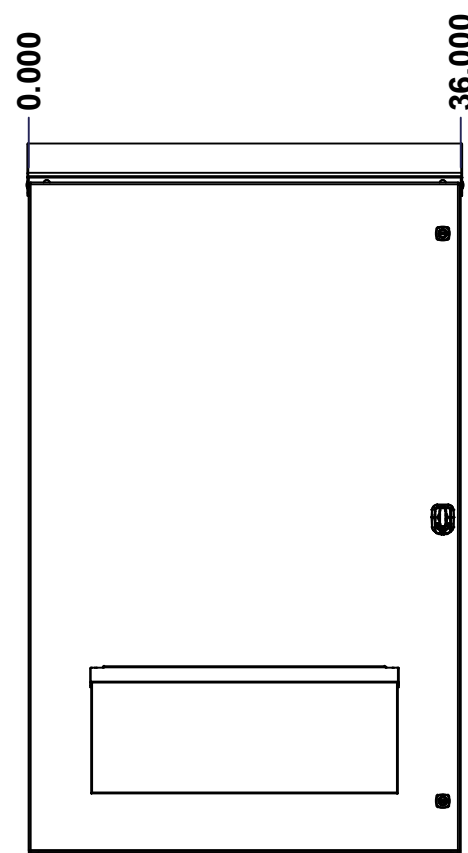

FRONT

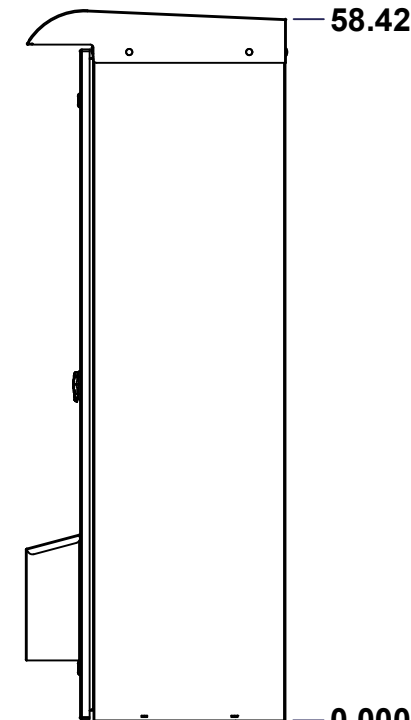

RIGHT

No.	Revisions	Date	By/Par

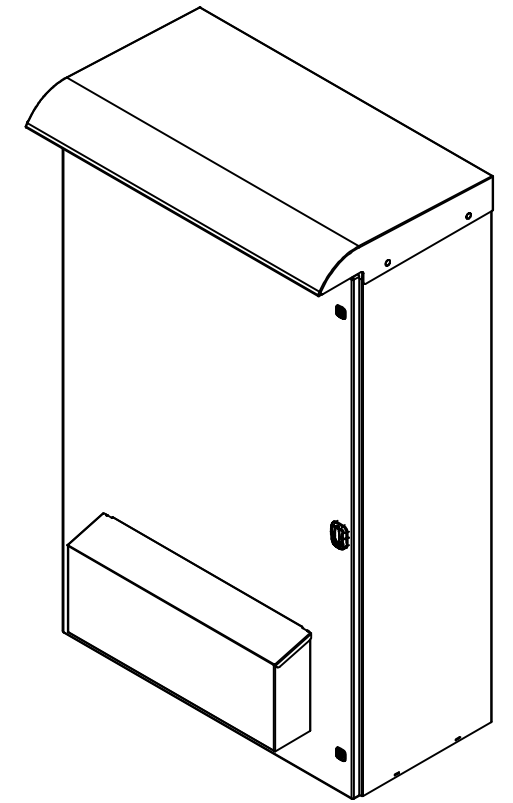

Isometric View



Tél: (450) 979-4373
 Fax: (450) 979-4626
www.exmweb.com

Flatness
Aplatissement

Max 3.0mm

Projection



Customer Client	Date
Drawn By Dessiné Par BoxCad: BoxCad	Date 03-Mar-22
Material Matière 14 Ga Cold Rolled A1008 CS Type B (1.7mm)	

Color Couleur White RAL9003 (Over Primer STK-P-04752)	Finish Fini Rough Textured
---	-------------------------------

Description 5300EWB 56" x 36" x 16" Assembly	Detail Rev.
---	-------------

Part Number Numéro Pièce 5300EWB563616	Rev. 0	1 9
--	---------------	--------

SEE BILL OF MATERIAL ON LAST PAGE

This drawing is confidential and must not be reproduced or used without the consent of EXM

Ce dessin est confidentiel et ne doit pas être reproduit ou utilisé sans le consentement de EXM

NOTE	
ITEM	DESCRIPTION
1	NEMA 3, 3R Enclosure (IP64)
2	C/W Powdura® Epoxy Powder Coating Primer
3	C/W Standard ground studs on box and cover
4	W/O Standard door stiffener
5	W/O Inner panel
6	C/W Standard inner panel mounting studs
7	C/W 01141.9-00 Included (Installed)

No.	Revisions	Date	By/Par

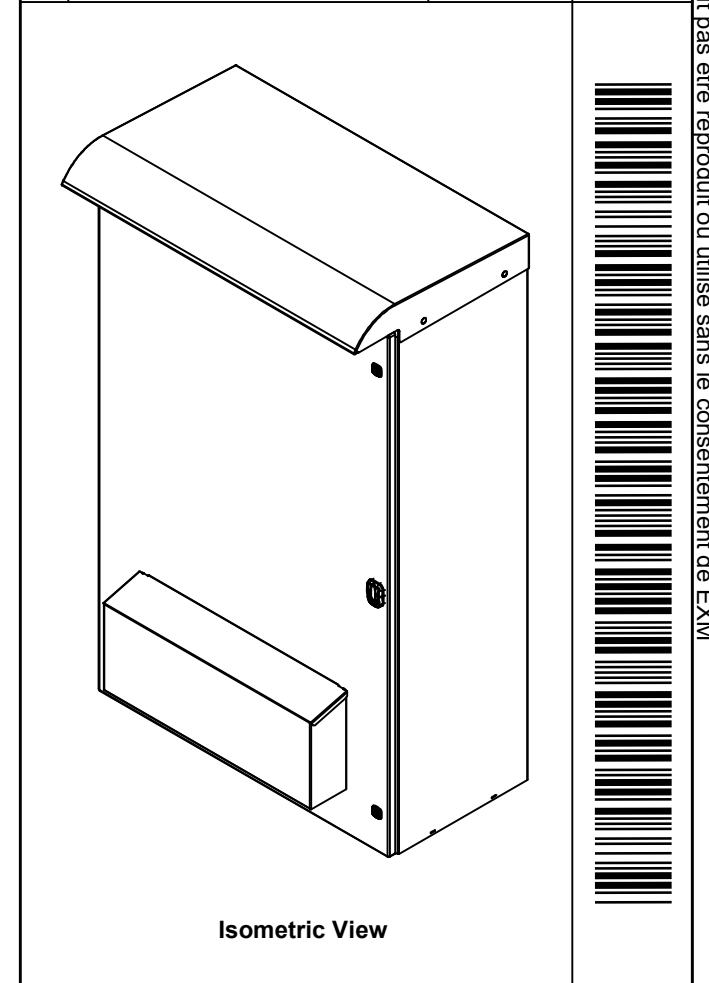

PACKING		
ITEM	QTY	DESCRIPTION
Cardboard sleeve	2	Top and Bottom
Cardboard strip	2	Between back of enclosure and inner panel
Plastic bag	1	To protect cover surface and inside gasket
Cardboard corner	4	To reinforced for the plastic strap tightening
Plastic strap - Black	2	To Squeeze 2 cardboard sleeve together
Packaging label	3	White label with PN
Plastic strap- Green	2	To secure the enclosure to the wood pallet
Wood Pallet	1	2" deeper and 3" larger than enclosure size

Qty	Part Number	Rev	Description
4	STK-Q-04050-10	8	M6 x 10mm Hexagon Socket Head Machine Screw with Nyseal
1	5300EWB563616C	0	5300EWB 56" x 36" x 16" Cover
1	5300EWB563616B	0	5300EWB 56" x 36" x 16" Body
Parts List			

<p>Tél: (450) 979-4373 Fax: (450) 979-4626 www.exmweb.com</p>	Flatness Aplatissement Max 3.0mm
	Projection
Customer Client	Date
Drawn By Dessiné Par BoxCad: BoxCad	Date 03-Mar-22
Material Matière 14 Ga Cold Rolled A1008 CS Type B (1.7mm)	
Color Couleur White RAL9003 (Over Primer STK-P-04752)	Finish Fini Rough Textured
Description 5300EWB 56" x 36" x 16" Assembly	Detail Rev.
Part Number Numéro Pièce 5300EWB563616	Rev. 0
	2 9

This drawing is confidential and must not be reproduced or used without the consent of EXM

Ce dessin est confidentiel et ne doit pas être reproduit ou utilisé sans le consentement de EXM

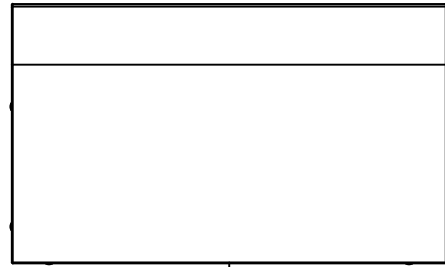

TOP

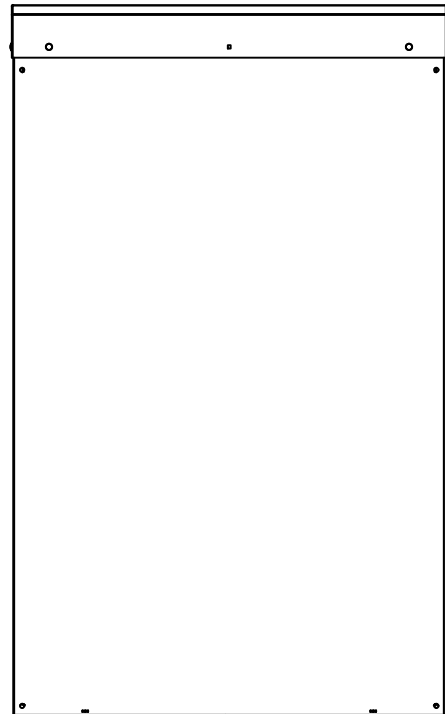

BACK



BOTTOM

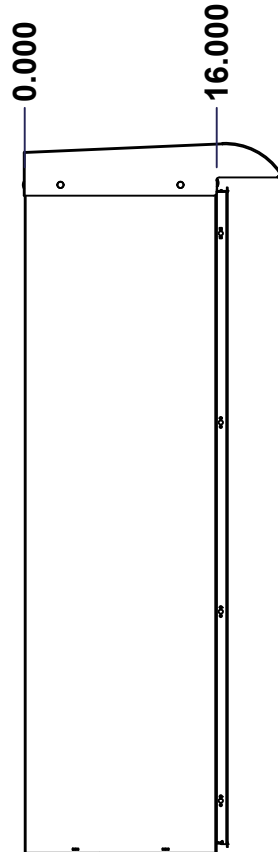

LEFT

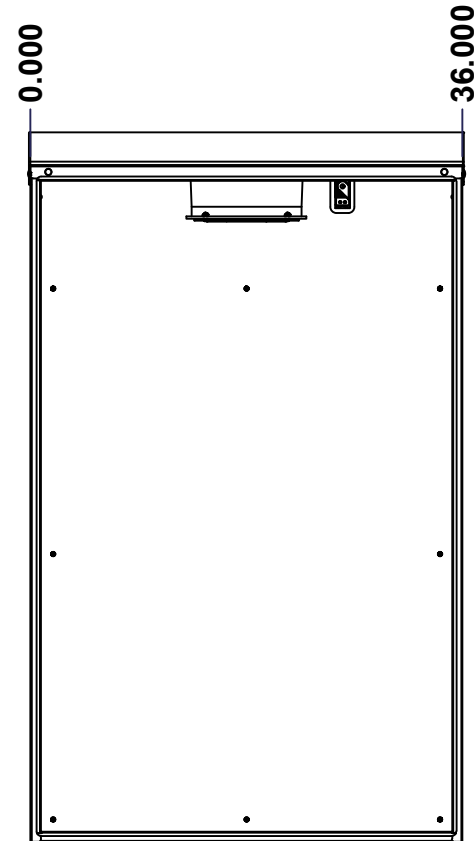

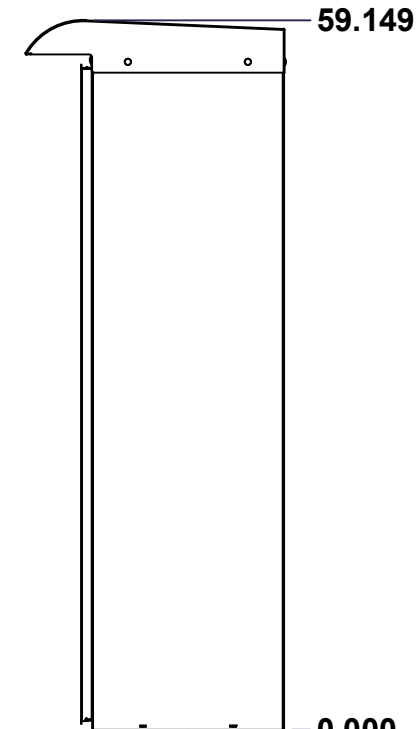

FRONT

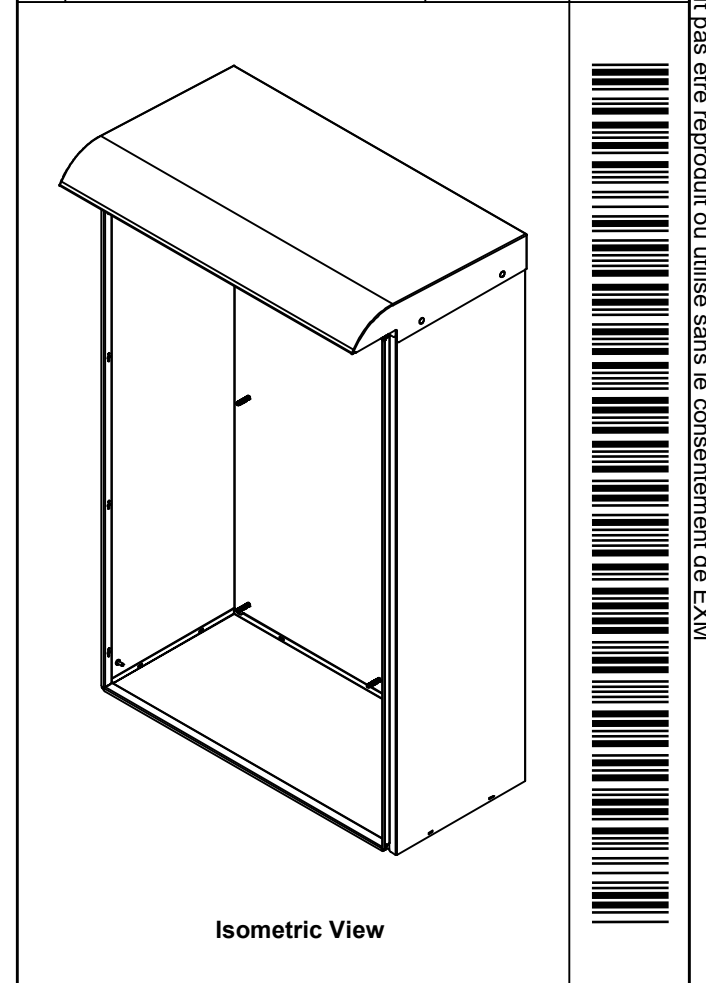

RIGHT

No.	Revisions	Date	By/Par



 Tél: (450) 979-4373 Fax: (450) 979-4626 www.exmweb.com		Flatness Aplatissement	
		Max 3.0mm	
Customer Client		Date	
Drawn By Dessiné Par BoxCad: BoxCad		Date 03-Mar-22	
Material Matière 14 Ga Cold Rolled A1008 CS Type B (1.7mm)			
Color Couleur White RAL9003 (Over Primer STK-P-04752)		Finish Fini Rough Textured	
Description 5300EWB 56" x 36" x 16" Body			Detail Rev.
Part Number Numéro Pièce 5300EWB563616B		Rev. 0	3 9

SEE BILL OF MATERIAL ON LAST PAGE

This drawing is confidential and must not be reproduced or used without the consent of EXM

Ce dessin est confidentiel et ne doit pas être reproduit ou utilisé sans le consentement de EXM

STANDARD FEATURES ARE NOT LISTED IN THIS HOLE TABLE			
HOLE TABLE - LEFT VIEW (CUSTOM FEATURE ONLY)			
CUT-OUT	XDIM	YDIM	DESCRIPTION
1	14.500	2.000	GND STUD M6 x 16mm (Inside)

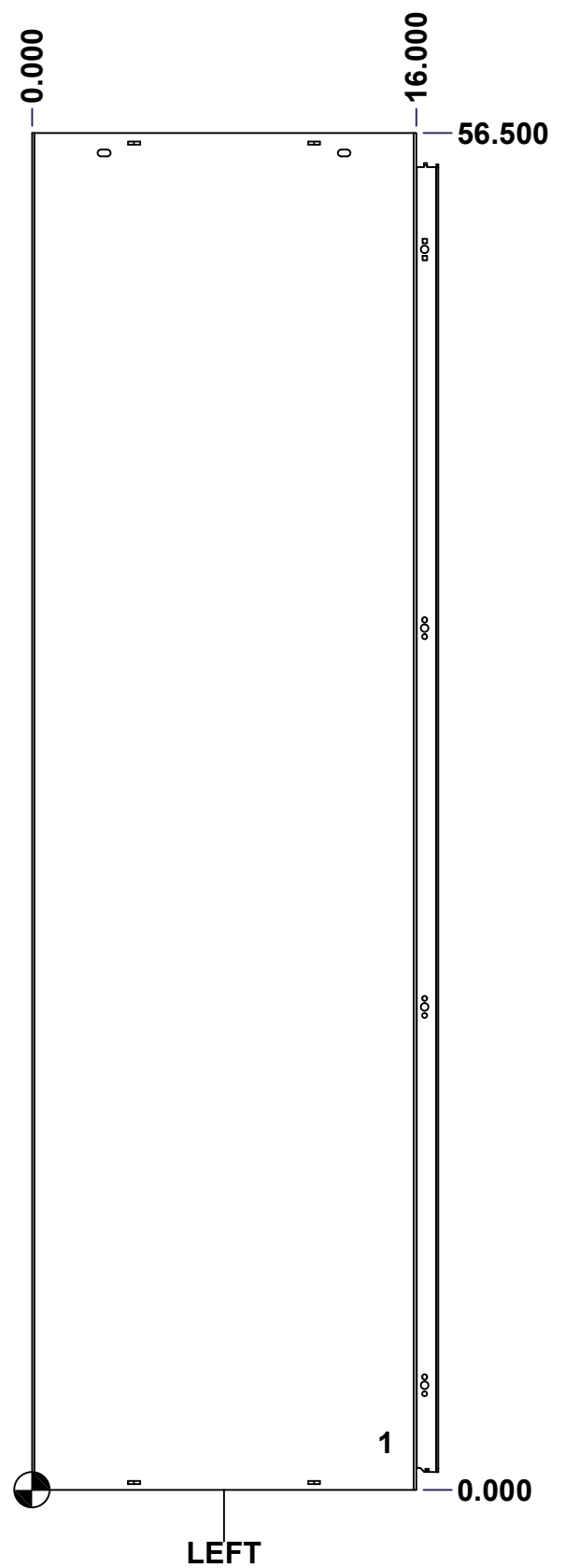

	Description	Status	
	5300EWB 56" x 36" x 16" Body	(NULL)	
	Part Number Numéro Pièce	Rev.	
	5300EWB563616B	0	4 9

This drawing is confidential and must not be reproduced or used without the consent of EXM

Ce dessin est confidentiel et ne doit pas être reproduit ou utilisé sans le consentement de EXM

STANDARD FEATURES ARE NOT LISTED IN THIS HOLE TABLE

HOLE TABLE - BACK VIEW (CUSTOM FEATURE ONLY)

CUT-OUT	XDIM	YDIM	DESCRIPTION
1	1.875	1.875	IP STUD M8 x 35mm (Inside)
2	1.875	46.125	IP STUD M8 x 35mm (Inside)
3	34.125	46.125	IP STUD M8 x 35mm (Inside)
4	34.125	1.875	IP STUD M8 x 35mm (Inside)
5	1.875	24.000	IP STUD M8 x 35mm (Inside)
6	34.125	24.000	IP STUD M8 x 35mm (Inside)
7	18.000	1.875	IP STUD M8 x 35mm (Inside)
8	18.000	46.125	IP STUD M8 x 35mm (Inside)

9	35.250	0.750	RND Ø0.390
10	35.250	53.750	RND Ø0.390
11	0.750	53.750	RND Ø0.390
12	0.750	0.750	RND Ø0.390

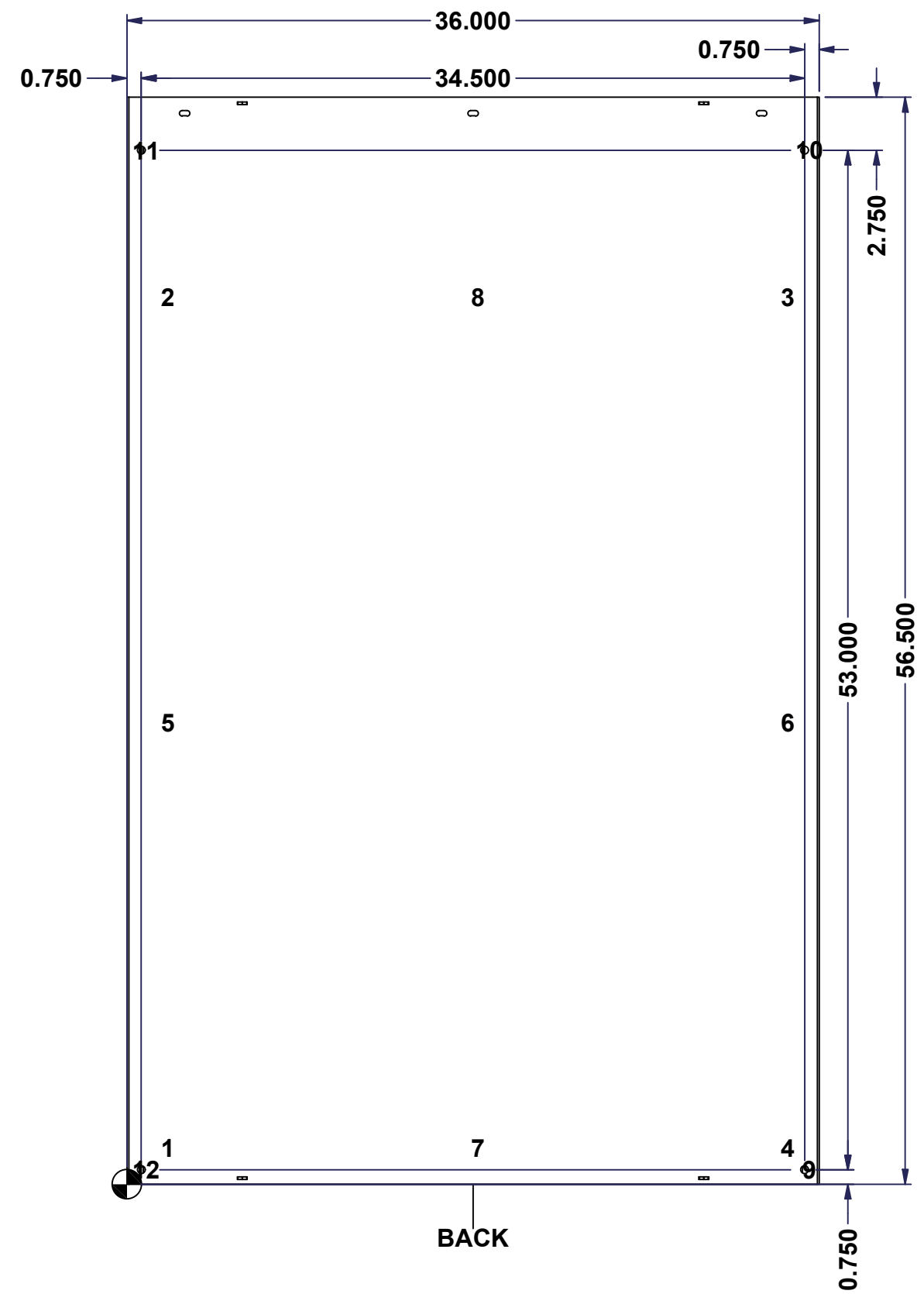

BACK

	Description	Status
	5300EWB 56" x 36" x 16" Body	(NULL)
	Part Number Numéro Pièce	Rev.
	5300EWB563616B	0
		5
		9

This drawing is confidential and must not be reproduced or used without the consent of EXM

Ce dessin est confidentiel et ne doit pas être reproduit ou utilisé sans le consentement de EXM

No.	Revisions	Date	By/Par

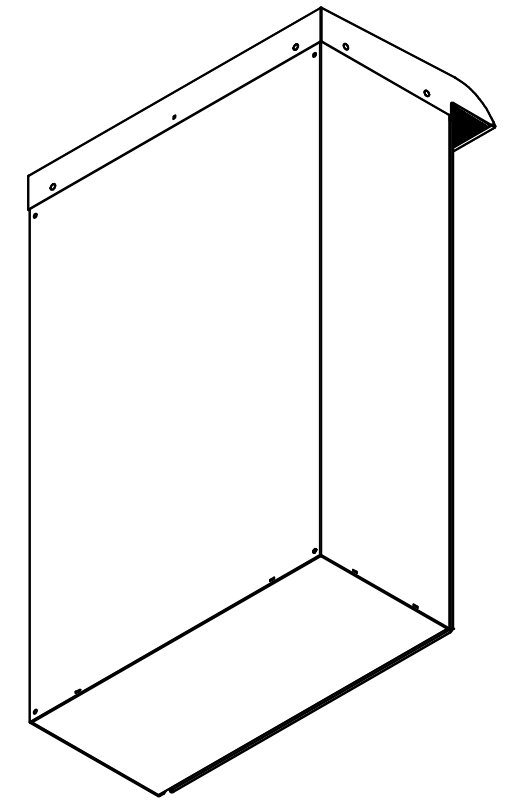

Isometric View



1	STK-Q-16080	0	Ground Stud M6 x 16mm Steel
1	STK-P-04752	0	Epoxy Primer Gray Powdura EAS6-C0000 (Bottom Layer)
1	STK-P-02401R	0	Powder Paint (White / Rough Textured)
1	01141.9-00	0	Small Thermostat (°F Normally Open)
1	5300EWB563616TH-P	0	5300EWB Thermostat Support Part
1	880FP325-585-115	5	Filter Fan - 325mm x 325mm (585CFM)
1	5300EWB563616GP-P	0	5300EWB 56" x 36" x 16" Fan Gland Plate Part
2	STK-Q-05020	5	M5 x 8mm Thread Rolling Screw
8	STK-Q-07220	1	M6 Nylon Insert Lock Nut
8	STK-Q-00260	1	M6 x 13mm Carriage Bolt
1	5300EWB563616T-P	0	5300EWB 36" x 16" Top Part
8	STK-Q-16005	0	Stud M8 x 35mm Steel
1	5300EWB563616BT-P	0	5300EWB 56" x 36" x 16" Bottom Part
1	5300EWB563616F-P	0	5300EWB 56" x 36" x 16" Front Part
1	5300EWB563616B-P	0	5300EWB 56" x 36" x 16" Body Part

Qty	Part Number	Rev	Description
Parts List			

Tél: (450) 979-4373 Fax: (450) 979-4626 www.exmweb.com	Flatness Aplatissement	Max 3.0mm
	Projection	
Customer Client	Date	
Drawn By Dessiné Par	BoxCad: BoxCad	Date 03-Mar-22
Material Matière	14 Ga Cold Rolled A1008 CS Type B (1.7mm)	
Color Couleur	White RAL9003 (Over Primer STK-P-04752)	Finish Fini
		Rough Textured
Description	Detail Rev.	
5300EWB 56" x 36" x 16" Body		
Part Number Numéro Pièce	Rev.	6
5300EWB563616B	0	9

This drawing is confidential and must not be reproduced or used without the consent of EXM

Ce dessin est confidentiel et ne doit pas être reproduit ou utilisé sans le consentement de EXM

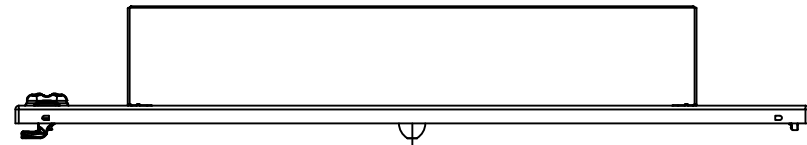

TOP

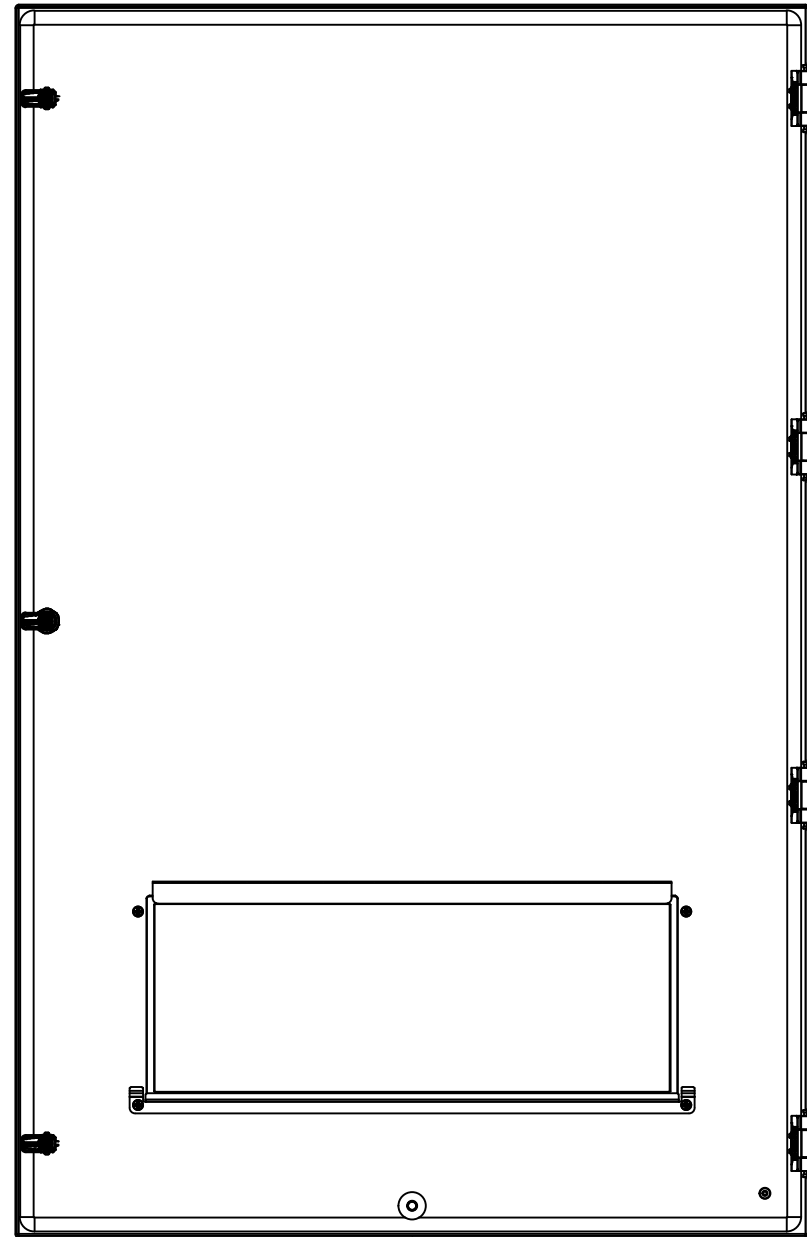

BACK

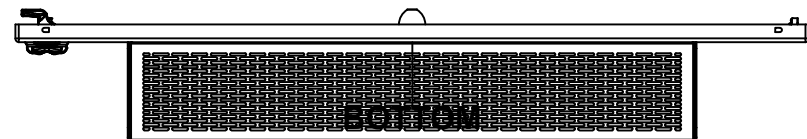

BOTTOM

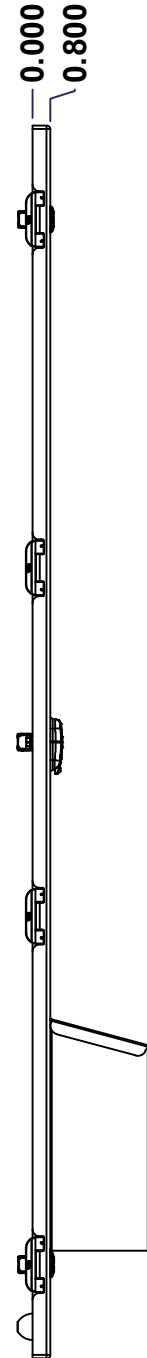

LEFT

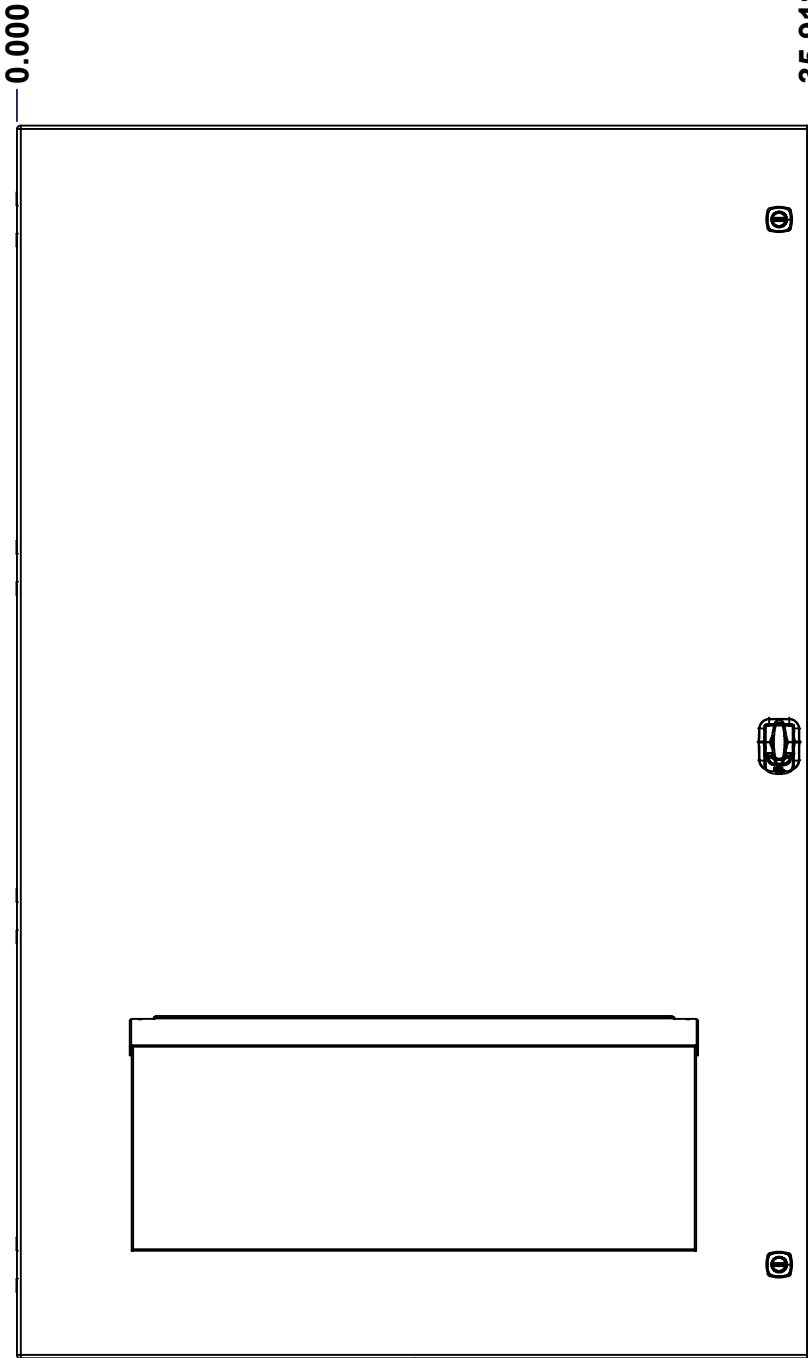

FRONT

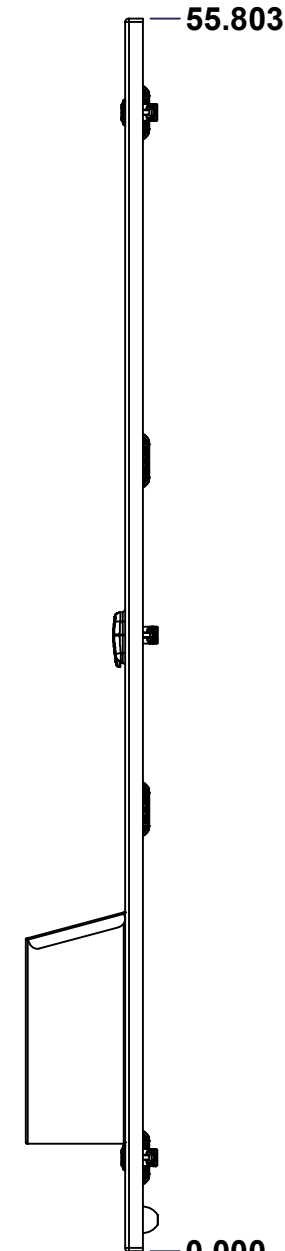

RIGHT

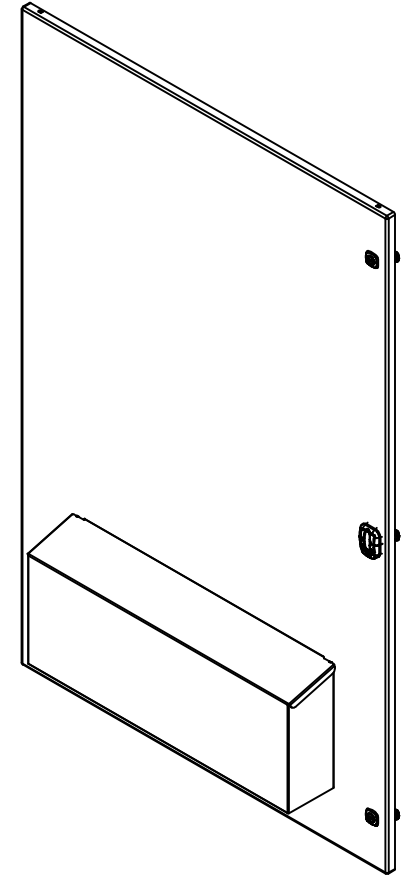

Isometric View

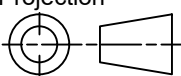

No.	Revisions	Date	By/Par

 Tél: (450) 979-4373 Fax: (450) 979-4626 www.exmweb.com		Flatness Aplatissement Max 3.0mm Projection 
Customer Client	Date	
Drawn By Dessiné Par	BoxCad: BoxCad	Date 03-Mar-22
Material Matière	14 Ga Cold Rolled A1008 CS Type B (1.7mm)	
Color Couleur	White RAL9003 (Over Primer STK-P-04752)	Finish Fini Rough Textured
Description	Detail Rev.	
5300EWB 56" x 36" x 16" Cover		
Part Number Numéro Pièce	Rev. 0	7 9
5300EWB563616C		

SEE BILL OF MATERIAL ON LAST PAGE

This drawing is confidential and must not be reproduced or used without the consent of EXM

Ce dessin est confidentiel et ne doit pas être reproduit ou utilisé sans le consentement de EXM

STANDARD FEATURES ARE NOT LISTED IN THIS HOLE TABLE

HOLE TABLE - FRONT VIEW (CUSTOM FEATURE ONLY)

CUT-OUT	XDIM	YDIM	DESCRIPTION
1	17.959	1.435	STUD M6 x 18mm (Inside)

2	2.000	2.000	GND STUD M6 x 16mm (Inside)
3	34.494	51.553	LOCK 880 SCQ4-SL @ 0.0°
4	34.494	27.902	LOCK 880 SCQ4PL-SL @ 0.0°
5	34.494	4.250	LOCK 880 SCQ4-SL @ 0.0°

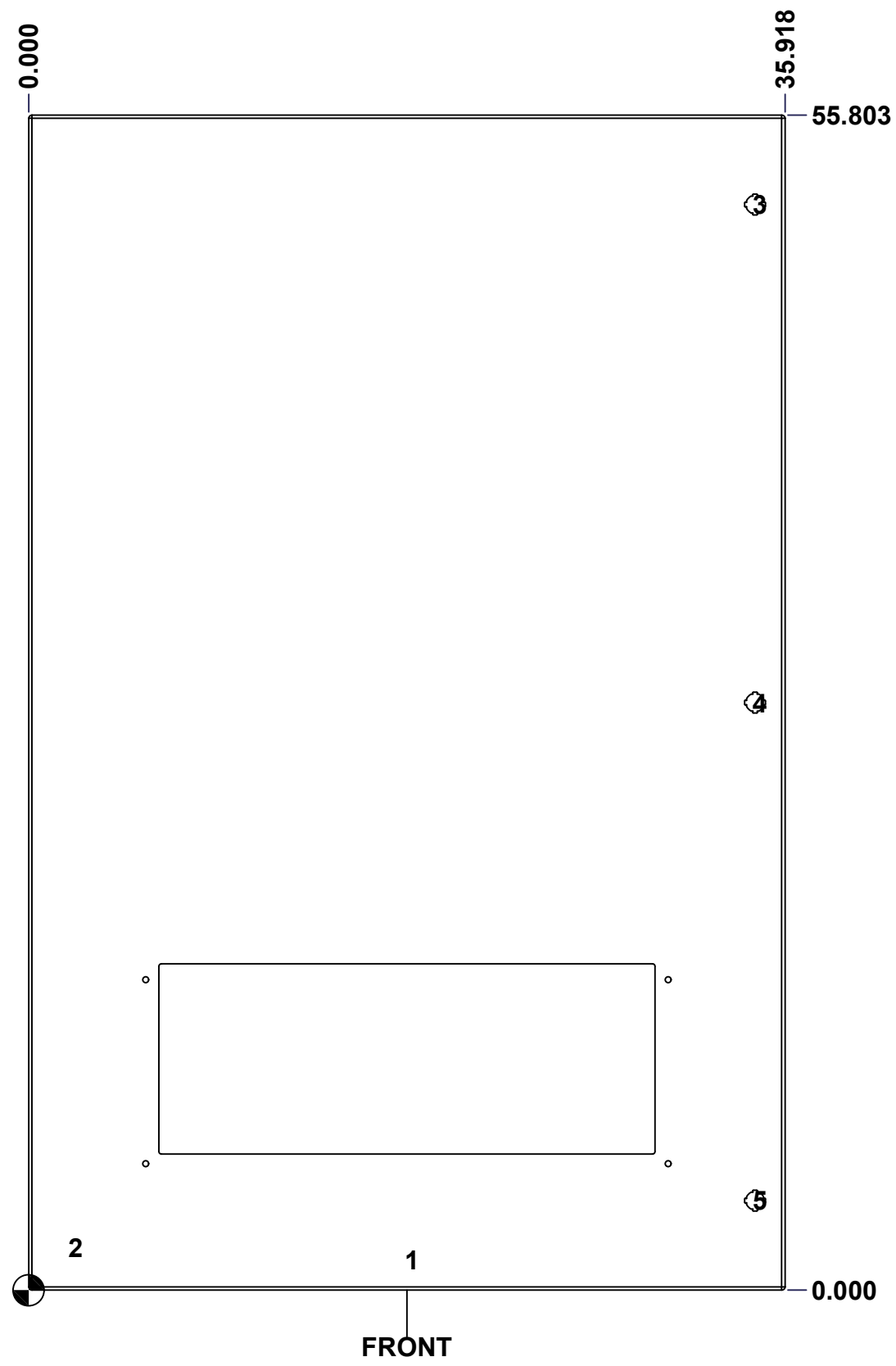

	Description	Status
	5300EWB 56" x 36" Cover	(NULL)
Part Number Numéro Pièce 5300EWB563616C	Rev.	8
	0	9

This drawing is confidential and must not be reproduced or used without the consent of EXM

Ce dessin est confidentiel et ne doit pas être reproduit ou utilisé sans le consentement de EXM

No.	Revisions	Date	By/Par

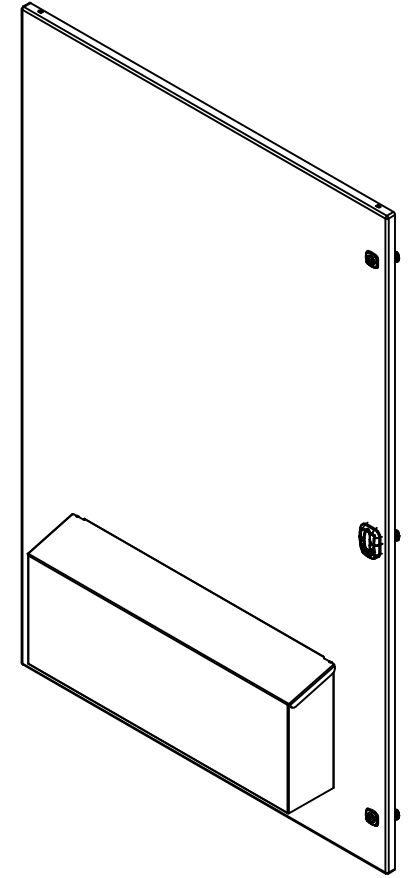

Isometric View



1	880 SCQ4PL-SL	3	5412 ES Padlockable 1/4 Turn Lock
2	STK-K-12500	18	5412 ES 1/4 Turn Lock
1	STK-Q-16080	0	Ground Stud M6 x 16mm Steel
1	STK-P-04752	0	Epoxy Primer Gray Powdura EAS6-C0000 (Bottom Layer)
1	STK-P-02401R	0	Powder Paint (White / Rough Textured)
1	5300EWB563616LPF	0	Filter 24.062" x 9.250"
1	5300EWB563616FPH585	0	5300EWB 56" x 36" x 16" Rain Hood
1	STK-Q-46515	3	5412 ES Door Support with Brass Insert
1	STK-Q-16055	1	M6 x 18mm Stud (No Paint Cap Required)
1	5300EWB563616G	0	5300EWB 56" x 36" Cover Gasket Part
4	STK-K-09800	10	5412 ES Hinge with 2 Captive Hinge Pins
1	5300EWB563616C-P	0	5300EWB 56" x 36" Cover Part

Qty	Part Name	Rev	Description
Parts List			

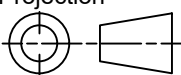
 Tél: (450) 979-4373 Fax: (450) 979-4626 www.exmweb.com		Flatness Aplatissement Max 3.0mm Projection 
Customer Client	Date	
Drawn By Dessiné Par BoxCad: BoxCad	Date 03-Mar-22	
Material Matière 14 Ga Cold Rolled A1008 CS Type B (1.7mm)		
Color Couleur White RAL9003 (Over Primer STK-P-04752)	Finish Fini Rough Textured	
Description 5300EWB 56" x 36" x 16" Cover	Detail Rev.	
Part Number Numéro Pièce 5300EWB563616C	Rev. 0	9