

This drawing is confidential and must not be reproduced or used without the consent of EXM

Ce dessin est confidentiel et ne doit pas être reproduit ou utilisé sans le consentement de EXM

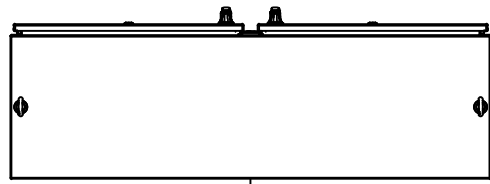

TOP

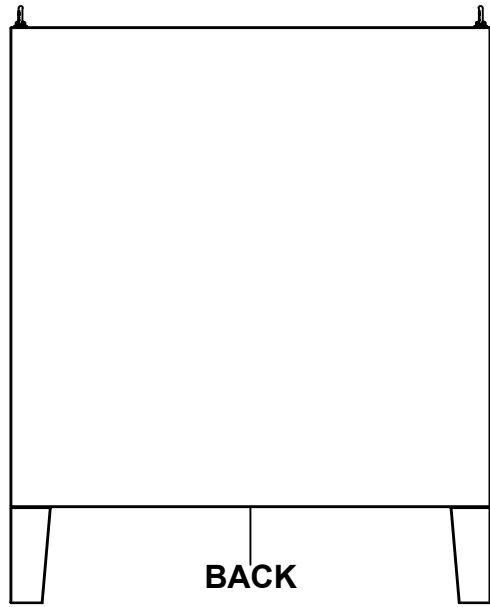

BACK

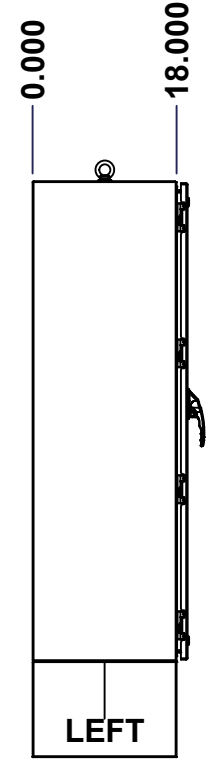

LEFT

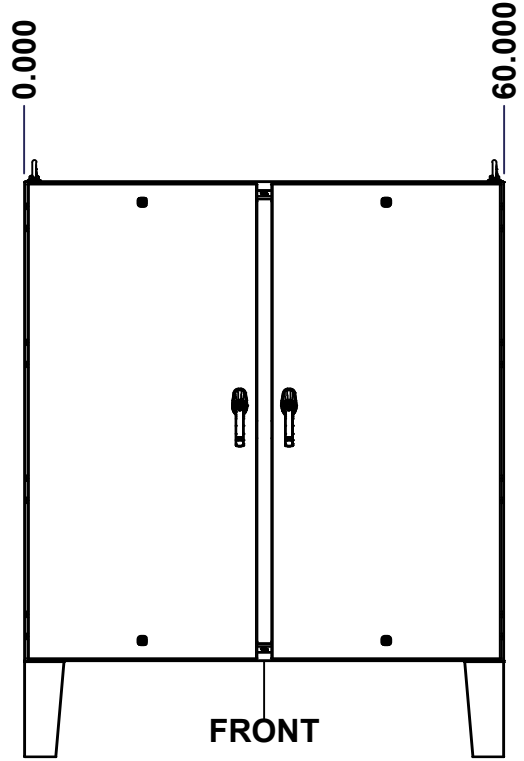

FRONT

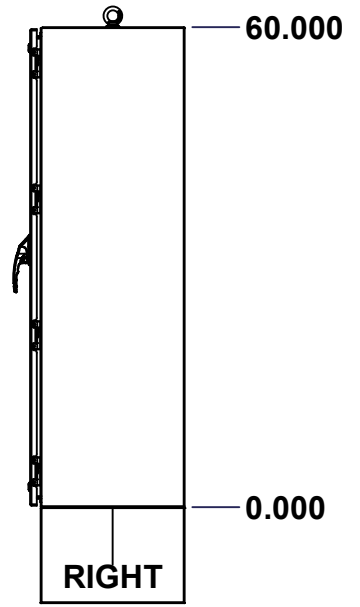

RIGHT

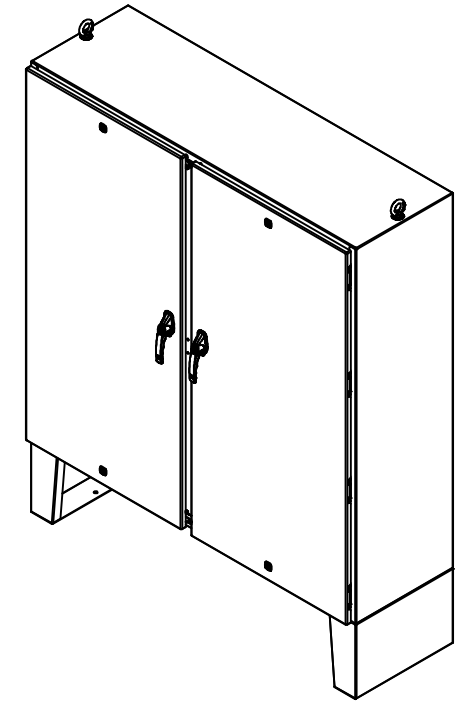

Isometric View

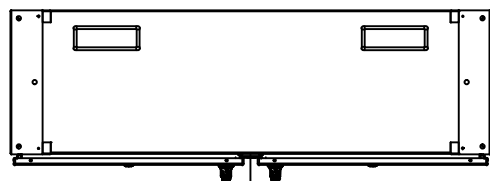

BOTTOM

No.	Revisions	Date	By/Par

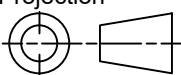
 Tél: (450) 979-4373 Fax: (450) 979-4626 www.exmweb.com		Flatness Aplatissement Max 3.0mm Projection 
Customer Client	Date	
Drawn By Dessiné Par	BoxCad: BoxCad	Date 21-Jan-26
Material Matière	12 Ga Cold Rolled A1008 CS Type B (2.5mm)	
Color Couleur	Asa-61 Grey	Finish Fini Smooth
Description	5412DDS 60" x 60" x 18" Assembly	
Part Number Numéro Pièce	Rev. 0	1 / 18

SEE BILL OF MATERIAL ON LAST PAGE

5412DDH606018

This drawing is confidential and must not be reproduced or used without the consent of EXM

Ce dessin est confidentiel et ne doit pas être reproduit ou utilisé sans le consentement de EXM

NOTE	
ITEM	DESCRIPTION
1	NEMA 4, 12 Enclosure (IP66)
2	C/W Standard ground studs on box and cover
3	W/O Standard door stiffener
4	C/W Standard inner panel (Included)
5	C/W Standard inner panel mounting studs
6	C/W Eyebolts sold separately (Installed by EXM)
7	C/W Special handle sold separately (Kit)
8	C/W Mounting feet sold separately (Installed)
9	C/W Struts Welded (Included)
10	C/W Interlock Kit (Installed by EXM)

No.	Revisions	Date	By/Par

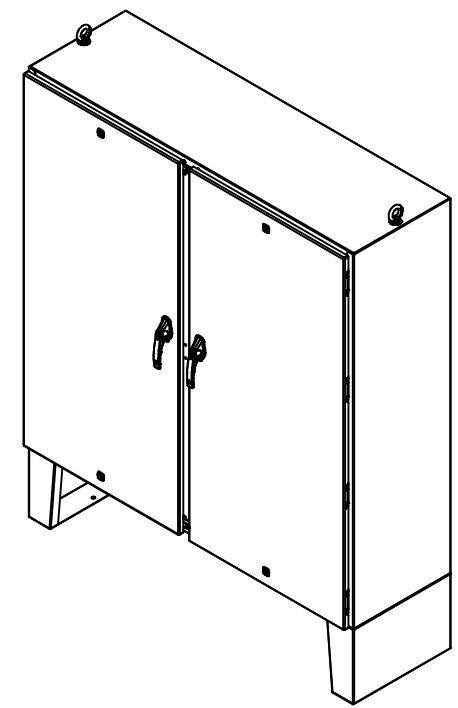

Isometric View

PACKING		
ITEM	QTY	DESCRIPTION
Cardboard sleeve	2	Top and Bottom
Cardboard strip	2	Between back of enclosure and inner panel
Plastic bag	1	To protect cover surface and inside gasket
Cardboard corner	4	To reinforced for the plastic strap tightening
Plastic strap - Black	2	To Squeeze 2 cardboard sleeve together
Packaging label	3	White label with PN
Plastic strap- Green	2	To secure the enclosure to the wood pallet
Wood Pallet	1	2" deeper and 3" larger than enclosure size

1	5412DDH606018MF	0	885 MFHD 12" x 18" Mounting Feet
8	STK-Q-07320	0	Flange Lock Nut M10
1	885SP6060G	0	885 SP6060G Inner Panel
1	880INTI	4	880 INTI - Interlock Post Kit
1	880EB14	2	Eye Bolt M14 (Pack of 2)
8	STK-Q-07620	0	M10 Plastic Spacer 0.875"
1	5412DDH606018FD	0	5412DDS 60" x 60" Master Door
1	5412DDH606018LD	0	5412DDS 60" x 60" Slave Door
1	5412DDH606018B	0	5412DDS 60" x 60" x 18" Body
2	5412DDH606018GP	0	5412DDS Gland Plate
8	STK-Q-04050-10	8	M6 x 10mm Hexagon Socket Head Machine Screw with Nyseal
Qty	Part Number	Rev	Description
Parts List			

	Tél: (450) 979-4373 Fax: (450) 979-4626 www.exmweb.com	Flatness Aplatissement Max 3.0mm Projection
	Customer Client	Date
Drawn By Dessiné Par	BoxCad: BoxCad	Date 21-Jan-26
Material Matière	12 Ga Cold Rolled A1008 CS Type B (2.5mm)	
Color Couleur	Asa-61 Grey	Finish Fini Smooth
Description 5412DDS 60" x 60" x 18" Assembly		Detail Rev.
Part Number Numéro Pièce 5412DDH606018		Rev. 0 2 18

This drawing is confidential and must not be reproduced or used without the consent of EXM

Ce dessin est confidentiel et ne doit pas être reproduit ou utilisé sans le consentement de EXM

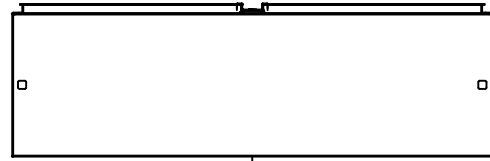

TOP

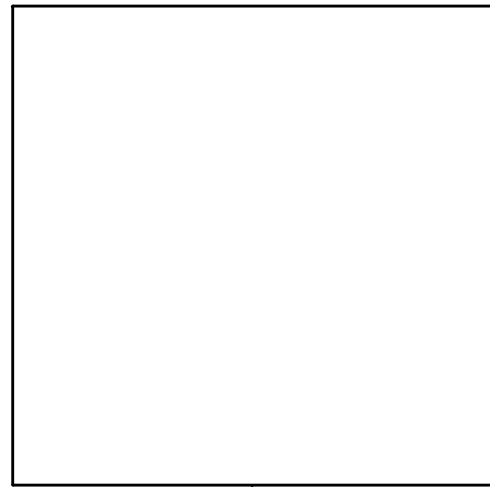

BACK

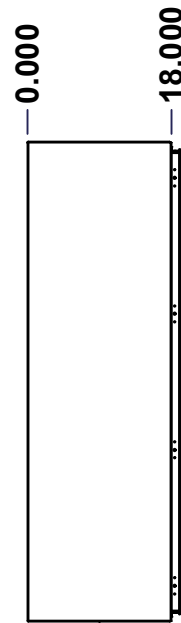

LEFT

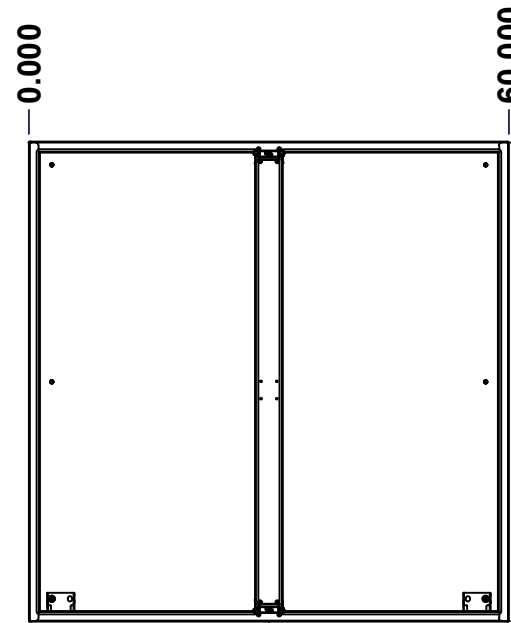

FRONT

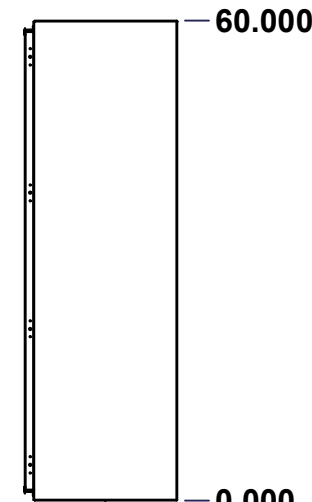

RIGHT



BOTTOM

No.	Revisions	Date	By/Par

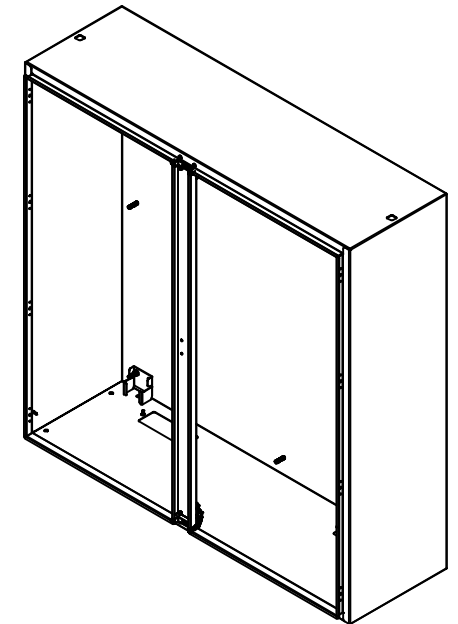

Isometric View



Tél: (450) 979-4373
 Fax: (450) 979-4626
www.exmweb.com

Flatness
Aplatissement

Max 3.0mm

Projection



Customer Client	Date
Drawn By Dessiné Par BoxCad: BoxCad	Date 21-Jan-26
Material Matière 12 Ga Cold Rolled A1008 CS Type B (2.5mm)	
Color Couleur Asa-61 Grey	Finish Fini Smooth
Description 5412DDS 60" x 60" x 18" Body	Detail Rev.
Part Number Numéro Pièce 5412DDH606018B	Rev. 0

SEE BILL OF MATERIAL ON LAST PAGE

This drawing is confidential and must not be reproduced or used without the consent of EXM

Ce dessin est confidentiel et ne doit pas être reproduit ou utilisé sans le consentement de EXM

STANDARD FEATURES ARE NOT LISTED IN THIS HOLE TABLE

HOLE TABLE - TOP VIEW (CUSTOM FEATURE ONLY)

CUT-OUT	XDIM	YDIM	DESCRIPTION
1	45.000	14.000	Struts CR400 21.500" (Inside)
2	15.000	14.000	Struts CR400 21.500" (Inside)
3	45.000	14.929	STUDS M6 x 10mm (Inside)
4	55.866	14.000	STUDS M6 x 10mm (Inside)
5	15.000	14.929	STUDS M6 x 10mm (Inside)
6	25.866	14.000	STUDS M6 x 10mm (Inside)

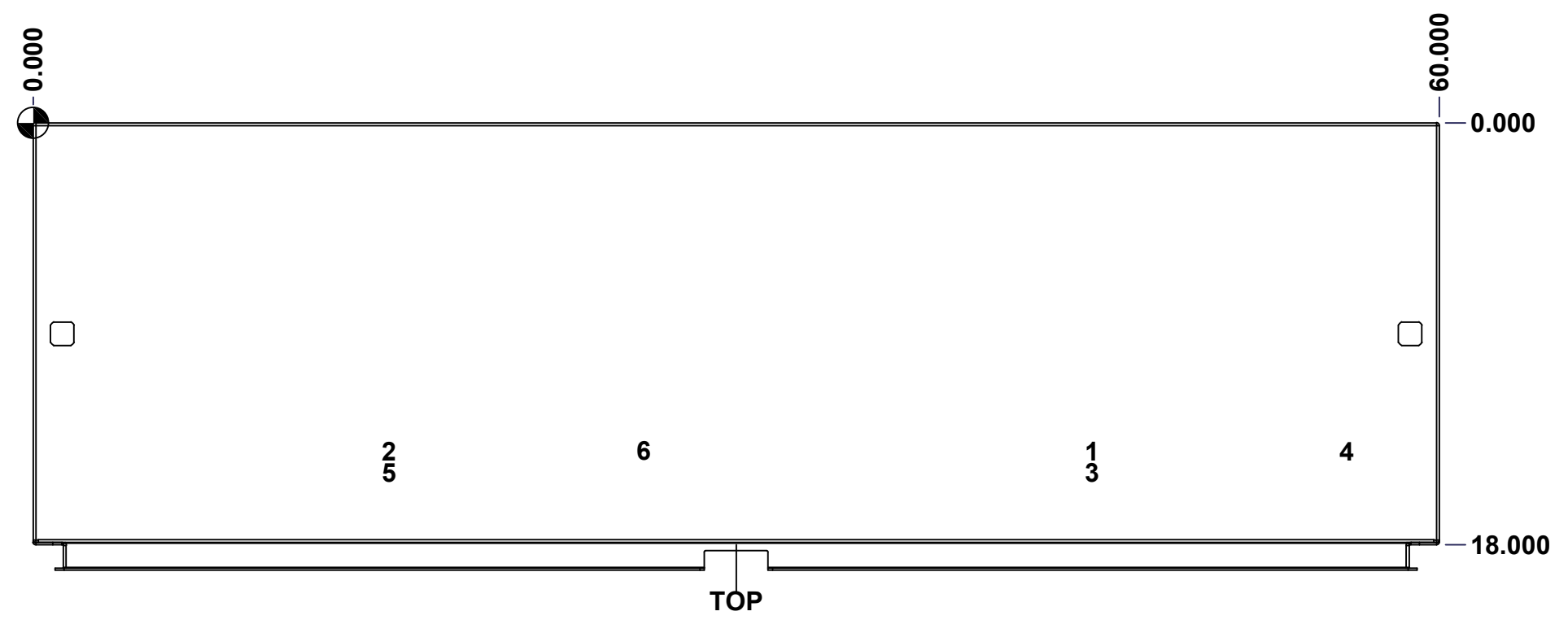

	Description	Status
	5412DDS 60" x 60" x 18" Body	(NULL)
	Part Number Numéro Pièce	Rev.
	5412DDH606018B	0 / 4
		18

This drawing is confidential and must not be reproduced or used without the consent of EXM

Ce dessin est confidentiel et ne doit pas être reproduit ou utilisé sans le consentement de EXM

STANDARD FEATURES ARE NOT LISTED IN THIS HOLE TABLE			
HOLE TABLE - RIGHT VIEW (CUSTOM FEATURE ONLY)			
CUT-OUT	XDIM	YDIM	DESCRIPTION
1	16.500	3.375	GND STUD M6 x 16mm (Inside)

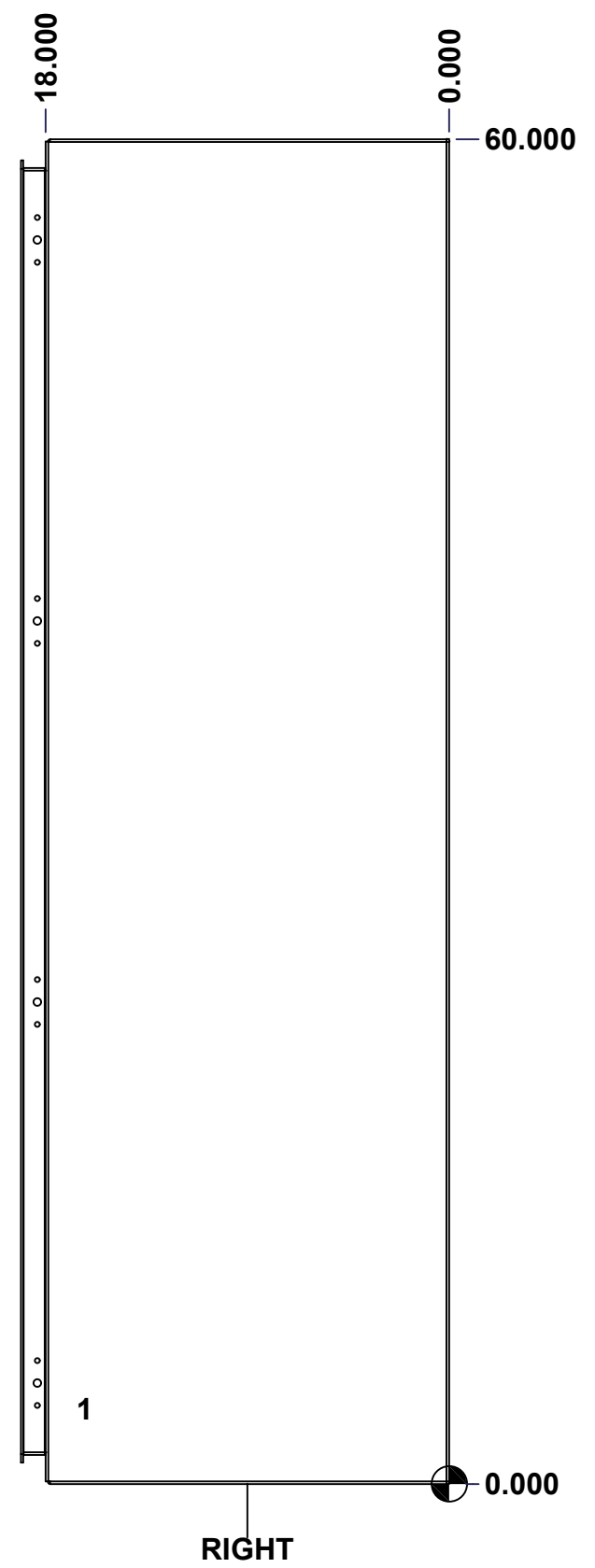

	Description	Status
	5412DDS 60" x 60" x 18" Body	(NULL)
	Part Number Numéro Pièce	Rev.
	5412DDH606018B	0 / 5
		18

This drawing is confidential and must not be reproduced or used without the consent of EXM

Ce dessin est confidentiel et ne doit pas être reproduit ou utilisé sans le consentement de EXM

STANDARD FEATURES ARE NOT LISTED IN THIS HOLE TABLE

HOLE TABLE - BOTTOM VIEW (CUSTOM FEATURE ONLY)

CUT-OUT	XDIM	YDIM	DESCRIPTION
1	7.375	3.500	GP STUD M6 x 16mm (Inside)
2	16.625	3.500	GP STUD M6 x 16mm (Inside)
3	43.375	3.500	GP STUD M6 x 16mm (Inside)
4	52.625	3.500	GP STUD M6 x 16mm (Inside)

5	4.000	1.000	RND Ø0.500
6	1.000	3.000	RND Ø0.500
7	1.000	15.000	RND Ø0.500
8	4.000	17.000	RND Ø0.500
9	56.000	1.000	RND Ø0.500
10	59.000	3.000	RND Ø0.500
11	59.000	15.000	RND Ø0.500
12	56.000	17.000	RND Ø0.500

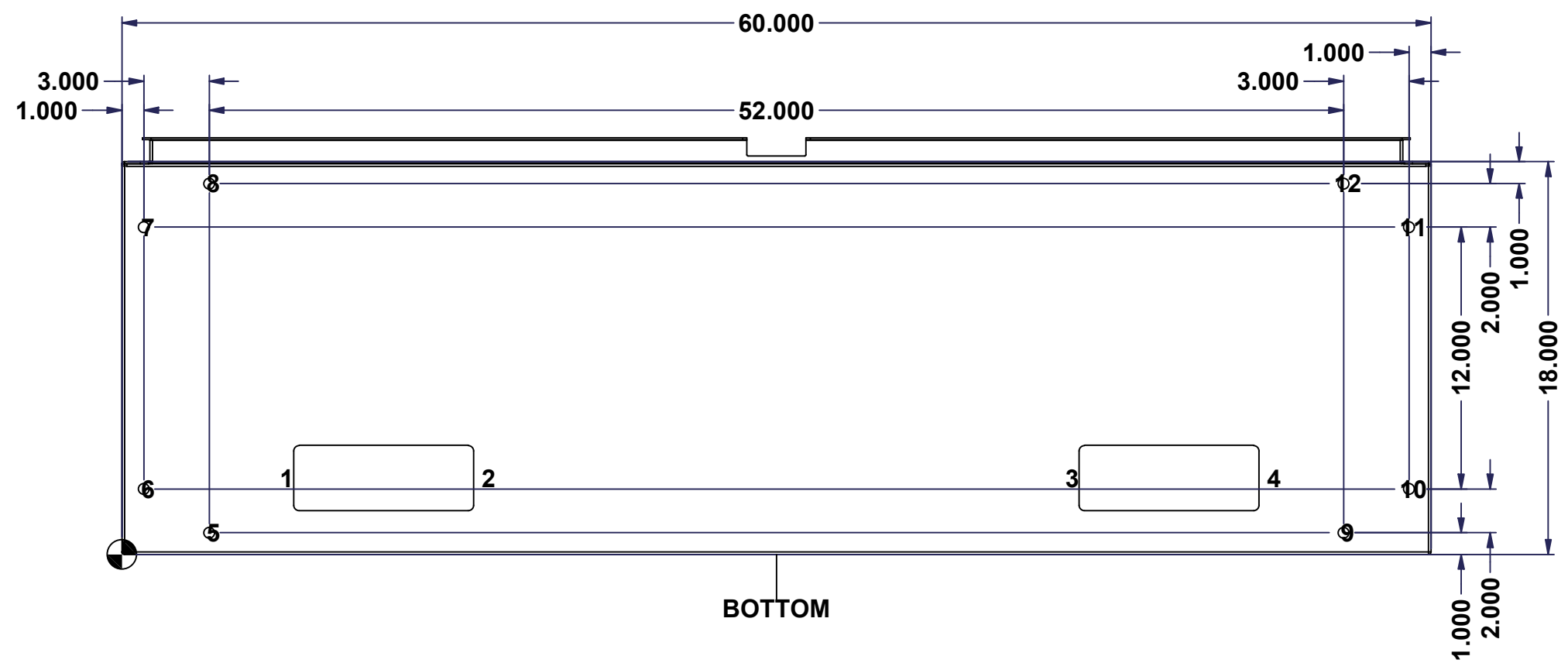

BOTTOM

	Description	Status
	5412DDS 60" x 60" x 18" Body	(NULL)
	Part Number Numéro Pièce	Rev.
	5412DDH606018B	0 / 6
		18

This drawing is confidential and must not be reproduced or used without the consent of EXM

Ce dessin est confidentiel et ne doit pas être reproduit ou utilisé sans le consentement de EXM

STANDARD FEATURES ARE NOT LISTED IN THIS HOLE TABLE			
HOLE TABLE - LEFT VIEW (CUSTOM FEATURE ONLY)			
CUT-OUT	XDIM	YDIM	DESCRIPTION
1	16.500	3.375	GND STUD M6 x 16mm (Inside)

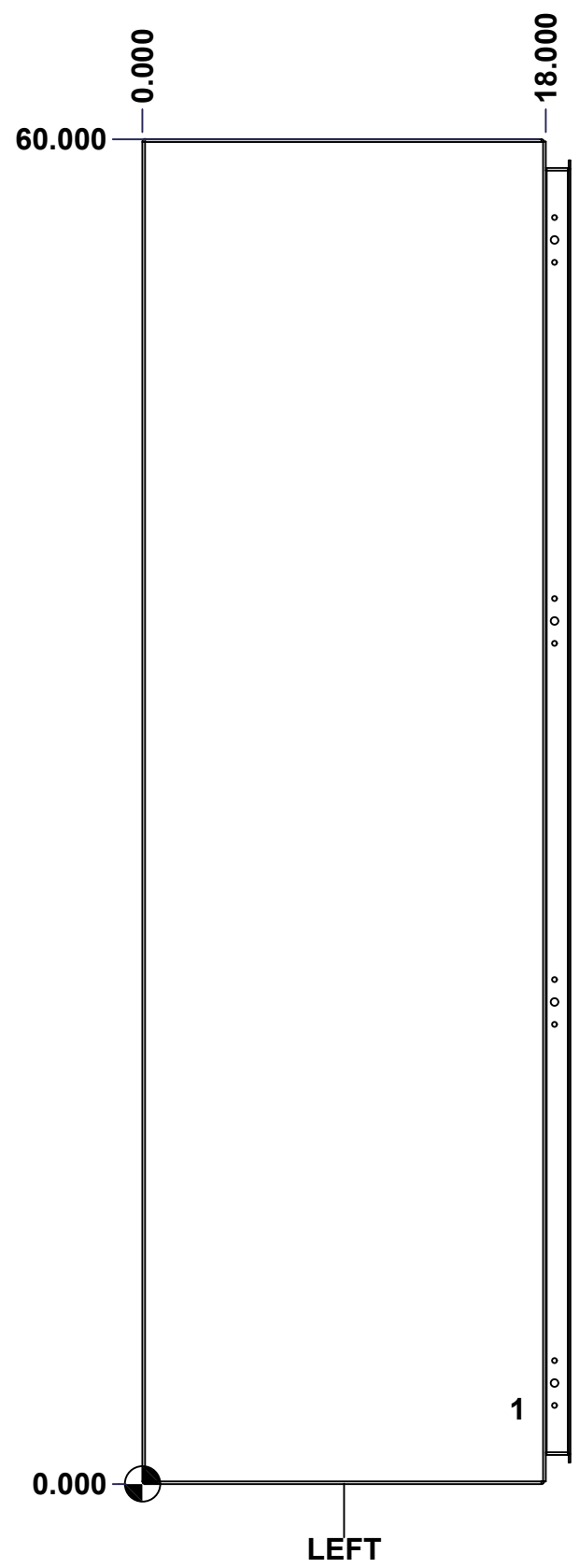

	Description	Status
	5412DDS 60" x 60" x 18" Body	(NULL)
Part Number Numéro Pièce 5412DDH606018B	Rev.	7
	0	18

This drawing is confidential and must not be reproduced or used without the consent of EXM

Ce dessin est confidentiel et ne doit pas être reproduit ou utilisé sans le consentement de EXM

STANDARD FEATURES ARE NOT LISTED IN THIS HOLE TABLE

HOLE TABLE - BACK VIEW (CUSTOM FEATURE ONLY)

CUT-OUT	XDIM	YDIM	DESCRIPTION
1	2.875	2.875	IP STUD M10 x 40mm (Inside)
2	57.125	2.875	IP STUD M10 x 40mm (Inside)
3	2.875	30.000	IP STUD M10 x 40mm (Inside)
4	57.125	30.000	IP STUD M10 x 40mm (Inside)
5	2.875	57.125	IP STUD M10 x 40mm (Inside)
6	57.125	57.125	IP STUD M10 x 40mm (Inside)
7	30.000	2.875	IP STUD M10 x 40mm (Inside)
8	30.000	57.125	IP STUD M10 x 40mm (Inside)

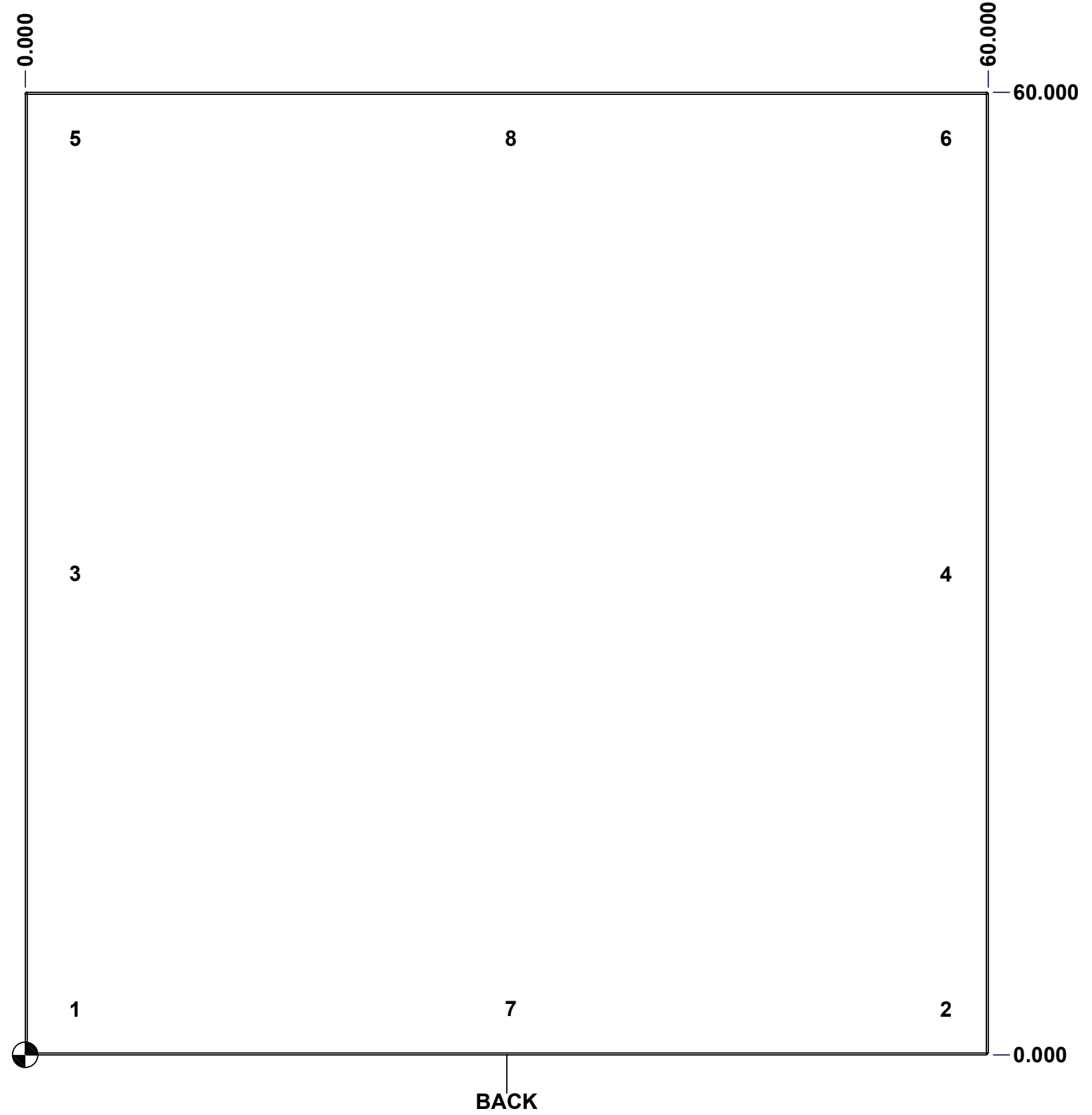

BACK

	Description	Status	
	5412DDS 60" x 60" x 18" Body	(NULL)	
	Part Number Numéro Pièce	Rev.	
	5412DDH606018B	0	8
			18

This drawing is confidential and must not be reproduced or used without the consent of EXM

Ce dessin est confidentiel et ne doit pas être reproduit ou utilisé sans le consentement de EXM

STANDARD FEATURES ARE NOT LISTED IN THIS HOLE TABLE

HOLE TABLE - CENTER VIEW (CUSTOM FEATURE ONLY)

CUT-OUT	XDIM	YDIM	DESCRIPTION
1	0.748	26.179	PEM FH-M6-15ZI (Inside)
2	0.748	28.305	PEM FH-M6-15ZI (Inside)
3	2.717	26.179	PEM FH-M6-15ZI (Inside)
4	2.717	28.305	PEM FH-M6-15ZI (Inside)

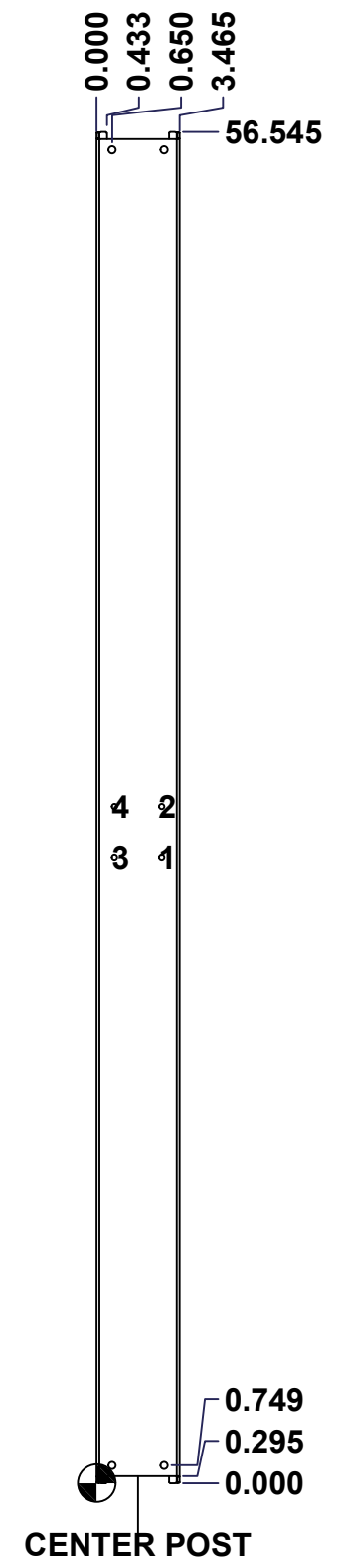

	Description	Status
	5412DDS 60" x 60" x 18" Body	(NULL)
Part Number Numéro Pièce 5412DDH606018B	Rev.	9
	0	18

This drawing is confidential and must not be reproduced or used without the consent of EXM

Ce dessin est confidentiel et ne doit pas être reproduit ou utilisé sans le consentement de EXM

No.	Revisions	Date	By/Par

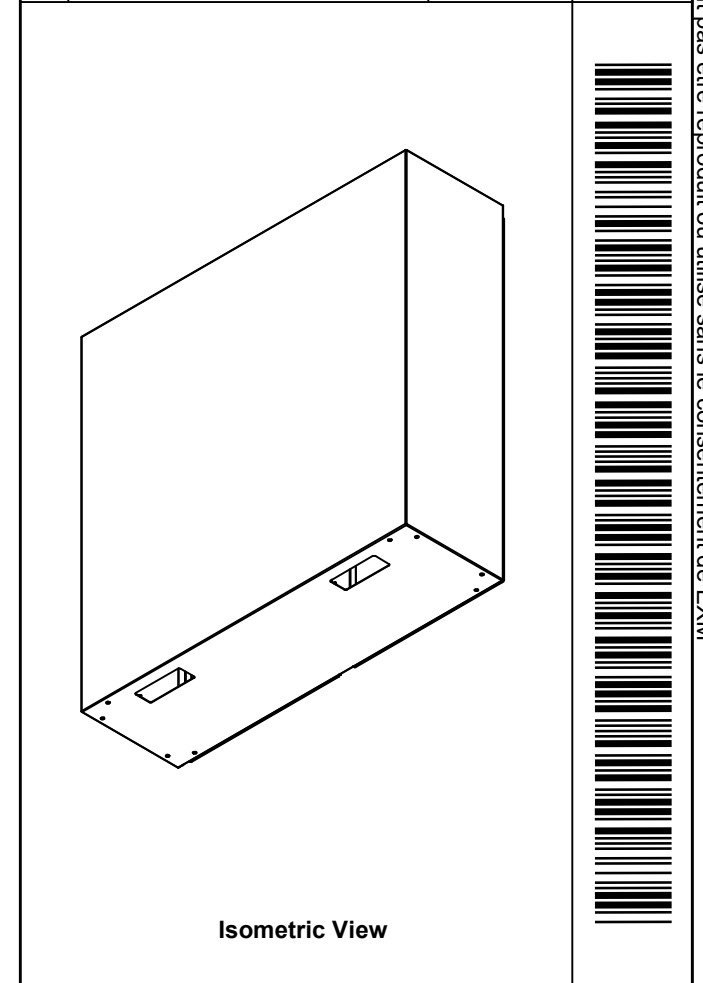

4	STK-Q-16030	0	Stud M6 x 10mm Steel
4	STK-PEM-FH-M6-15ZI	0	PEM Self-Clinching Stud M6 x 15.0mm
1	STK-P-02400S	0	Powder Paint (Asa-61 Grey / Smooth)
2	STK-Q-74900	0	Eyebolt Lifting Angle (8.750")
8	STK-Q-04056-12	0	M6 x 8mm Hexagon Socket Head Machine Screw with Nyseal
1	STK-K-75454	14	Center Post Freestanding Sealing Block with Latch Kit
1	5412DDH606018CP-P	0	5412DDS 60" Center Post Part
2	STK-Q-07320	0	Flange Lock Nut M10
2	STK-Q-07618	1	5500 Series Inner Panel Support Bracket
8	STK-Q-16100	0	Stud M10 x 40mm Steel
1	5412DDH606018B-P	0	5412DDS 60" x 60" Body Part
2	5412DDH606018_CR400 MS_21.5	0	Commercial Roll Mild Steel (21.5in long)
6	STK-Q-16080	0	Ground Stud M6 x 16mm Steel

Qty	Part Number	Rev	Description
Parts List			



Tél: (450) 979-4373
Fax: (450) 979-4626
www.exmweb.com

Flatness
Aplatissement
Max 3.0mm

Projection

Customer Client

Date

Drawn By / Dessiné Par: BoxCad: BoxCad

Date: 21-Jan-26

Material / Matière: 12 Ga Cold Rolled A1008 CS Type B (2.5mm)

Color / Couleur: Asa-61 Grey

Finish / Fini: Smooth

Description: 5412DDS 60" x 60" x 18" Body

Detail Rev.

Part Number / Numéro Pièce

5412DDH606018B

Rev. 10

0

18

This drawing is confidential and must not be reproduced or used without the consent of EXM

Ce dessin est confidentiel et ne doit pas être reproduit ou utilisé sans le consentement de EXM

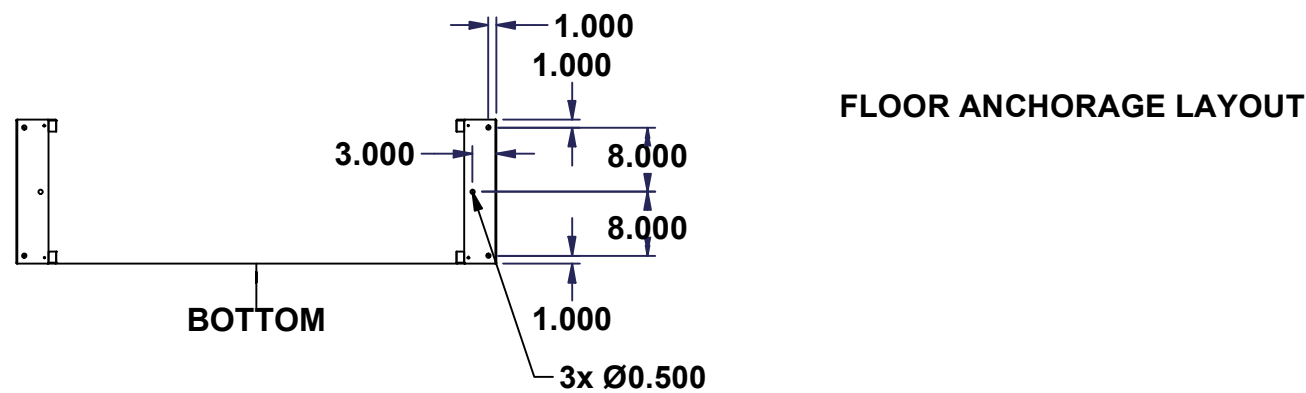
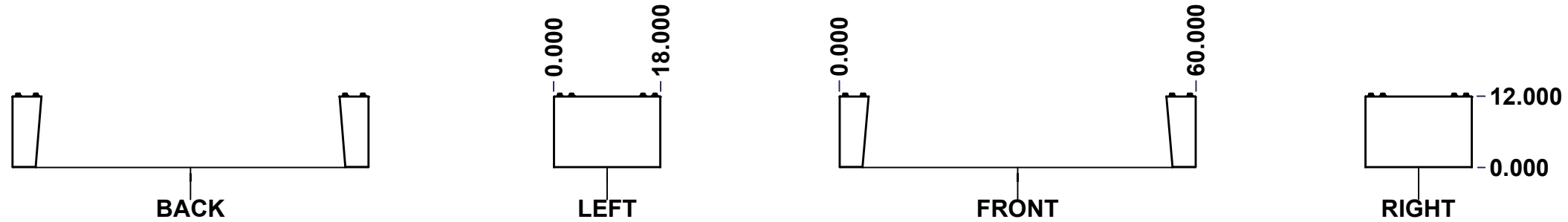
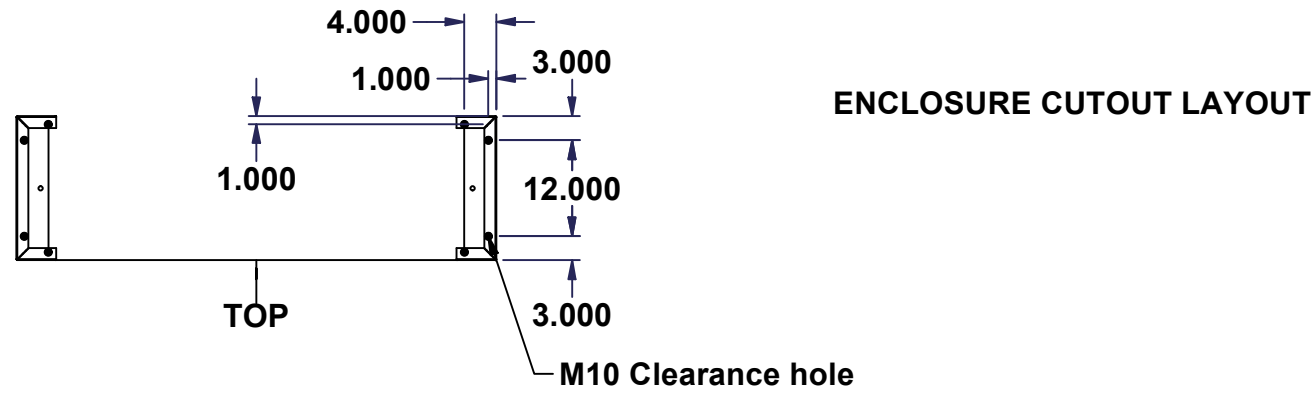

No.	Revisions	Date	By/Par

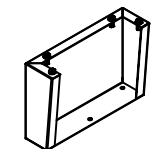
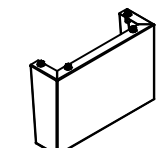
Isometric View





 Tél: (450) 979-4373 Fax: (450) 979-4626 www.exmweb.com		Flatness Aplatissement
		Max 3.0mm
Customer Client		Date
Drawn By Dessiné Par BoxCad: BoxCad		Date 21-Jan-26
Material Matière 12 Ga Cold Rolled A1008 CS Type B (2.5mm)		
Color Couleur Asa-61 Grey	Finish Fini Smooth	
Description 885 MFHD 12" x 18" Mounting Feet		Detail Rev.
Part Number Numéro Pièce 5412DDH606018MF		Rev. 11
SEE BILL OF MATERIAL ON LAST PAGE		0
		18

This drawing is confidential and must not be reproduced or used without the consent of EXM

Ce dessin est confidentiel et ne doit pas être reproduit ou utilisé sans le consentement de EXM

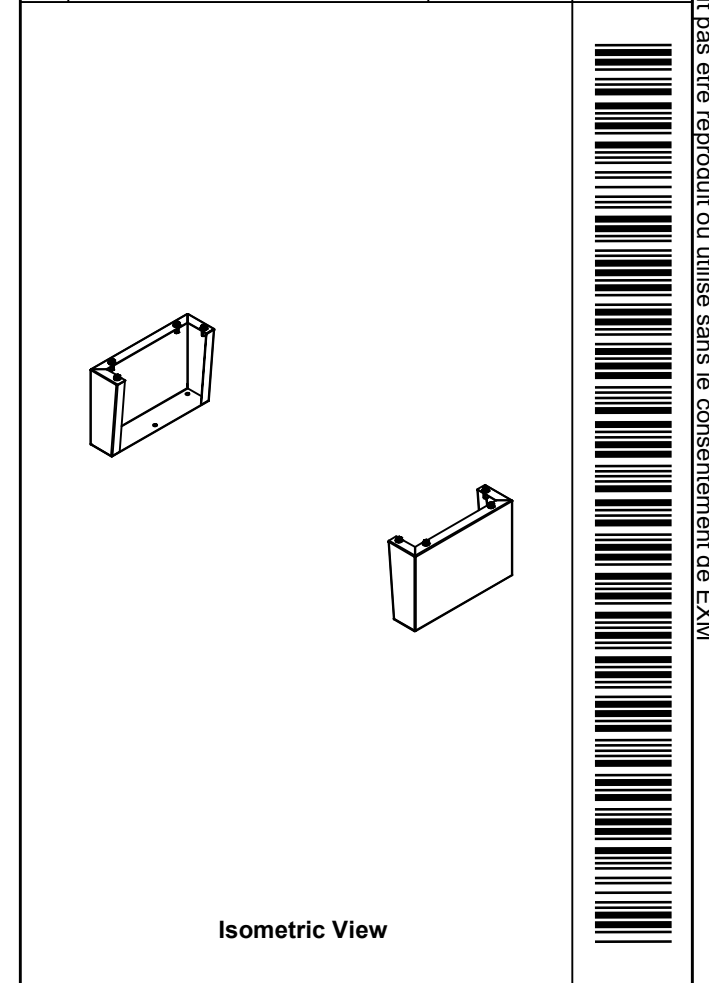
No.	Revisions	Date	By/Par

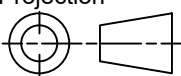

 Tél: (450) 979-4373 Fax: (450) 979-4626 www.exmweb.com		Flatness Aplatissement Max 3.0mm Projection 
Customer Client	Date	
Drawn By Dessiné Par	BoxCad: BoxCad	Date 21-Jan-26
Material Matière	12 Ga Cold Rolled A1008 CS Type B (2.5mm)	
Color Couleur	Asa-61 Grey	Finish Fini Smooth
Description		Detail Rev.
885 MFHD 12" x 18" Mounting Feet		
Part Number Numéro Pièce	Rev.	12
5412DDH606018MF	0	18

Qty	Part Name	Rev	Description
1	STK-P-02400S	0	Powder Paint (Asa-61 Grey / Smooth)
8	RIVET_NUT_M10_FH_CE	0	Rivet Nut M10 (Low Profile Close End)
1	5412DDH606018MFR-P	0	885 MFHD 12" x 18" Right Mounting Feet Part
1	5412DDH606018MFL-P	0	885 MFHD 12" x 18" Left Mounting Feet Part
4	STK-K-11600	2	885 MF Accessory Kit
Parts List			

This drawing is confidential and must not be reproduced or used without the consent of EXM

Ce dessin est confidentiel et ne doit pas être reproduit ou utilisé sans le consentement de EXM

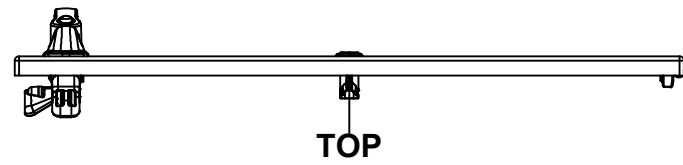

TOP

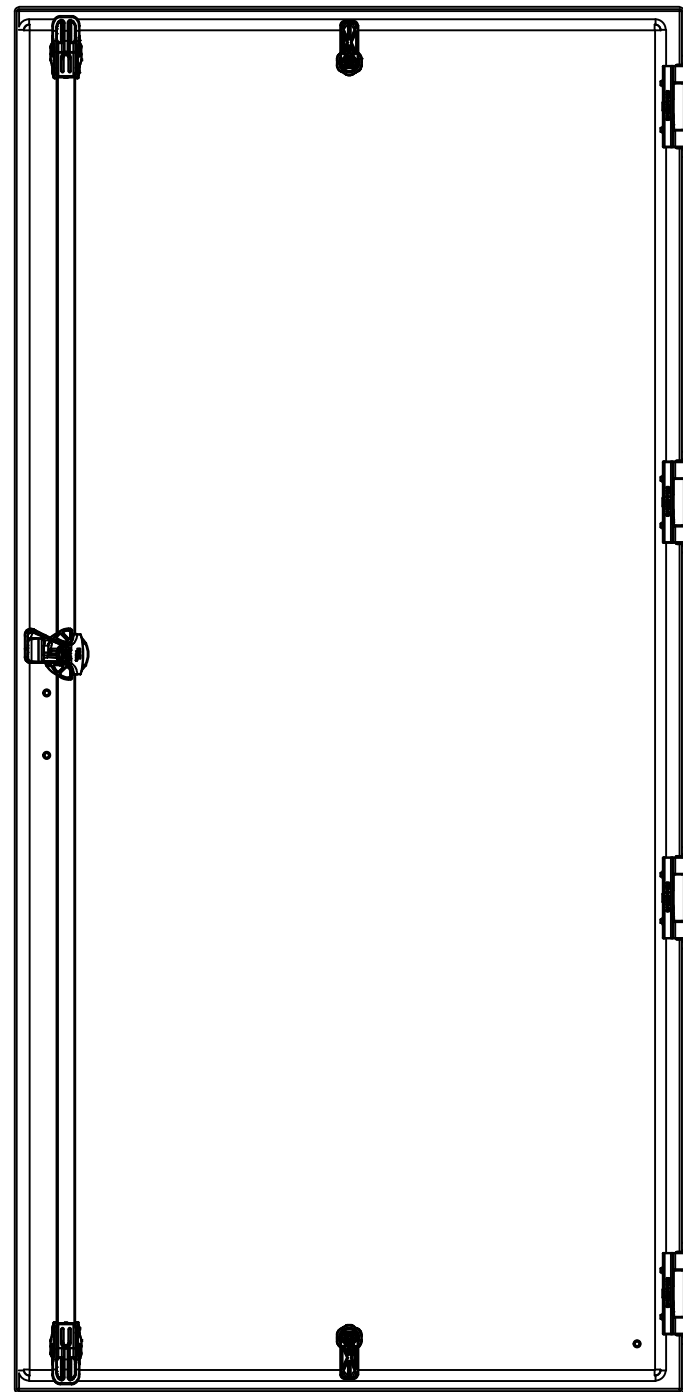

BACK

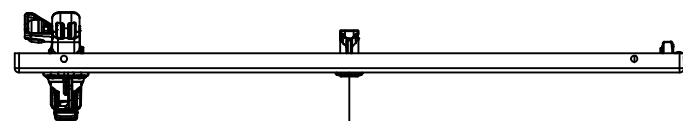

BOTTOM

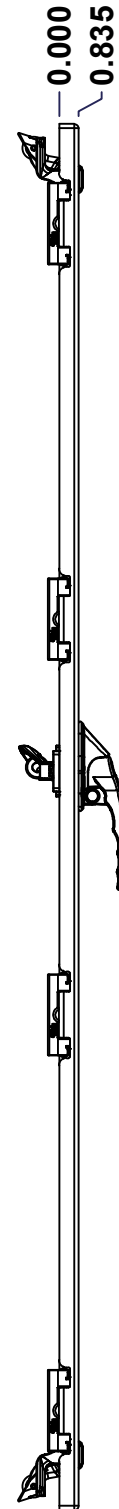

LEFT

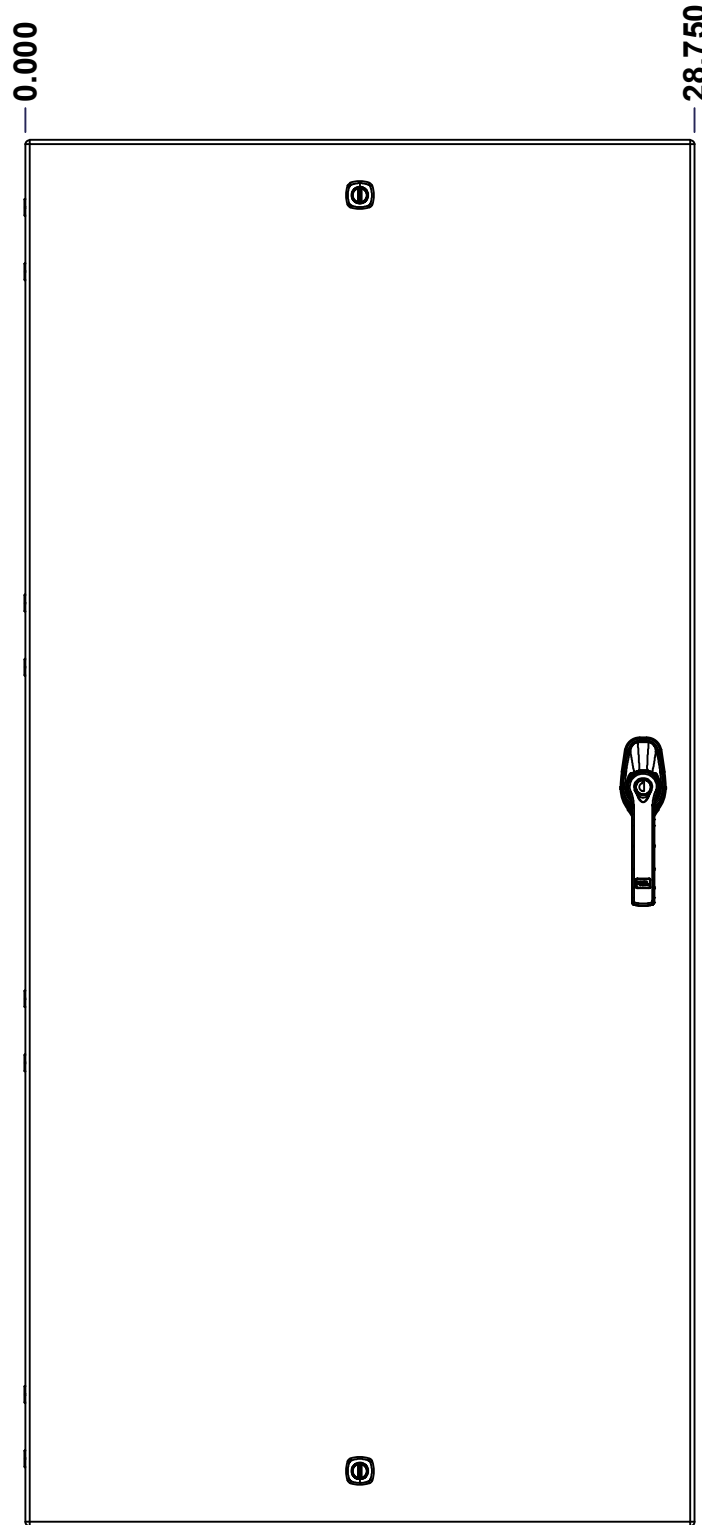

FRONT

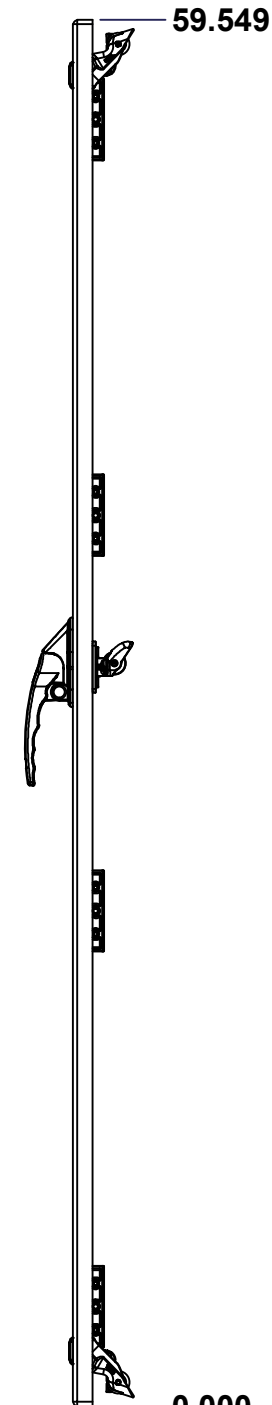

RIGHT

No.	Revisions	Date	By/Par

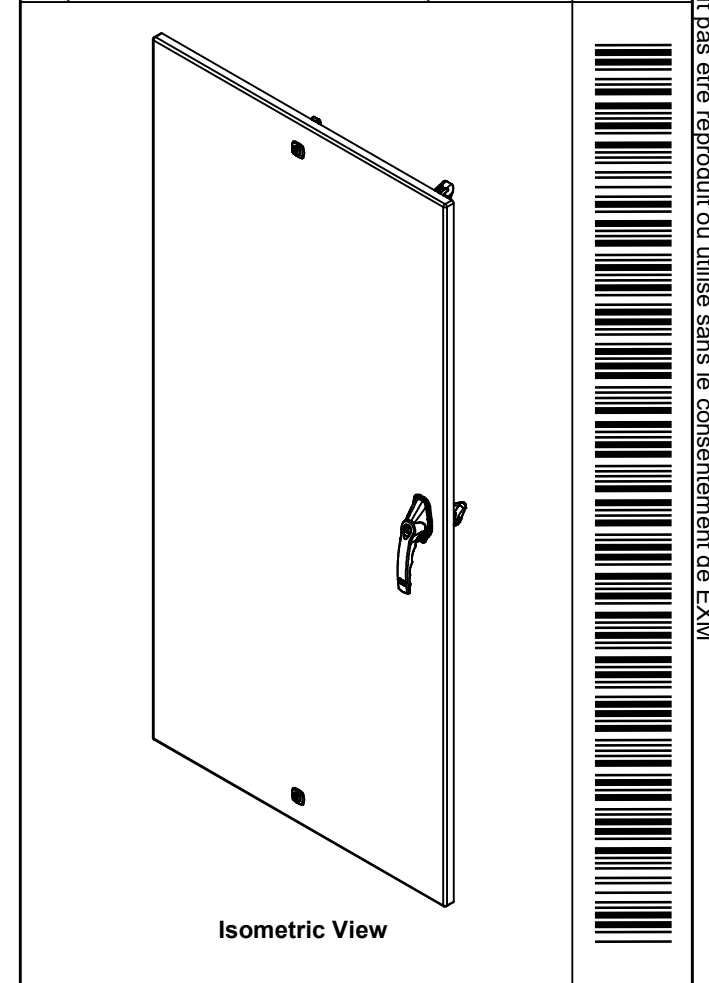

Tél: (450) 979-4373 Fax: (450) 979-4626 www.exmweb.com		Flatness Aplatissement
		Max 3.0mm
Customer Client		Date
Drawn By Dessiné Par BoxCad: BoxCad		Date 21-Jan-26
Material Matière 12 Ga Cold Rolled A1008 CS Type B (2.5mm)		
Color Couleur	Asa-61 Grey	Finish Fini Smooth
Description 5412DDS 60" x 60" Slave Door		Detail Rev.
Part Number Numéro Pièce 5412DDH606018LD		Rev. 13 0

SEE BILL OF MATERIAL ON LAST PAGE

This drawing is confidential and must not be reproduced or used without the consent of EXM

Ce dessin est confidentiel et ne doit pas être reproduit ou utilisé sans le consentement de EXM

STANDARD FEATURES ARE NOT LISTED IN THIS HOLE TABLE

HOLE TABLE - FRONT VIEW (CUSTOM FEATURE ONLY)

CUT-OUT	XDIM	YDIM	DESCRIPTION
1	26.546	6.118	LARGE CBAR GUIDE (Inside)
2	26.546	53.430	LARGE CBAR GUIDE (Inside)
-----	-----	-----	-----
3	26.546	31.743	HANDLE 885 ESL2A-APHK @ 0.0°
4	14.375	57.180	LOCK 889 SCQ4-SL @ 90.0°
5	14.375	2.368	LOCK 889 SCQ4-SL @ 270.0°
6	2.000	2.118	GND STUD M6 x 16mm (Inside)
7	27.372	27.404	STUDS M6 x 18mm (Inside)
8	27.372	30.082	STUDS M6 x 18mm (Inside)

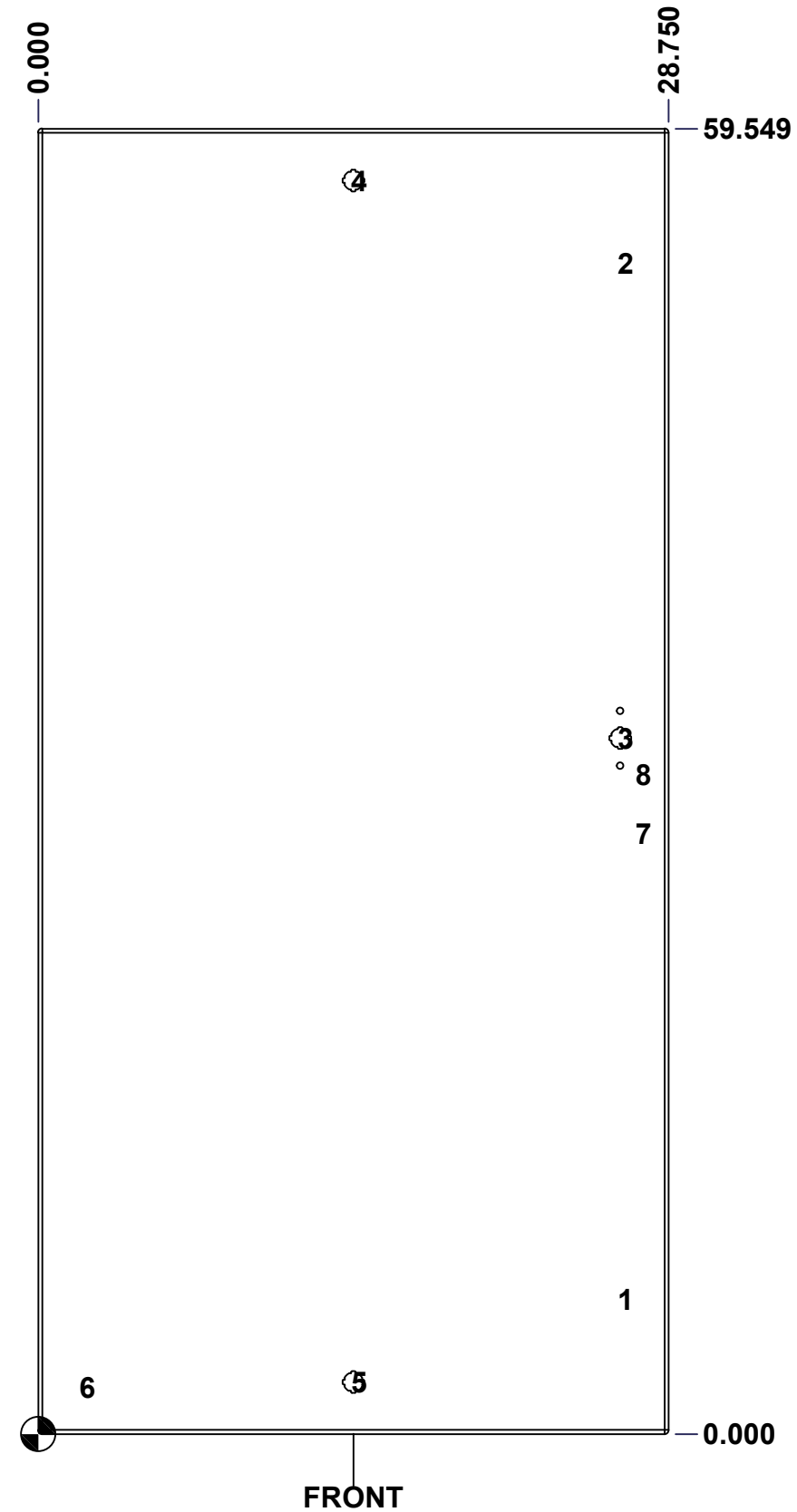

	Description	Status
	5412DDS 60" x 60" Slave Door	(NULL)
	Part Number Numéro Pièce	Rev.
	5412DDH606018LD	0 / 14
		18

This drawing is confidential and must not be reproduced or used without the consent of EXM

Ce dessin est confidentiel et ne doit pas être reproduit ou utilisé sans le consentement de EXM

No.	Revisions	Date	By/Par

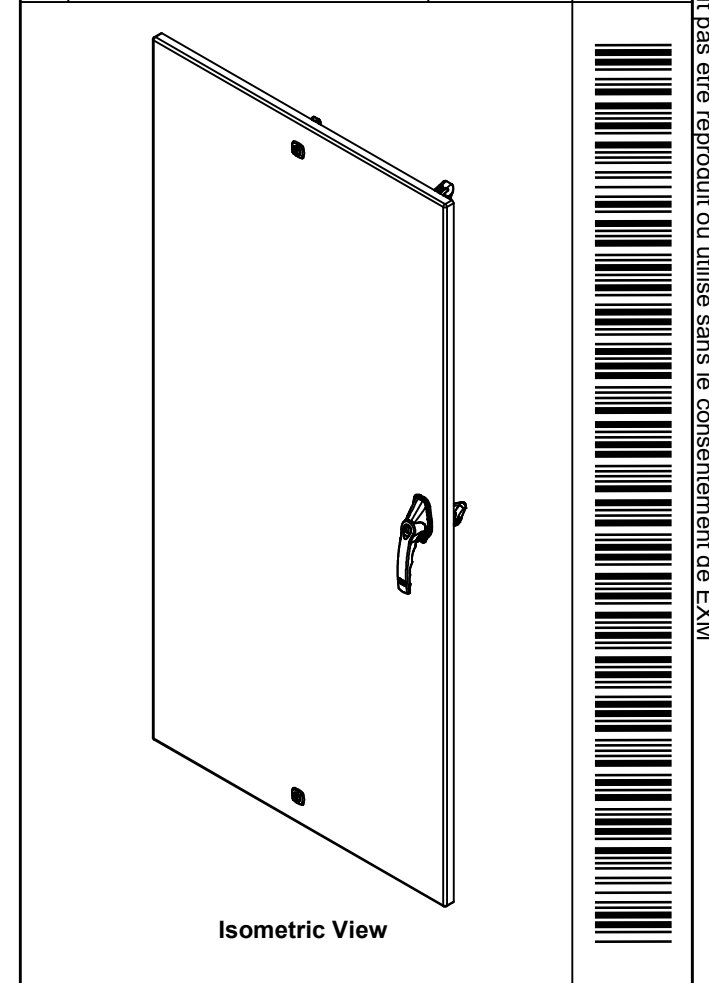

2	STK-Q-16050	1	Stud M6 x 18mm Steel
1	STK-Q-16080	0	Ground Stud M6 x 16mm Steel
2	STK-Q-07220	1	M6 Nylon Insert Lock Nut
1	STK-Q-47541	1	5500 DDS Lower Closing Bar 60"
1	STK-Q-47531	0	5500 DDS Upper Closing Bar 60"
1	STK-A-50538	3	9500 Handle Cam Assembly (Right Side, Grip 36mm)
1	STK-Q-90051	3	5412 ES - Handle Cam Spacer
1	885ESL2A-APHK	7	885 ESL2A-APHK - Zinc Die Cast L-Handle Padlockable Assy
1	STK-P-02400S	0	Powder Paint (Asa-61 Grey / Smooth)
2	STK-Q-16410	0	Guide Stud - Largel (No Paint Cap Required)
1	5412DDH606018DG	0	5412DDS 60" x 60" Door Gasket
1	5412DDH606018LD-P	0	5412DDS 60" x 60" Slave Door Part
2	STK-A-90025	0	9500 - Cabinet Closing Bar End (Large)
4	STK-K-09860	7	Cabinet Hinge with Captive Pins
2	STK-K-12580	0	9412 1/4 Turn Lock

QTY	Part Number	Rev	Description
Parts List			

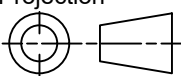
 Tél: (450) 979-4373 Fax: (450) 979-4626 www.exmweb.com	Flatness Aplatissement	Max 3.0mm
	Projection	
Customer Client	Date	
Drawn By Dessiné Par	BoxCad: BoxCad	Date 21-Jan-26
Material Matière	12 Ga Cold Rolled A1008 CS Type B (2.5mm)	
Color Couleur	Asa-61 Grey	Finish Fini Smooth
Description	Detail Rev.	
5412DDS 60" x 60" Slave Door		
Part Number Numéro Pièce	Rev. 0	15 18
5412DDH606018LD		

This drawing is confidential and must not be reproduced or used without the consent of EXM

Ce dessin est confidentiel et ne doit pas être reproduit ou utilisé sans le consentement de EXM

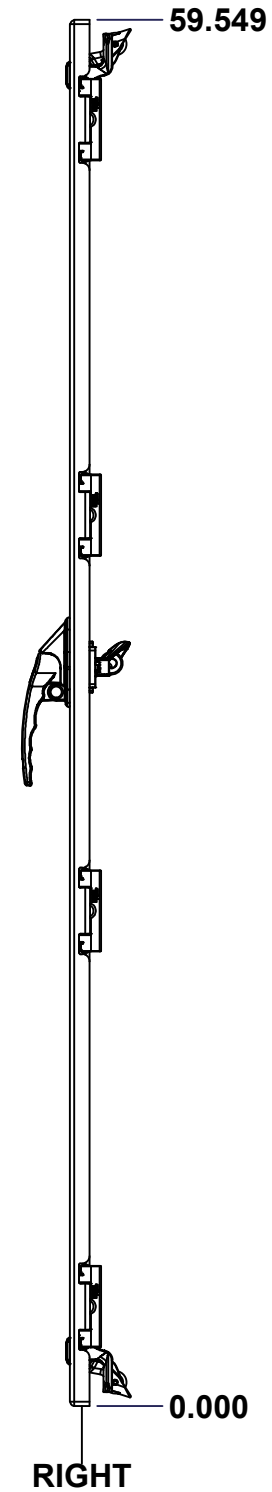
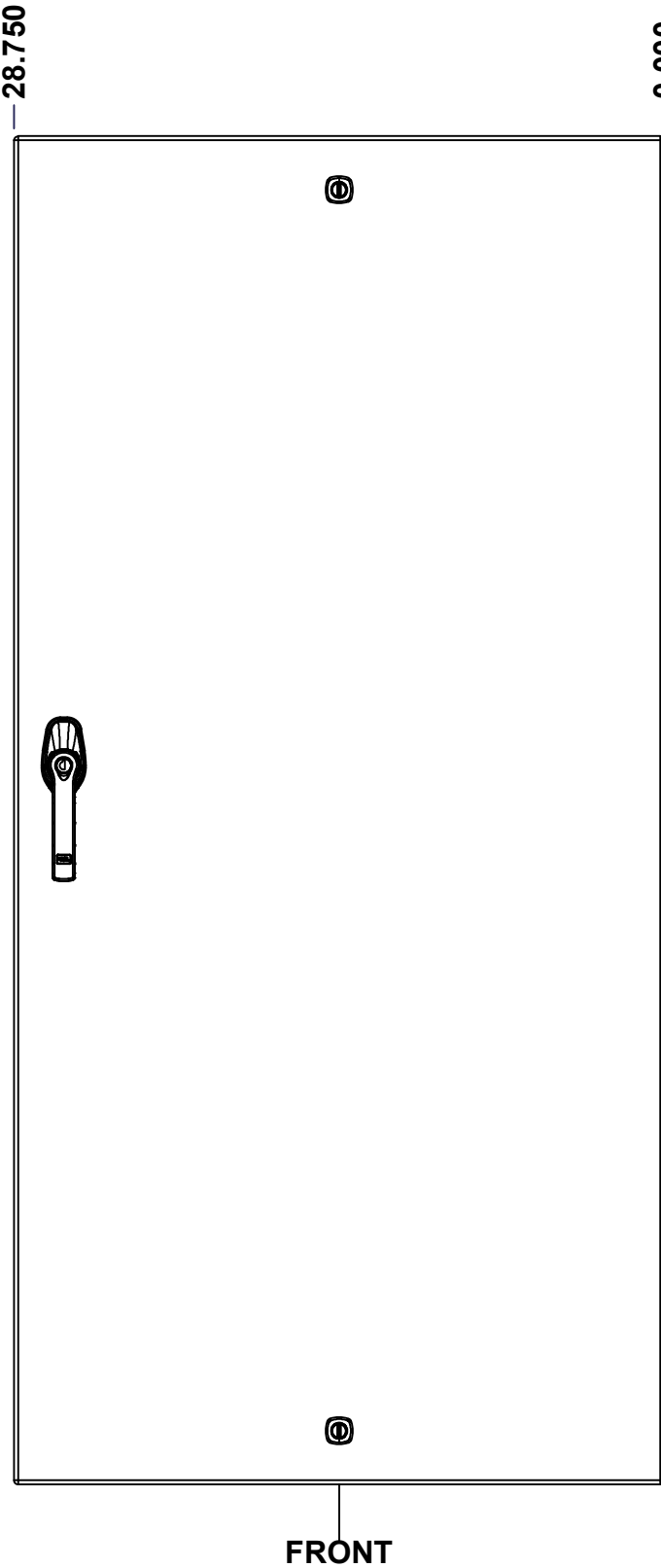
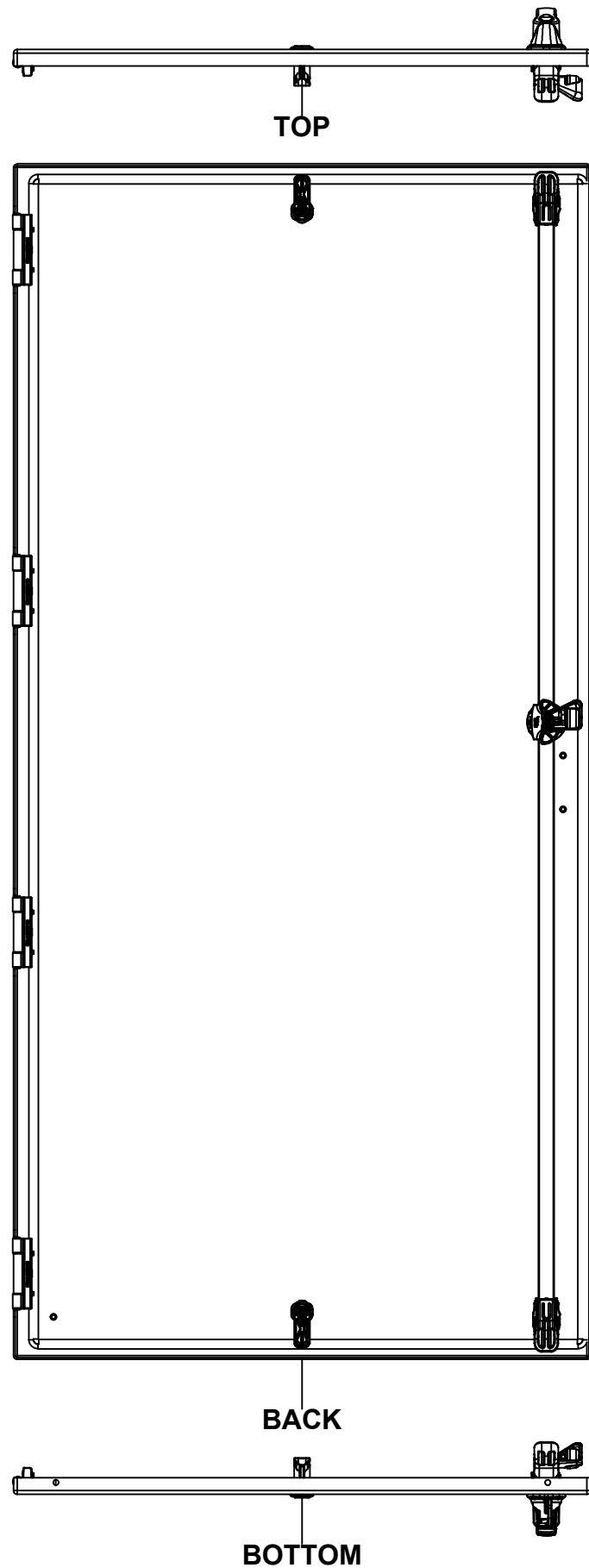

No.	Revisions	Date	By/Par

Isometric View of the door.

Tél: (450) 979-4373 Fax: (450) 979-4626 www.exmweb.com		Flatness Aplatissement Max 3.0mm Projection
Customer Client	Date	
Drawn By Dessiné Par	BoxCad: BoxCad	Date 21-Jan-26
Material Matière	12 Ga Cold Rolled A1008 CS Type B (2.5mm)	
Color Couleur	Asa-61 Grey	Finish Fini Smooth
Description	Detail Rev.	
5412DDS 60" x 60" Master Door		
Part Number Numéro Pièce	Rev. 0	16 18

SEE BILL OF MATERIAL ON LAST PAGE

5412DDH606018FD

This drawing is confidential and must not be reproduced or used without the consent of EXM

Ce dessin est confidentiel et ne doit pas être reproduit ou utilisé sans le consentement de EXM

STANDARD FEATURES ARE NOT LISTED IN THIS HOLE TABLE

HOLE TABLE - FRONT VIEW (CUSTOM FEATURE ONLY)

CUT-OUT	XDIM	YDIM	DESCRIPTION
1	26.546	6.118	LARGE CBAR GUIDE (Inside)
2	26.546	53.430	LARGE CBAR GUIDE (Inside)
-----	-----	-----	-----
3	26.546	31.743	HANDLE 885 ESL2A-APHK
4	14.375	57.180	LOCK 889 SCQ4-SL @ 90.0°
5	14.375	2.368	LOCK 889 SCQ4-SL @ 270.0°
6	2.000	2.118	GND STUD M6 x 16mm (Inside)
7	27.372	27.404	STUDS M6 x 18mm (Inside)
8	27.372	30.082	STUDS M6 x 18mm (Inside)

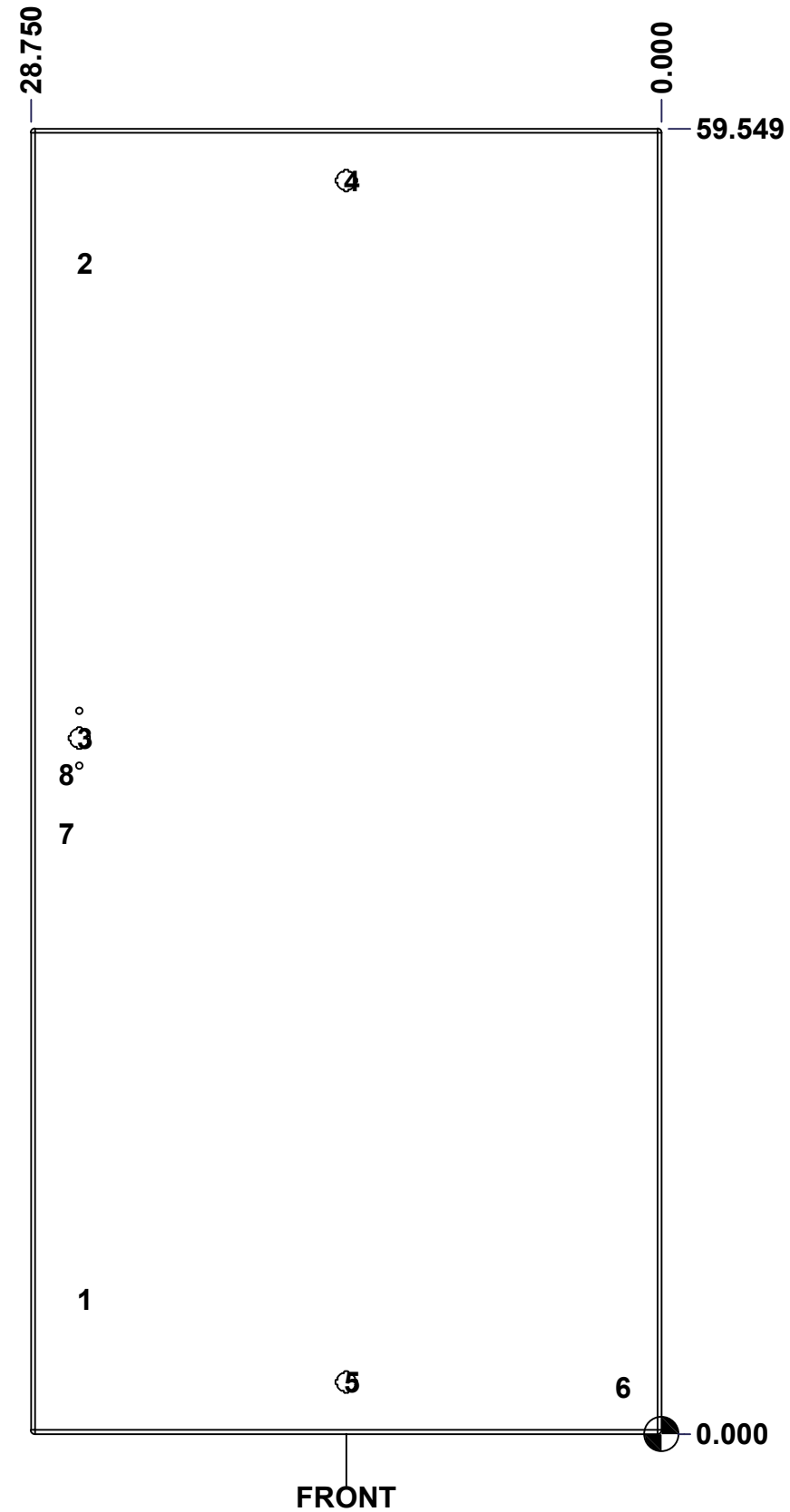

	Description	Status
	5412DDS 60" x 60" Master Door	(NULL)
Part Number Numéro Pièce 5412DDH606018FD	Rev.	17
	0	18

This drawing is confidential and must not be reproduced or used without the consent of EXM

Ce dessin est confidentiel et ne doit pas être reproduit ou utilisé sans le consentement de EXM

No.	Revisions	Date	By/Par

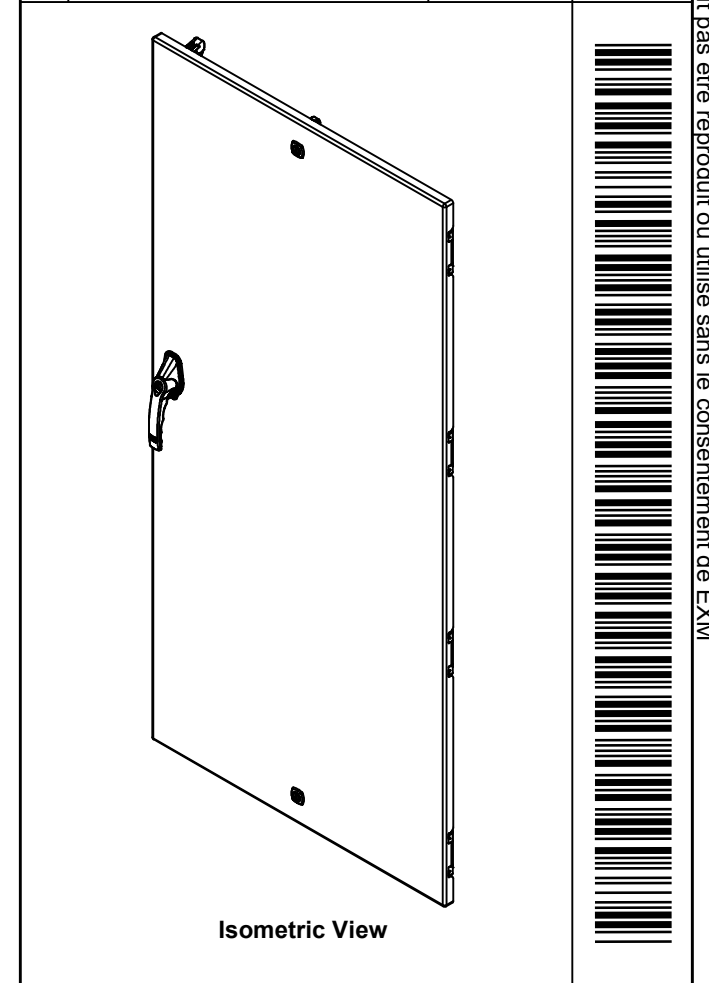

2	STK-Q-16050	1	Stud M6 x 18mm Steel
1	STK-Q-16080	0	Ground Stud M6 x 16mm Steel
2	STK-Q-07220	1	M6 Nylon Insert Lock Nut
1	STK-Q-47541	1	5500 DDS Lower Closing Bar 60"
1	STK-Q-47531	0	5500 DDS Upper Closing Bar 60"
1	STK-A-50537	3	9500 Handle Cam Assembly (Left Side, Grip 36mm)
1	STK-Q-90051	3	5412 ES - Handle Cam Spacer
1	885ESL2A-APHK	7	885 ESL2A-APHK - Zinc Die Cast L-Handle Padlockable Assy
1	STK-P-02400S	0	Powder Paint (Asa-61 Grey / Smooth)
2	STK-Q-16410	0	Guide Stud - Largel (No Paint Cap Required)
1	5412DDH606018DG	0	5412DDS 60" x 60" Door Gasket
1	5412DDH606018FD-P	0	5412DDS 60" x 60" Master Door Part
2	STK-A-90025	0	9500 - Cabinet Closing Bar End (Large)
4	STK-K-09860	7	Cabinet Hinge with Captive Pins
2	STK-K-12580	0	9412 1/4 Turn Lock

QTY	Part Number	Rev	Description
Parts List			

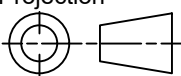
 Tél: (450) 979-4373 Fax: (450) 979-4626 www.exmweb.com	Flatness Aplatissement	Max 3.0mm
	Projection	
Customer Client	Date	
Drawn By Dessiné Par	BoxCad: BoxCad	Date 21-Jan-26
Material Matière	12 Ga Cold Rolled A1008 CS Type B (2.5mm)	
Color Couleur	Asa-61 Grey	Finish Fini Smooth
Description	Detail Rev.	
5412DDS 60" x 60" Master Door		
Part Number Numéro Pièce	Rev.	18
5412DDH606018FD	0	18

This drawing is confidential and must not be reproduced or used without the consent of EXM

Ce dessin est confidentiel et ne doit pas être reproduit ou utilisé sans le consentement de EXM

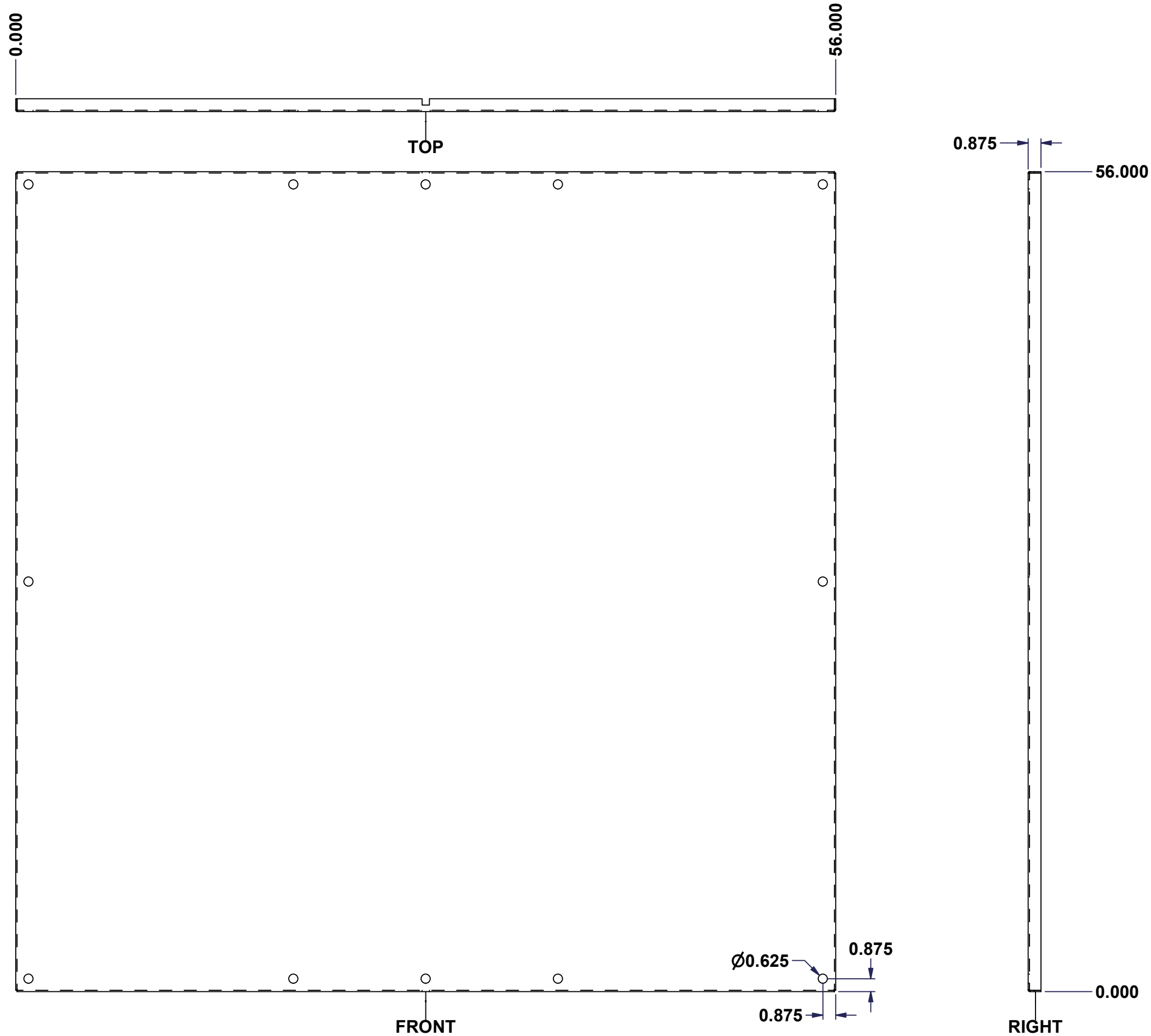

SEE BILL OF MATERIAL ON LAST PAGE

No.	Revisions	Date	By/Par

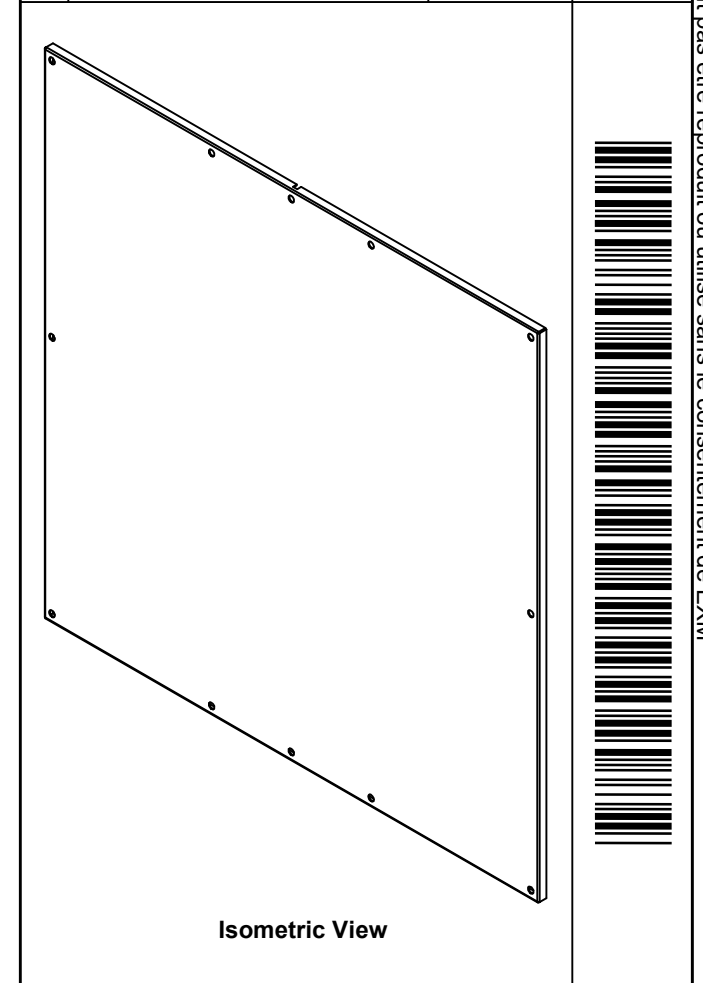

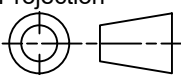

 Tél: (450) 979-4373 Fax: (450) 979-4626 www.exmweb.com		Flatness Aplatissement Max 3.0mm
Customer Client		Projection 
Drawn By / Dessiné Par: BoxCad		Date: 04/11/2009
Material / Matière: 12 Ga Galvanized (2.5mm)		
Color / Couleur: Unpainted	Finish / Fini: Unpainted	
Description: 885 SP6060G Inner Panel		Detail Rev.
Part Number / Numéro Pièce: 885SP6060G		Rev. 1 0

This drawing is confidential and must not be reproduced or used without the consent of EXM

Ce dessin est confidentiel et ne doit pas être reproduit ou utilisé sans le consentement de EXM

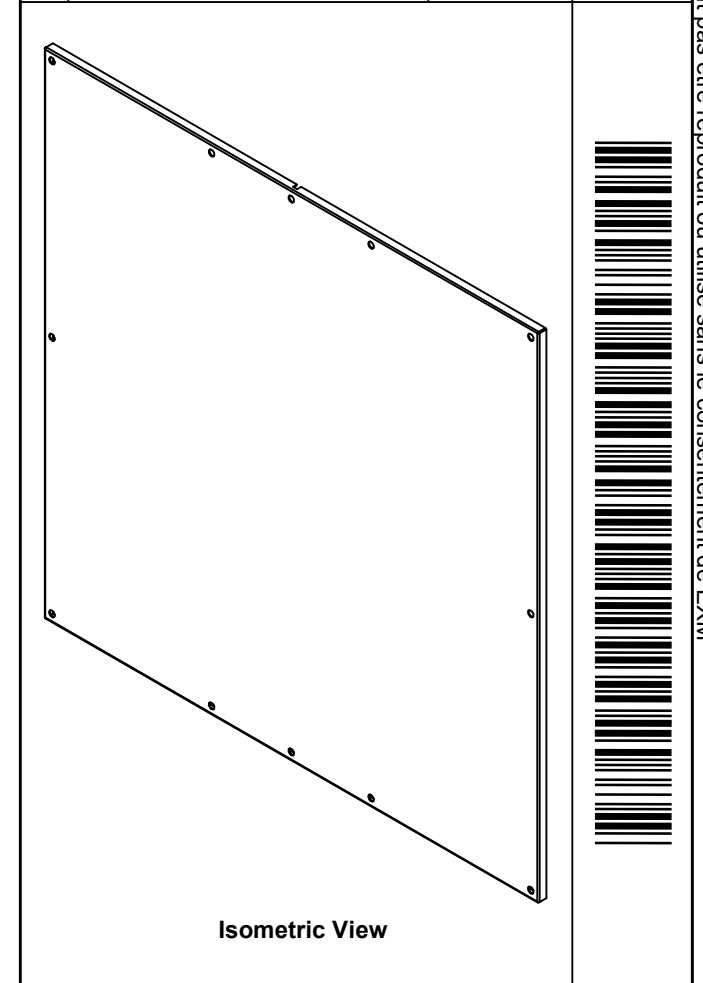
No.	Revisions	Date	By/Par



 Tél: (450) 979-4373 Fax: (450) 979-4626 www.exmweb.com		Flatness Aplatissement Max 3.0mm
Customer Client		Date
Drawn By / Dessiné Par: BoxCad		Date: 04/11/2009
Material / Matière: 12 Ga Galvanized (2.5mm)		
Color / Couleur: Unpainted	Finish / Fini: Unpainted	
Description: 885 SP6060G Inner Panel		Detail Rev.
Part Number / Numéro Pièce: 885SP6060G		Rev. 0 / 2

Qty	Part Number	Rev	Description
1	885SP6060G-P	0	885 SP6060G Inner Panel Part
Parts List			