

This drawing is confidential and must not be reproduced or used without the consent of EXM

Ce dessin est confidentiel et ne doit pas être reproduit ou utilisé sans le consentement de EXM

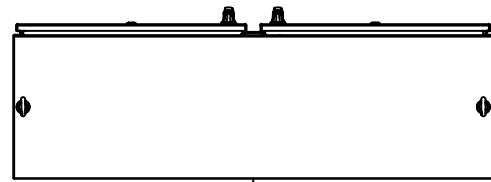

TOP

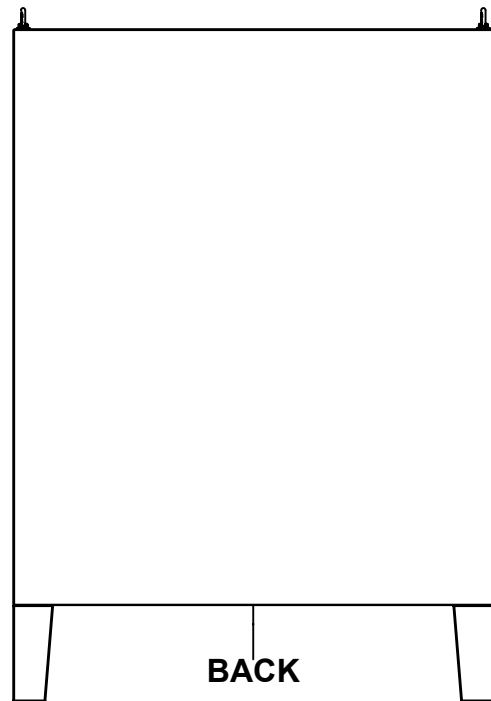

BACK

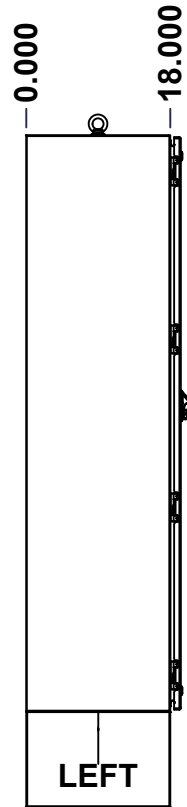

LEFT

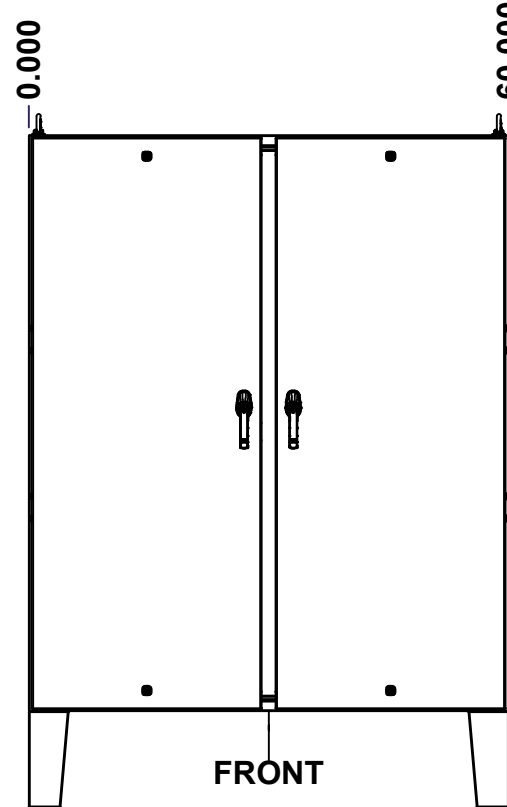

FRONT

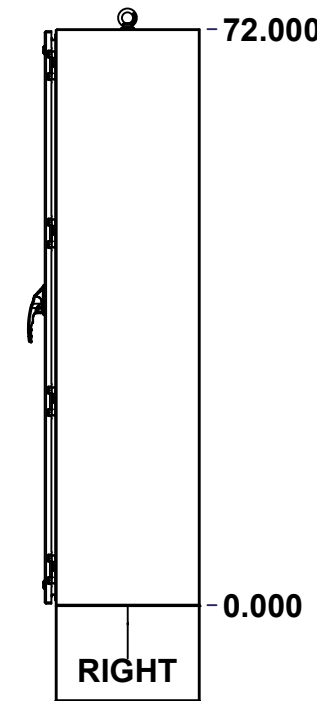

RIGHT

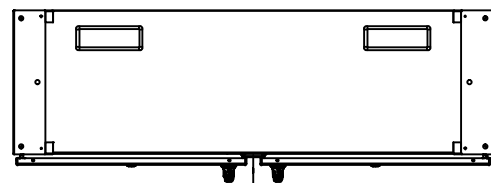

BOTTOM

APPROVED FOR PRODUCTION
APPROUVÉ POUR PRODUCTION
 SIGNATURE: _____
 NAME / NOM: _____
 DATE: _____
 Please visit: www.boxcadexm.com

No.	Revisions	Date	By/Par

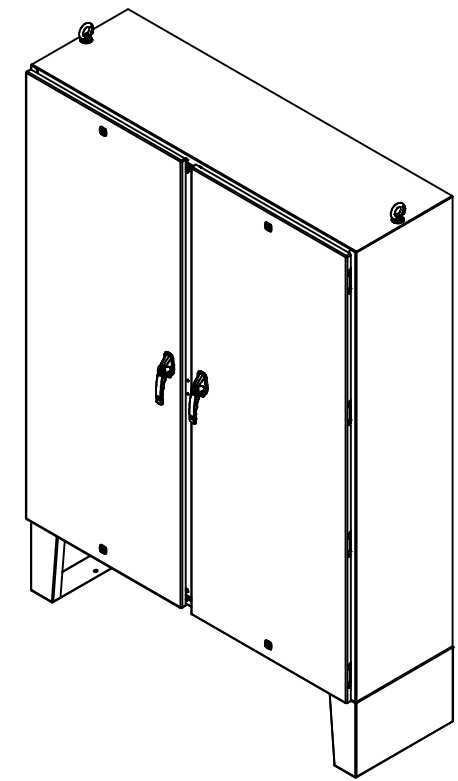

Isometric View

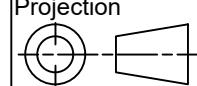

 Tél: (450) 979-4373 Fax: (450) 979-4626 www.exmweb.com		Flatness Aplatissement Max 3.0mm Projection 
Customer Client	Date	
Drawn By Dessiné Par	BoxCad: slam	Date 12-Aug-25
Material Matière	12 Ga Cold Rolled A1008 CS Type B (2.5mm)	
Color Couleur	Asa-61 Grey	Finish Fini Rough Textured
Description	Detail Rev.	
5412DDS 72" x 60" x 18" Assembly		
Part Number Numéro Pièce	Rev.	1
5412DDH726018	0	18

SEE BILL OF MATERIAL ON LAST PAGE

This drawing is confidential and must not be reproduced or used without the consent of EXM

Ce dessin est confidentiel et ne doit pas être reproduit ou utilisé sans le consentement de EXM

NOTE

ITEM	DESCRIPTION
1	NEMA 4, 12 Enclosure (IP66)
2	C/W Standard ground studs on box and cover
3	W/O Standard door stiffener
4	C/W Standard inner panel (Sold separately)
5	C/W Standard inner panel mounting studs
6	C/W Eyebolts sold separately (Installed by EXM)
7	C/W Special handle sold separately (Kit)
8	C/W Mounting feet sold separately (Installed)
9	C/W Struts sold separately (Welded by EXM)
10	C/W Interlock Kit (Installed by EXM)

**APPROVED FOR PRODUCTION
APPROUVÉ POUR PRODUCTION**

SIGNATURE: _____
NAME / NOM: _____
DATE: _____

Please visit: www.boxcadexm.com

No.	Revisions	Date	By/Par

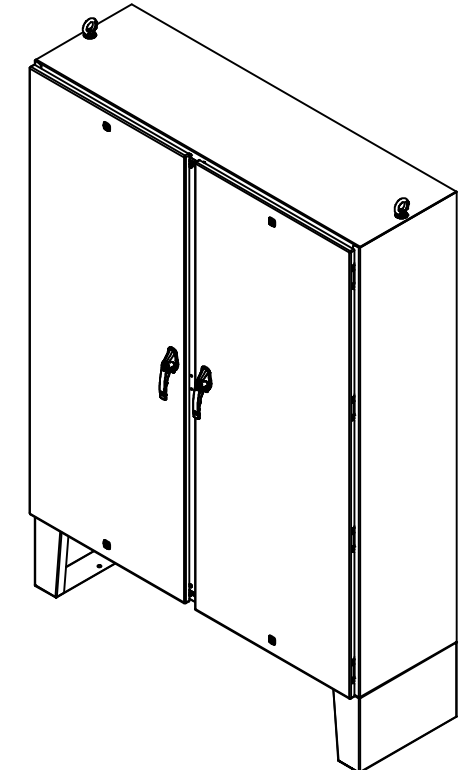

Isometric View



Tél: (450) 979-4373
Fax: (450) 979-4626
www.exmweb.com

Flatness
Aplatissement
Max 3.0mm
Projection

Customer
Client
Date

Drawn By
Dessiné Par BoxCad: slam
Date 12-Aug-25

Material
Matière 12 Ga Cold Rolled A1008 CS Type B (2.5mm)

Color
Couleur Asa-61 Grey
Finish
Fini Rough Textured

Description
5412DDS 72" x 60" x 18" Assembly
Detail Rev.

Part Number
Numéro Pièce
5412DDH726018
Rev. 0 2 18

1	5412DDH726018MF	0	885 MFHD 12" x 18" Mounting Feet
8	STK-Q-07320	0	Flange Lock Nut M10
1	885SP7260G	0	885 SP7260G Inner Panel
1	880INTI	4	880 INTI - Interlock Post Kit
1	880EB14	2	Eye Bolt M14 (Pack of 2)
8	STK-Q-07620	0	M10 Plastic Spacer 0.875"
1	5412DDH726018FD	0	5412DDS 72" x 60" Master Door
1	5412DDH726018LD	0	5412DDS 72" x 60" Slave Door
1	5412DDH726018B	0	5412DDS 72" x 60" x 18" Body
2	5412DDH726018GP	0	5412DDS Gland Plate
8	STK-Q-04050-10	8	M6 x 10mm Hexagon Socket Head Machine Screw with Nyseal
Qty	Part Number	Rev	Description
Parts List			

PACKING

ITEM	QTY	DESCRIPTION
Cardboard sleeve	2	Top and Bottom
Cardboard strip	2	Between back of enclosure and inner panel
Plastic bag	1	To protect cover surface and inside gasket
Cardboard corner	4	To reinforced for the plastic strap tightening
Plastic strap - Black	2	To Squeeze 2 cardboard sleeve together
Packaging label	3	White label with PN
Plastic strap- Green	2	To secure the enclosure to the wood pallet
Wood Pallet	1	2" deeper and 3" larger than enclosure size

This drawing is confidential and must not be reproduced or used without the consent of EXM

Ce dessin est confidentiel et ne doit pas être reproduit ou utilisé sans le consentement de EXM

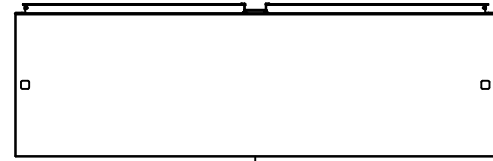

TOP

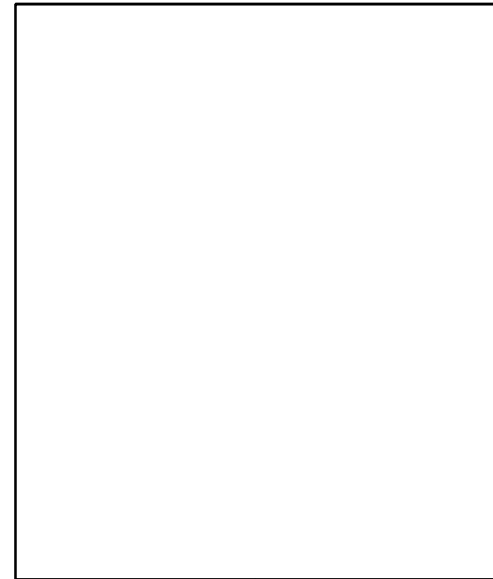

BACK



BOTTOM

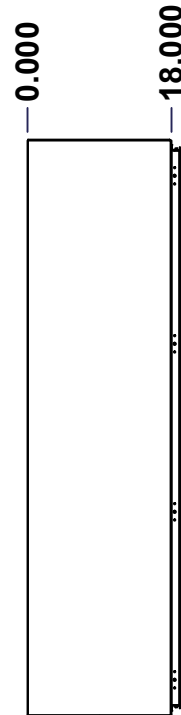

LEFT

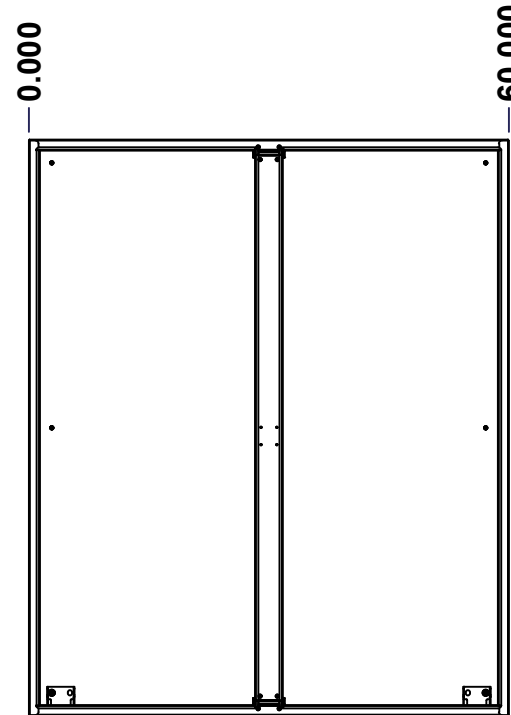

FRONT

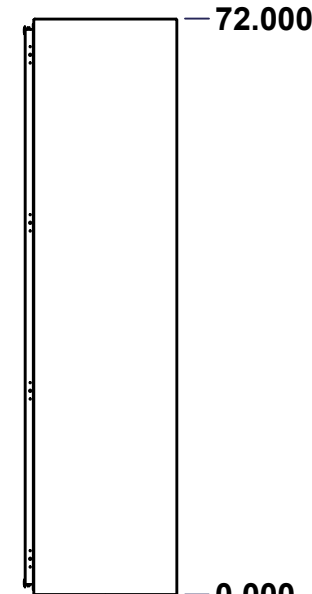

RIGHT

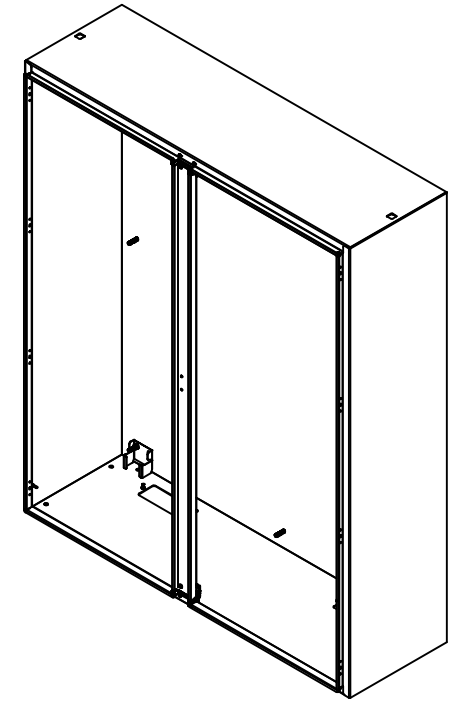

Isometric View



APPROVED FOR PRODUCTION
APPROUVÉ POUR PRODUCTION
 SIGNATURE: _____
 NAME / NOM: _____
 DATE: _____
 Please visit: www.boxcadexm.com

No.	Revisions	Date	By/Par

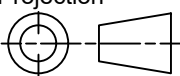
 Tél: (450) 979-4373 Fax: (450) 979-4626 www.exmweb.com		Flatness Aplatissement Max 3.0mm Projection 
Customer Client	Date	
Drawn By Dessiné Par	BoxCad: slam	Date 12-Aug-25
Material Matière	12 Ga Cold Rolled A1008 CS Type B (2.5mm)	
Color Couleur	Asa-61 Grey	Finish Fini Rough Textured
Description	Detail Rev.	
5412DDS 72" x 60" x 18" Body		
Part Number Numéro Pièce	Rev.	3
5412DDH726018B	0	18

SEE BILL OF MATERIAL ON LAST PAGE

This drawing is confidential and must not be reproduced or used without the consent of EXM

Ce dessin est confidentiel et ne doit pas être reproduit ou utilisé sans le consentement de EXM

STANDARD FEATURES ARE NOT LISTED IN THIS HOLE TABLE

HOLE TABLE - TOP VIEW (CUSTOM FEATURE ONLY)

CUT-OUT	XDIM	YDIM	DESCRIPTION
1	44.911	13.911	Struts CR400 21.500" (Inside)
2	14.911	13.911	Struts CR400 21.500" (Inside)
3	44.911	14.840	STUDS M6 x 10mm (Inside)
4	55.777	13.911	STUDS M6 x 10mm (Inside)
5	14.911	14.840	STUDS M6 x 10mm (Inside)
6	25.777	13.911	STUDS M6 x 10mm (Inside)

APPROVED FOR PRODUCTION
APPROUVÉ POUR PRODUCTION

SIGNATURE: _____
 NAME / NOM: _____
 DATE: _____

Please visit: www.boxcadexm.com

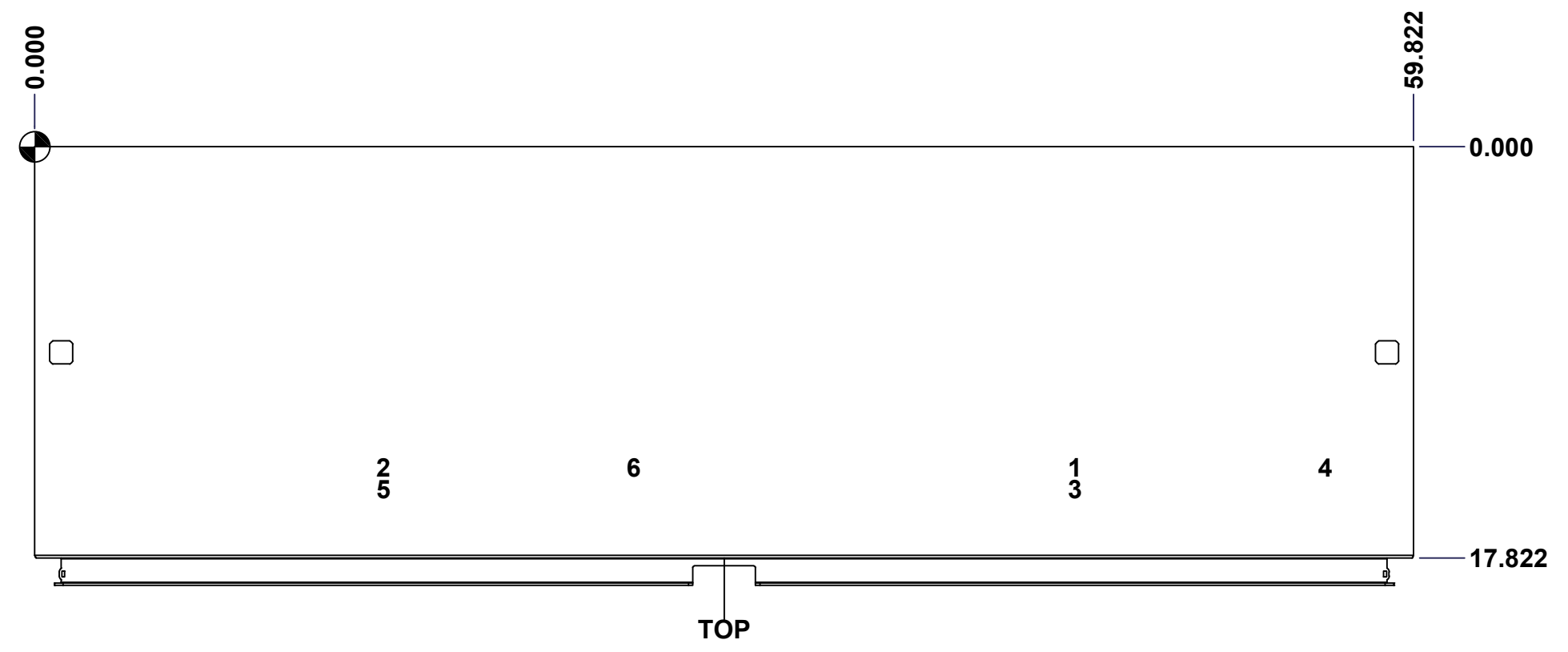

	Description	Status	
	5412DDS 72" x 60" x 18" Body	(NULL)	
	Part Number Numéro Pièce	Rev.	
	5412DDH726018B	0	4 18

This drawing is confidential and must not be reproduced or used without the consent of EXM

Ce dessin est confidentiel et ne doit pas être reproduit ou utilisé sans le consentement de EXM

STANDARD FEATURES ARE NOT LISTED IN THIS HOLE TABLE

HOLE TABLE - RIGHT VIEW (CUSTOM FEATURE ONLY)

CUT-OUT	XDIM	YDIM	DESCRIPTION
1	16.411	3.286	GND STUD M6 x 16mm (Inside)

APPROVED FOR PRODUCTION
APPROUVÉ POUR PRODUCTION

SIGNATURE: _____
 NAME / NOM: _____
 DATE: _____

Please visit: www.boxcadexm.com

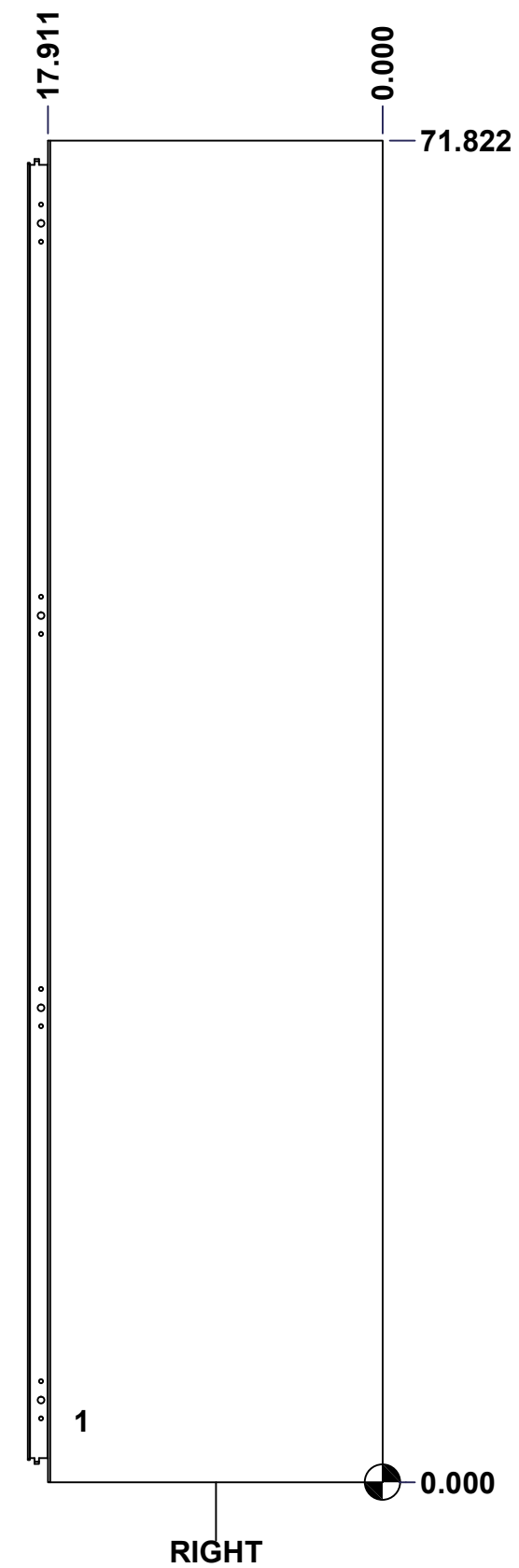

	Description		Status
	5412DDS 72" x 60" x 18" Body		(NULL)
Part Number Numéro Pièce		Rev.	5
5412DDH726018B		0	18

This drawing is confidential and must not be reproduced or used without the consent of EXM

Ce dessin est confidentiel et ne doit pas être reproduit ou utilisé sans le consentement de EXM

STANDARD FEATURES ARE NOT LISTED IN THIS HOLE TABLE

HOLE TABLE - BOTTOM VIEW (CUSTOM FEATURE ONLY)

CUT-OUT	XDIM	YDIM	DESCRIPTION
1	7.286	3.411	GP STUD M6 x 16mm (Inside)
2	16.536	3.411	GP STUD M6 x 16mm (Inside)
3	43.286	3.411	GP STUD M6 x 16mm (Inside)
4	52.536	3.411	GP STUD M6 x 16mm (Inside)

5	3.911	0.911	RND Ø0.500
6	0.911	2.911	RND Ø0.500
7	0.911	14.911	RND Ø0.500
8	3.911	16.911	RND Ø0.500
9	55.911	0.911	RND Ø0.500
10	58.911	2.911	RND Ø0.500
11	58.911	14.911	RND Ø0.500
12	55.911	16.911	RND Ø0.500

APPROVED FOR PRODUCTION
APPROUVÉ POUR PRODUCTION

SIGNATURE: _____
 NAME / NOM: _____
 DATE: _____

Please visit: www.boxcadexm.com

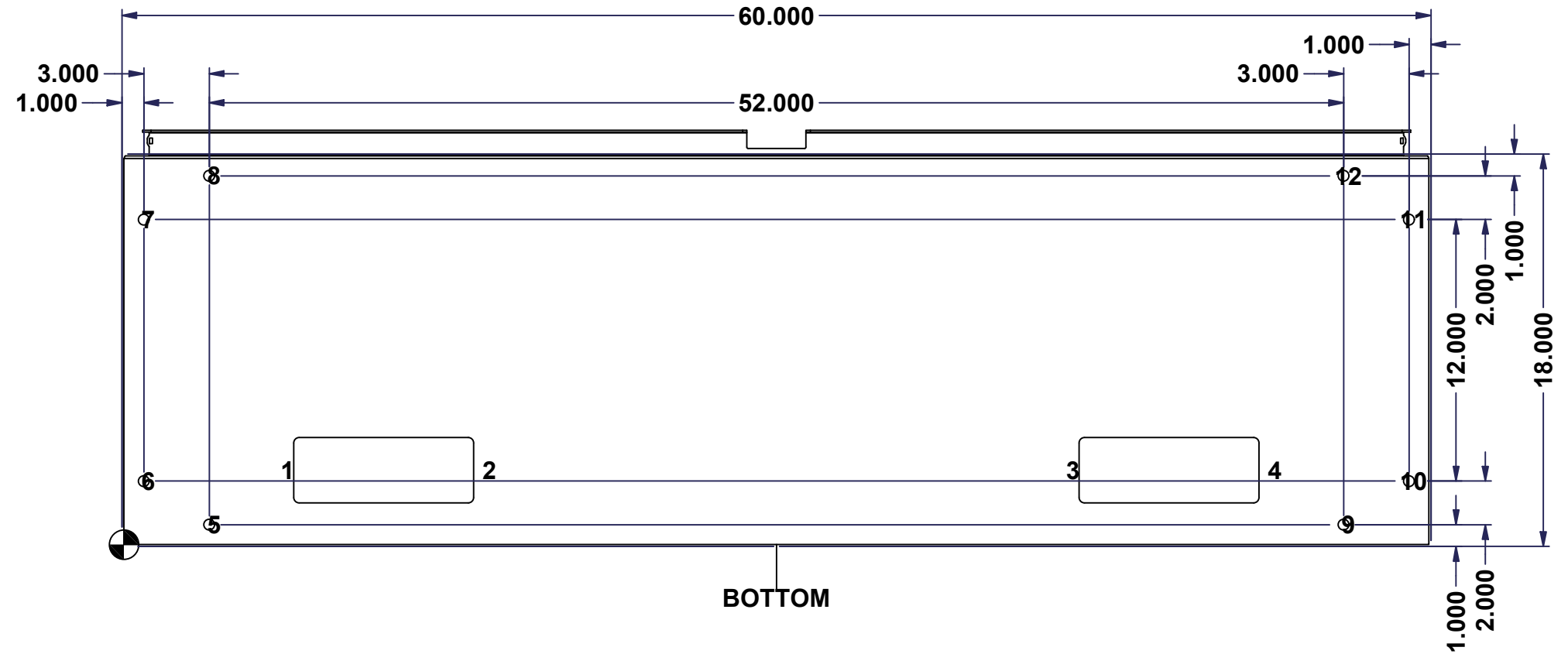

	Description	Status	
	5412DDS 72" x 60" x 18" Body	(NULL)	
	Part Number Numéro Pièce	Rev.	6
	5412DDH726018B	0	18

This drawing is confidential and must not be reproduced or used without the consent of EXM

Ce dessin est confidentiel et ne doit pas être reproduit ou utilisé sans le consentement de EXM

STANDARD FEATURES ARE NOT LISTED IN THIS HOLE TABLE

HOLE TABLE - LEFT VIEW (CUSTOM FEATURE ONLY)

CUT-OUT	XDIM	YDIM	DESCRIPTION
1	16.411	3.286	GND STUD M6 x 16mm (Inside)

APPROVED FOR PRODUCTION
APPROUVÉ POUR PRODUCTION
 SIGNATURE: _____
 NAME / NOM: _____
 DATE: _____
 Please visit: www.boxcadexm.com

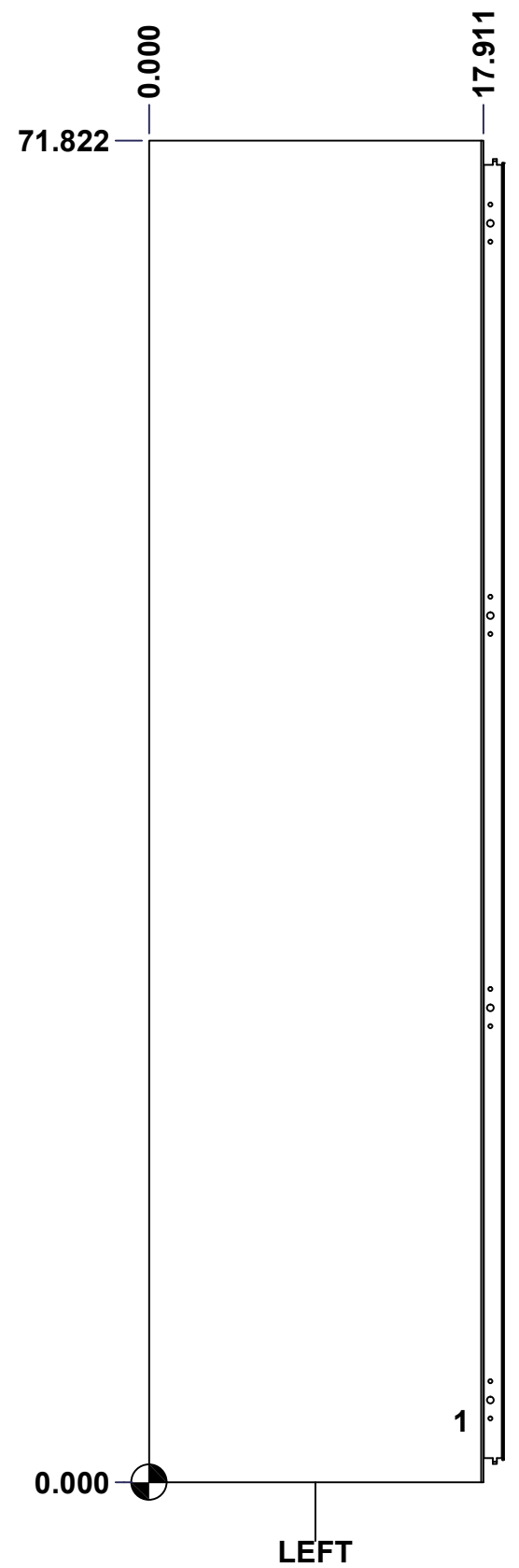

	Description	Status	
	5412DDS 72" x 60" x 18" Body	(NULL)	
	Part Number Numéro Pièce	Rev.	7
	5412DDH726018B	0	18

This drawing is confidential and must not be reproduced or used without the consent of EXM

Ce dessin est confidentiel et ne doit pas être reproduit ou utilisé sans le consentement de EXM

STANDARD FEATURES ARE NOT LISTED IN THIS HOLE TABLE

HOLE TABLE - BACK VIEW (CUSTOM FEATURE ONLY)

CUT-OUT	XDIM	YDIM	DESCRIPTION
1	2.786	2.786	IP STUD M10 x 40mm (Inside)
2	57.036	2.786	IP STUD M10 x 40mm (Inside)
3	2.786	35.911	IP STUD M10 x 40mm (Inside)
4	57.036	35.911	IP STUD M10 x 40mm (Inside)
5	2.786	69.036	IP STUD M10 x 40mm (Inside)
6	57.036	69.036	IP STUD M10 x 40mm (Inside)
7	29.911	2.786	IP STUD M10 x 40mm (Inside)
8	29.911	69.036	IP STUD M10 x 40mm (Inside)

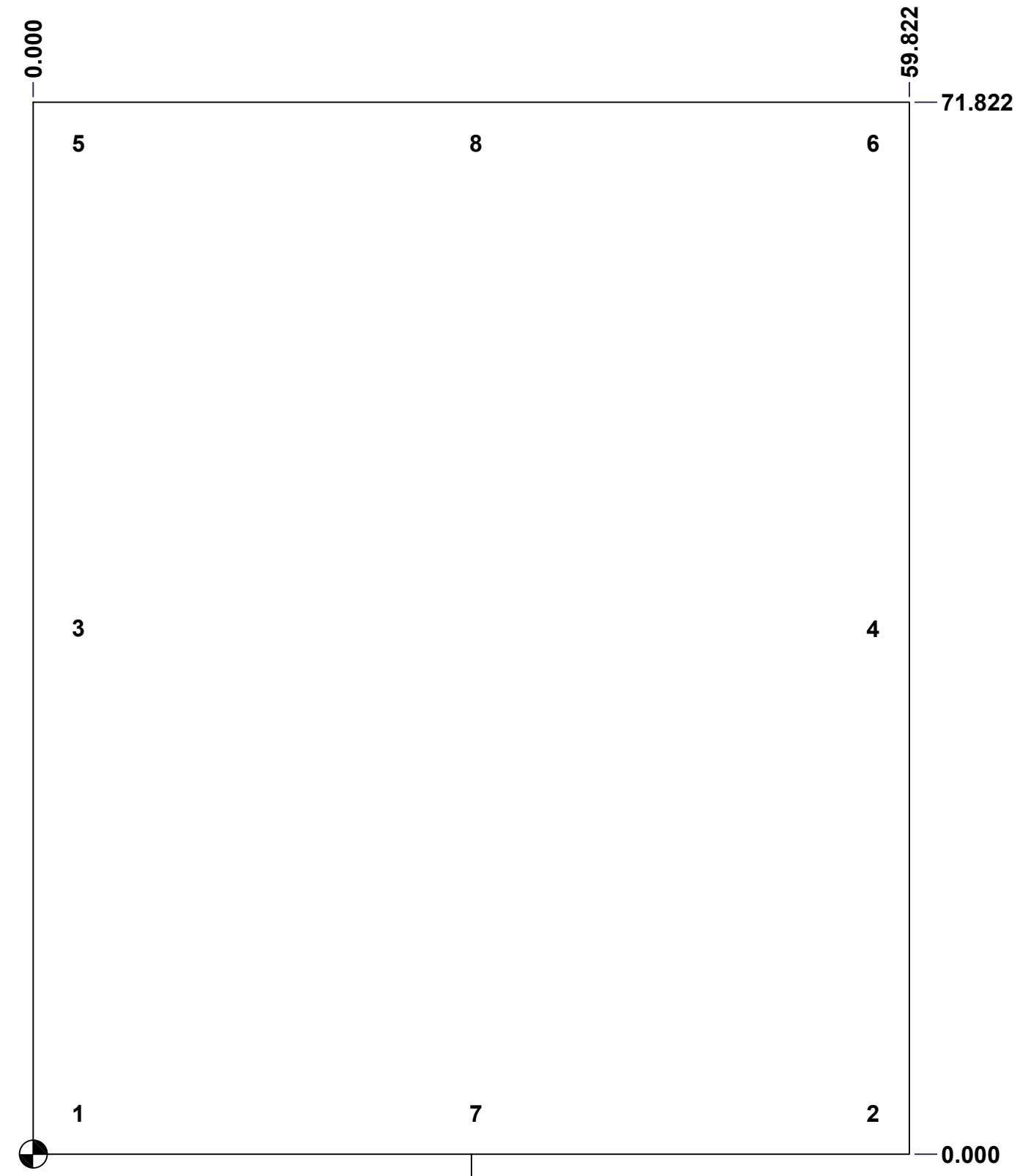

BACK

APPROVED FOR PRODUCTION
APPROUVÉ POUR PRODUCTION

SIGNATURE: _____
 NAME / NOM: _____
 DATE: _____

Please visit: www.boxcadexm.com

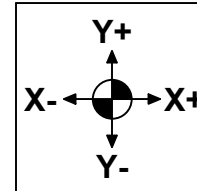

Description		Status	
5412DDS 72" x 60" x 18" Body		(NULL)	
Part Number Numéro Pièce		Rev.	8
5412DDH726018B		0	18

This drawing is confidential and must not be reproduced or used without the consent of EXM

Ce dessin est confidentiel et ne doit pas être reproduit ou utilisé sans le consentement de EXM

STANDARD FEATURES ARE NOT LISTED IN THIS HOLE TABLE

HOLE TABLE - CENTER VIEW (CUSTOM FEATURE ONLY)

CUT-OUT	XDIM	YDIM	DESCRIPTION
1	0.748	32.179	PEM FH-M6-15ZI (Inside)
2	0.748	34.305	PEM FH-M6-15ZI (Inside)
3	2.717	32.179	PEM FH-M6-15ZI (Inside)
4	2.717	34.305	PEM FH-M6-15ZI (Inside)

APPROVED FOR PRODUCTION
APPROUVÉ POUR PRODUCTION
 SIGNATURE: _____
 NAME / NOM: _____
 DATE: _____
 Please visit: www.boxcadexm.com

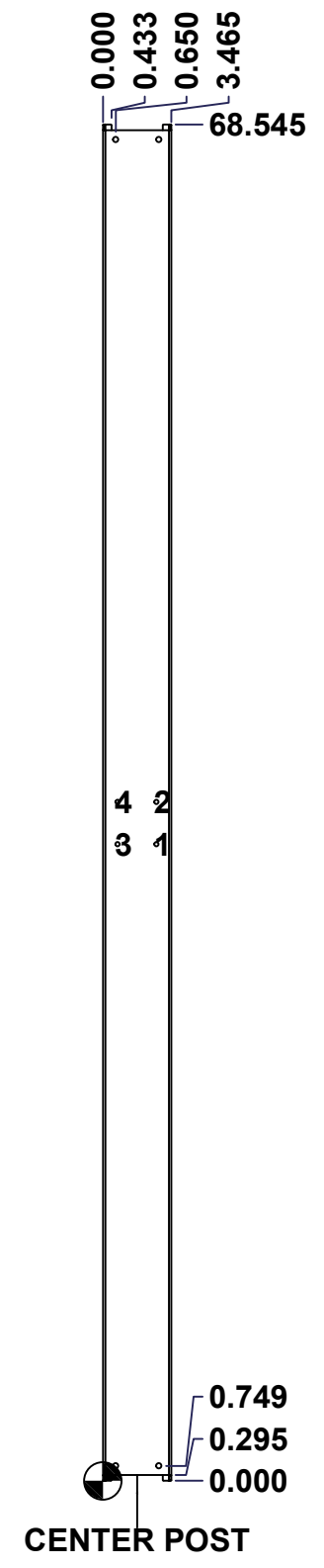

	Description	Status
	5412DDS 72" x 60" x 18" Body	(NULL)
Part Number Numéro Pièce 5412DDH726018B	Rev.	9
	0	18

This drawing is confidential and must not be reproduced or used without the consent of EXM

Ce dessin est confidentiel et ne doit pas être reproduit ou utilisé sans le consentement de EXM

APPROVED FOR PRODUCTION
APPROUVÉ POUR PRODUCTION
 SIGNATURE: _____
 NAME / NOM: _____
 DATE: _____
 Please visit: www.boxcadexm.com

No.	Revisions	Date	By/Par

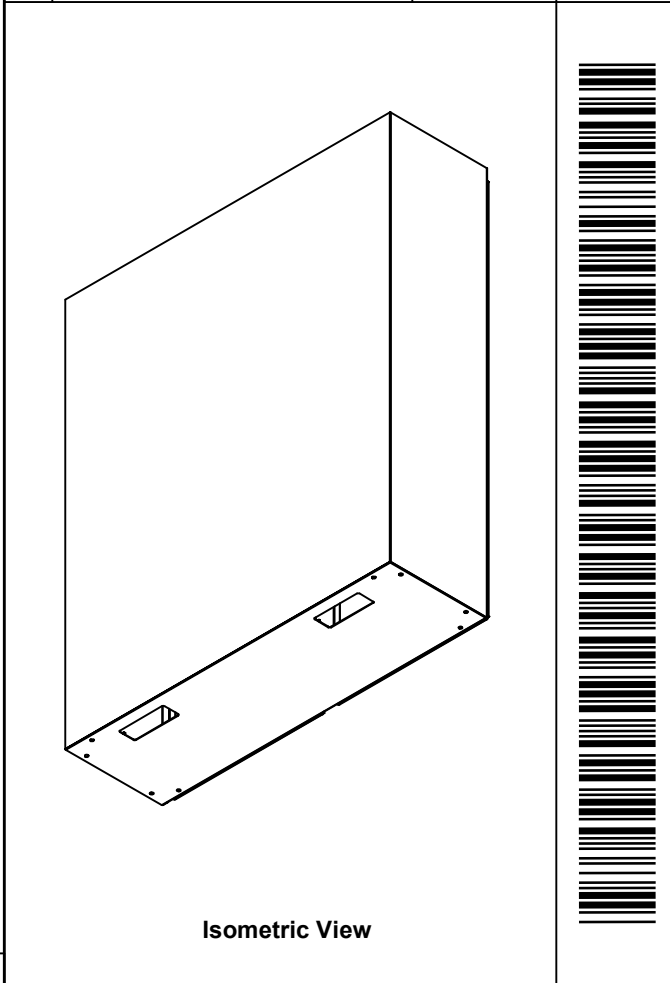

Isometric View

4	STK-Q-16030	0	Stud M6 x 10mm Steel
4	STK-PEM-FH-M6-15ZI	0	PEM Self-Clinching Stud M6 x 15.0mm
1	STK-P-02400R	0	Powder Paint (Asa-61 Grey / Rough Textured)
2	STK-Q-74900	0	Eyebolt Lifting Angle (8.750")
1	STK-A-75454	3	Center Post - Sealing Block with Latch Assembly (Large)
1	5412DDH726018CP-P	0	5412DDS 72" Center Post Part
2	STK-Q-07320	0	Flange Lock Nut M10
2	STK-Q-07618	1	5500 Series Inner Panel Support Bracket
8	STK-Q-16100	0	Stud M10 x 40mm Steel
1	5412DDH726018BT-P	0	5412DDS 60" x 18" Bottom Part
1	5412DDH726018T-P	0	5412DDS 60" x 18" Top Part
1	5412DDH726018RS-P	0	5412DDS 72" x 60" Right Part
1	5412DDH726018LS-P	0	5412DDS 72" x 60" Left Part
1	5412DDH726018B-P	0	5412DDS 72" x 60" Back Part
2	5412DDH726018_CR400 MS_21.5	0	Commercial Roll Mild Steel (21.5in long)
6	STK-Q-16080	0	Ground Stud M6 x 16mm Steel

Qty	Part Number	Rev	Description
Parts List			

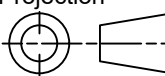
 Tél: (450) 979-4373 Fax: (450) 979-4626 www.exmweb.com	Flatness Aplatissement	Max 3.0mm
	Projection	
Customer Client	Date	
Drawn By Dessiné Par	BoxCad: slam	Date 12-Aug-25
Material Matière	12 Ga Cold Rolled A1008 CS Type B (2.5mm)	
Color Couleur	Asa-61 Grey	Finish Fini Rough Textured
Description	Detail Rev.	
5412DDS 72" x 60" x 18" Body		
Part Number Numéro Pièce	Rev.	10
5412DDH726018B	0	18

This drawing is confidential and must not be reproduced or used without the consent of EXM

Ce dessin est confidentiel et ne doit pas être reproduit ou utilisé sans le consentement de EXM

APPROVED FOR PRODUCTION
APPROUVÉ POUR PRODUCTION
 SIGNATURE: _____
 NAME / NOM: _____
 DATE: _____
 Please visit: www.boxcadexm.com

No.	Revisions	Date	By/Par



TOP



BACK

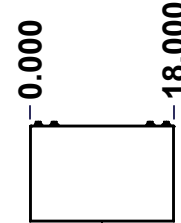

LEFT

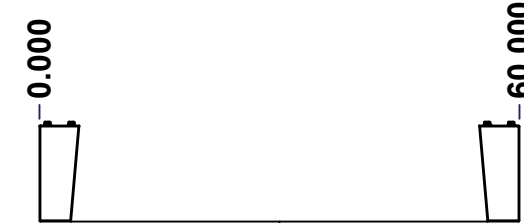

FRONT

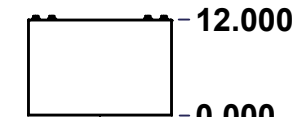

RIGHT

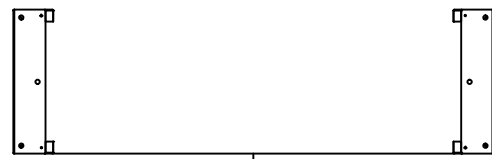

BOTTOM

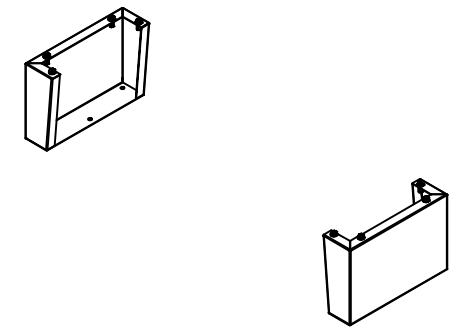

Isometric View

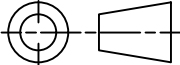

 Tél: (450) 979-4373 Fax: (450) 979-4626 www.exmweb.com		Flatness Aplatissement Max 3.0mm Projection 
Customer Client	Date	
Drawn By / Dessiné Par: BoxCad: slam	Date: 12-Aug-25	
Material / Matière: 12 Ga Cold Rolled A1008 CS Type B (2.5mm)		
Color / Couleur: Asa-61 Grey	Finish / Fini: Rough Textured	
Description: 885 MFHD 12" x 18" Mounting Feet		Detail Rev.
Part Number / Numéro Pièce: 5412DDH726018MF	Rev. 0	11 / 18

SEE BILL OF MATERIAL ON LAST PAGE

This drawing is confidential and must not be reproduced or used without the consent of EXM

Ce dessin est confidentiel et ne doit pas être reproduit ou utilisé sans le consentement de EXM

APPROVED FOR PRODUCTION
APPROUVÉ POUR PRODUCTION
 SIGNATURE: _____
 NAME / NOM: _____
 DATE: _____
 Please visit: www.boxcadexm.com

No.	Revisions	Date	By/Par

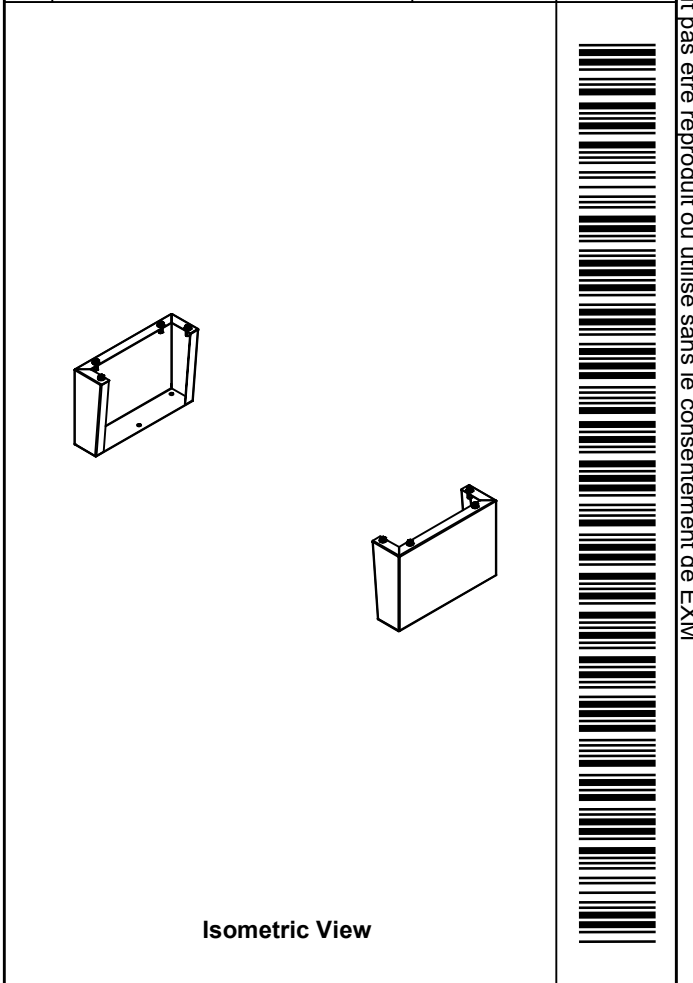

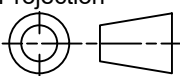
 Tél: (450) 979-4373 Fax: (450) 979-4626 www.exmweb.com		Flatness Aplatissement Max 3.0mm Projection 
Customer Client	Date	
Drawn By / Dessiné Par: BoxCad: slam	Date: 12-Aug-25	
Material / Matière: 12 Ga Cold Rolled A1008 CS Type B (2.5mm)		
Color / Couleur: Asa-61 Grey	Finish / Fini: Rough Textured	
Description: 885 MFHD 12" x 18" Mounting Feet		Detail Rev.
Part Number / Numéro Pièce: 5412DDH726018MF	Rev.: 0	12 / 18

Qty	Part Name	Rev	Description
1	STK-P-02400R	0	Powder Paint (Asa-61 Grey / Rough Textured)
8	RIVET_NUT_M10_FH_CE	0	Rivet Nut M10 (Low Profile Close End)
1	5412DDH726018MFR-P	0	885 MFHD 12" x 18" Right Mounting Feet Part
1	5412DDH726018MFL-P	0	885 MFHD 12" x 18" Left Mounting Feet Part
4	STK-K-11600	2	885 MF Accessory Kit
Parts List			

This drawing is confidential and must not be reproduced or used without the consent of EXM

Ce dessin est confidentiel et ne doit pas être reproduit ou utilisé sans le consentement de EXM

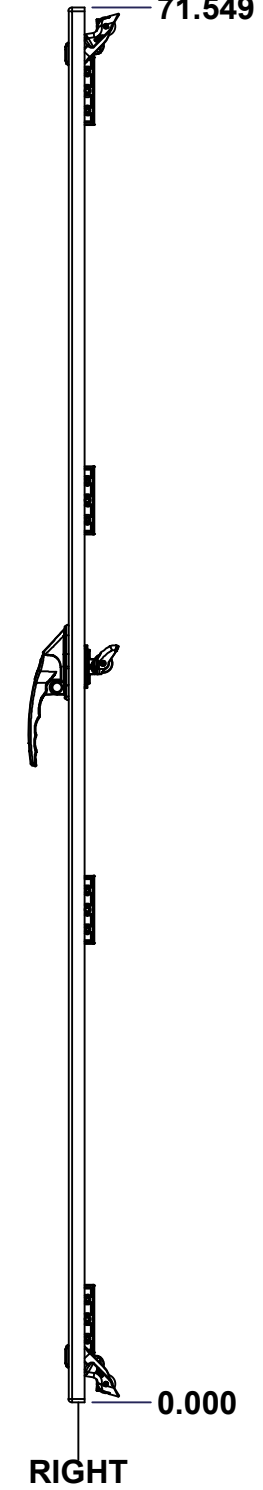
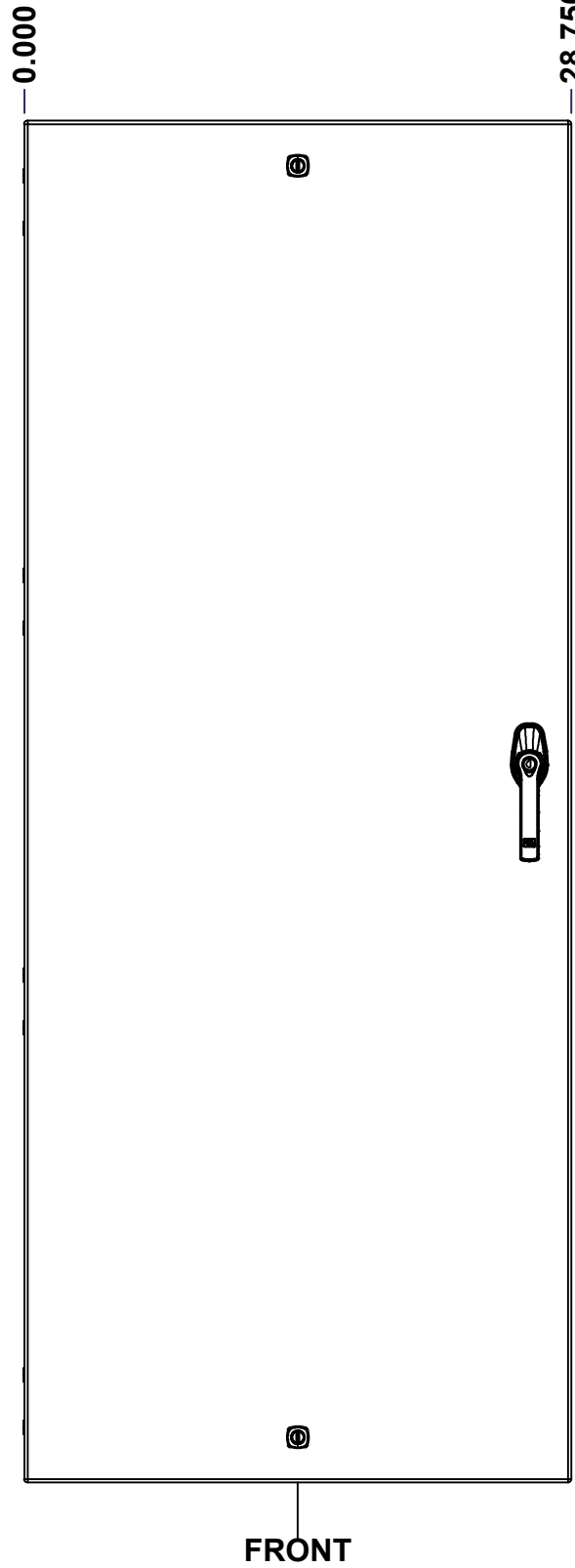
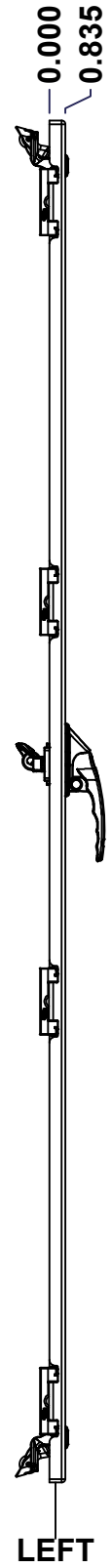
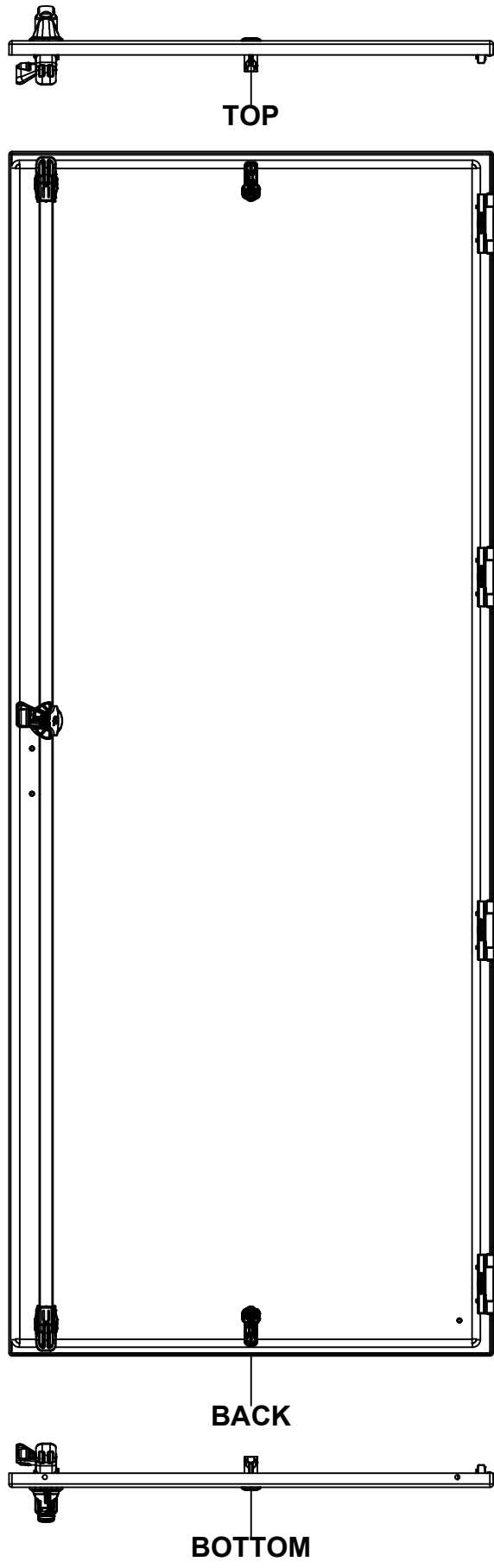

APPROVED FOR PRODUCTION
APPROUVÉ POUR PRODUCTION
 SIGNATURE: _____
 NAME / NOM: _____
 DATE: _____
 Please visit: www.boxcadexm.com

No.	Revisions	Date	By/Par

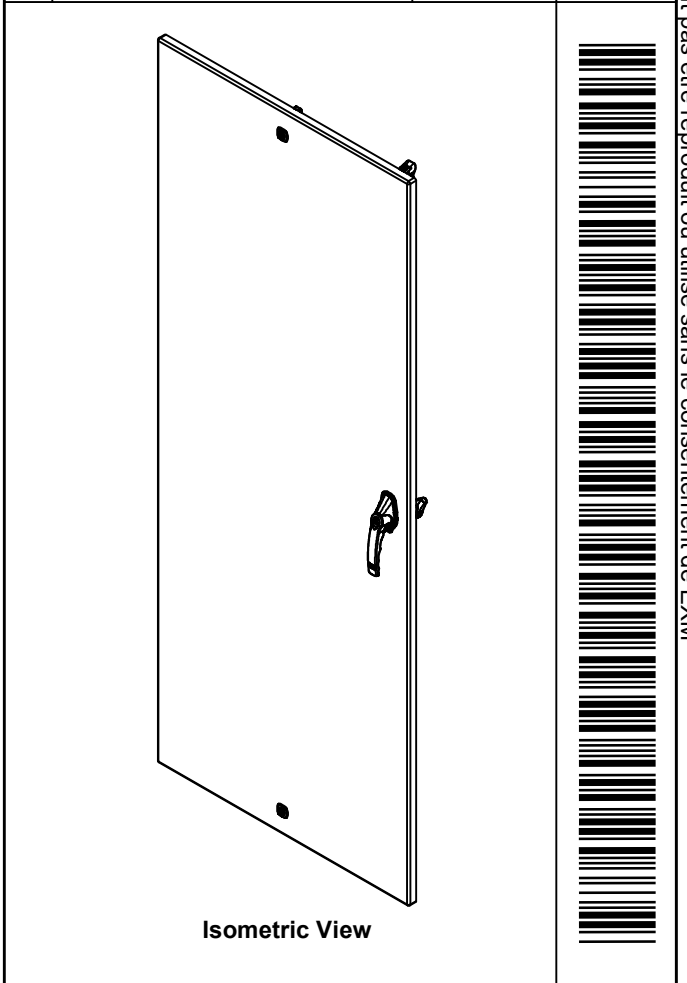

Tél: (450) 979-4373 Fax: (450) 979-4626 www.exmweb.com		Flatness Aplatissement
		Max 3.0mm
Customer Client Drawn By / Dessiné Par: BoxCad: slam Material / Matière: 12 Ga Cold Rolled A1008 CS Type B (2.5mm)		Projection
Date		Date
Date 12-Aug-25		Date
Color / Couleur: Asa-61 Grey		Finish / Fini: Rough Textured
Description: 5412DDS 72" x 60" Slave Door		Detail Rev.
Part Number / Numéro Pièce: 5412DDH726018LD		Rev. 13
SEE BILL OF MATERIAL ON LAST PAGE		0 18

This drawing is confidential and must not be reproduced or used without the consent of EXM

Ce dessin est confidentiel et ne doit pas être reproduit ou utilisé sans le consentement de EXM

STANDARD FEATURES ARE NOT LISTED IN THIS HOLE TABLE

HOLE TABLE - FRONT VIEW (CUSTOM FEATURE ONLY)

CUT-OUT	XDIM	YDIM	DESCRIPTION
1	26.546	6.118	LARGE CBAR GUIDE (Inside)
2	26.546	65.430	LARGE CBAR GUIDE (Inside)
-----	-----	-----	-----
3	26.546	37.743	HANDLE 885 ESL2A-APHK @ 0.0°
4	14.375	69.180	LOCK 889 SCQ4-SL @ 90.0°
5	14.375	2.368	LOCK 889 SCQ4-SL @ 270.0°
6	2.000	2.118	GND STUD M6 x 16mm (Inside)
7	27.372	33.404	STUDS M6 x 18mm (Inside)
8	27.372	36.082	STUDS M6 x 18mm (Inside)

APPROVED FOR PRODUCTION
APPROUVÉ POUR PRODUCTION
 SIGNATURE: _____
 NAME / NOM: _____
 DATE: _____
 Please visit: www.boxcadexm.com

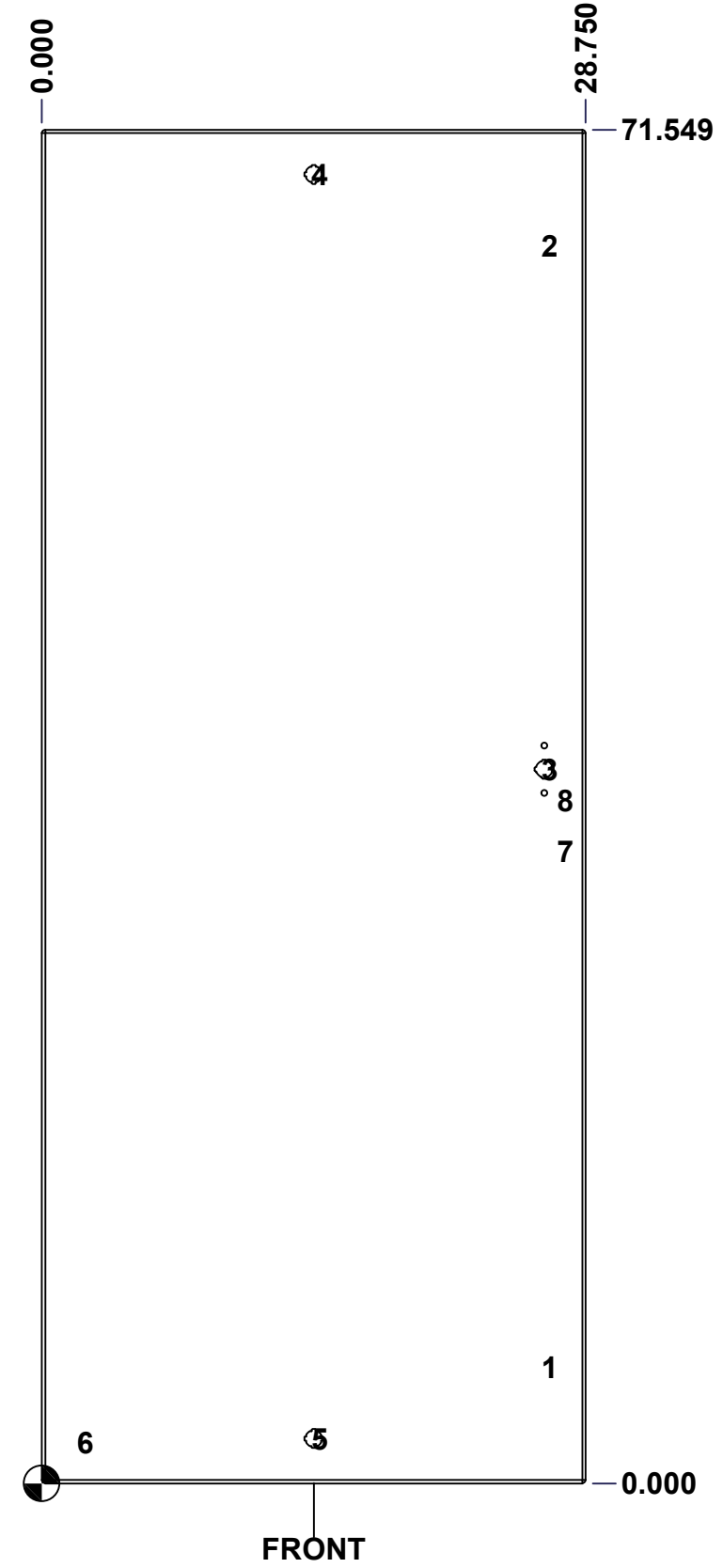

	Description	Status
	5412DDS 72" x 60" Slave Door	(NULL)
	Part Number Numéro Pièce	Rev.
	5412DDH726018LD	0 / 14
		18

This drawing is confidential and must not be reproduced or used without the consent of EXM

Ce dessin est confidentiel et ne doit pas être reproduit ou utilisé sans le consentement de EXM

APPROVED FOR PRODUCTION
APPROUVÉ POUR PRODUCTION
 SIGNATURE: _____
 NAME / NOM: _____
 DATE: _____
 Please visit: www.boxcadexm.com

No.	Revisions	Date	By/Par

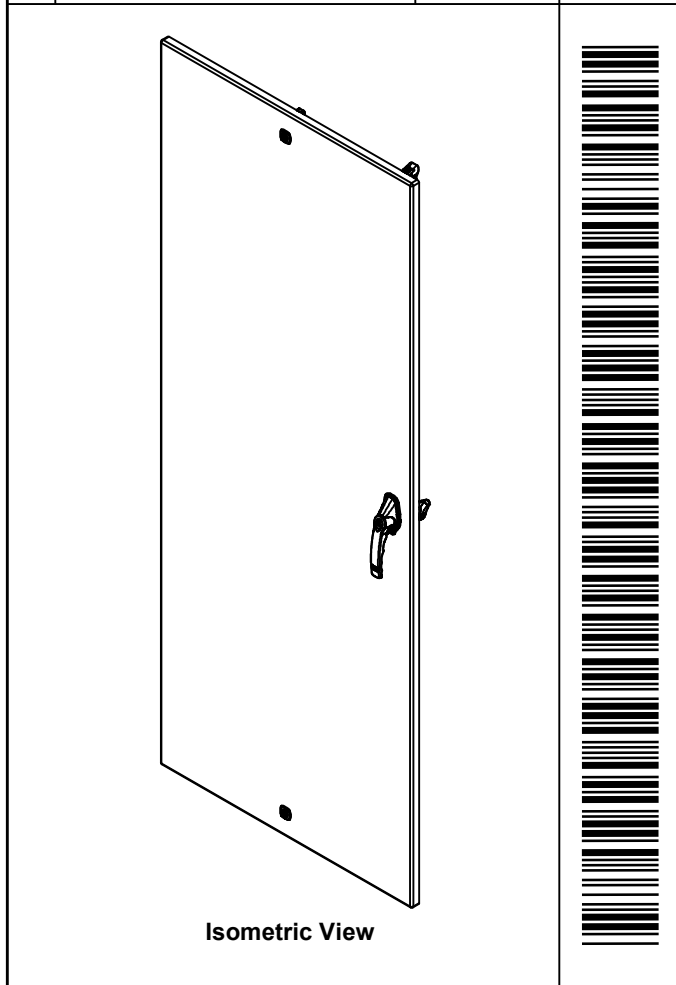

2	STK-Q-16050	1	Stud M6 x 18mm Steel
1	STK-Q-16080	0	Ground Stud M6 x 16mm Steel
2	STK-Q-07220	1	M6 Nylon Insert Lock Nut
1	STK-Q-47542	1	5500 DDS Lower Closing Bar 72"
1	STK-Q-47532	0	5500 DDS Upper Closing Bar 72"
1	STK-A-50538	3	9500 Handle Cam Assembly (Right Side, Grip 36mm)
1	STK-Q-90051	3	5412 ES - Handle Cam Spacer
1	885ESL2A-APHK	7	885 ESL2A-APHK - Zinc Die Cast L-Handle Padlockable Assy
1	STK-P-02400R	0	Powder Paint (Asa-61 Grey / Rough Textured)
2	STK-Q-16410	0	Guide Stud - Largel (No Paint Cap Required)
1	5412DDH726018DG	0	5412DDS 72" x 60" Door Gasket
1	5412DDH726018LD-P	0	5412DDS 72" x 60" Slave Door Part
2	STK-A-90025	0	9500 - Cabinet Closing Bar End (Large)
4	STK-K-09860	7	Cabinet Hinge with Captive Pins
2	STK-K-12580	0	9412 1/4 Turn Lock

QTY	Part Number	Rev	Description
Parts List			

Tél: (450) 979-4373 Fax: (450) 979-4626 www.exmweb.com	Flatness Aplatissement	Max 3.0mm
	Projection	
Customer Client	Date	
Drawn By Dessiné Par	BoxCad: slam	Date 12-Aug-25
Material Matière	12 Ga Cold Rolled A1008 CS Type B (2.5mm)	
Color Couleur	Asa-61 Grey	Finish Fini Rough Textured
Description	Detail Rev.	
5412DDS 72" x 60" Slave Door		
Part Number Numéro Pièce	Rev.	15
5412DDH726018LD	0	18

This drawing is confidential and must not be reproduced or used without the consent of EXM

Ce dessin est confidentiel et ne doit pas être reproduit ou utilisé sans le consentement de EXM

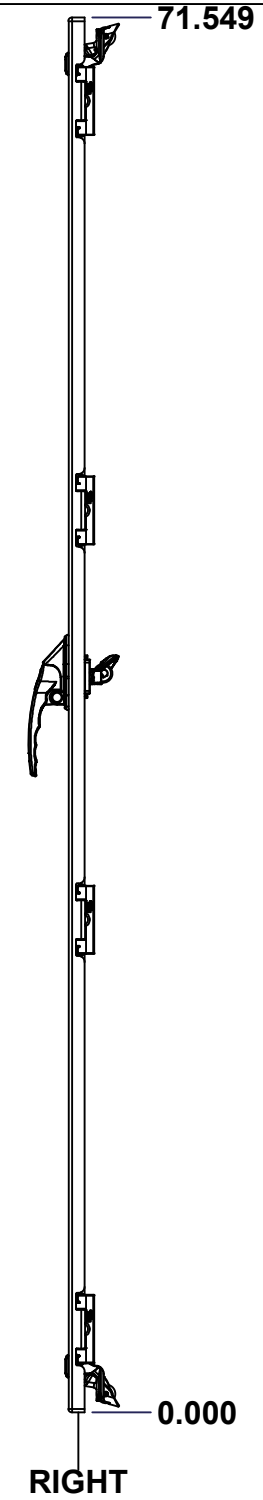
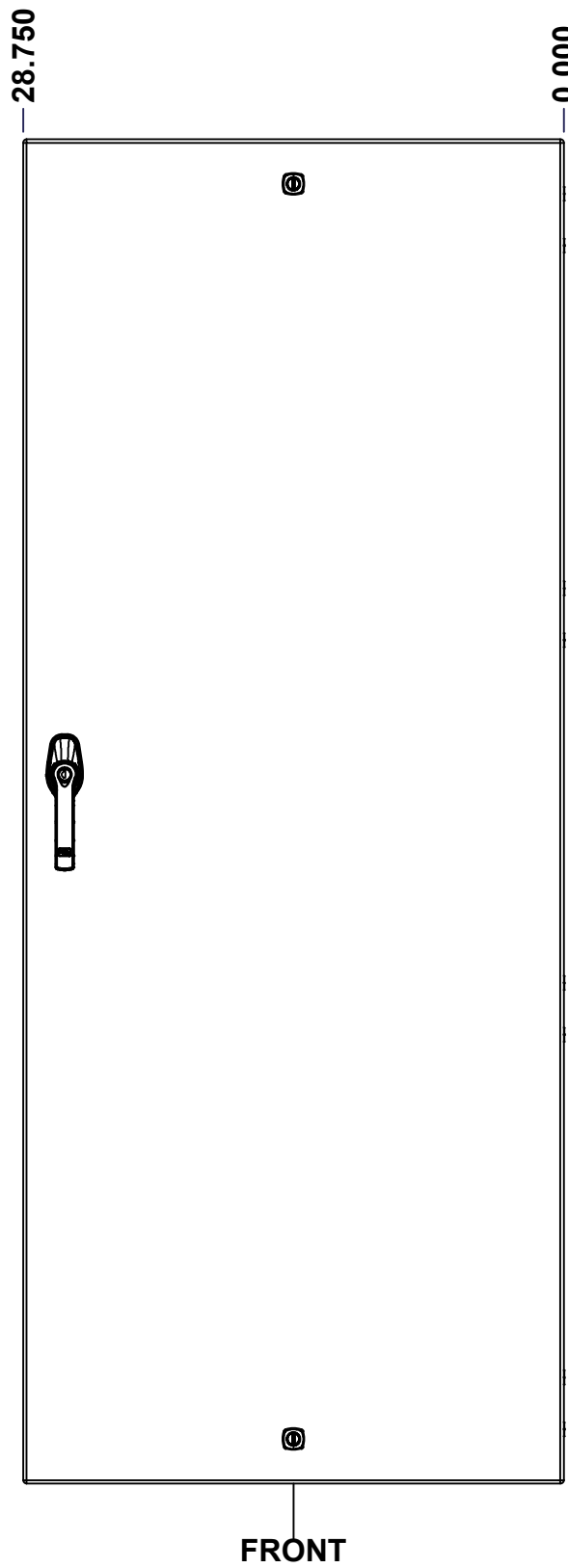
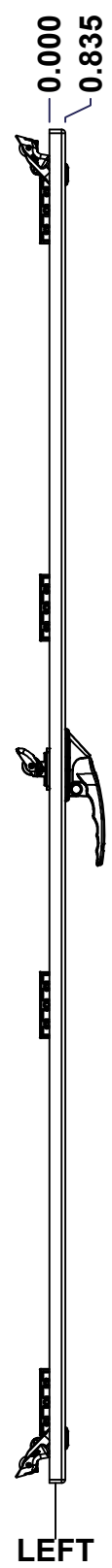
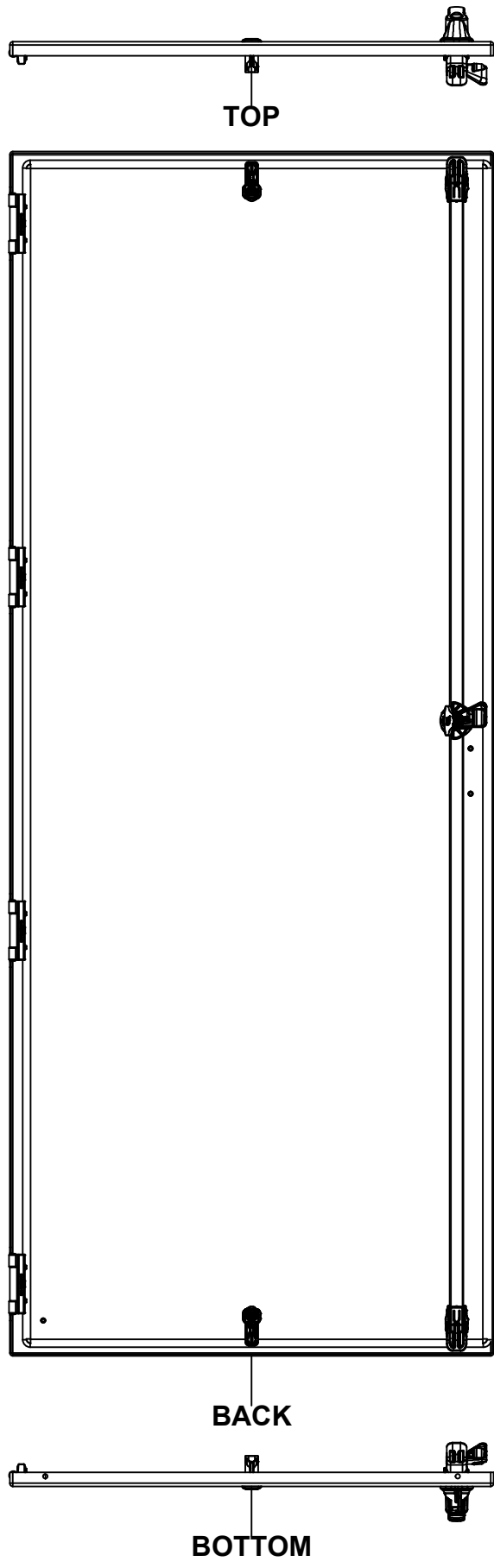

APPROVED FOR PRODUCTION
APPROUVÉ POUR PRODUCTION
 SIGNATURE: _____
 NAME / NOM: _____
 DATE: _____
 Please visit: www.boxcadexm.com

No.	Revisions	Date	By/Par

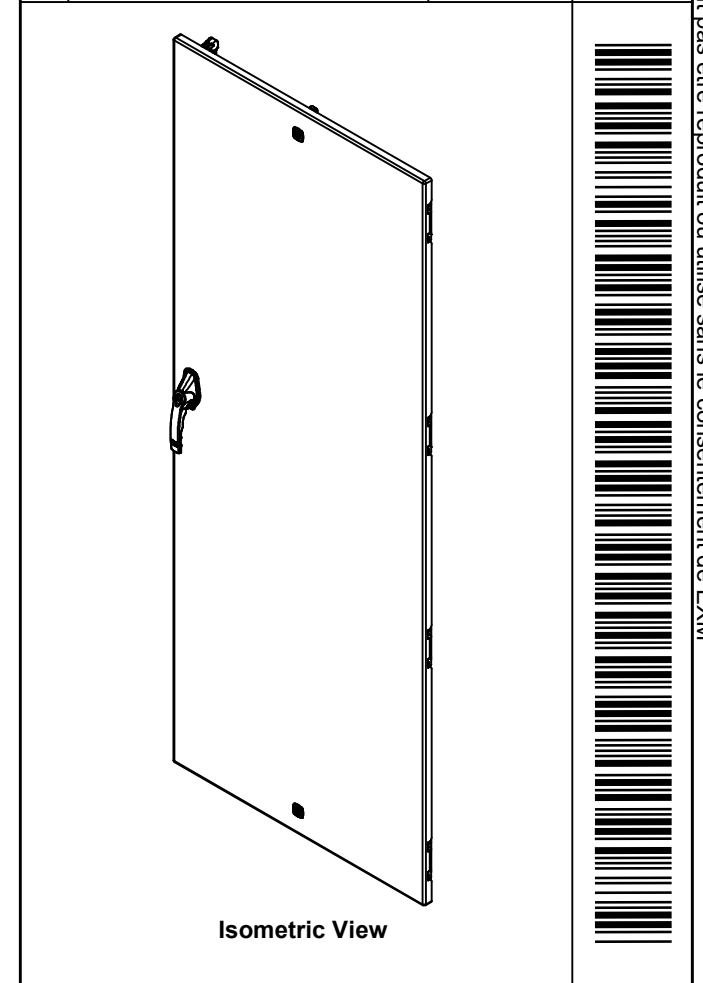

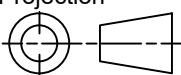
 Tél: (450) 979-4373 Fax: (450) 979-4626 www.exmweb.com		Flatness Aplatissement	
		Max 3.0mm	
Customer Client		Projection	
Date			
Drawn By Dessiné Par BoxCad: slam		Date 12-Aug-25	
Material Matière 12 Ga Cold Rolled A1008 CS Type B (2.5mm)			
Color Couleur Asa-61 Grey		Finish Fini Rough Textured	
Description 5412DDS 72" x 60" Master Door			Detail Rev.
Part Number Numéro Pièce 5412DDH726018FD		Rev. 0	16 / 18

SEE BILL OF MATERIAL ON LAST PAGE

This drawing is confidential and must not be reproduced or used without the consent of EXM

Ce dessin est confidentiel et ne doit pas être reproduit ou utilisé sans le consentement de EXM

STANDARD FEATURES ARE NOT LISTED IN THIS HOLE TABLE

HOLE TABLE - FRONT VIEW (CUSTOM FEATURE ONLY)

CUT-OUT	XDIM	YDIM	DESCRIPTION
1	26.546	6.118	LARGE CBAR GUIDE (Inside)
2	26.546	65.430	LARGE CBAR GUIDE (Inside)
-----	-----	-----	-----
3	26.546	37.743	HANDLE 885 ESL2A-APHK
4	14.375	69.180	LOCK 889 SCQ4-SL @ 90.0°
5	14.375	2.368	LOCK 889 SCQ4-SL @ 270.0°
6	2.000	2.118	GND STUD M6 x 16mm (Inside)
7	27.372	33.404	STUDS M6 x 18mm (Inside)
8	27.372	36.082	STUDS M6 x 18mm (Inside)

APPROVED FOR PRODUCTION
APPROUVÉ POUR PRODUCTION
 SIGNATURE: _____
 NAME / NOM: _____
 DATE: _____
 Please visit: www.boxcadexm.com

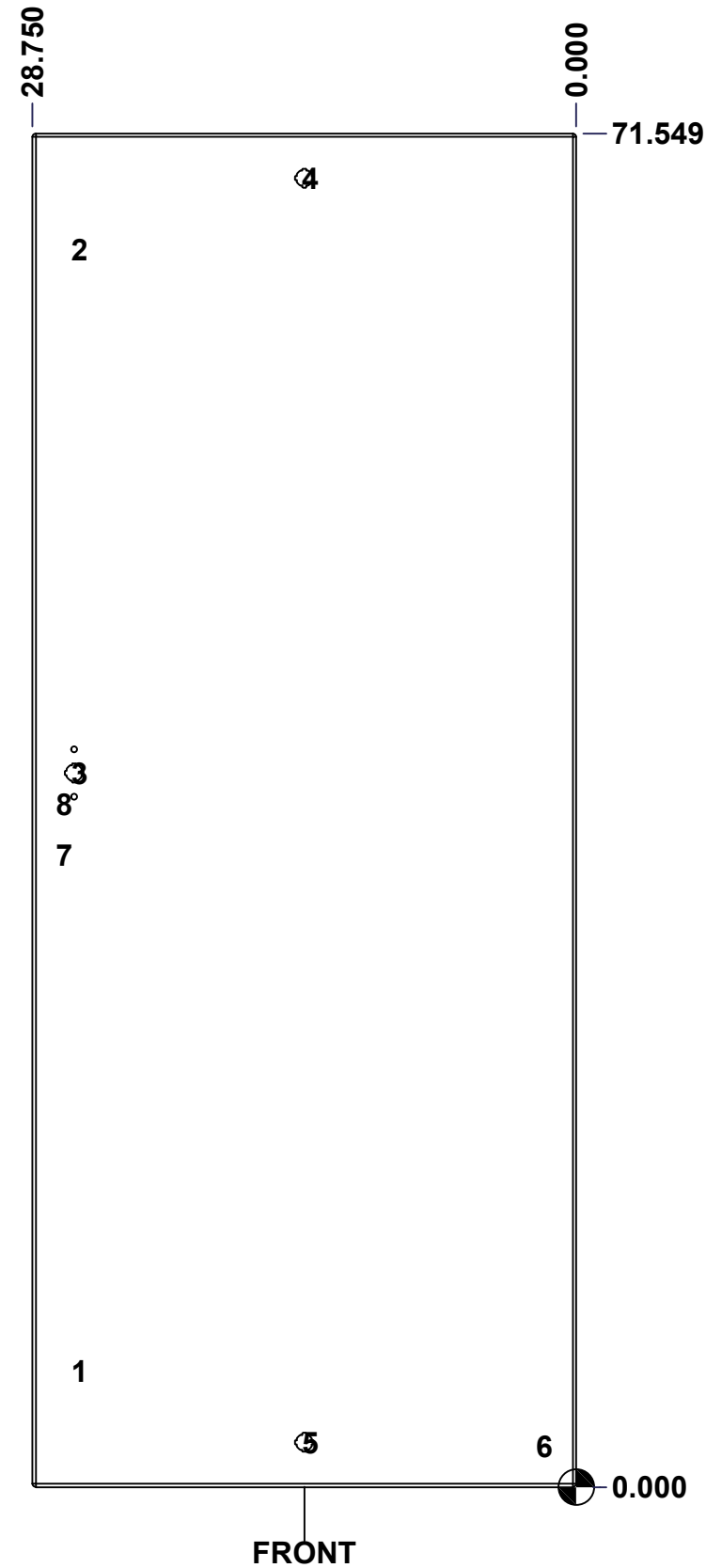

FRONT

	Description	Status
	5412DDS 72" x 60" Master Door	(NULL)
	Part Number Numéro Pièce	Rev.
	5412DDH726018FD	0 / 17
		18

This drawing is confidential and must not be reproduced or used without the consent of EXM

Ce dessin est confidentiel et ne doit pas être reproduit ou utilisé sans le consentement de EXM

APPROVED FOR PRODUCTION
APPROUVÉ POUR PRODUCTION
 SIGNATURE: _____
 NAME / NOM: _____
 DATE: _____
 Please visit: www.boxcadexm.com

No.	Revisions	Date	By/Par

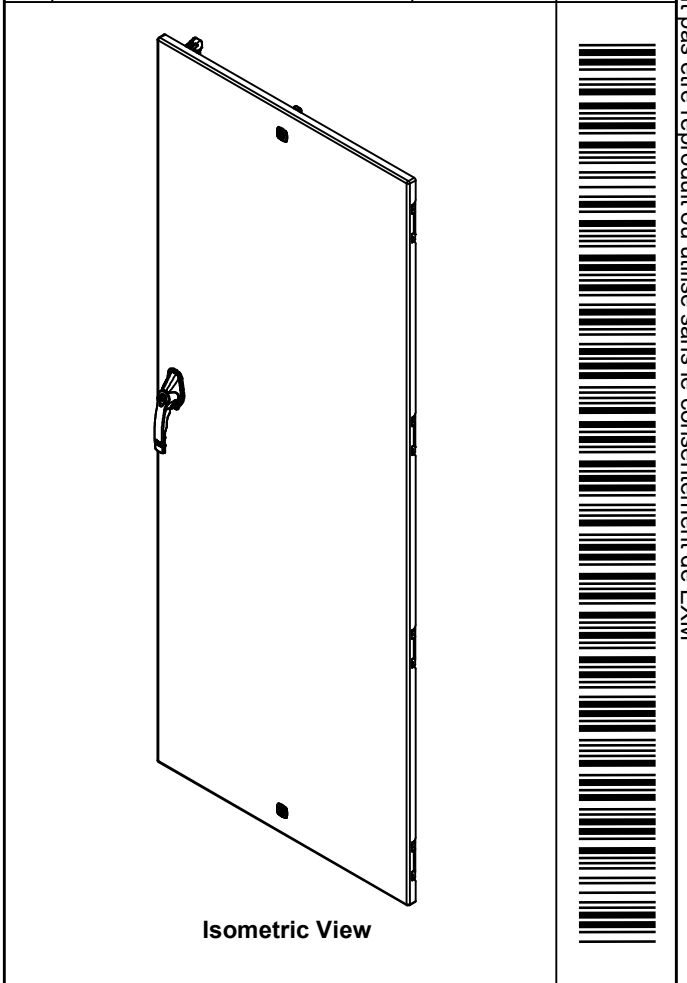

2	STK-Q-16050	1	Stud M6 x 18mm Steel
1	STK-Q-16080	0	Ground Stud M6 x 16mm Steel
2	STK-Q-07220	1	M6 Nylon Insert Lock Nut
1	STK-Q-47542	1	5500 DDS Lower Closing Bar 72"
1	STK-Q-47532	0	5500 DDS Upper Closing Bar 72"
1	STK-A-50537	3	9500 Handle Cam Assembly (Left Side, Grip 36mm)
1	STK-Q-90051	3	5412 ES - Handle Cam Spacer
1	885ESL2A-APHK	7	885 ESL2A-APHK - Zinc Die Cast L-Handle Padlockable Assy
1	STK-P-02400R	0	Powder Paint (Asa-61 Grey / Rough Textured)
2	STK-Q-16410	0	Guide Stud - Largel (No Paint Cap Required)
1	5412DDH726018DG	0	5412DDS 72" x 60" Door Gasket
1	5412DDH726018FD-P	0	5412DDS 72" x 60" Master Door Part
2	STK-A-90025	0	9500 - Cabinet Closing Bar End (Large)
4	STK-K-09860	7	Cabinet Hinge with Captive Pins
2	STK-K-12580	0	9412 1/4 Turn Lock

QTY	Part Number	Rev	Description
Parts List			



Tél: (450) 979-4373
 Fax: (450) 979-4626
www.exmweb.com

Flatness
Aplatissement
Max 3.0mm

Projection

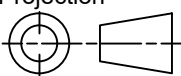

Customer Client	Date
Drawn By Dessiné Par BoxCad: slam	Date 12-Aug-25
Material Matière 12 Ga Cold Rolled A1008 CS Type B (2.5mm)	
Color Couleur Asa-61 Grey	Finish Fini Rough Textured
Description 5412DDS 72" x 60" Master Door	Detail Rev.
Part Number Numéro Pièce 5412DDH726018FD	Rev. 18 0 18

This drawing is confidential and must not be reproduced or used without the consent of EXM

Ce dessin est confidentiel et ne doit pas être reproduit ou utilisé sans le consentement de EXM

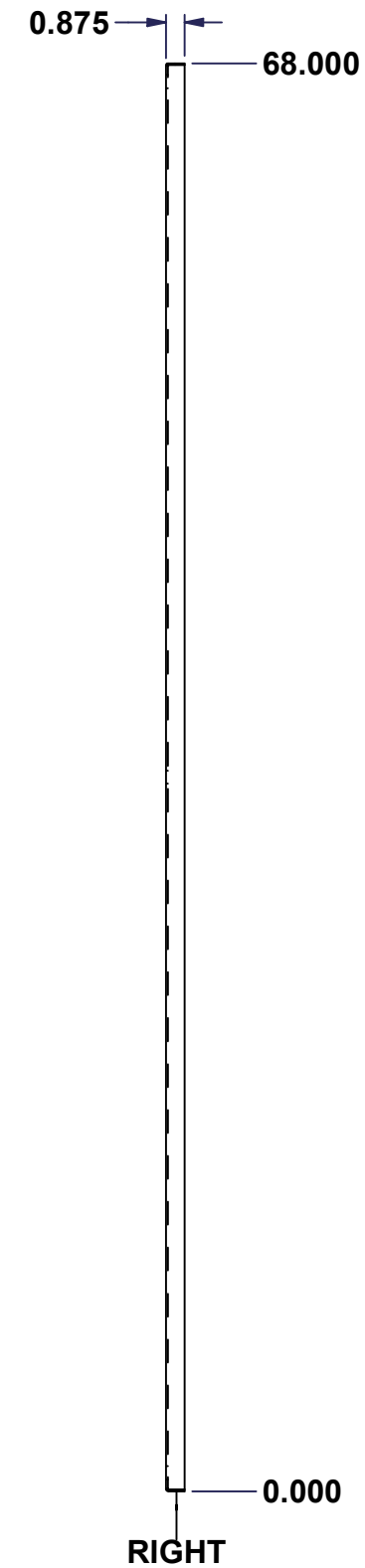
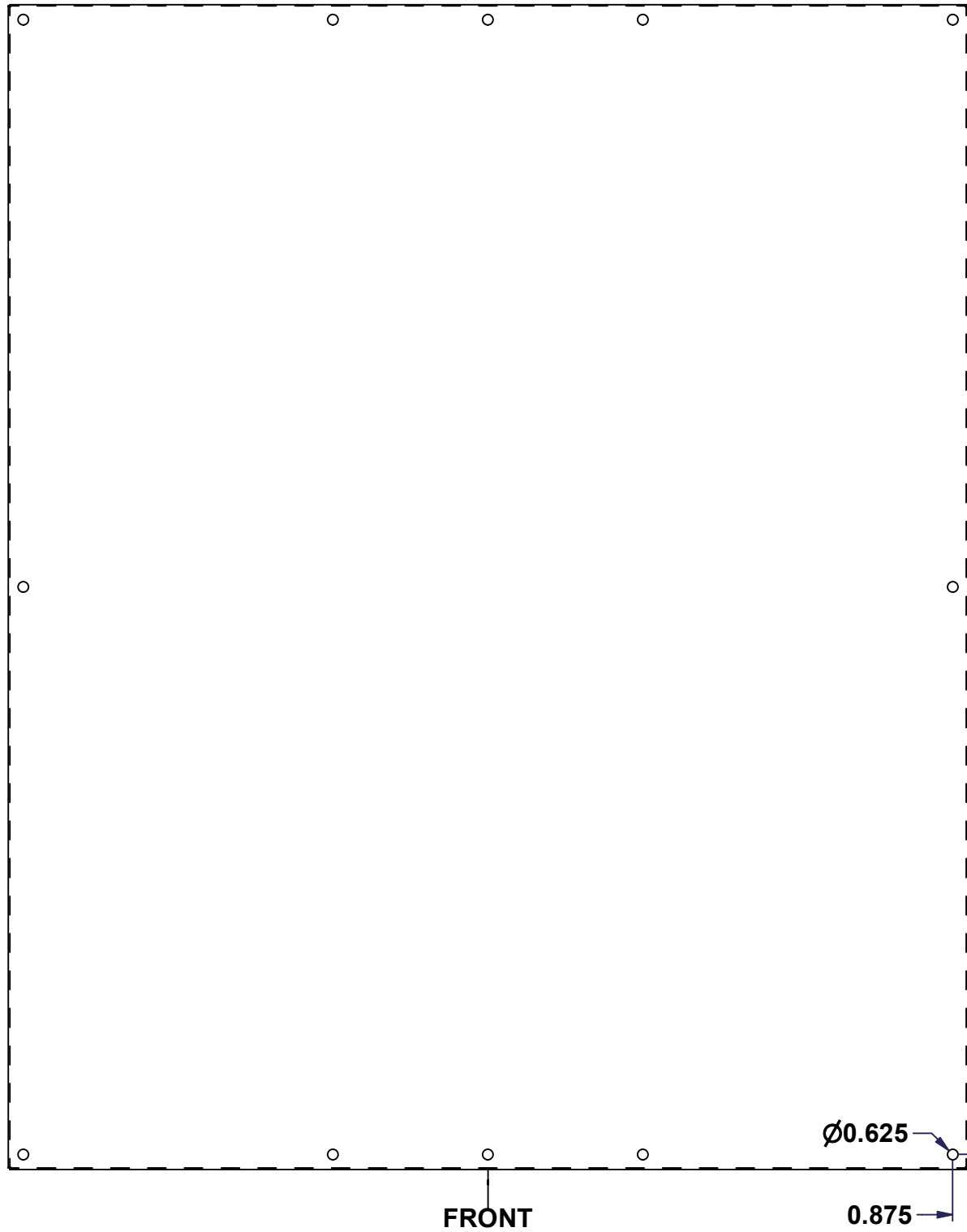
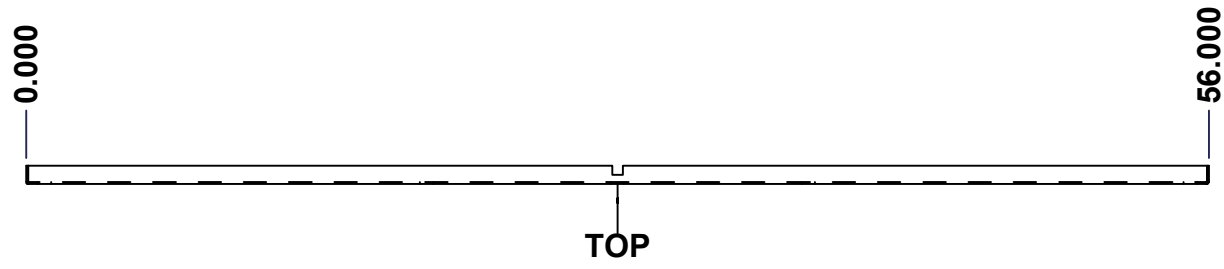

No.	Revisions	Date	By/Par

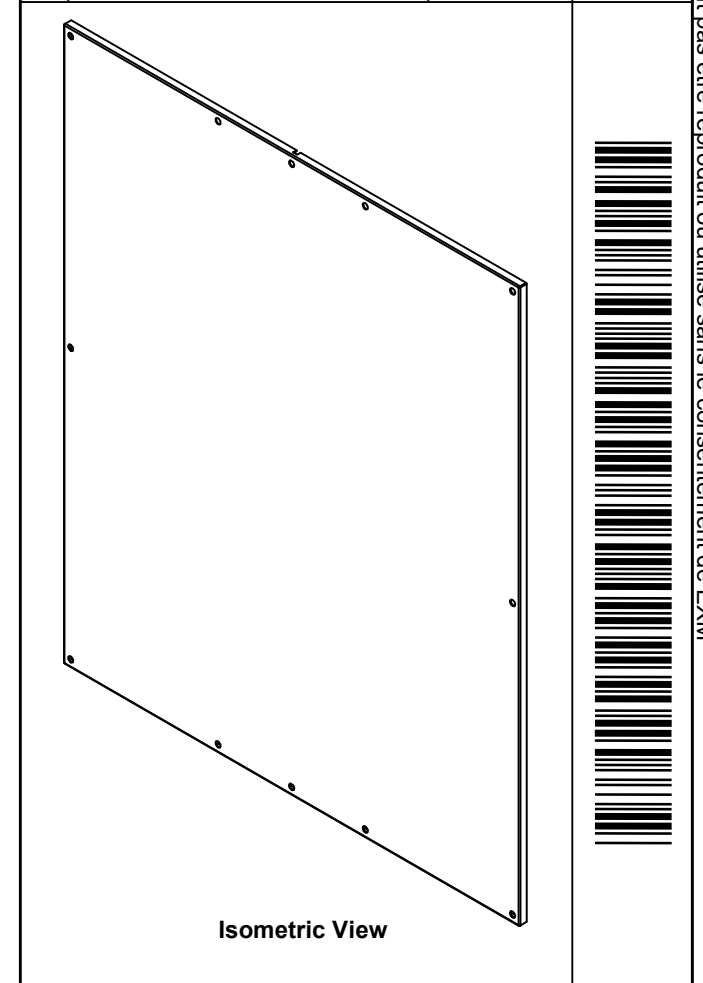

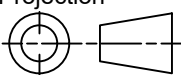
 Tél: (450) 979-4373 Fax: (450) 979-4626 www.exmweb.com	Flatness Aplatissement Max 3.0mm
	Projection 
Customer Client	Date
Drawn By Dessiné Par BoxCad	Date 04/11/2009
Material Matière 12 Ga Galvanized (2.5mm)	
Color Couleur Unpainted	Finish Fini Unpainted
Description 885 SP7260G Inner Panel	
Part Number Numéro Pièce 885SP7260G	Detail Rev.
Rev. 0	1 2

SEE BILL OF MATERIAL ON LAST PAGE

This drawing is confidential and must not be reproduced or used without the consent of EXM

Ce dessin est confidentiel et ne doit pas être reproduit ou utilisé sans le consentement de EXM

No.	Revisions	Date	By/Par

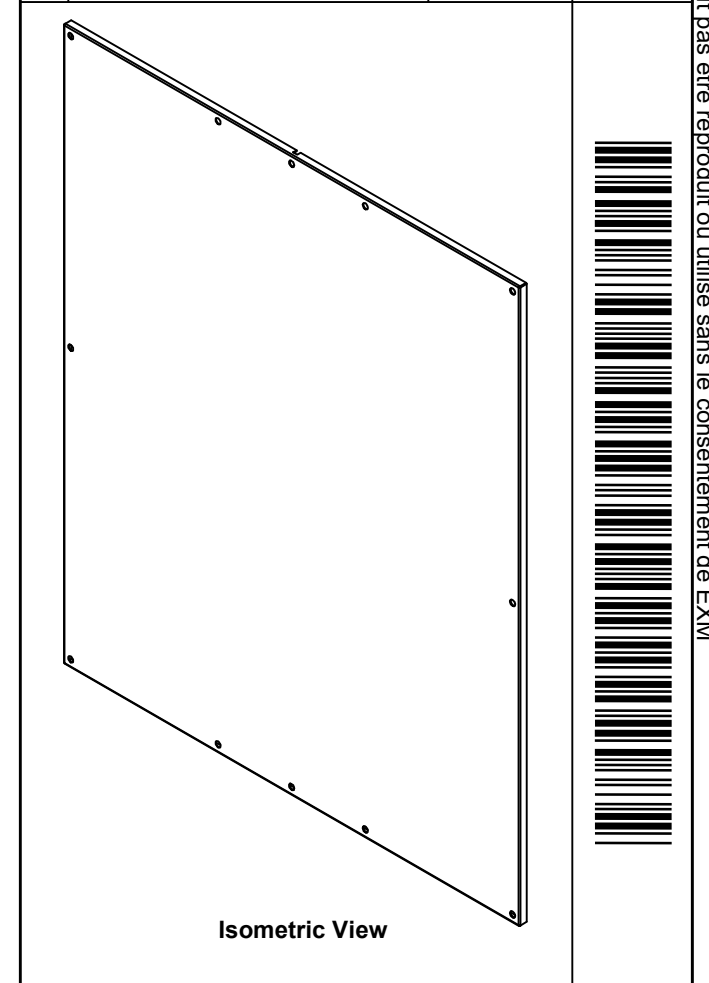

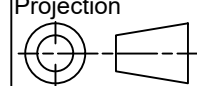
 Tél: (450) 979-4373 Fax: (450) 979-4626 www.exmweb.com		Flatness Aplatissement Max 3.0mm
Customer Client		Projection 
Drawn By / Dessiné Par: BoxCad		Date: 04/11/2009
Material / Matière: 12 Ga Galvanized (2.5mm)		
Color / Couleur: Unpainted	Finish / Fini: Unpainted	
Description: 885 SP7260G Inner Panel		Detail Rev.
Part Number / Numéro Pièce: 885SP7260G		Rev. 0 / 2

Qty	Part Number	Rev	Description
1	885SP7260G-P	0	885 SP7260G Inner Panel Part
Parts List			