

This drawing is confidential and must not be reproduced or used without the consent of EXM

Ce dessin est confidentiel et ne doit pas être reproduit ou utilisé sans le consentement de EXM

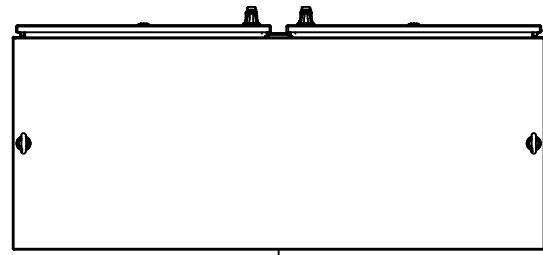

TOP

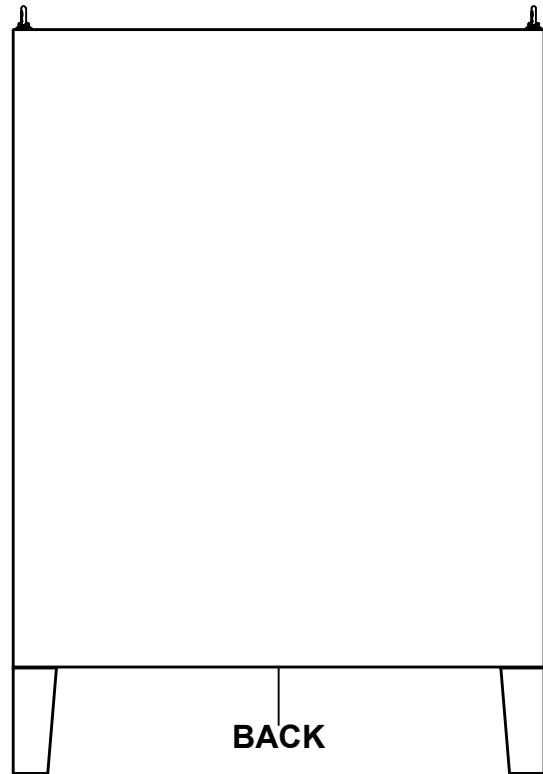

BACK

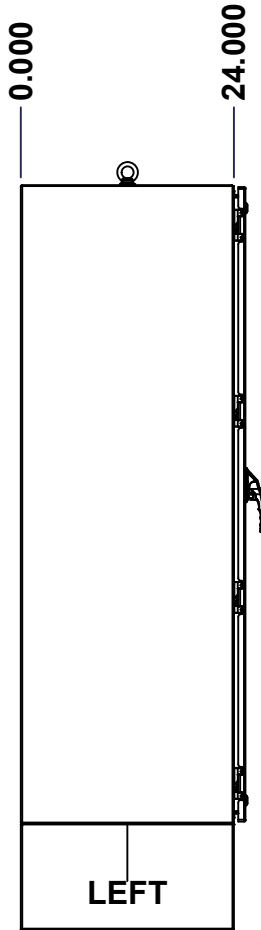

LEFT

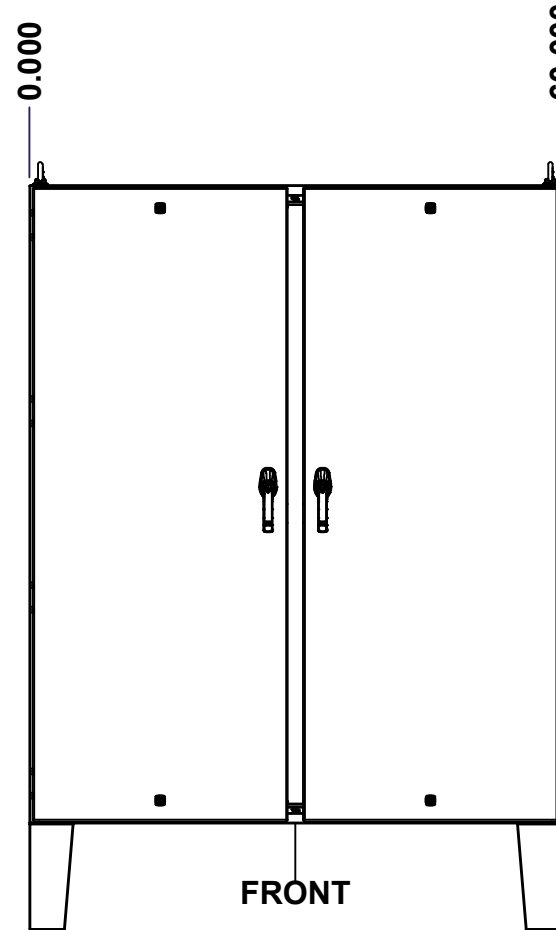

FRONT

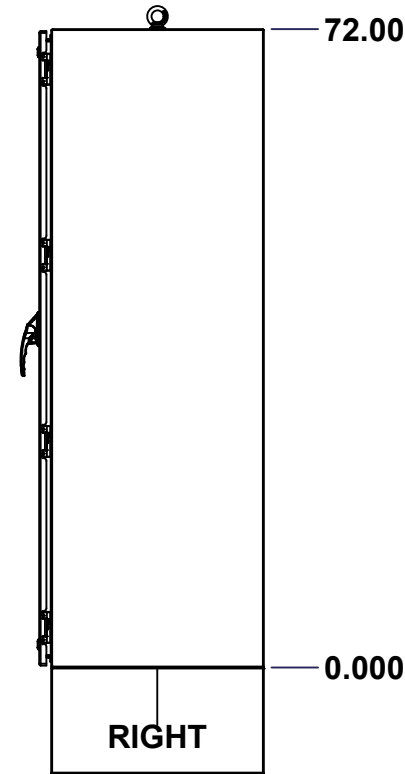

RIGHT

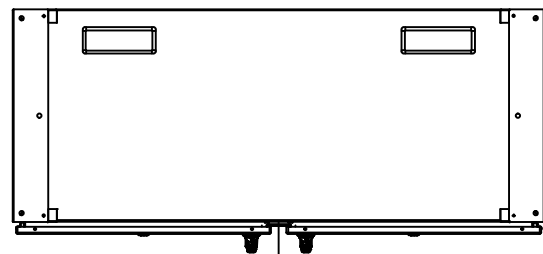

BOTTOM

No.	Revisions	Date	By/Par

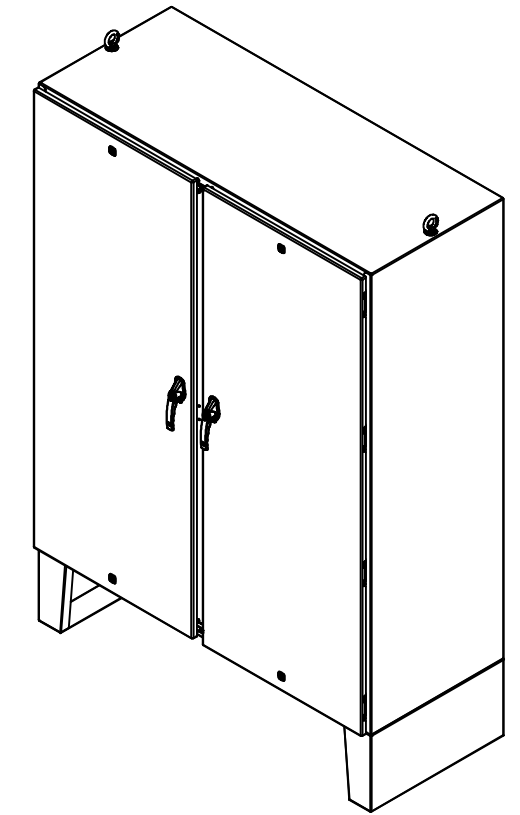

Isometric View

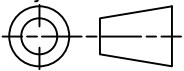

 Tél: (450) 979-4373 Fax: (450) 979-4626 www.exmweb.com		Flatness Aplatissement Max 3.0mm Projection 
Customer Client	Date	
Drawn By Dessiné Par	BoxCad: BoxCad	Date 25-Jul-24
Material Matière	12 Ga Cold Rolled A1008 CS Type B (2.5mm)	
Color Couleur	Asa-61 Grey	Finish Fini Smooth
Description		Detail Rev.
5412DDS 72" x 60" x 24" Assembly		
Part Number Numéro Pièce	Rev. 0	1 / 18

SEE BILL OF MATERIAL ON LAST PAGE

5412DDH726024

This drawing is confidential and must not be reproduced or used without the consent of EXM

Ce dessin est confidentiel et ne doit pas être reproduit ou utilisé sans le consentement de EXM

NOTE	
ITEM	DESCRIPTION
1	NEMA 4, 12 Enclosure (IP66)
2	C/W Standard ground studs on box and cover
3	W/O Standard door stiffener
4	C/W Standard inner panel (Sold separately)
5	C/W Standard inner panel mounting studs
6	C/W Eyebolts sold separately (Installed by EXM)
7	C/W Mounting feet sold separately (Installed)
8	C/W Special handle sold separately (Kit)
9	C/W Struts Welded (Included)
10	C/W Interlock Kit (Installed by EXM)

No.	Revisions	Date	By/Par

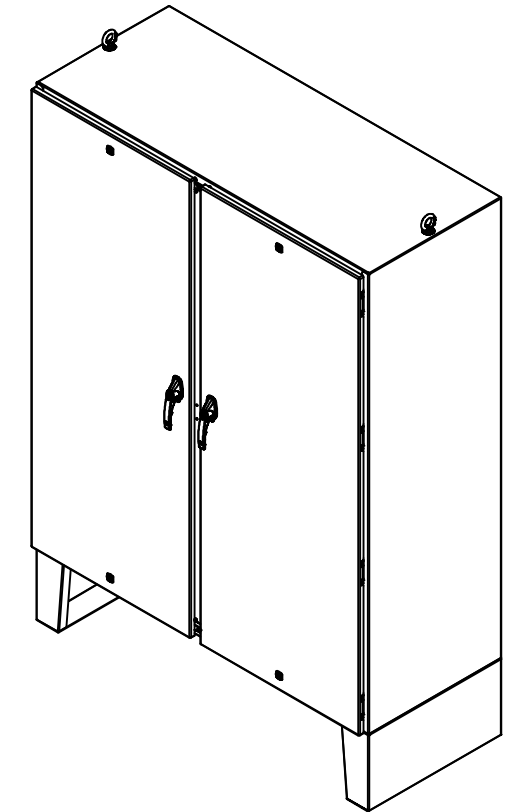

Isometric View



PACKING		
ITEM	QTY	DESCRIPTION
Cardboard sleeve	2	Top and Bottom
Cardboard strip	2	Between back of enclosure and inner panel
Plastic bag	1	To protect cover surface and inside gasket
Cardboard corner	4	To reinforced for the plastic strap tightening
Plastic strap - Black	2	To Squeeze the 2 cardboard sleeve together
Packaging label	3	White label with PN
Plastic strap- Green	2	To secure the enclosure to the wood pallet
Wood Pallet	1	2" deeper and 3" larger than enclosure size

1	885MFHD1224	0	885 MFHD 12" x 24" Mounting Feet
1	880EB14	2	Eye Bolt M14 (Pack of 2)
2	5412DDH726024GP	0	5412DDS Gland Plate
1	880INTI	4	880 INTI - Interlock Post Kit
8	STK-Q-07320	0	Flange Lock Nut M10
1	885SP7260G	0	885 SP7260G Inner Panel
8	STK-Q-07620	0	M10 Plastic Spacer 0.875"
8	STK-Q-04050-10	8	M6 x 10mm Hexagon Socket Head Machine Screw with Nyseal
1	5412DDH726024FD	0	5412DDS 72" x 60" Master Door
1	5412DDH726024LD	0	5412DDS 72" x 60" Slave Door
1	5412DDH726024B	0	5412DDS 72" x 60" x 24" Body
Qty	Part Number	Rev	Description
Parts List			



Tél: (450) 979-4373
Fax: (450) 979-4626
www.exmweb.com

Flatness
Aplatissement
Max 3.0mm

Projection

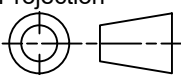

Customer Client	Date
Drawn By Dessiné Par BoxCad: BoxCad	Date 25-Jul-24
Material Matière 12 Ga Cold Rolled A1008 CS Type B (2.5mm)	
Color Couleur Asa-61 Grey	Finish Fini Smooth
Description 5412DDS 72" x 60" x 24" Assembly	Detail Rev.
Part Number Numéro Pièce 5412DDH726024	Rev. 0

This drawing is confidential and must not be reproduced or used without the consent of EXM

Ce dessin est confidentiel et ne doit pas être reproduit ou utilisé sans le consentement de EXM

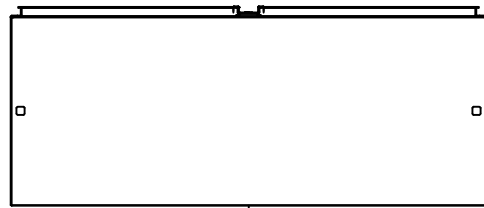

TOP

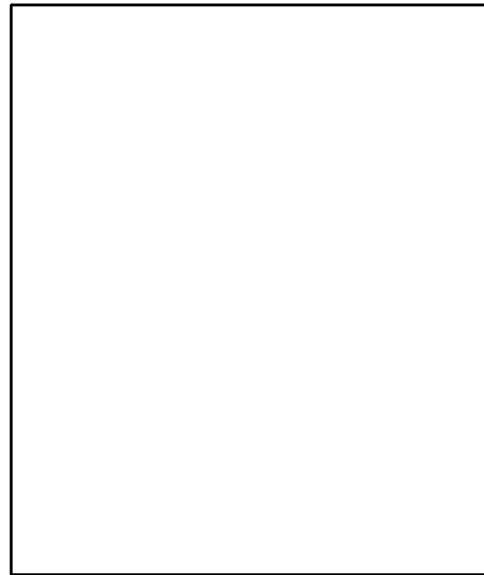

BACK

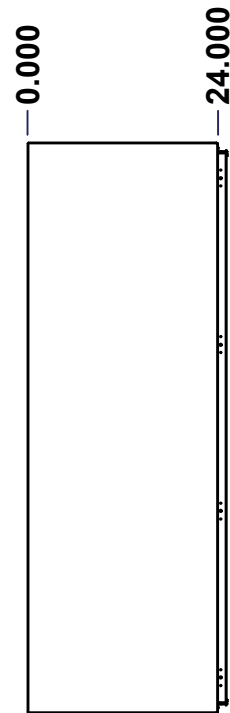

LEFT

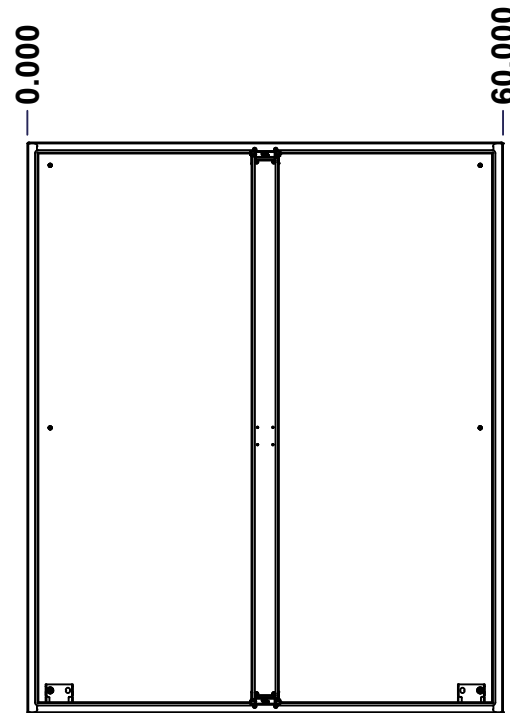

FRONT

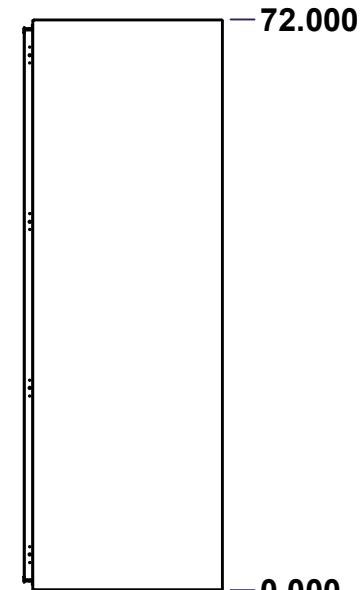

RIGHT

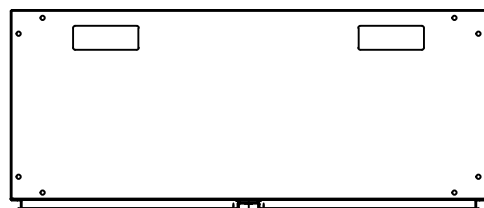

BOTTOM

No.	Revisions	Date	By/Par

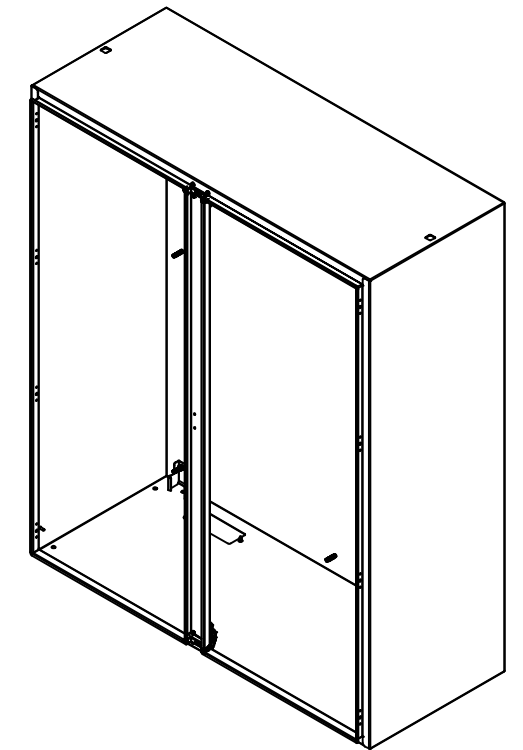

Isometric View

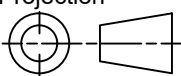

 Tél: (450) 979-4373 Fax: (450) 979-4626 www.exmweb.com		Flatness Aplatissement Max 3.0mm Projection 
Customer Client	Date	
Drawn By Dessiné Par	BoxCad: BoxCad	Date 25-Jul-24
Material Matière	12 Ga Cold Rolled A1008 CS Type B (2.5mm)	
Color Couleur	Asa-61 Grey	Finish Fini Smooth
Description	Detail Rev.	
5412DDS 72" x 60" x 24" Body		
Part Number Numéro Pièce	Rev. 0	3 / 18

SEE BILL OF MATERIAL ON LAST PAGE

5412DDH726024B

This drawing is confidential and must not be reproduced or used without the consent of EXM

Ce dessin est confidentiel et ne doit pas être reproduit ou utilisé sans le consentement de EXM

STANDARD FEATURES ARE NOT LISTED IN THIS HOLE TABLE

HOLE TABLE - TOP VIEW (CUSTOM FEATURE ONLY)

CUT-OUT	XDIM	YDIM	DESCRIPTION
1	15.000	20.000	Struts CR400 21.500" (Inside)
2	45.000	20.000	Struts CR400 21.500" (Inside)
3	15.000	20.929	STUDS M6 x 10mm (Inside)
4	25.866	20.000	STUDS M6 x 10mm (Inside)
5	45.000	20.929	STUDS M6 x 10mm (Inside)
6	55.866	20.000	STUDS M6 x 10mm (Inside)

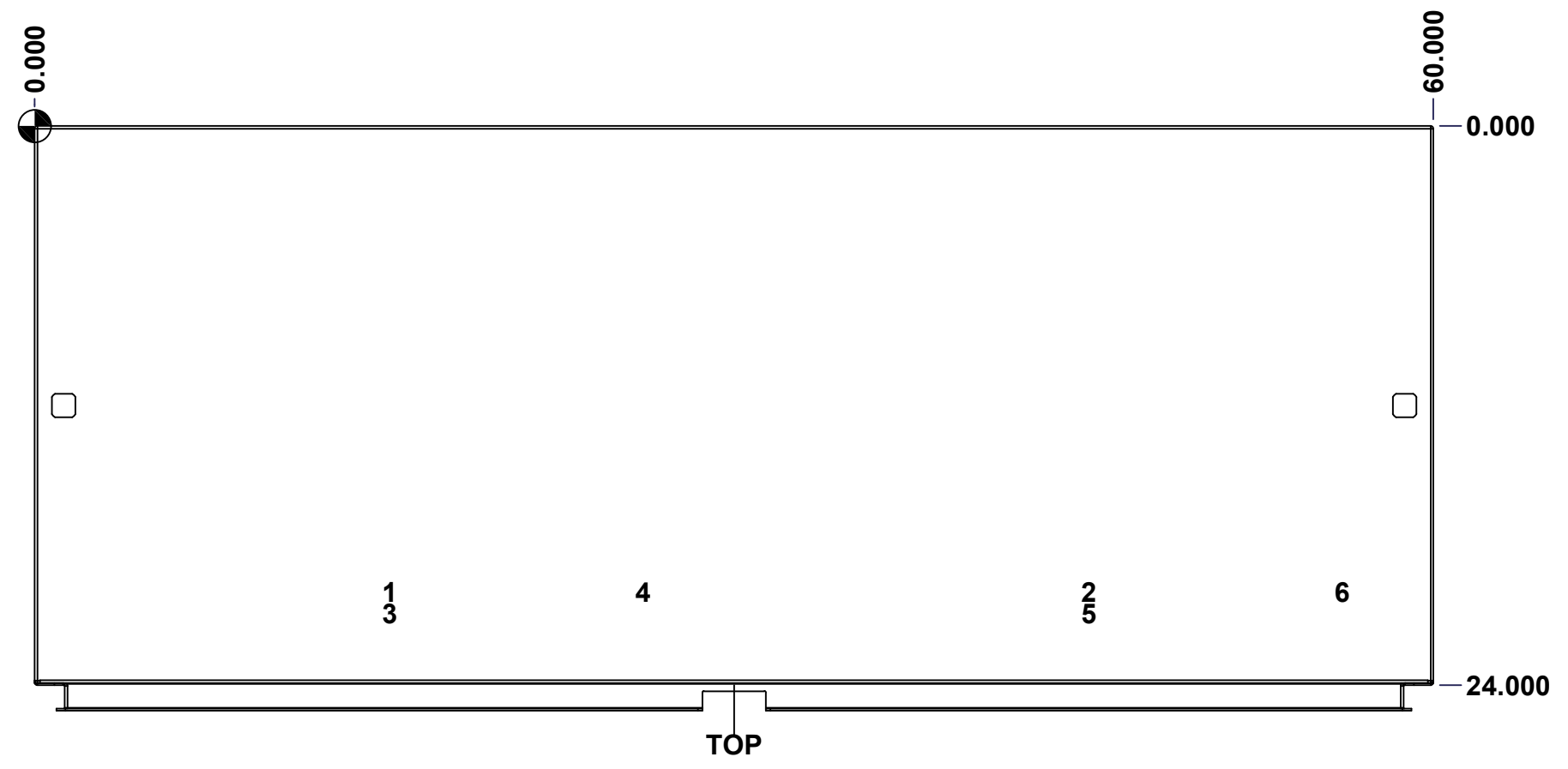

	Description	Status
	5412DDS 72" x 60" x 24" Body	(NULL)
	Part Number Numéro Pièce	Rev.
	5412DDH726024B	0 / 4
		18

This drawing is confidential and must not be reproduced or used without the consent of EXM

Ce dessin est confidentiel et ne doit pas être reproduit ou utilisé sans le consentement de EXM

STANDARD FEATURES ARE NOT LISTED IN THIS HOLE TABLE			
HOLE TABLE - RIGHT VIEW (CUSTOM FEATURE ONLY)			
CUT-OUT	XDIM	YDIM	DESCRIPTION
1	22.500	3.375	GND STUD M6 x 16mm (Inside)

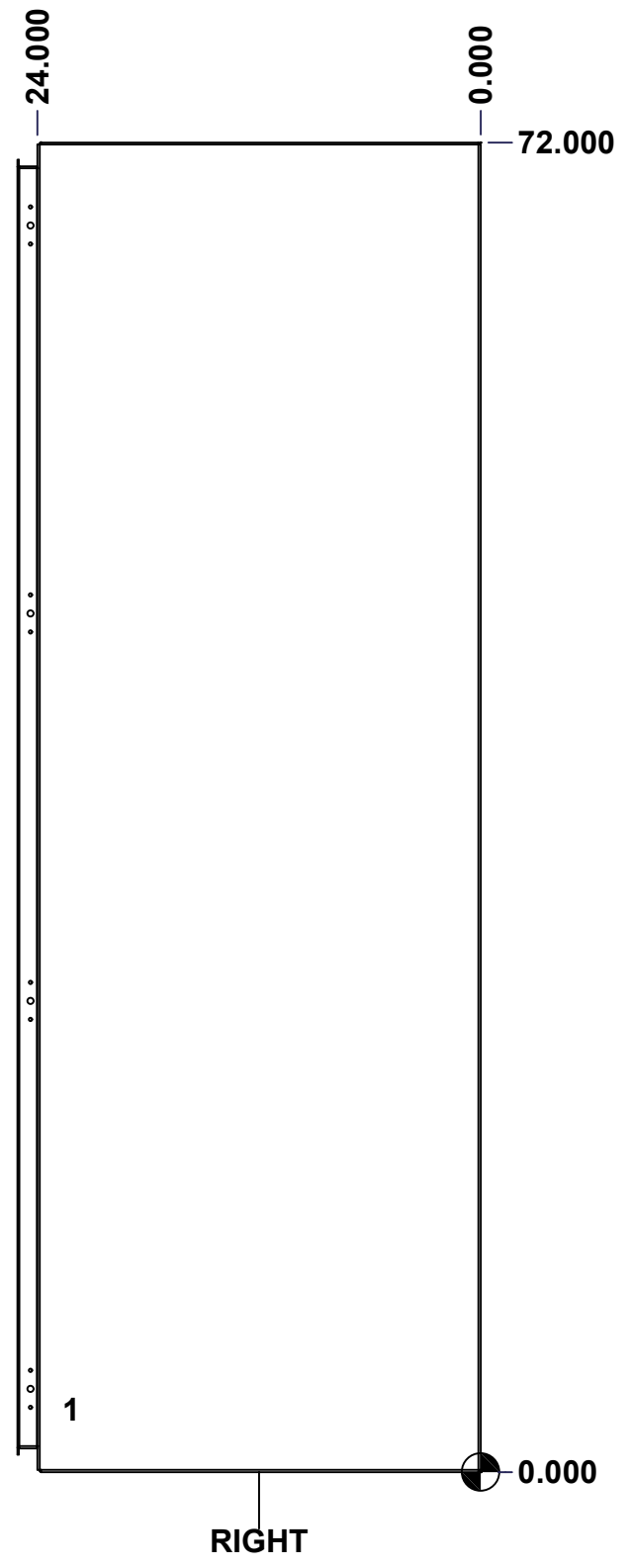

	Description	Status
	5412DDS 72" x 60" x 24" Body	(NULL)
Part Number Numéro Pièce 5412DDH726024B	Rev.	5
	0	18

This drawing is confidential and must not be reproduced or used without the consent of EXM

Ce dessin est confidentiel et ne doit pas être reproduit ou utilisé sans le consentement de EXM

STANDARD FEATURES ARE NOT LISTED IN THIS HOLE TABLE			
HOLE TABLE - LEFT VIEW (CUSTOM FEATURE ONLY)			
CUT-OUT	XDIM	YDIM	DESCRIPTION
1	22.500	3.375	GND STUD M6 x 16mm (Inside)

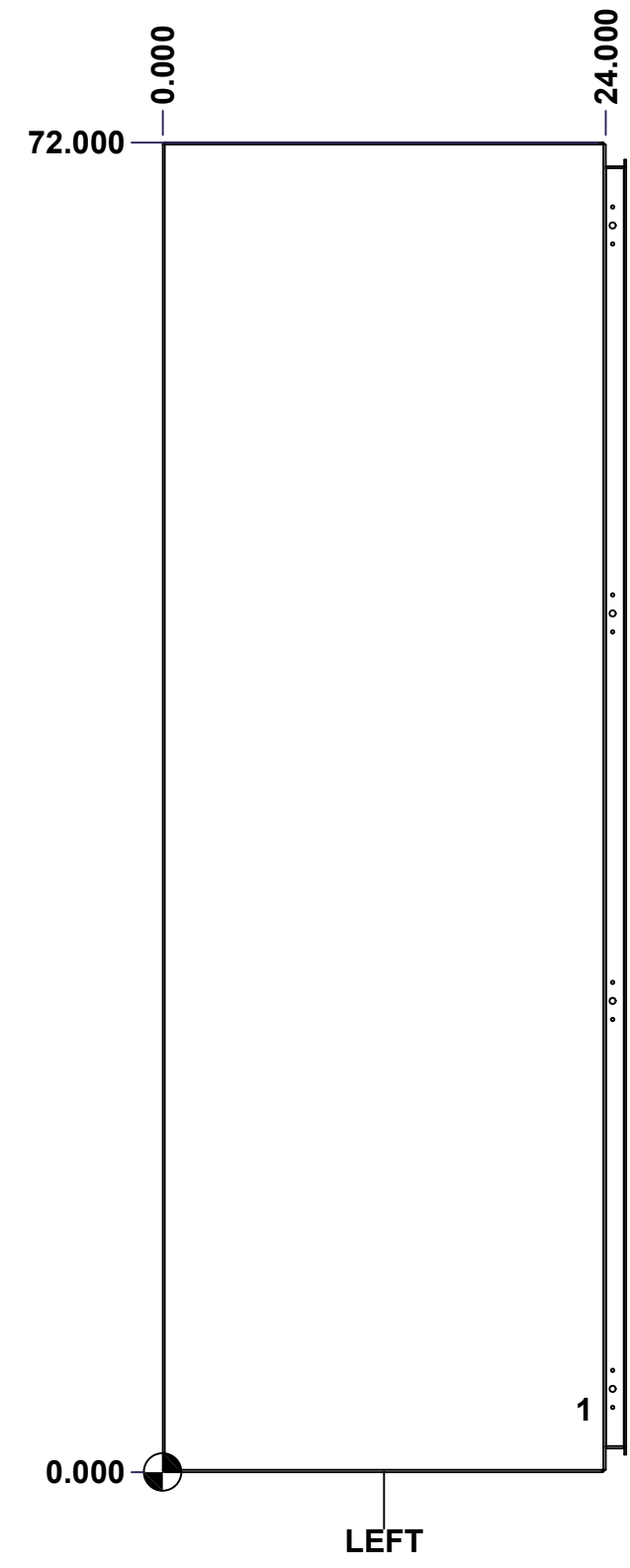

	Description	Status
	5412DDS 72" x 60" x 24" Body	(NULL)
	Part Number Numéro Pièce	Rev.
	5412DDH726024B	0 / 7
		18

This drawing is confidential and must not be reproduced or used without the consent of EXM

Ce dessin est confidentiel et ne doit pas être reproduit ou utilisé sans le consentement de EXM

STANDARD FEATURES ARE NOT LISTED IN THIS HOLE TABLE

HOLE TABLE - BACK VIEW (CUSTOM FEATURE ONLY)

CUT-OUT	XDIM	YDIM	DESCRIPTION
1	2.875	2.875	IP STUD M10 x 40mm (Inside)
2	57.125	2.875	IP STUD M10 x 40mm (Inside)
3	2.875	69.125	IP STUD M10 x 40mm (Inside)
4	57.125	69.125	IP STUD M10 x 40mm (Inside)
5	2.875	36.000	IP STUD M10 x 40mm (Inside)
6	57.125	36.000	IP STUD M10 x 40mm (Inside)
7	30.000	2.875	IP STUD M10 x 40mm (Inside)
8	30.000	69.125	IP STUD M10 x 40mm (Inside)

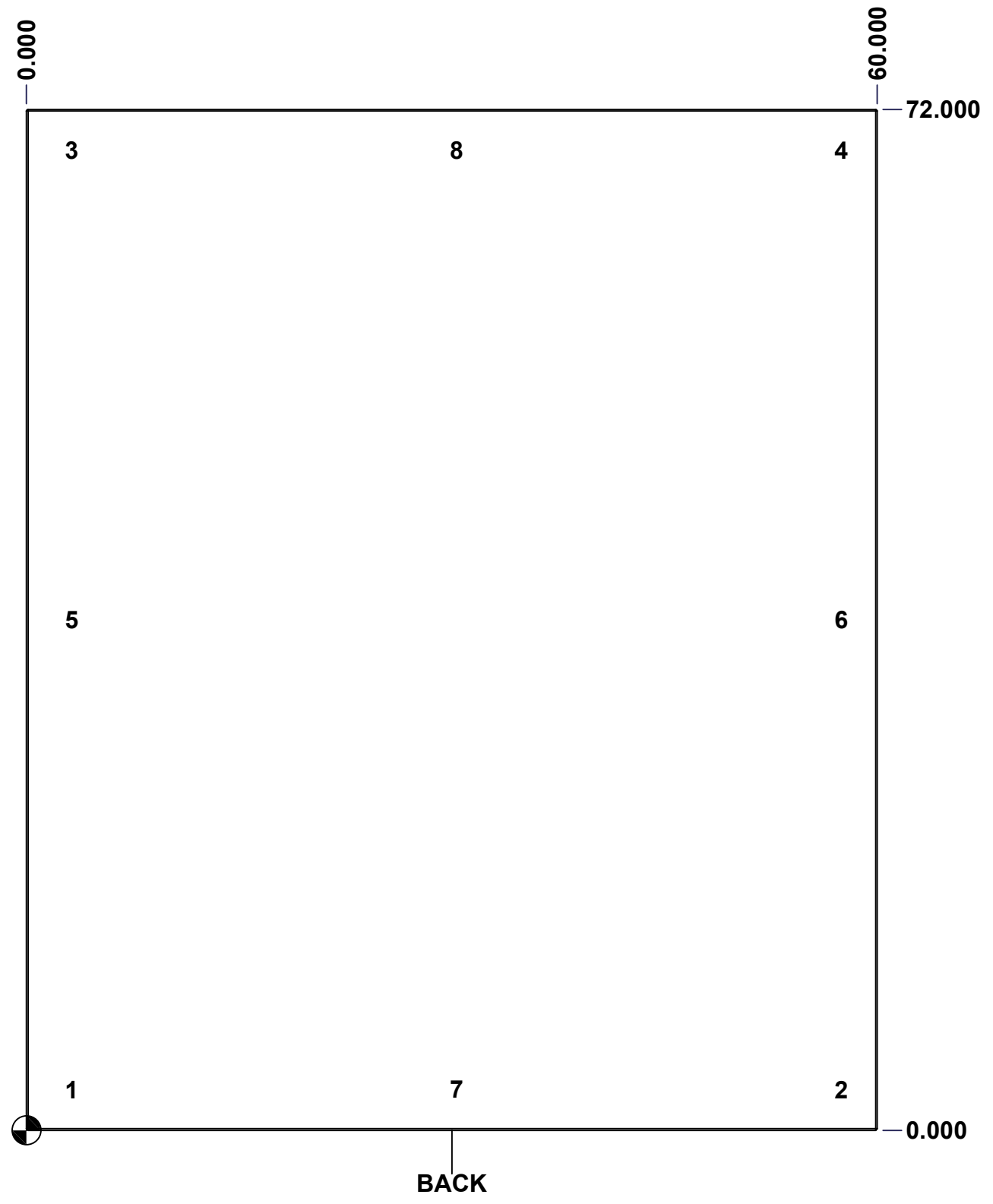

	Description	Status
	5412DDS 72" x 60" x 24" Body	(NULL)
	Part Number Numéro Pièce	Rev.
	5412DDH726024B	0 / 8
		18

This drawing is confidential and must not be reproduced or used without the consent of EXM

Ce dessin est confidentiel et ne doit pas être reproduit ou utilisé sans le consentement de EXM

STANDARD FEATURES ARE NOT LISTED IN THIS HOLE TABLE

HOLE TABLE - BACK VIEW (CUSTOM FEATURE ONLY)

CUT-OUT	XDIM	YDIM	DESCRIPTION
1	0.748	32.179	PEM FH-M6-15ZI (Inside)
2	0.748	34.305	PEM FH-M6-15ZI (Inside)
3	2.717	32.179	PEM FH-M6-15ZI (Inside)
4	2.717	34.305	PEM FH-M6-15ZI (Inside)

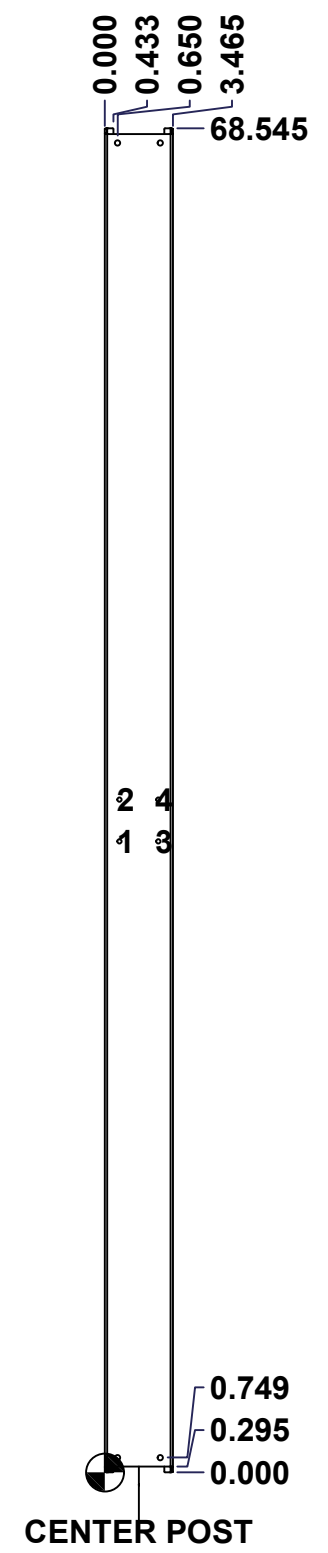

	Description	Status
	5412DDS 72" x 60" x 24" Body	(NULL)
	Part Number Numéro Pièce	Rev.
	5412DDH726024B	0 / 9
		18

This drawing is confidential and must not be reproduced or used without the consent of EXM

Ce dessin est confidentiel et ne doit pas être reproduit ou utilisé sans le consentement de EXM

No.	Revisions	Date	By/Par

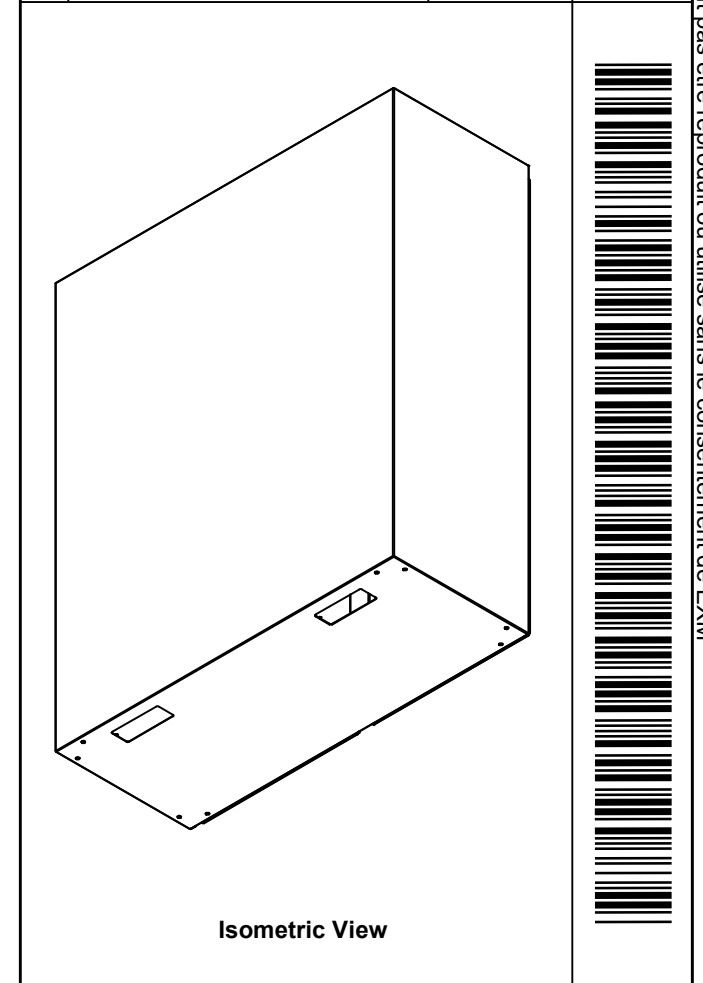

4	STK-PEM-FH-M6-15ZI	0	PEM Self-Clinching Stud M6 x 15.0mm
4	STK-Q-16030	0	Stud M6 x 10mm Steel
1	STK-P-02400S	0	Powder Paint (Asa-61 Grey / Smooth)
2	STK-Q-74910	0	Eyebolt Lifting Angle (15.500")
8	STK-Q-04056-12	0	M6 x 8mm Hexagon Socket Head Machine Screw with Nyseal
1	STK-K-75454	14	Center Post Freestanding Sealing Block with Latch Kit
1	5412DDH726024CP-P	0	5412DDS 72" Center Post Part
2	STK-Q-07320	0	Flange Lock Nut M10
2	STK-Q-07618	1	5500 Series Inner Panel Support Bracket
8	STK-Q-16100	0	Stud M10 x 40mm Steel
1	5412DDH726024B-P	0	5412DDS 72" x 60" Body Part
2	5412DDH726024_CR400 MS_21.5	0	Commercial Roll Mild Steel (21.5in long)
6	STK-Q-16080	0	Ground Stud M6 x 16mm Steel

Qty	Part Number	Rev	Description
Parts List			



Tél: (450) 979-4373
Fax: (450) 979-4626
www.exmweb.com

Flatness
Aplatissement
Max 3.0mm

Projection

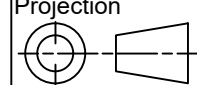

Customer Client	Date
Drawn By Dessiné Par BoxCad: BoxCad	Date 25-Jul-24
Material Matière 12 Ga Cold Rolled A1008 CS Type B (2.5mm)	
Color Couleur Asa-61 Grey	Finish Fini Smooth
Description 5412DDS 72" x 60" x 24" Body	Detail Rev.
Part Number Numéro Pièce 5412DDH726024B	Rev. 10 0 18

This drawing is confidential and must not be reproduced or used without the consent of EXM

Ce dessin est confidentiel et ne doit pas être reproduit ou utilisé sans le consentement de EXM

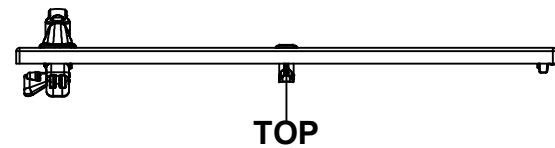

TOP

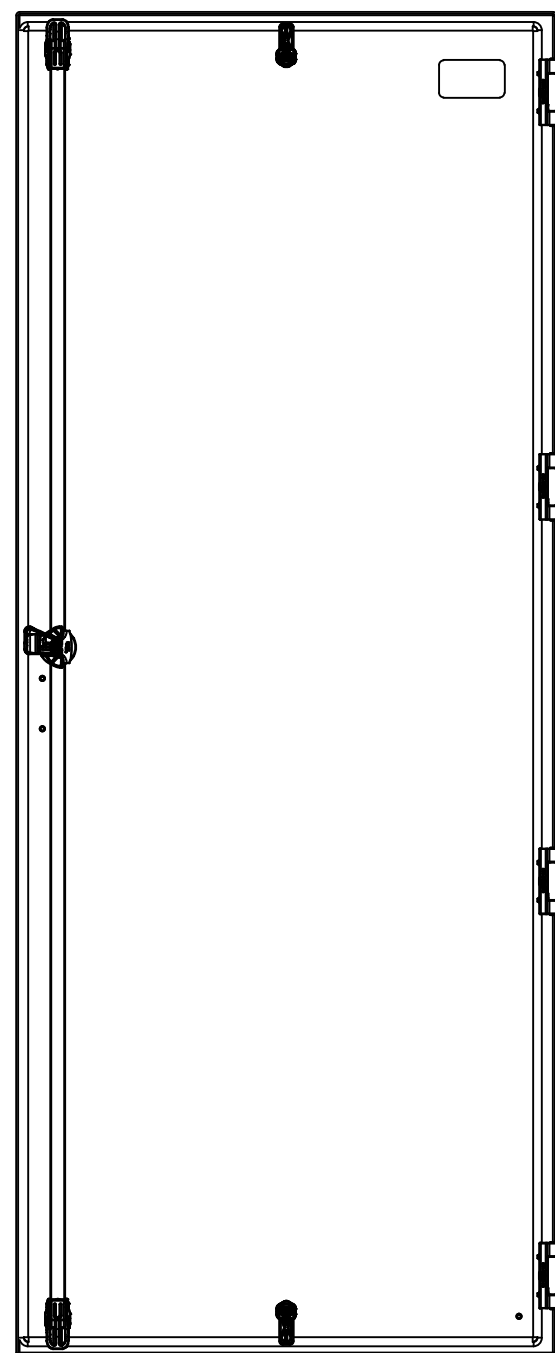

BACK

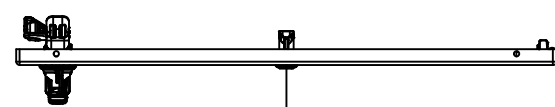

BOTTOM

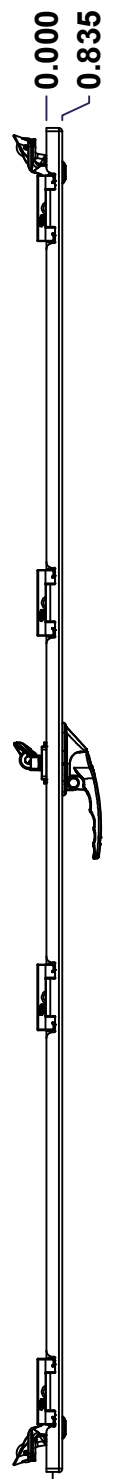

LEFT

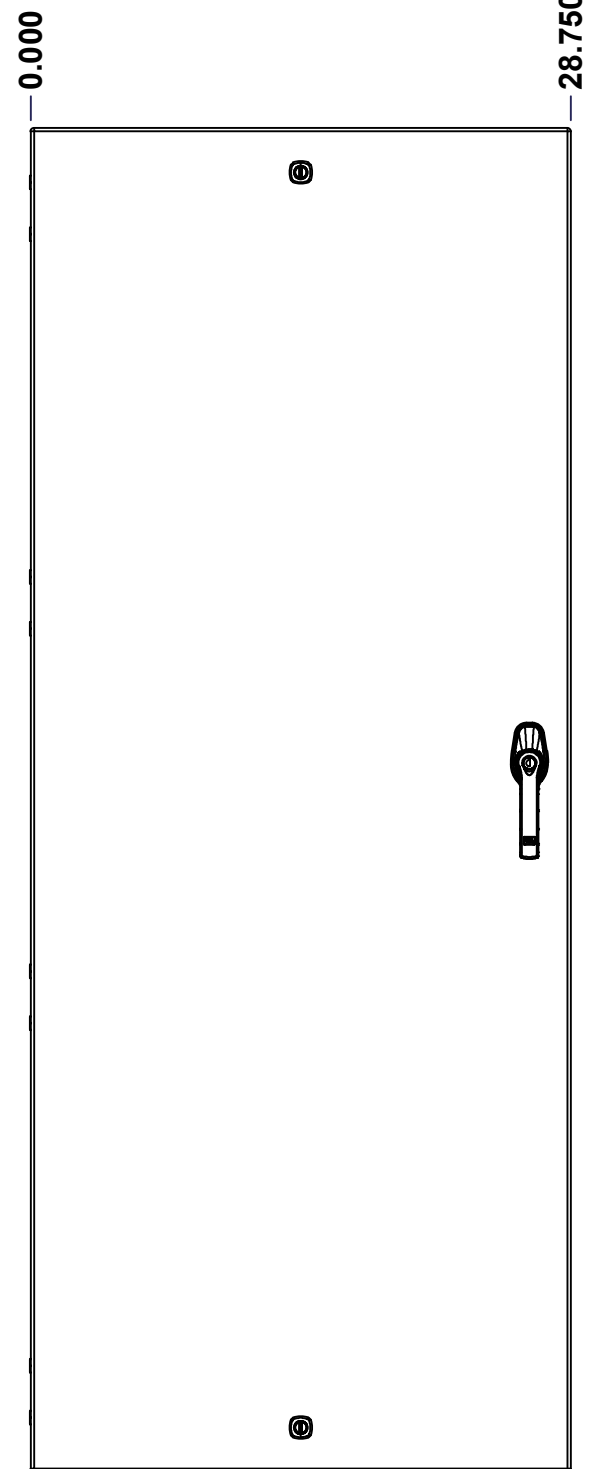

FRONT

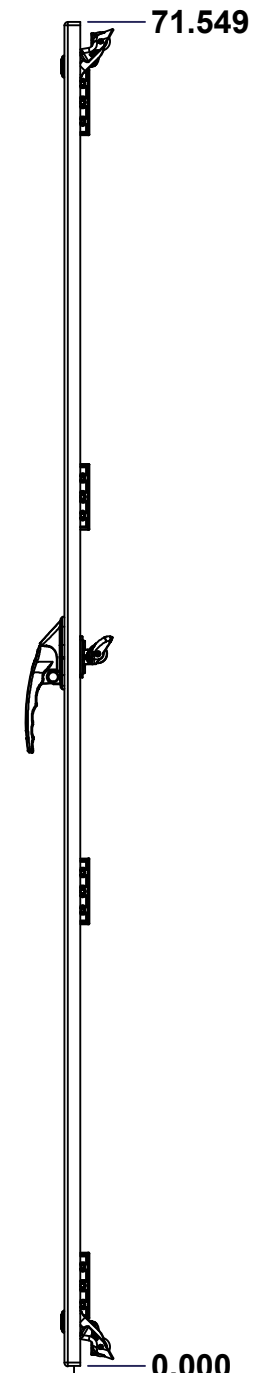

RIGHT

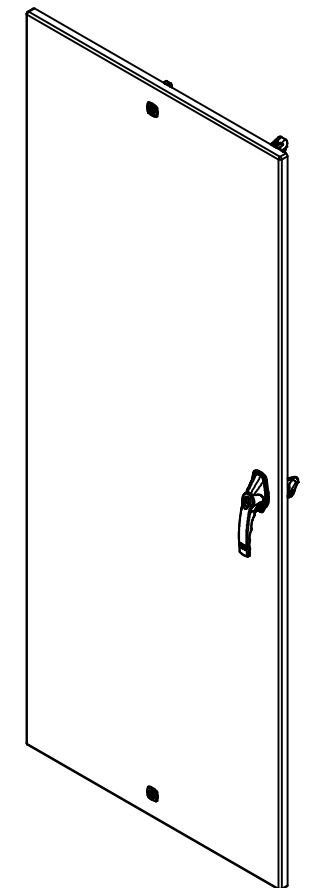

Isometric View

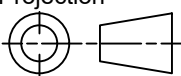

No.	Revisions	Date	By/Par

 Tél: (450) 979-4373 Fax: (450) 979-4626 www.exmweb.com		Flatness Aplatissement Max 3.0mm Projection 
Customer Client	Date	
Drawn By Dessiné Par	BoxCad: BoxCad	Date 25-Jul-24
Material Matière	12 Ga Cold Rolled A1008 CS Type B (2.5mm)	
Color Couleur	Asa-61 Grey	Finish Fini Smooth
Description		Detail Rev.
5412DDS 72" x 60" Slave Door		
Part Number Numéro Pièce	Rev. 11	18
SEE BILL OF MATERIAL ON LAST PAGE		0
5412DDH726024LD		

This drawing is confidential and must not be reproduced or used without the consent of EXM

Ce dessin est confidentiel et ne doit pas être reproduit ou utilisé sans le consentement de EXM

STANDARD FEATURES ARE NOT LISTED IN THIS HOLE TABLE

HOLE TABLE - FRONT VIEW (CUSTOM FEATURE ONLY)

CUT-OUT	XDIM	YDIM	DESCRIPTION
1	26.546	6.118	LARGE CBAR GUIDE (Inside)
2	26.546	65.431	LARGE CBAR GUIDE (Inside)

3	2.000	2.118	GND STUD M6 x 16mm (Inside)
4	14.375	2.368	LOCK 889 SCQ4-SL @ 270.0°
5	14.375	69.180	LOCK 889 SCQ4-SL @ 90.0°
6	26.546	37.743	HANDLE 885 ESL2A-APHK @ 0.0°
7	27.372	33.404	STUDS M6 x 18mm (Inside)
8	27.372	36.082	STUDS M6 x 18mm (Inside)

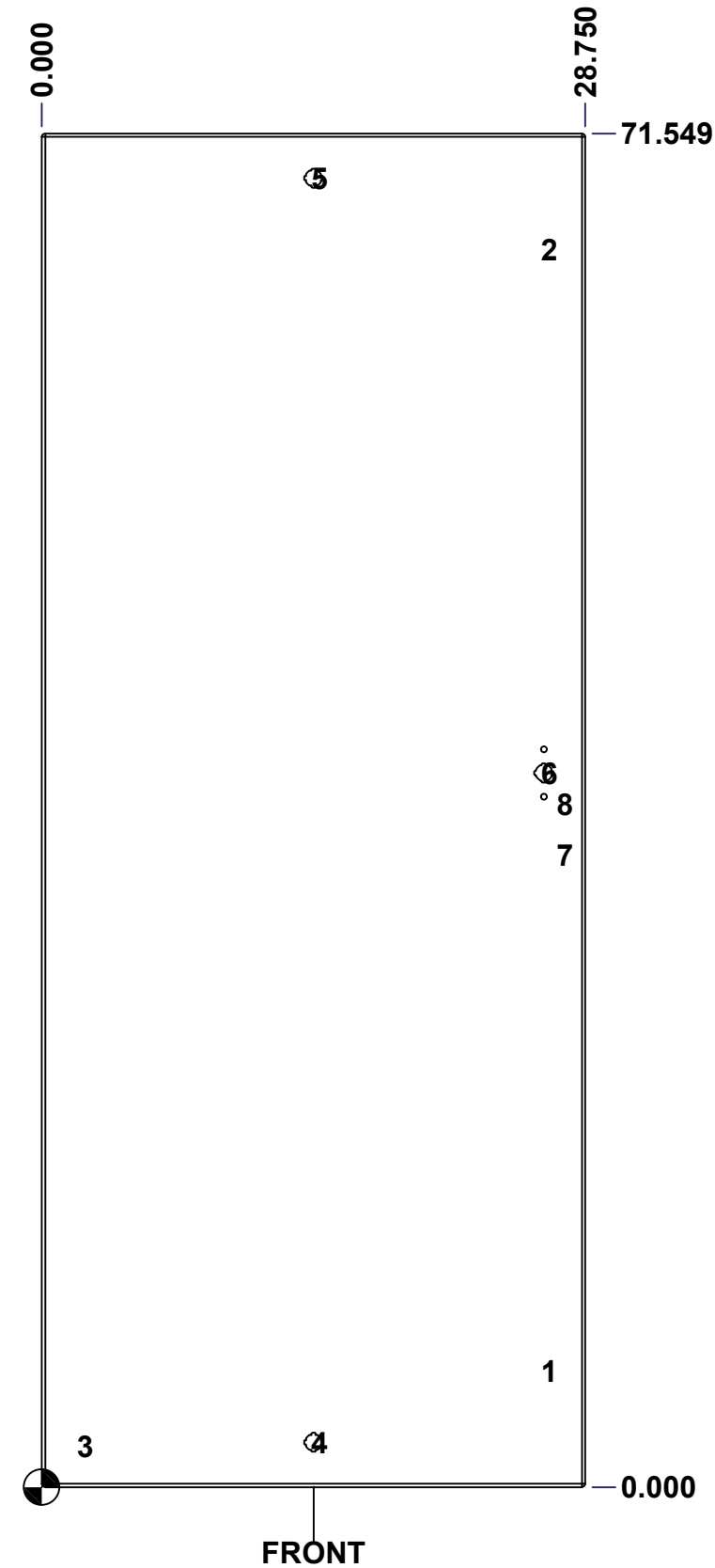

FRONT

	Description	Status
	5412DDS 72" x 60" Slave Door	(NULL)
	Part Number Numéro Pièce	Rev.
	5412DDH726024LD	0
		12
		18

This drawing is confidential and must not be reproduced or used without the consent of EXM

Ce dessin est confidentiel et ne doit pas être reproduit ou utilisé sans le consentement de EXM

No.	Revisions	Date	By/Par

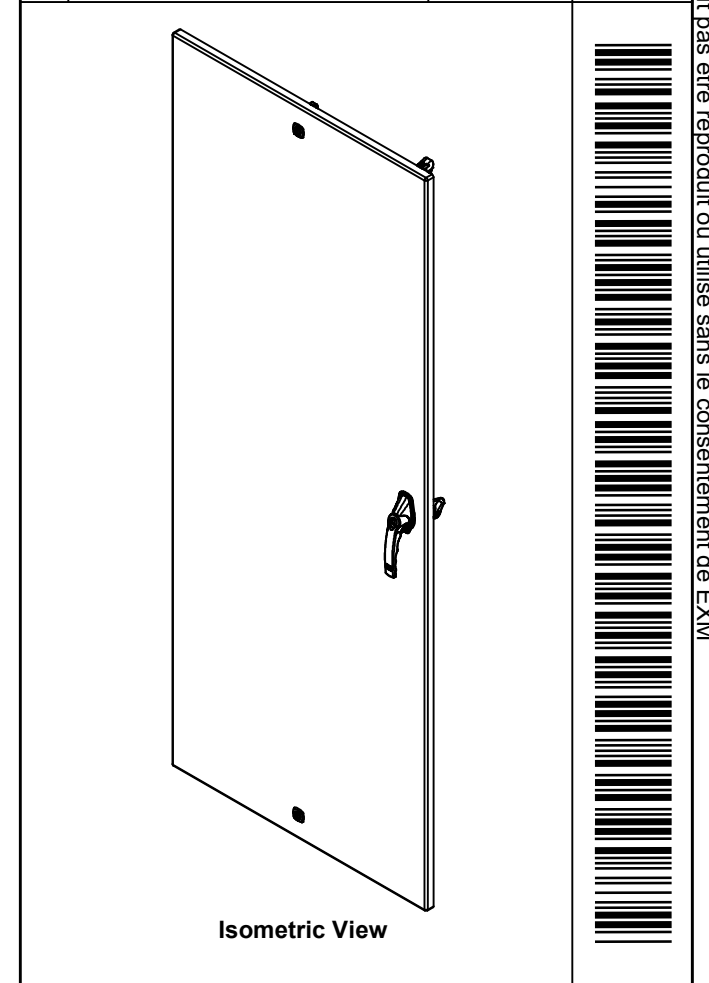

2	STK-Q-16050	1	Stud M6 x 18mm Steel
2	STK-Q-07220	1	M6 Nylon Insert Lock Nut
1	STK-Q-47542	1	5500 DDS Lower Closing Bar 72"
2	STK-A-90025	3	9500 - Cabinet Closing Bar End (Large)
1	STK-Q-47532	0	5500 DDS Upper Closing Bar 72"
1	STK-A-50538	3	9500 Handle Cam Assembly (Right Side, Grip 36mm)
1	STK-Q-90051	3	5412 ES - Handle Cam Spacer
1	885ESL2A-APHK	7	885 ESL2A-APHK - Zinc Die Cast L-Handle Padlockable Assy
2	STK-K-12580	0	9412 1/4 Turn Lock
1	STK-Q-16080	0	Ground Stud M6 x 16mm Steel
1	STK-P-02400S	0	Powder Paint (Asa-61 Grey / Smooth)
1	STK-S-00100	0	3.5" x 2" Silver Milar Flexcon Sticker
2	STK-Q-16410	0	Guide Stud - Largel (No Paint Cap Required)
4	STK-K-09860	7	Cabinet Hinge with Captive Pins
1	5412DDH726024DG	0	5412DDS 72" x 60" Door Gasket
1	5412DDH726024LD-P	0	5412DDS 72" x 60" Slave Door Part

QTY	Part Number	Rev	Description
Parts List			

Tél: (450) 979-4373 Fax: (450) 979-4626 www.exmweb.com	Flatness Aplatissement	Max 3.0mm
	Projection	
Customer Client	Date	
Drawn By Dessiné Par	BoxCad: BoxCad	Date 25-Jul-24
Material Matière	12 Ga Cold Rolled A1008 CS Type B (2.5mm)	
Color Couleur	Asa-61 Grey	Finish Fini Smooth
Description	Detail Rev.	
5412DDS 72" x 60" Slave Door		
Part Number Numéro Pièce	Rev. 0	13 18
5412DDH726024LD		

This drawing is confidential and must not be reproduced or used without the consent of EXM

Ce dessin est confidentiel et ne doit pas être reproduit ou utilisé sans le consentement de EXM

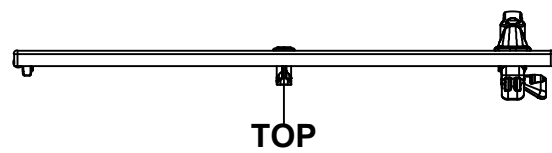

TOP

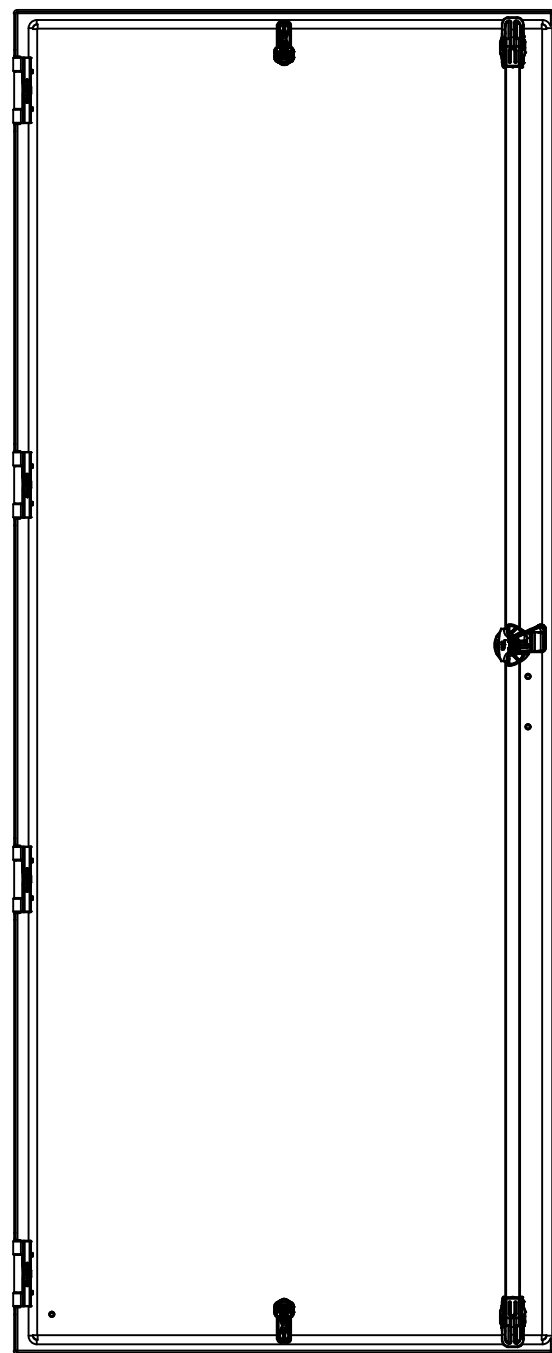

BACK

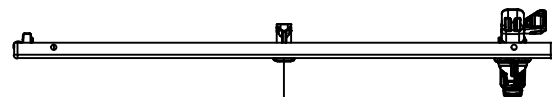

BOTTOM

0.000
0.835

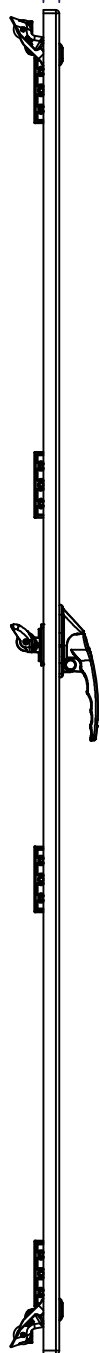

LEFT

28.750

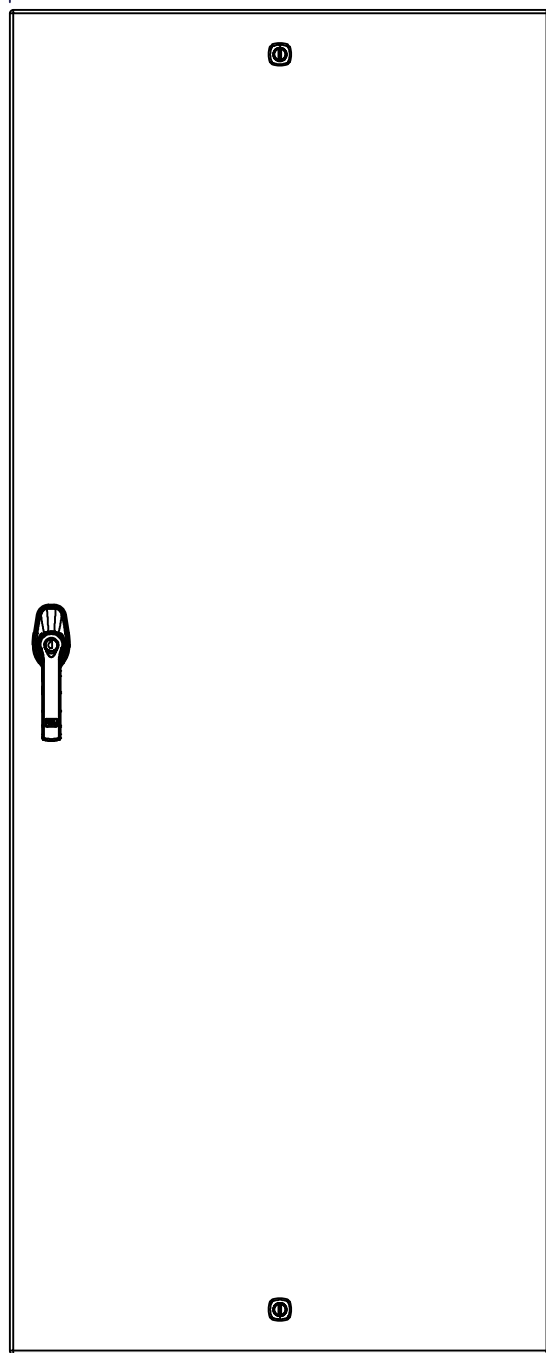

FRONT

0.000

71.549

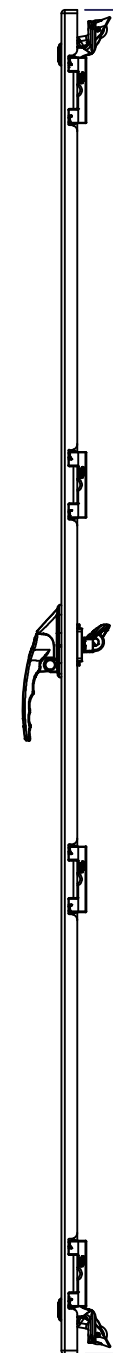

RIGHT

0.000

No.	Revisions	Date	By/Par

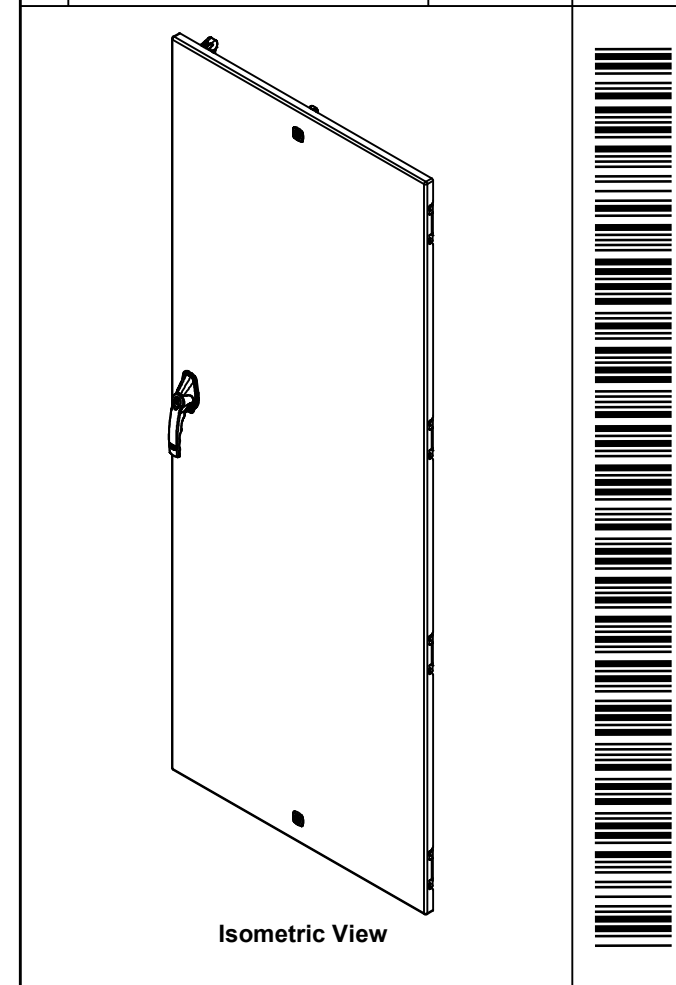

EXM
exm

Tél: (450) 979-4373
Fax: (450) 979-4626
www.exmweb.com

Flatness
Aplatissement
Max 3.0mm

Projection

Customer Client	Date
Drawn By Dessiné Par BoxCad: BoxCad	Date 25-Jul-24

Material Matière	12 Ga Cold Rolled A1008 CS Type B (2.5mm)
---------------------	---

Color Couleur	Asa-61 Grey	Finish Fini	Smooth
------------------	-------------	----------------	--------

Description	Detail Rev.
5412DDS 72" x 60" Master Door	

Part Number Numéro Pièce	Rev.	14
5412DDH726024FD	0	18

SEE BILL OF MATERIAL ON LAST PAGE

This drawing is confidential and must not be reproduced or used without the consent of EXM

Ce dessin est confidentiel et ne doit pas être reproduit ou utilisé sans le consentement de EXM

STANDARD FEATURES ARE NOT LISTED IN THIS HOLE TABLE

HOLE TABLE - FRONT VIEW (CUSTOM FEATURE ONLY)

CUT-OUT	XDIM	YDIM	DESCRIPTION
1	26.546	6.118	LARGE CBAR GUIDE (Inside)
2	26.546	65.431	LARGE CBAR GUIDE (Inside)

3	2.000	2.118	GND STUD M6 x 16mm (Inside)
4	14.375	2.368	LOCK 889 SCQ4-SL @ 270.0°
5	14.375	69.180	LOCK 889 SCQ4-SL @ 90.0°
6	26.546	37.743	HANDLE 885 ESL2A-APHK @ 0.0°
7	27.372	33.404	STUDS M6 x 18mm (Inside)
8	27.372	36.082	STUDS M6 x 18mm (Inside)

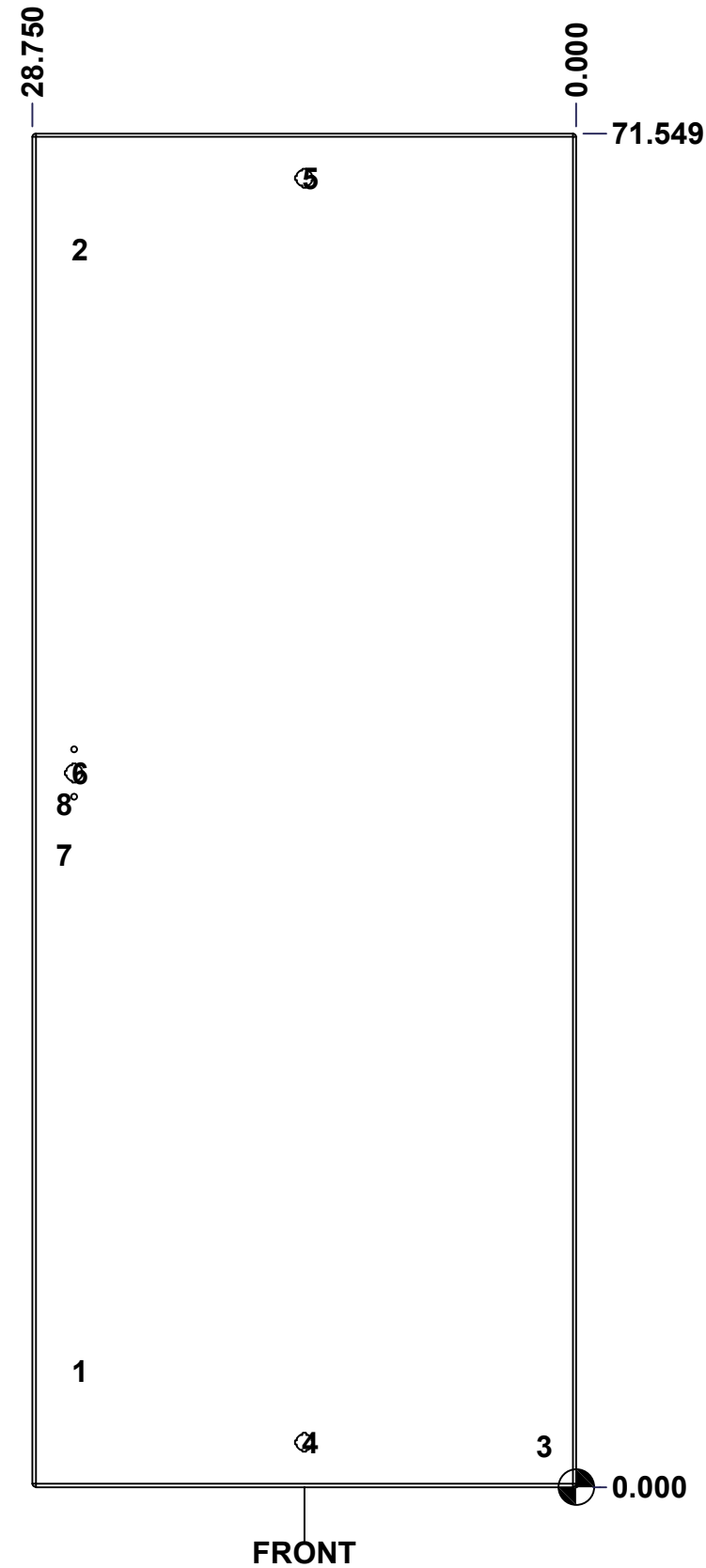

FRONT

	Description	Status
	5412DDS 72" x 60" Master Door	(NULL)
	Part Number Numéro Pièce	Rev.
	5412DDH726024FD	0
		15
		18

This drawing is confidential and must not be reproduced or used without the consent of EXM

Ce dessin est confidentiel et ne doit pas être reproduit ou utilisé sans le consentement de EXM

No.	Revisions	Date	By/Par

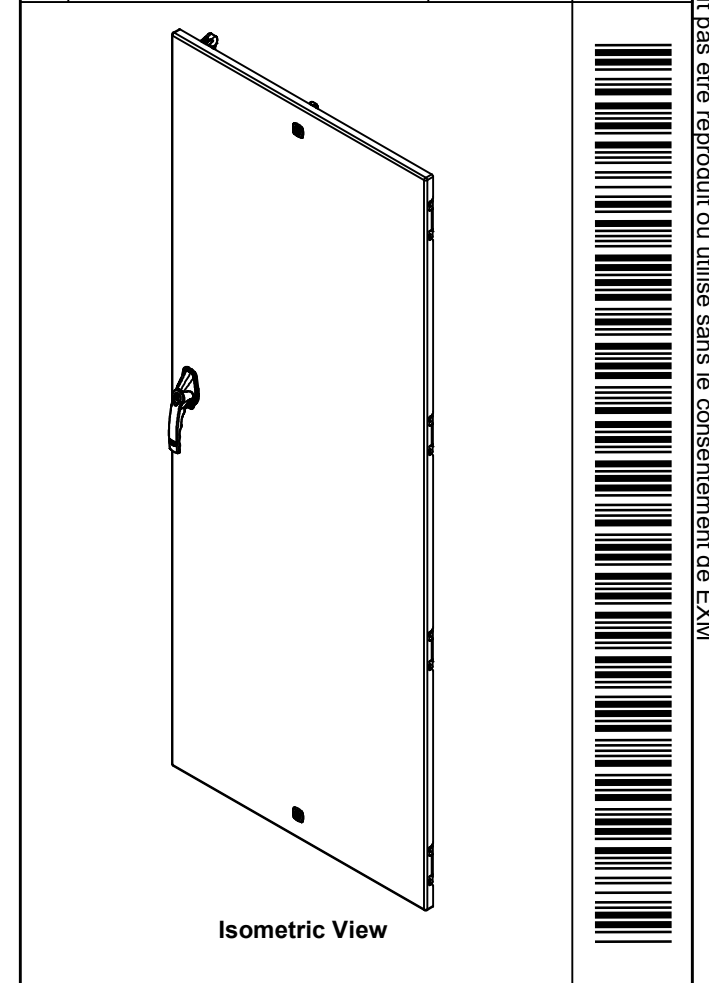

2	STK-Q-16050	1	Stud M6 x 18mm Steel
2	STK-Q-07220	1	M6 Nylon Insert Lock Nut
1	STK-Q-47542	1	5500 DDS Lower Closing Bar 72"
2	STK-A-90025	3	9500 - Cabinet Closing Bar End (Large)
1	STK-Q-47532	0	5500 DDS Upper Closing Bar 72"
1	STK-A-50537	3	9500 Handle Cam Assembly (Left Side, Grip 36mm)
1	STK-Q-90051	3	5412 ES - Handle Cam Spacer
1	885ESL2A-APHK	7	885 ESL2A-APHK - Zinc Die Cast L-Handle Padlockable Assy
2	STK-K-12580	0	9412 1/4 Turn Lock
1	STK-Q-16080	0	Ground Stud M6 x 16mm Steel
1	STK-P-02400S	0	Powder Paint (Asa-61 Grey / Smooth)
2	STK-Q-16410	0	Guide Stud - Largel (No Paint Cap Required)
4	STK-K-09860	7	Cabinet Hinge with Captive Pins
1	5412DDH726024DG	0	5412DDS 72" x 60" Door Gasket
1	5412DDH726024FD-P	0	5412DDS 72" x 60" Master Door Part

QTY	Part Number	Rev	Description
Parts List			

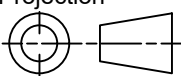
 Tél: (450) 979-4373 Fax: (450) 979-4626 www.exmweb.com		Flatness Aplatissement Max 3.0mm
Projection 		Date 25-Jul-24
Customer Client	BoxCad: BoxCad	Date
Drawn By Dessiné Par	BoxCad: BoxCad	Date
Material Matière	12 Ga Cold Rolled A1008 CS Type B (2.5mm)	
Color Couleur	Asa-61 Grey	Finish Fini Smooth
Description		Detail Rev.
5412DDS 72" x 60" Master Door		
Part Number Numéro Pièce	5412DDH726024FD	Rev. 16 0 18

This drawing is confidential and must not be reproduced or used without the consent of EXM

Ce dessin est confidentiel et ne doit pas être reproduit ou utilisé sans le consentement de EXM

No.	Revisions	Date	By/Par

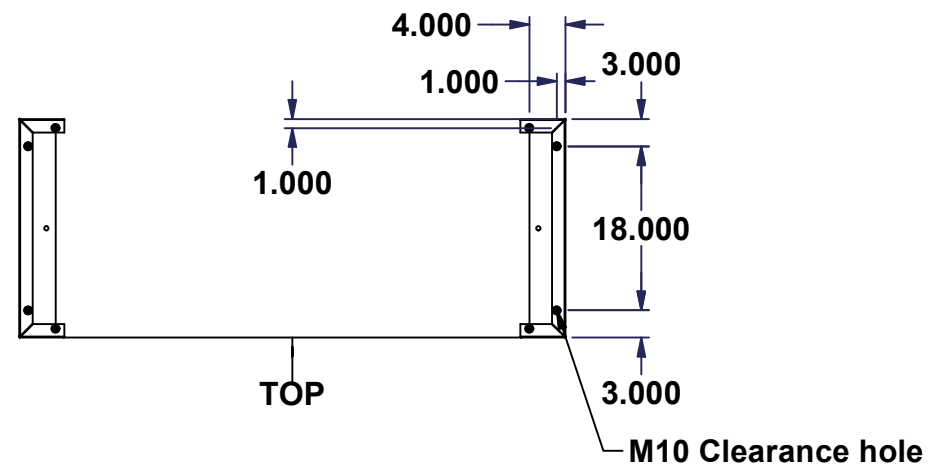

ENCLOSURE CUTOUT LAYOUT

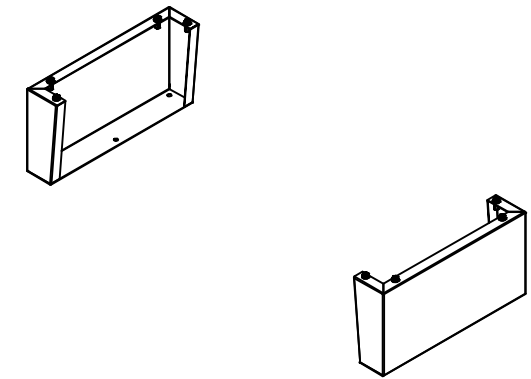
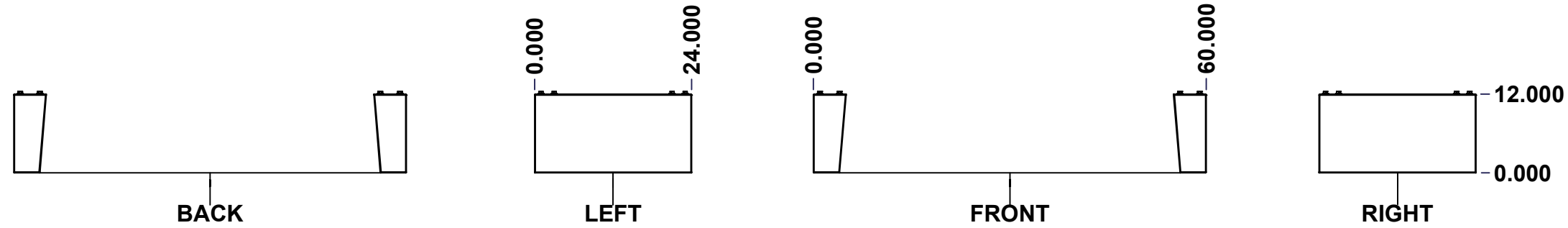

Isometric View

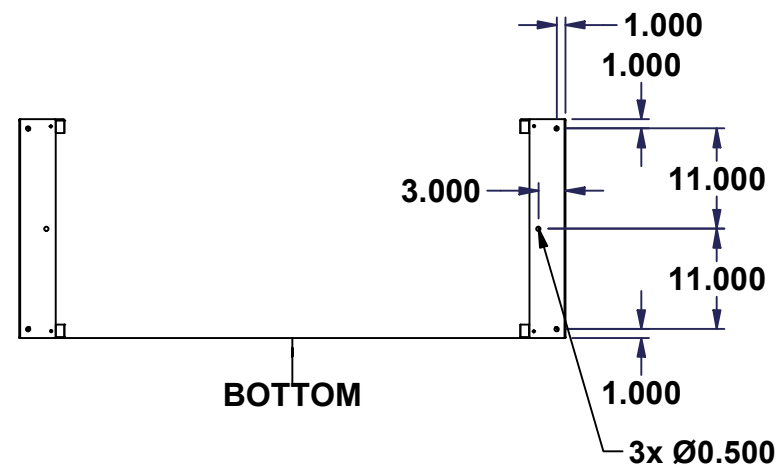

FLOOR ANCHORAGE LAYOUT

EXM
 Tél: (450) 979-4373
 Fax: (450) 979-4626
www.exmweb.com

Flatness
 Aplatissement
 Max 3.0mm
 Projection

Customer Client	Date
Drawn By Dessiné Par BoxCad: BoxCad	Date 25-Jul-24
Material Matière 12 Ga Cold Rolled A1008 CS Type B (2.5mm)	
Color Couleur Asa-61 Grey	Finish Fini Smooth
Description 885 MFHD 12" x 24" Mounting Feet	Detail Rev.

Part Number Numéro Pièce	Rev.	17
885MFHD1224	0	18

SEE BILL OF MATERIAL ON LAST PAGE

This drawing is confidential and must not be reproduced or used without the consent of EXM

Ce dessin est confidentiel et ne doit pas être reproduit ou utilisé sans le consentement de EXM

No.	Revisions	Date	By/Par

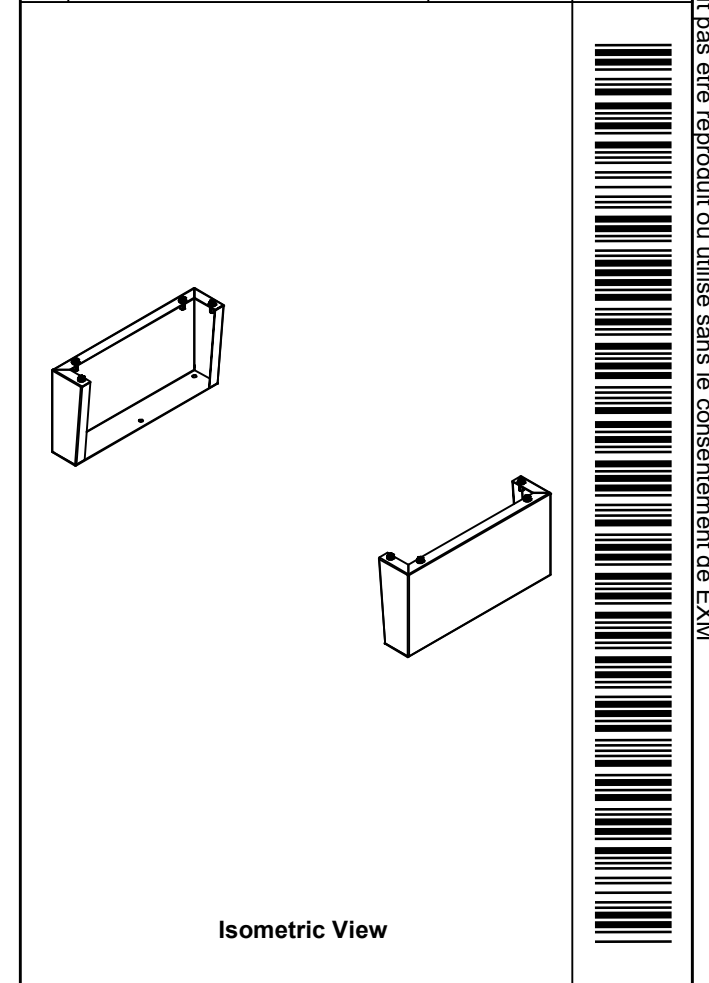

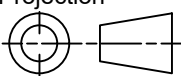
 Tél: (450) 979-4373 Fax: (450) 979-4626 www.exmweb.com		Flatness Aplatissement Max 3.0mm Projection 
Customer Client	Date	
Drawn By Dessiné Par	BoxCad: BoxCad	Date 25-Jul-24
Material Matière	12 Ga Cold Rolled A1008 CS Type B (2.5mm)	
Color Couleur	Asa-61 Grey	Finish Fini Smooth
Description		Detail Rev.
885 MFHD 12" x 24" Mounting Feet		
Part Number Numéro Pièce	885MFHD1224	Rev. 18
		0 18

Qty	Part Name	Rev	Description
1	STK-P-02400S	0	Powder Paint (Asa-61 Grey / Smooth)
8	RIVET_NUT_M10_FH_CE	0	Rivet Nut M10 (Low Profile Close End)
1	5412DDH726024MFR-P	0	885 MFHD 12" x 24" Right Mounting Feet Part
1	5412DDH726024MFL-P	0	885 MFHD 12" x 24" Left Mounting Feet Part
4	STK-K-11600	2	885 MF Accessory Kit
Parts List			

This drawing is confidential and must not be reproduced or used without the consent of EXM

Ce dessin est confidentiel et ne doit pas être reproduit ou utilisé sans le consentement de EXM

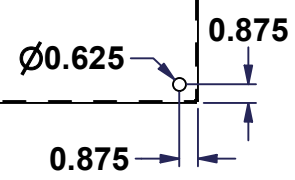
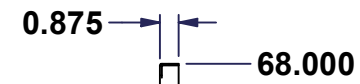
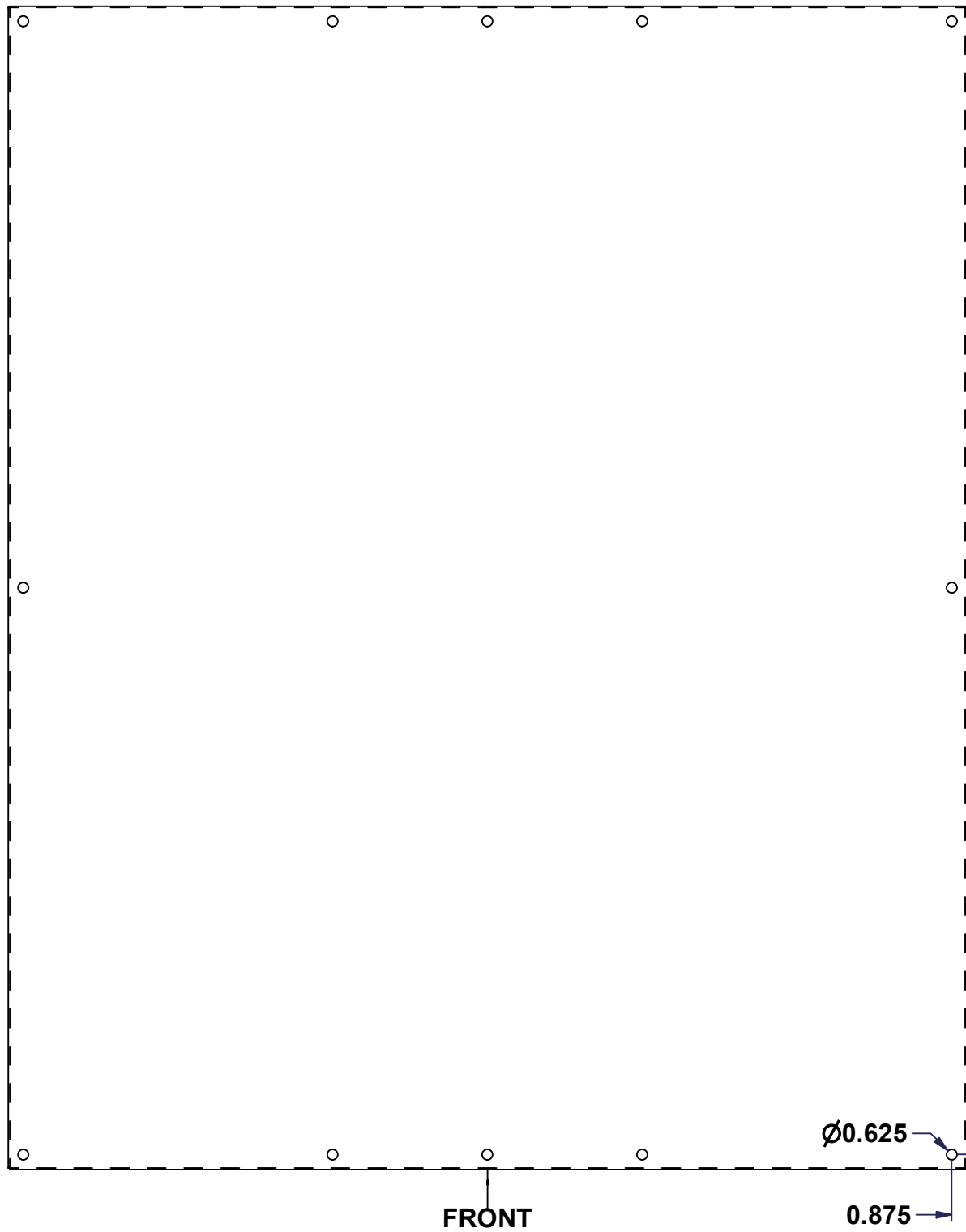
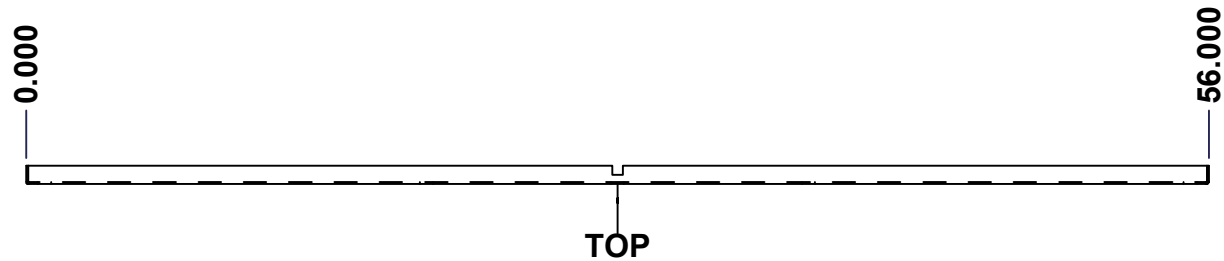

No.	Revisions	Date	By/Par

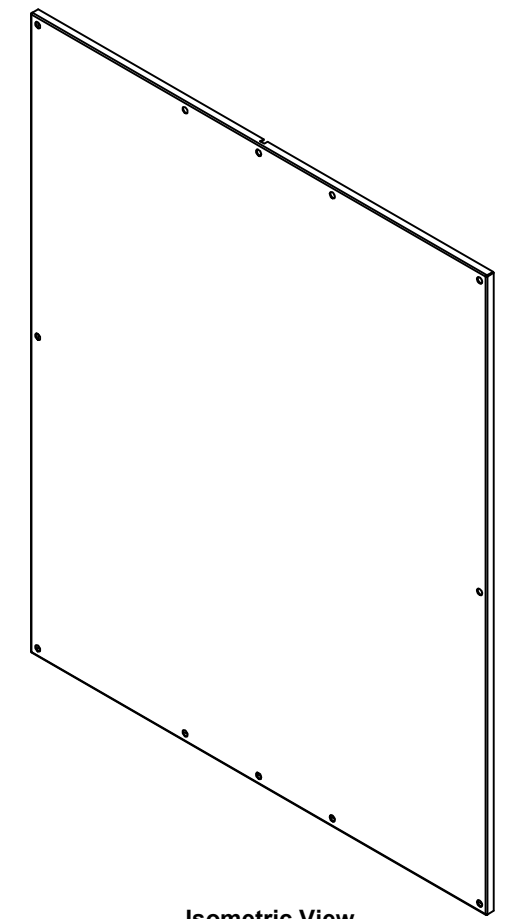

Isometric View



Tél: (450) 979-4373
 Fax: (450) 979-4626
 www.exmweb.com

Flatness
 Aplatissement
 Max 3.0mm
 Projection

Customer Client	Date
Drawn By / Dessiné Par: BoxCad	Date: 04/11/2009

Material / Matière: 12 Ga Galvanized (2.5mm)

Color / Couleur: Unpainted	Finish / Fini: Unpainted
----------------------------	--------------------------

Description: 885 SP7260G Inner Panel

Part Number / Numéro Pièce: 885SP7260G	Rev. 1
	2

SEE BILL OF MATERIAL ON LAST PAGE

This drawing is confidential and must not be reproduced or used without the consent of EXM

Ce dessin est confidentiel et ne doit pas être reproduit ou utilisé sans le consentement de EXM

No.	Revisions	Date	By/Par

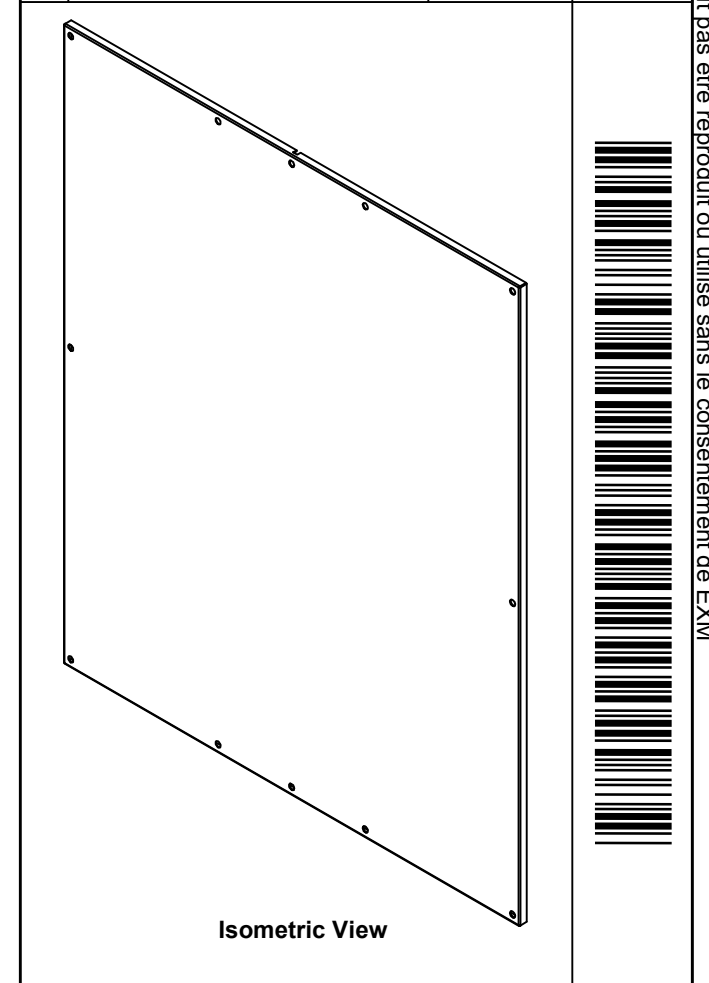

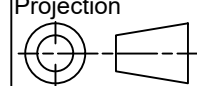
 Tél: (450) 979-4373 Fax: (450) 979-4626 www.exmweb.com		Flatness Aplatissement Max 3.0mm
Customer Client		Projection 
Drawn By / Dessiné Par: BoxCad		Date: 04/11/2009
Material / Matière: 12 Ga Galvanized (2.5mm)		
Color / Couleur: Unpainted	Finish / Fini: Unpainted	
Description: 885 SP7260G Inner Panel		Detail Rev.
Part Number / Numéro Pièce: 885SP7260G		Rev. 0 / 2

Qty	Part Number	Rev	Description
1	885SP7260G-P	0	885 SP7260G Inner Panel Part
Parts List			