

This drawing is confidential and must not be reproduced or used without the consent of EXM

Ce dessin est confidentiel et ne doit pas être reproduit ou utilisé sans le consentement de EXM

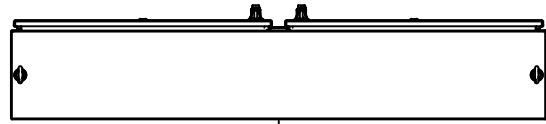

TOP

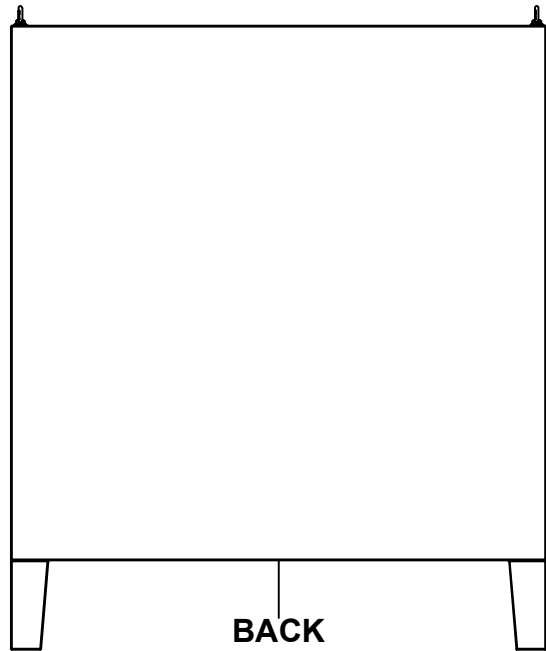

BACK

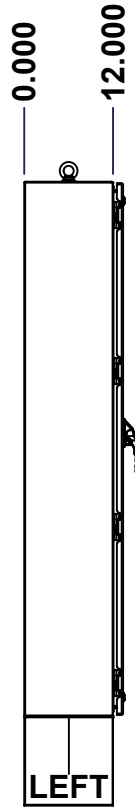

LEFT

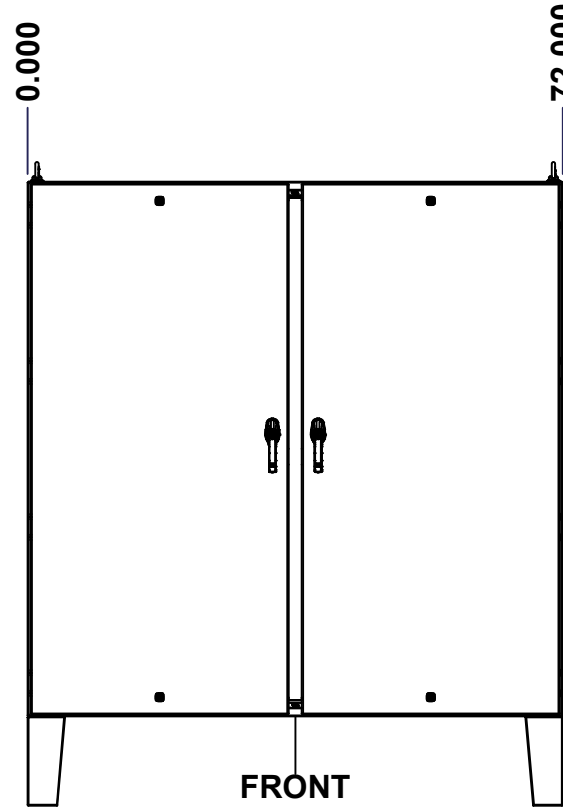

FRONT

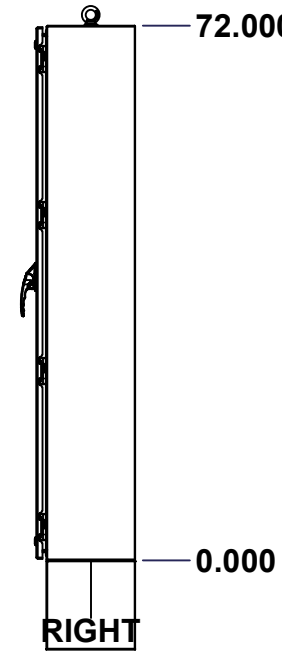

RIGHT

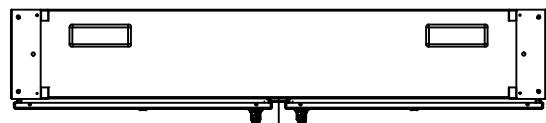

BOTTOM

No.	Revisions	Date	By/Par

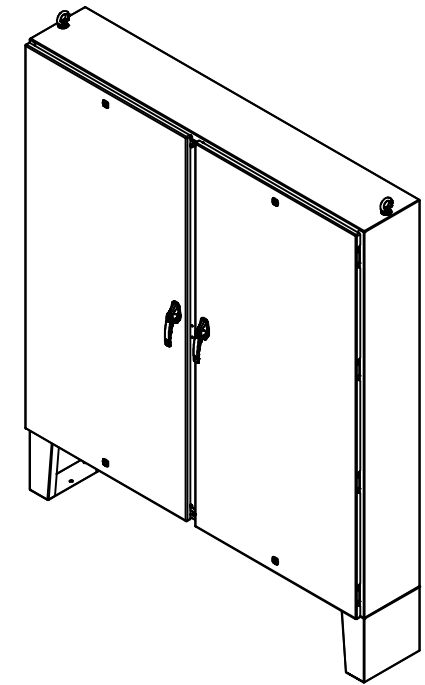

Isometric View



Tél: (450) 979-4373
 Fax: (450) 979-4626
www.exmweb.com

Flatness
Aplatissement

Max 3.0mm

Projection



Customer Client	Date
Drawn By Dessiné Par BoxCad: BoxCad	Date 21-Jan-26
Material Matière 12 Ga Cold Rolled A1008 CS Type B (2.5mm)	
Color Couleur Asa-61 Grey	Finish Fini Smooth
Description 5412DDS 72" x 72" x 12" Assembly	Detail Rev.
Part Number Numéro Pièce 5412DDH727212	Rev. 0

SEE BILL OF MATERIAL ON LAST PAGE

This drawing is confidential and must not be reproduced or used without the consent of EXM

Ce dessin est confidentiel et ne doit pas être reproduit ou utilisé sans le consentement de EXM

NOTE	
ITEM	DESCRIPTION
1	NEMA 4, 12 Enclosure (IP66)
2	C/W Standard ground studs on box and cover
3	W/O Standard door stiffener
4	C/W Standard inner panel (Included)
5	C/W Standard inner panel mounting studs
6	C/W Eyebolts sold separately (Installed by EXM)
7	C/W Special handle sold separately (Kit)
8	C/W Mounting feet sold separately (Installed)
9	C/W Struts Welded (Included)
10	C/W Interlock Kit (Installed by EXM)

No.	Revisions	Date	By/Par

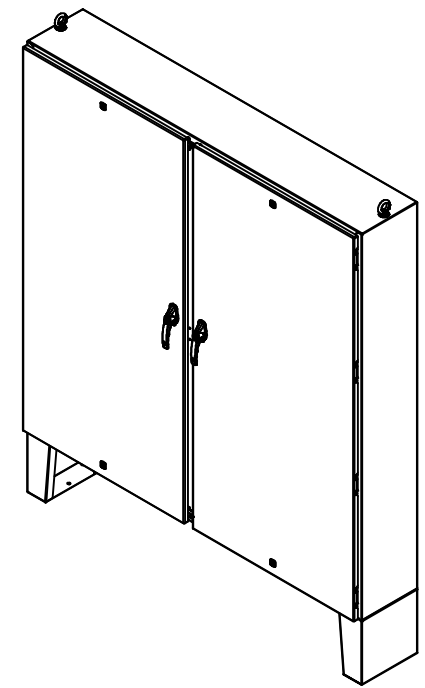

Isometric View



Tél: (450) 979-4373
 Fax: (450) 979-4626
www.exmweb.com

Flatness
Aplatissement
Max 3.0mm
Projection

Customer Client
 Drawn By Dessiné Par BoxCad: BoxCad
 Date 21-Jan-26

Material Matière 12 Ga Cold Rolled A1008 CS Type B (2.5mm)

Color Couleur Asa-61 Grey
 Finish Fini Smooth

Description 5412DDS 72" x 72" x 12" Assembly
 Detail Rev.

Part Number Numéro Pièce **5412DDH727212**
 Rev. 0

Qty	Part Number	Rev	Description
1	885MFHD1212	0	885 MFHD 12" x 12" Mounting Feet
8	STK-Q-07320	0	Flange Lock Nut M10
1	885SP7272	0	885 SP7272 Inner Panel
1	880INTI	4	880 INTI - Interlock Post Kit
1	880EB14	2	Eye Bolt M14 (Pack of 2)
8	STK-Q-07620	0	M10 Plastic Spacer 0.875"
1	5412DDH727212FD	0	5412DDS 72" x 72" Master Door
1	5412DDH727212LD	0	5412DDS 72" x 72" Slave Door
1	5412DDH727212B	0	5412DDS 72" x 72" x 12" Body
2	5412DDH727212GP	0	5412DDS Gland Plate
8	STK-Q-04050-10	8	M6 x 10mm Hexagon Socket Head Machine Screw with Nyseal
Parts List			

PACKING		
ITEM	QTY	DESCRIPTION
Cardboard sleeve	2	Top and Bottom
Cardboard strip	2	Between back of enclosure and inner panel
Plastic bag	1	To protect cover surface and inside gasket
Cardboard corner	4	To reinforced for the plastic strap tightening
Plastic strap - Black	2	To Squeeze 2 cardboard sleeve together
Packaging label	3	White label with PN
Plastic strap- Green	2	To secure the enclosure to the wood pallet
Wood Pallet	1	2" deeper and 3" larger than enclosure size

This drawing is confidential and must not be reproduced or used without the consent of EXM

Ce dessin est confidentiel et ne doit pas être reproduit ou utilisé sans le consentement de EXM

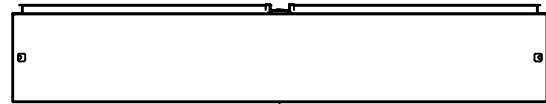

TOP

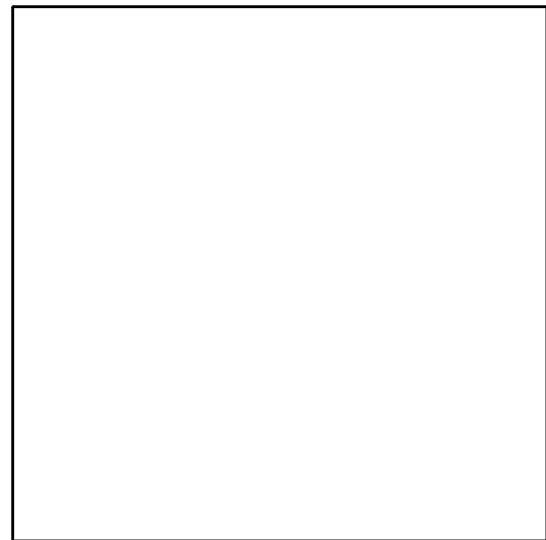

BACK



LEFT

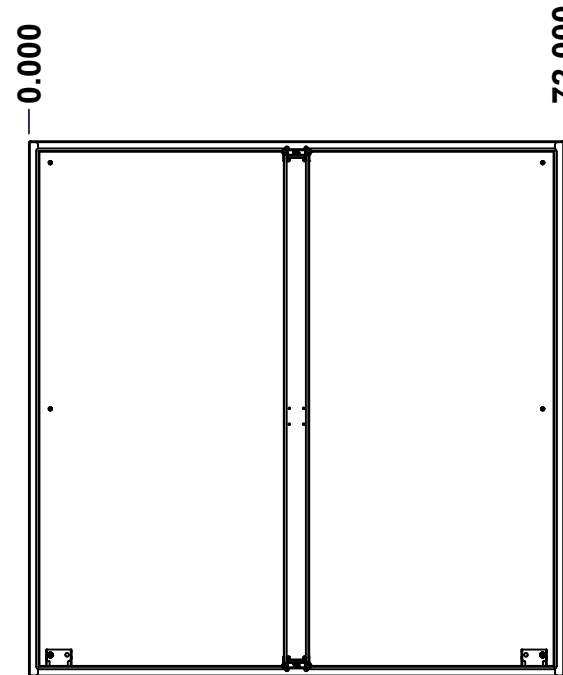

FRONT

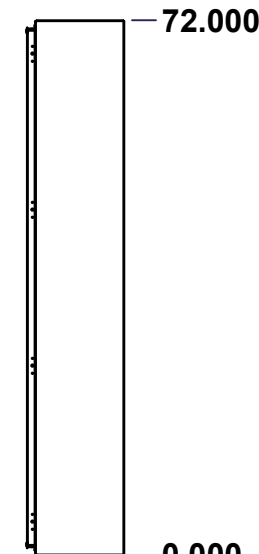

RIGHT

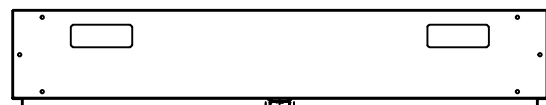

BOTTOM

No.	Revisions	Date	By/Par

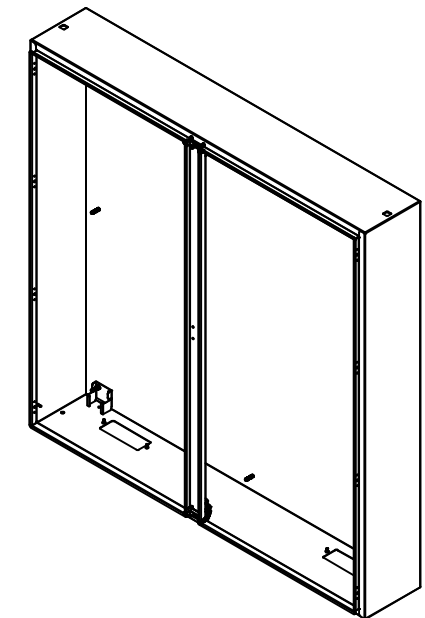

Isometric View



Tél: (450) 979-4373
 Fax: (450) 979-4626
www.exmweb.com

Flatness
Aplatissement

Max 3.0mm

Projection

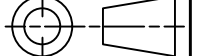

Customer Client _____ Date _____

Drawn By Dessiné Par BoxCad: BoxCad Date 21-Jan-26

Material Matière 12 Ga Cold Rolled A1008 CS Type B (2.5mm)

Color Couleur Asa-61 Grey Finish Fini Smooth

Description 5412DDS 72" x 72" x 12" Body Detail Rev. _____

Part Number Numéro Pièce **5412DDH727212B** Rev. **0** 3/18

SEE BILL OF MATERIAL ON LAST PAGE

This drawing is confidential and must not be reproduced or used without the consent of EXM

Ce dessin est confidentiel et ne doit pas être reproduit ou utilisé sans le consentement de EXM

STANDARD FEATURES ARE NOT LISTED IN THIS HOLE TABLE

HOLE TABLE - TOP VIEW (CUSTOM FEATURE ONLY)

CUT-OUT	XDIM	YDIM	DESCRIPTION
1	54.000	8.000	Struts CR400 27.500" (Inside)
2	18.000	8.000	Struts CR400 27.500" (Inside)
3	54.000	8.929	STUDS M6 x 10mm (Inside)
4	67.866	8.000	STUDS M6 x 10mm (Inside)
5	18.000	8.929	STUDS M6 x 10mm (Inside)
6	31.866	8.000	STUDS M6 x 10mm (Inside)

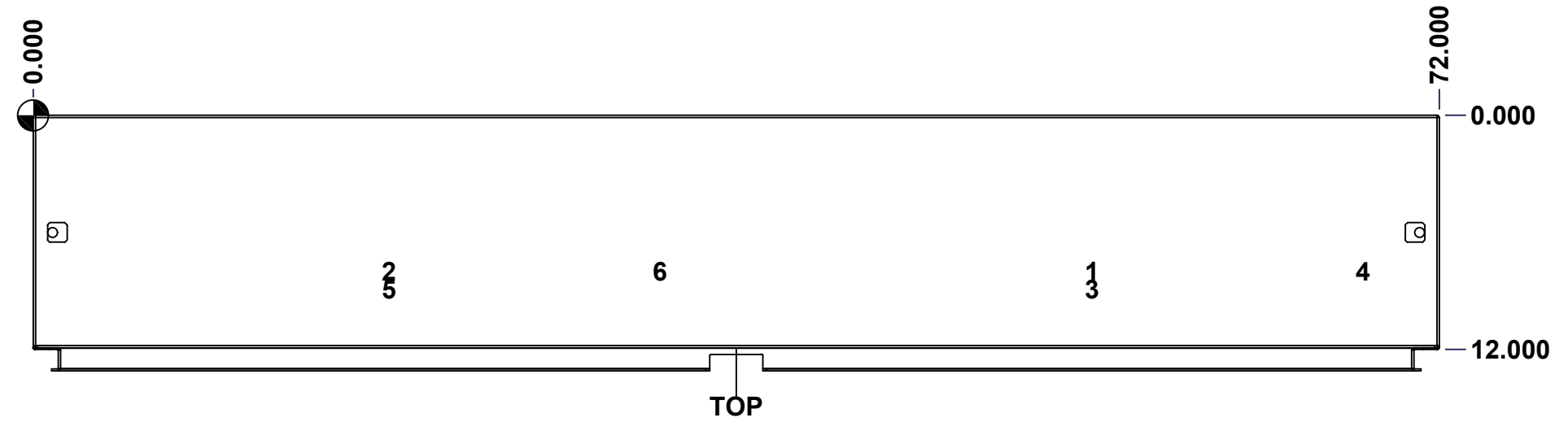

	Description	Status	
	5412DDS 72" x 72" x 12" Body	(NULL)	
	Part Number Numéro Pièce	Rev.	
	5412DDH727212B	0	4
			18

This drawing is confidential and must not be reproduced or used without the consent of EXM

Ce dessin est confidentiel et ne doit pas être reproduit ou utilisé sans le consentement de EXM

STANDARD FEATURES ARE NOT LISTED IN THIS HOLE TABLE			
HOLE TABLE - RIGHT VIEW (CUSTOM FEATURE ONLY)			
CUT-OUT	XDIM	YDIM	DESCRIPTION
1	10.500	3.375	GND STUD M6 x 16mm (Inside)

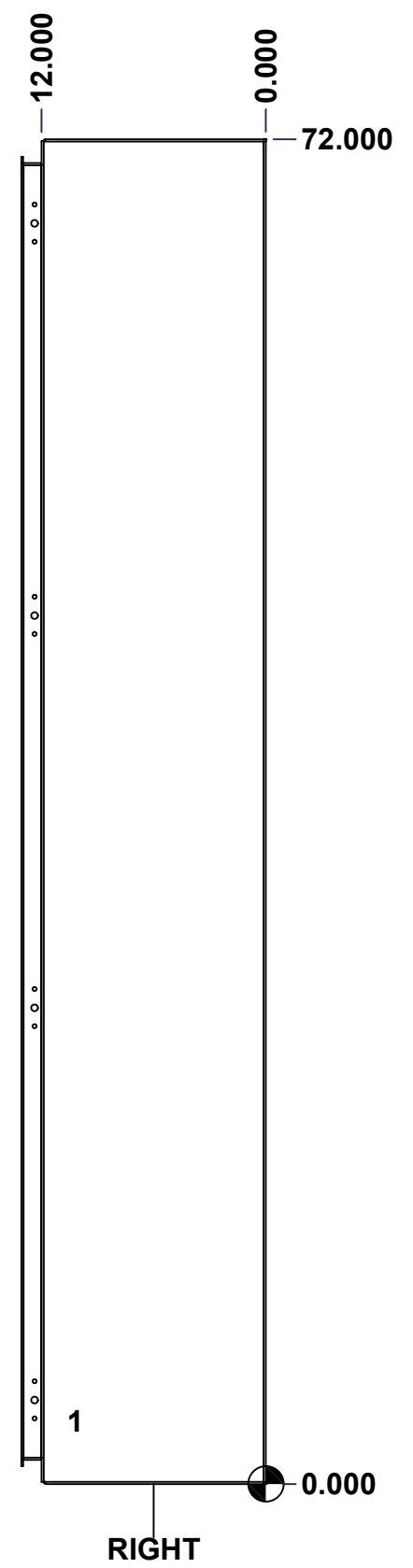

	Description	Status
	5412DDS 72" x 72" x 12" Body	(NULL)
	Part Number Numéro Pièce	Rev.
	5412DDH727212B	0
		5
		18

This drawing is confidential and must not be reproduced or used without the consent of EXM

Ce dessin est confidentiel et ne doit pas être reproduit ou utilisé sans le consentement de EXM

STANDARD FEATURES ARE NOT LISTED IN THIS HOLE TABLE

HOLE TABLE - BOTTOM VIEW (CUSTOM FEATURE ONLY)

CUT-OUT	XDIM	YDIM	DESCRIPTION
1	7.375	3.500	GP STUD M6 x 16mm (Inside)
2	16.625	3.500	GP STUD M6 x 16mm (Inside)
3	55.375	3.500	GP STUD M6 x 16mm (Inside)
4	64.625	3.500	GP STUD M6 x 16mm (Inside)

5	4.000	1.000	RND Ø0.500
6	1.000	6.000	RND Ø0.500
7	4.000	11.000	RND Ø0.500
8	68.000	1.000	RND Ø0.500
9	71.000	6.000	RND Ø0.500
10	68.000	11.000	RND Ø0.500

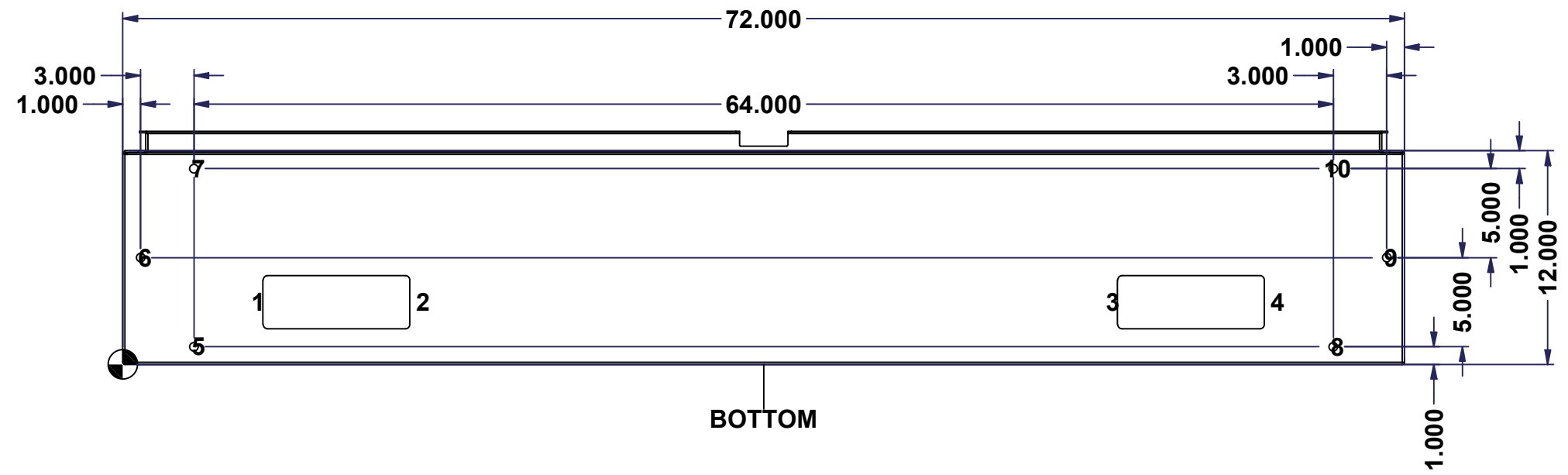

	Description	Status
	5412DDS 72" x 72" x 12" Body	(NULL)
	Part Number	Rev.
	Numéro Pièce	6
	5412DDH727212B	0
		18

This drawing is confidential and must not be reproduced or used without the consent of EXM

Ce dessin est confidentiel et ne doit pas être reproduit ou utilisé sans le consentement de EXM

STANDARD FEATURES ARE NOT LISTED IN THIS HOLE TABLE			
HOLE TABLE - LEFT VIEW (CUSTOM FEATURE ONLY)			
CUT-OUT	XDIM	YDIM	DESCRIPTION
1	10.500	3.375	GND STUD M6 x 16mm (Inside)

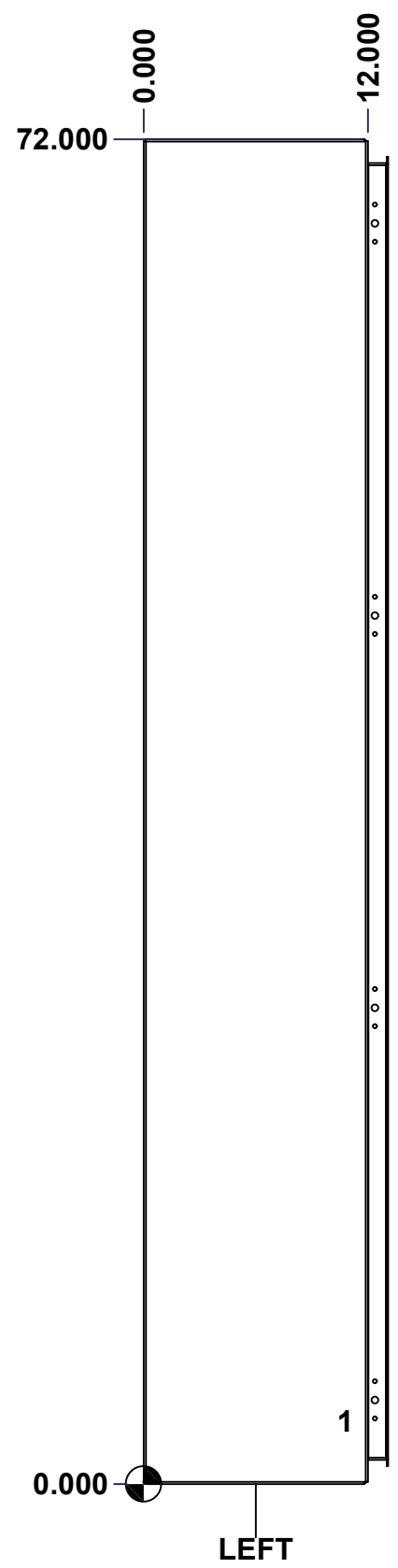

	Description	Status	
	5412DDS 72" x 72" x 12" Body	(NULL)	
	Part Number Numéro Pièce	Rev.	7
	5412DDH727212B	0	18

This drawing is confidential and must not be reproduced or used without the consent of EXM

Ce dessin est confidentiel et ne doit pas être reproduit ou utilisé sans le consentement de EXM

STANDARD FEATURES ARE NOT LISTED IN THIS HOLE TABLE			
HOLE TABLE - BACK VIEW (CUSTOM FEATURE ONLY)			
CUT-OUT	XDIM	YDIM	DESCRIPTION
1	2.875	2.875	IP STUD M10 x 40mm (Inside)
2	69.125	2.875	IP STUD M10 x 40mm (Inside)
3	2.875	36.000	IP STUD M10 x 40mm (Inside)
4	69.125	36.000	IP STUD M10 x 40mm (Inside)
5	2.875	69.125	IP STUD M10 x 40mm (Inside)
6	69.125	69.125	IP STUD M10 x 40mm (Inside)
7	36.000	2.875	IP STUD M10 x 40mm (Inside)
8	36.000	69.125	IP STUD M10 x 40mm (Inside)

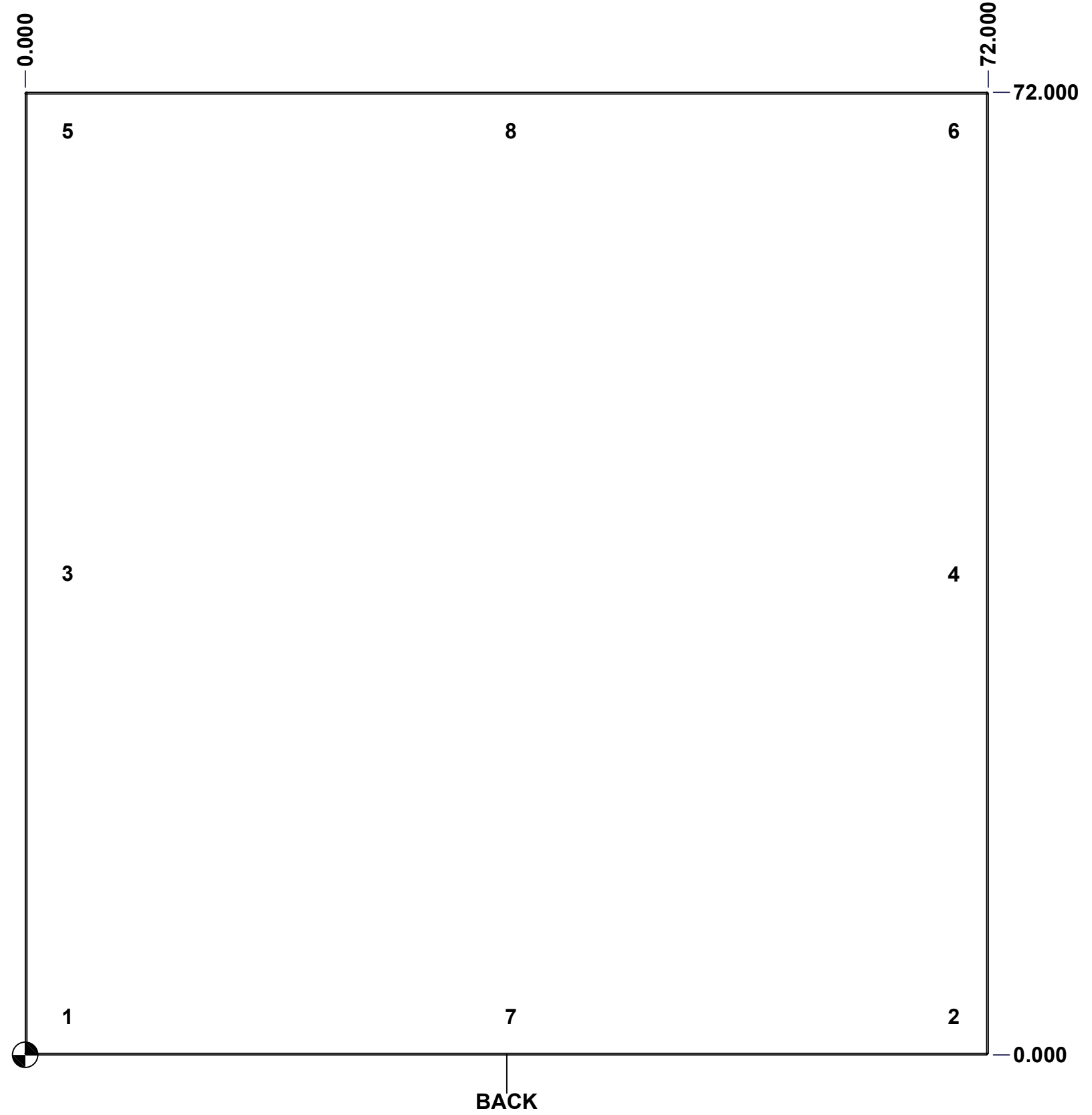

	Description	Status
	5412DDS 72" x 72" x 12" Body	(NULL)
	Part Number Numéro Pièce	Rev.
	5412DDH727212B	0 / 8
		18

This drawing is confidential and must not be reproduced or used without the consent of EXM

Ce dessin est confidentiel et ne doit pas être reproduit ou utilisé sans le consentement de EXM

STANDARD FEATURES ARE NOT LISTED IN THIS HOLE TABLE

HOLE TABLE - CENTER VIEW (CUSTOM FEATURE ONLY)

CUT-OUT	XDIM	YDIM	DESCRIPTION
1	0.748	32.179	PEM FH-M6-15ZI (Inside)
2	0.748	34.305	PEM FH-M6-15ZI (Inside)
3	2.717	32.179	PEM FH-M6-15ZI (Inside)
4	2.717	34.305	PEM FH-M6-15ZI (Inside)

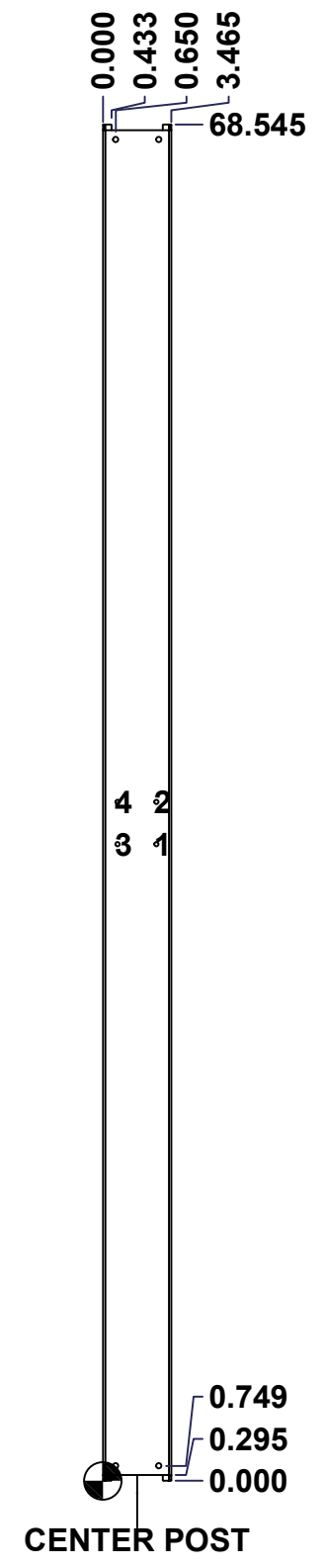

	Description	Status
	5412DDS 72" x 72" x 12" Body	(NULL)
	Part Number Numéro Pièce	Rev.
	5412DDH727212B	0 / 9
		18

This drawing is confidential and must not be reproduced or used without the consent of EXM

Ce dessin est confidentiel et ne doit pas être reproduit ou utilisé sans le consentement de EXM

No.	Revisions	Date	By/Par

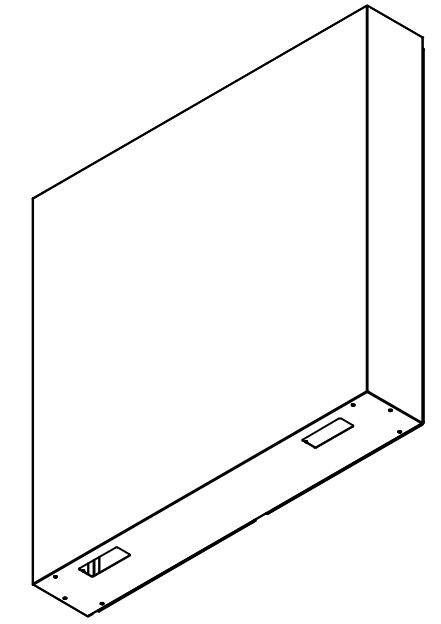

Isometric View



4	STK-Q-16030	0	Stud M6 x 10mm Steel
4	STK-PEM-FH-M6-15ZI	0	PEM Self-Clinching Stud M6 x 15.0mm
1	STK-P-02400S	0	Powder Paint (Asa-61 Grey / Smooth)
2	STK-Q-74900	0	Eyebolt Lifting Angle (8.750")
8	STK-Q-04056-12	0	M6 x 8mm Hexagon Socket Head Machine Screw with Nyseal
1	STK-K-75454	14	Center Post Freestanding Sealing Block with Latch Kit
1	5412DDH727212CP-P	0	5412DDS 72" Center Post Part
2	STK-Q-07320	0	Flange Lock Nut M10
2	STK-Q-07618	1	5500 Series Inner Panel Support Bracket
8	STK-Q-16100	0	Stud M10 x 40mm Steel
1	5412DDH727212B-P	0	5412DDS 72" x 72" Body Part
2	5412DDH727212_CR400 MS_27.5	0	Commercial Roll Mild Steel (27.5in long)
6	STK-Q-16080	0	Ground Stud M6 x 16mm Steel

Qty	Part Number	Rev	Description
Parts List			

Tél: (450) 979-4373 Fax: (450) 979-4626 www.exmweb.com	Flatness Aplatissement	Max 3.0mm
	Projection	
Customer Client	Date	
Drawn By Dessiné Par	BoxCad: BoxCad	Date 21-Jan-26
Material Matière	12 Ga Cold Rolled A1008 CS Type B (2.5mm)	
Color Couleur	Asa-61 Grey	Finish Fini Smooth
Description	Detail Rev.	
5412DDS 72" x 72" x 12" Body		
Part Number Numéro Pièce	Rev.	10
5412DDH727212B	0	18

This drawing is confidential and must not be reproduced or used without the consent of EXM

Ce dessin est confidentiel et ne doit pas être reproduit ou utilisé sans le consentement de EXM

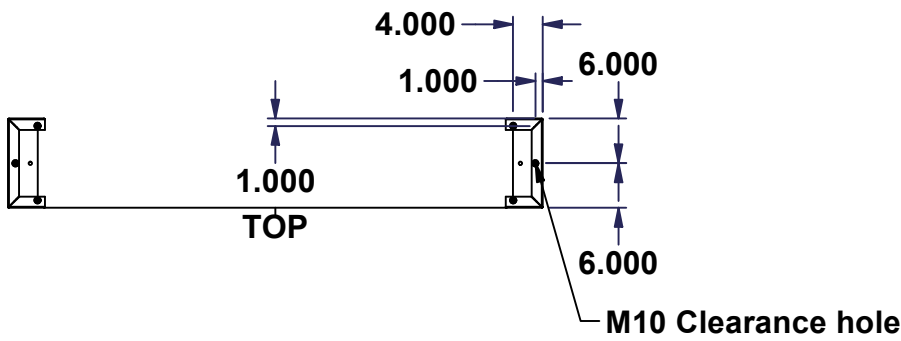

ENCLOSURE CUTOUT LAYOUT

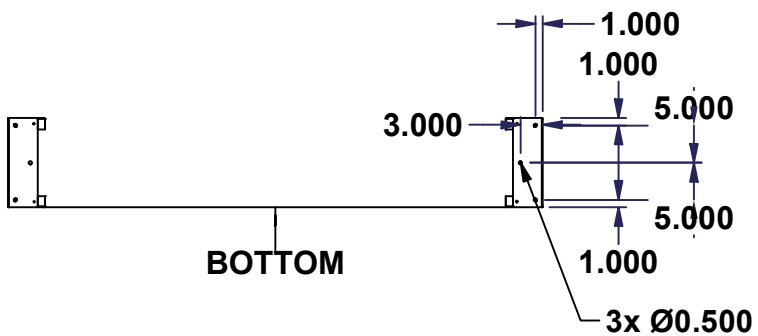
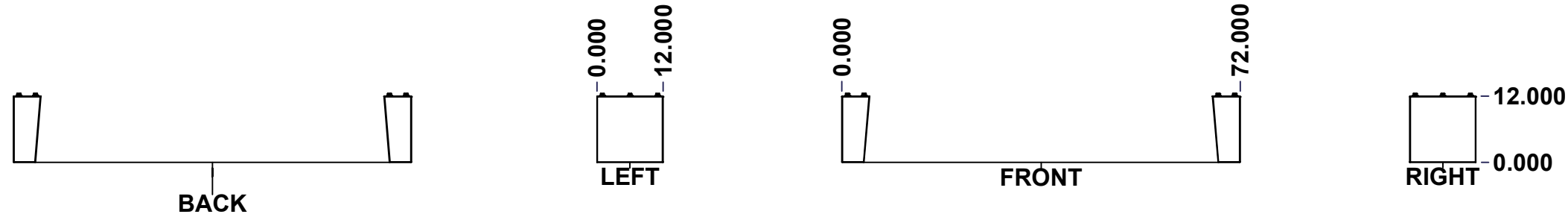

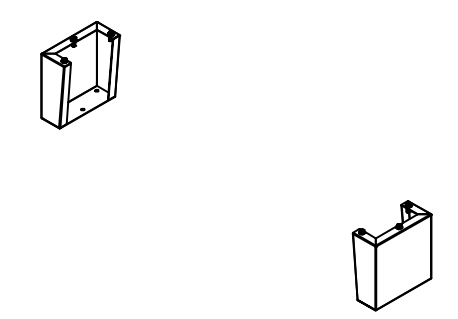

FLOOR ANCHORAGE LAYOUT

No.	Revisions	Date	By/Par

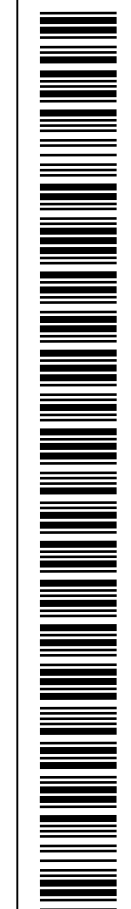

Isometric View

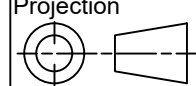

 Tél: (450) 979-4373 Fax: (450) 979-4626 www.exmweb.com		Flatness Aplatissement
		Max 3.0mm
Projection		
Customer Client	Date	
Drawn By Dessiné Par	BoxCad: BoxCad	Date 21-Jan-26
Material Matière	12 Ga Cold Rolled A1008 CS Type B (2.5mm)	
Color Couleur	Asa-61 Grey	Finish Fini Smooth
Description		Detail Rev.
885 MFHD 12" x 12" Mounting Feet		
Part Number Numéro Pièce	Rev.	11
SEE BILL OF MATERIAL ON LAST PAGE	885MFHD1212	0

This drawing is confidential and must not be reproduced or used without the consent of EXM

Ce dessin est confidentiel et ne doit pas être reproduit ou utilisé sans le consentement de EXM

No.	Revisions	Date	By/Par

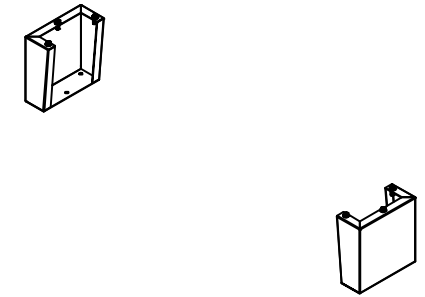

Isometric View

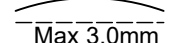
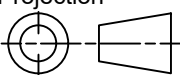

 Tél: (450) 979-4373 Fax: (450) 979-4626 www.exmweb.com		Flatness Aplatissement  Max 3.0mm Projection 
Customer Client	Date	
Drawn By Dessiné Par	BoxCad: BoxCad	Date 21-Jan-26
Material Matière	12 Ga Cold Rolled A1008 CS Type B (2.5mm)	
Color Couleur	Asa-61 Grey	Finish Fini Smooth
Description		Detail Rev.
885 MFHD 12" x 12" Mounting Feet		
Part Number Numéro Pièce	Rev.	12
885MFHD1212	0	18

Qty	Part Name	Rev	Description
1	STK-P-02400S	0	Powder Paint (Asa-61 Grey / Smooth)
6	RIVET_NUT_M10_FH_CE	0	Rivet Nut M10 (Low Profile Close End)
1	5412DDH727212MFR-P	0	885 MFHD 12" x 12" Right Mounting Feet Part
1	5412DDH727212MFL-P	0	885 MFHD 12" x 12" Left Mounting Feet Part
3	STK-K-11600	2	885 MF Accessory Kit
Parts List			

This drawing is confidential and must not be reproduced or used without the consent of EXM

Ce dessin est confidentiel et ne doit pas être reproduit ou utilisé sans le consentement de EXM

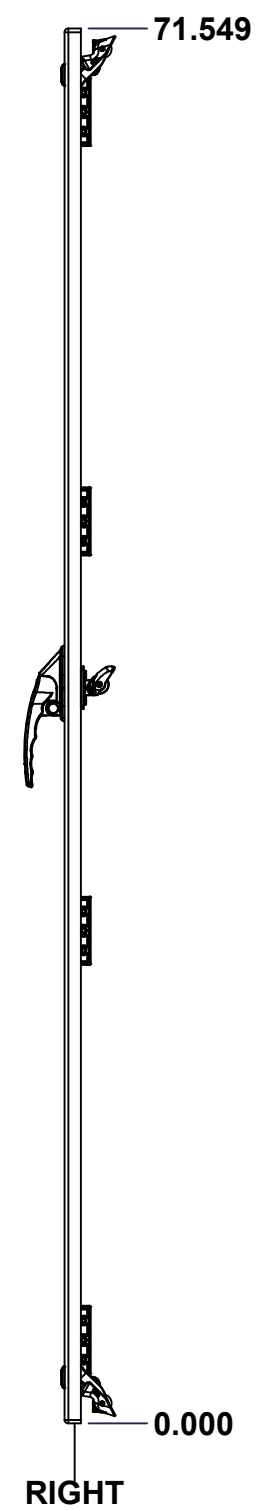
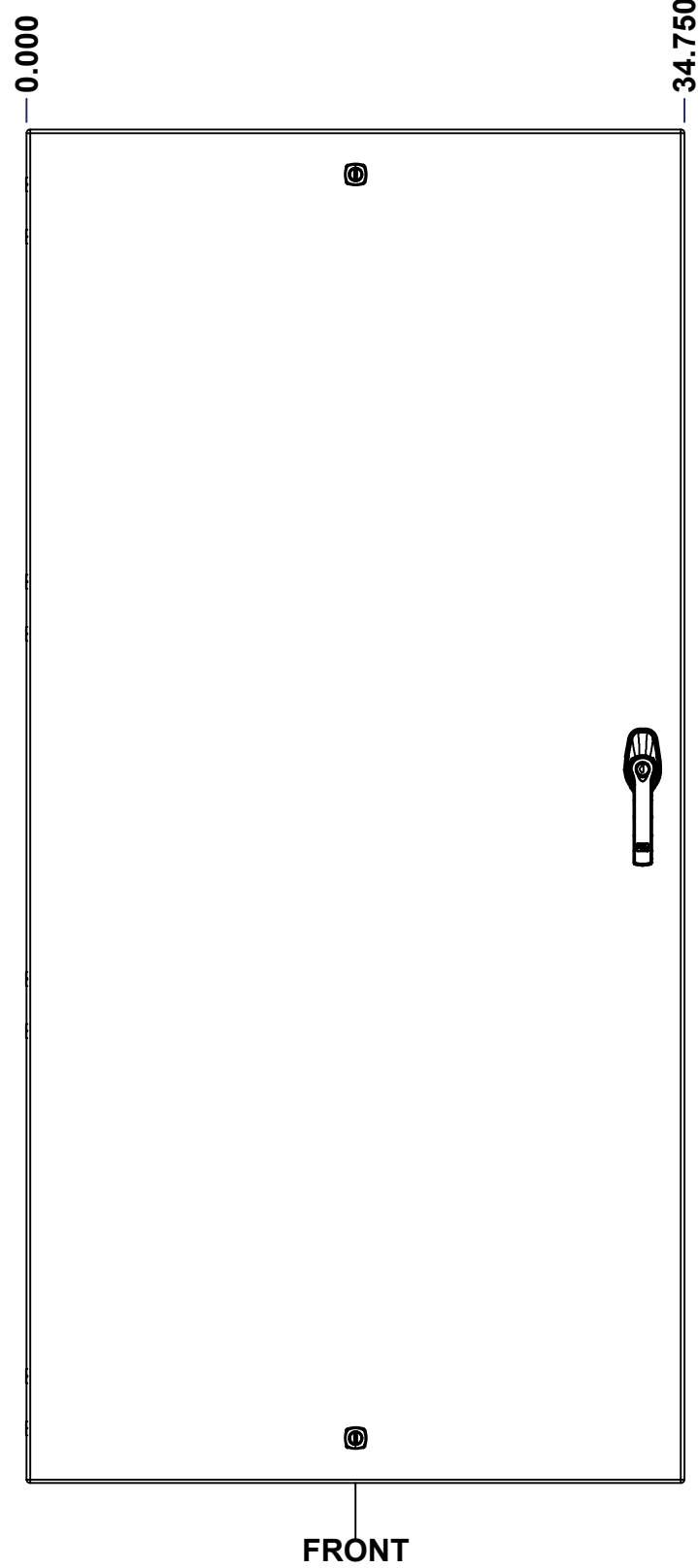
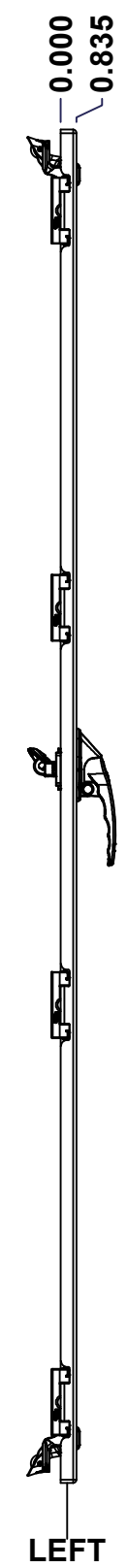
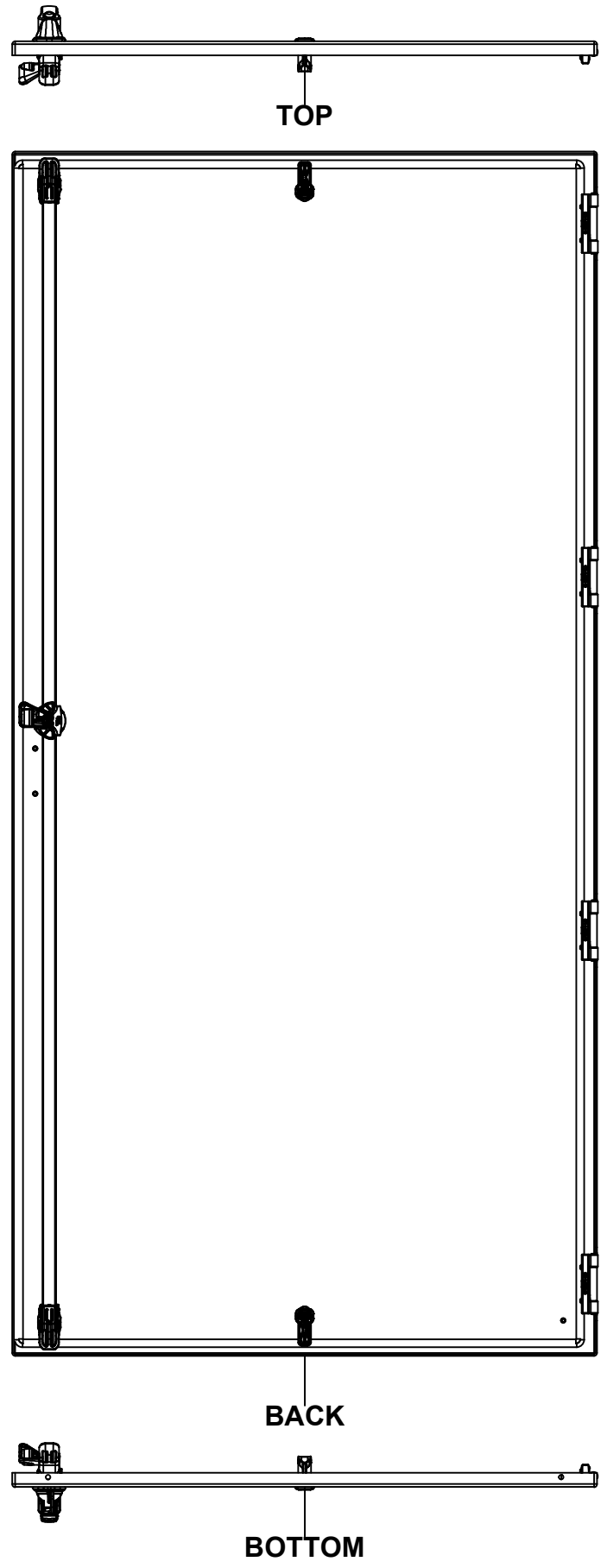

No.	Revisions	Date	By/Par

Isometric View

<p>Tél: (450) 979-4373 Fax: (450) 979-4626 www.exmweb.com</p>		Flatness Aplatissement
		Max 3.0mm
		Projection
Customer Client		Date
Drawn By Dessiné Par	BoxCad: BoxCad	Date 21-Jan-26
Material Matière	12 Ga Cold Rolled A1008 CS Type B (2.5mm)	
Color Couleur	Asa-61 Grey	Finish Fini Smooth
Description		Detail Rev.
5412DDS 72" x 72" Slave Door		
Part Number Numéro Pièce	Rev. 13	18
SEE BILL OF MATERIAL ON LAST PAGE		0
5412DDH727212LD		

This drawing is confidential and must not be reproduced or used without the consent of EXM

Ce dessin est confidentiel et ne doit pas être reproduit ou utilisé sans le consentement de EXM

STANDARD FEATURES ARE NOT LISTED IN THIS HOLE TABLE

HOLE TABLE - FRONT VIEW (CUSTOM FEATURE ONLY)

CUT-OUT	XDIM	YDIM	DESCRIPTION
1	32.546	6.118	LARGE CBAR GUIDE (Inside)
2	32.546	65.430	LARGE CBAR GUIDE (Inside)
-----	-----	-----	-----
3	32.546	37.743	HANDLE 885 ESL2A-APHK @ 0.0°
4	17.375	69.180	LOCK 889 SCQ4-SL @ 90.0°
5	17.375	2.368	LOCK 889 SCQ4-SL @ 270.0°
6	2.000	2.118	GND STUD M6 x 16mm (Inside)
7	33.372	33.404	STUDS M6 x 18mm (Inside)
8	33.372	36.082	STUDS M6 x 18mm (Inside)

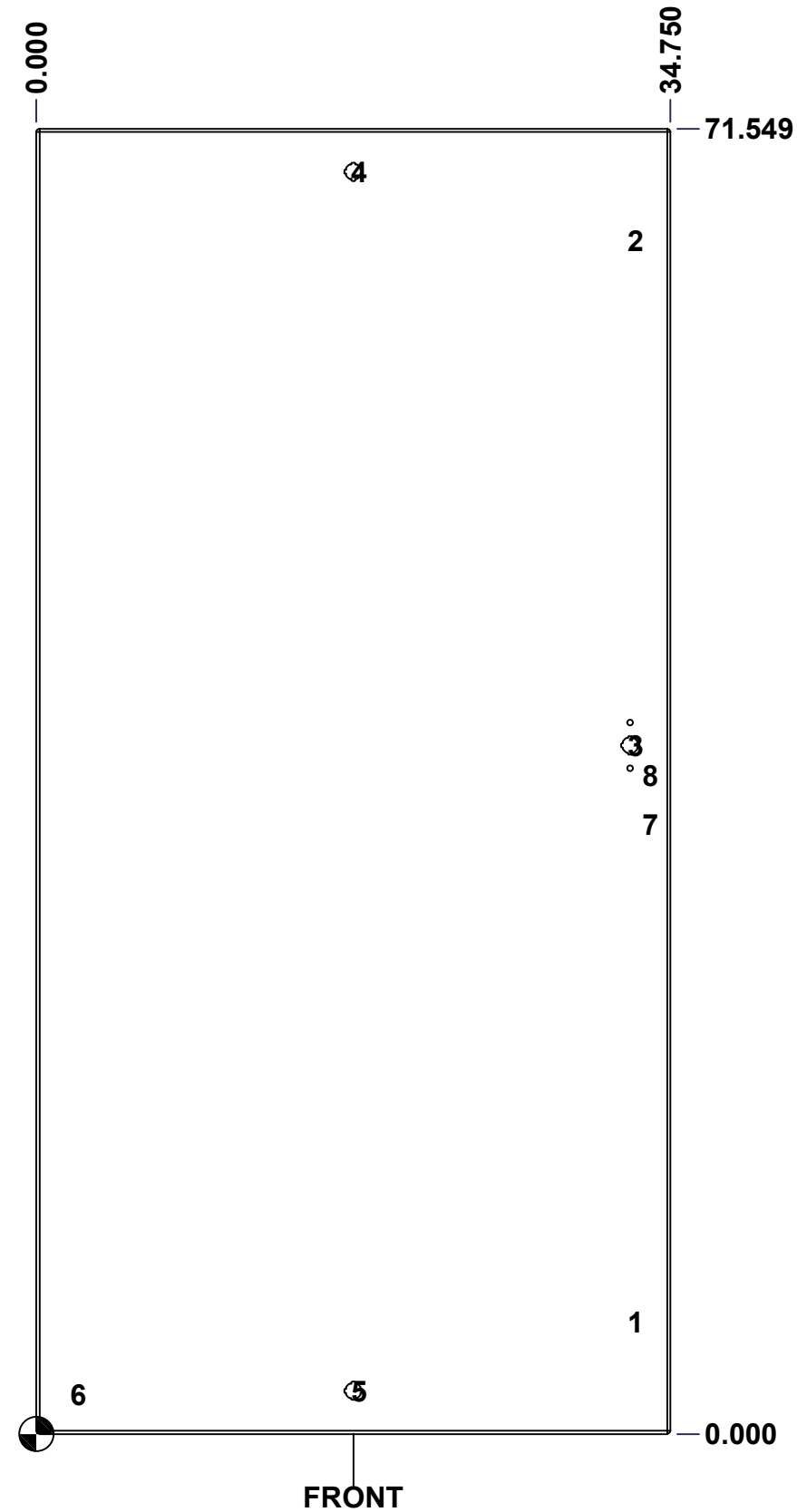

FRONT

	Description	Status
	5412DDS 72" x 72" Slave Door	(NULL)
	Part Number Numéro Pièce	Rev.
	5412DDH727212LD	0
		14
		18

This drawing is confidential and must not be reproduced or used without the consent of EXM

Ce dessin est confidentiel et ne doit pas être reproduit ou utilisé sans le consentement de EXM

No.	Revisions	Date	By/Par

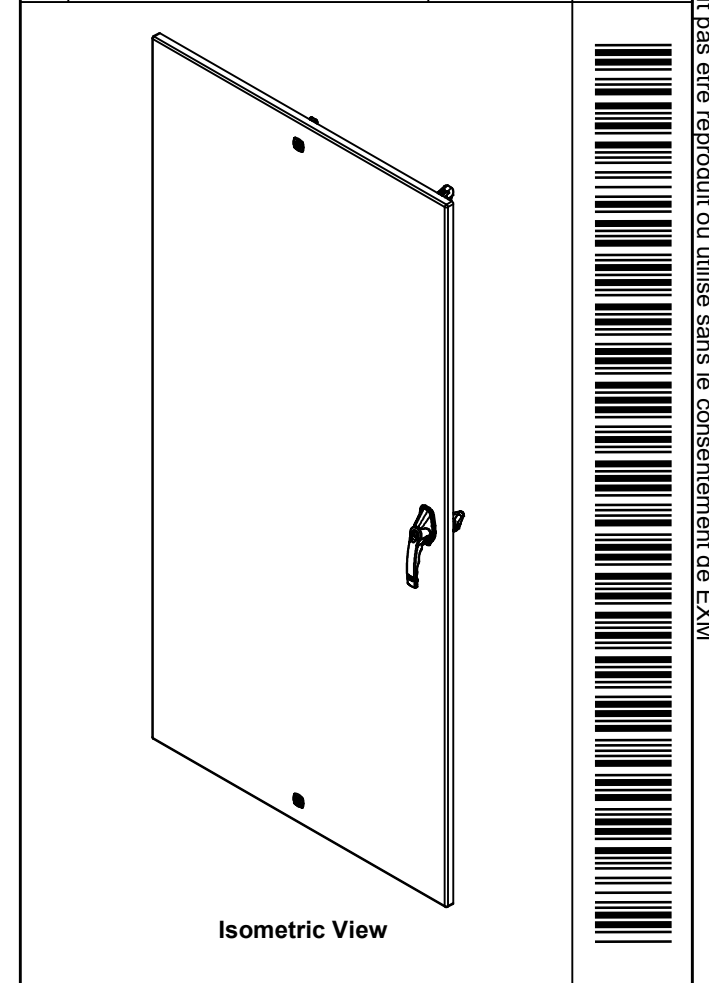

2	STK-Q-16050	1	Stud M6 x 18mm Steel
1	STK-Q-16080	0	Ground Stud M6 x 16mm Steel
2	STK-Q-07220	1	M6 Nylon Insert Lock Nut
1	STK-Q-47542	1	5500 DDS Lower Closing Bar 72"
1	STK-Q-47532	0	5500 DDS Upper Closing Bar 72"
1	STK-A-50538	3	9500 Handle Cam Assembly (Right Side, Grip 36mm)
1	STK-Q-90051	3	5412 ES - Handle Cam Spacer
1	885ESL2A-APHK	7	885 ESL2A-APHK - Zinc Die Cast L-Handle Padlockable Assy
1	STK-P-02400S	0	Powder Paint (Asa-61 Grey / Smooth)
2	STK-Q-16410	0	Guide Stud - Largel (No Paint Cap Required)
1	5412DDH727212DG	0	5412DDS 72" x 72" Door Gasket
1	5412DDH727212LD-P	0	5412DDS 72" x 72" Slave Door Part
2	STK-A-90025	0	9500 - Cabinet Closing Bar End (Large)
4	STK-K-09860	7	Cabinet Hinge with Captive Pins
2	STK-K-12580	0	9412 1/4 Turn Lock

QTY	Part Number	Rev	Description
Parts List			

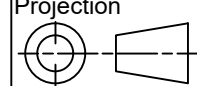
 Tél: (450) 979-4373 Fax: (450) 979-4626 www.exmweb.com	Flatness Aplatissement	Max 3.0mm
	Projection	
Customer Client	Date	
Drawn By Dessiné Par	BoxCad: BoxCad	Date 21-Jan-26
Material Matière	12 Ga Cold Rolled A1008 CS Type B (2.5mm)	
Color Couleur	Asa-61 Grey	Finish Fini Smooth
Description	Detail Rev.	
5412DDS 72" x 72" Slave Door		
Part Number Numéro Pièce	Rev. 0	15 18
5412DDH727212LD		

This drawing is confidential and must not be reproduced or used without the consent of EXM

Ce dessin est confidentiel et ne doit pas être reproduit ou utilisé sans le consentement de EXM

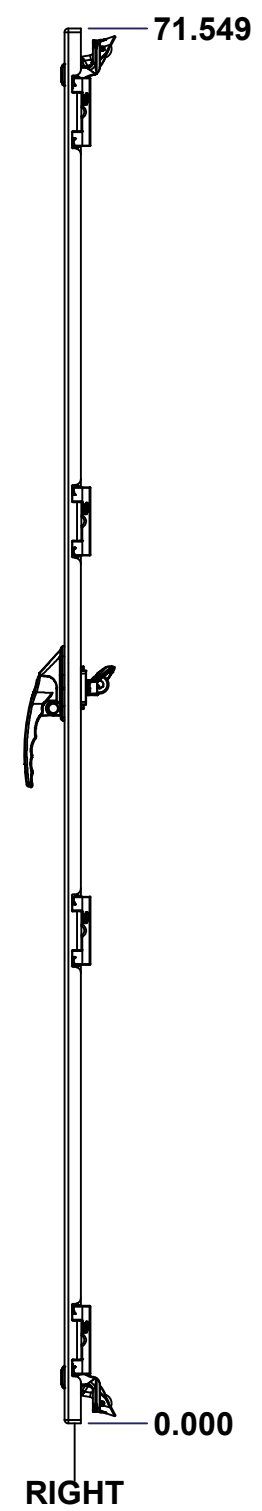
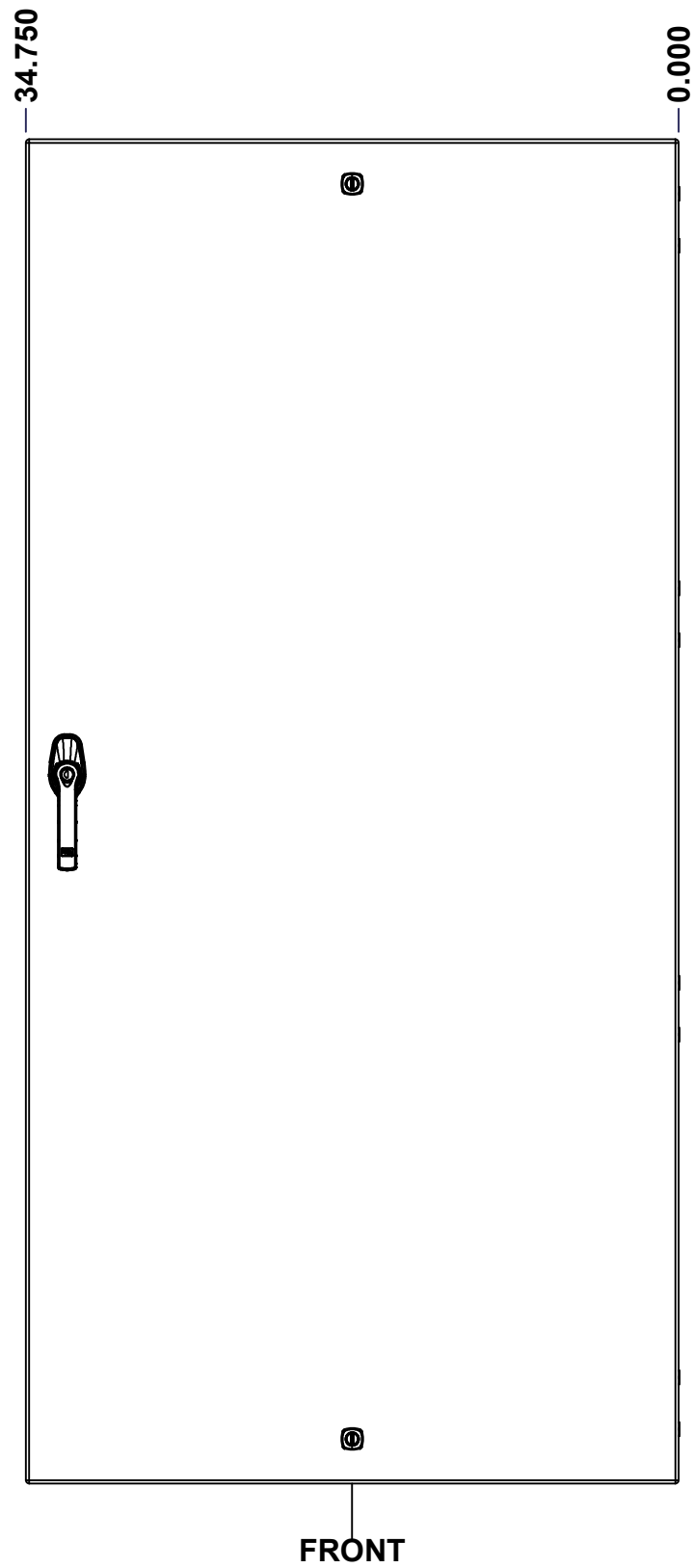
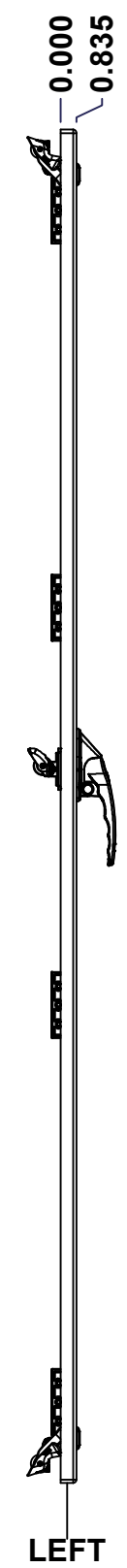
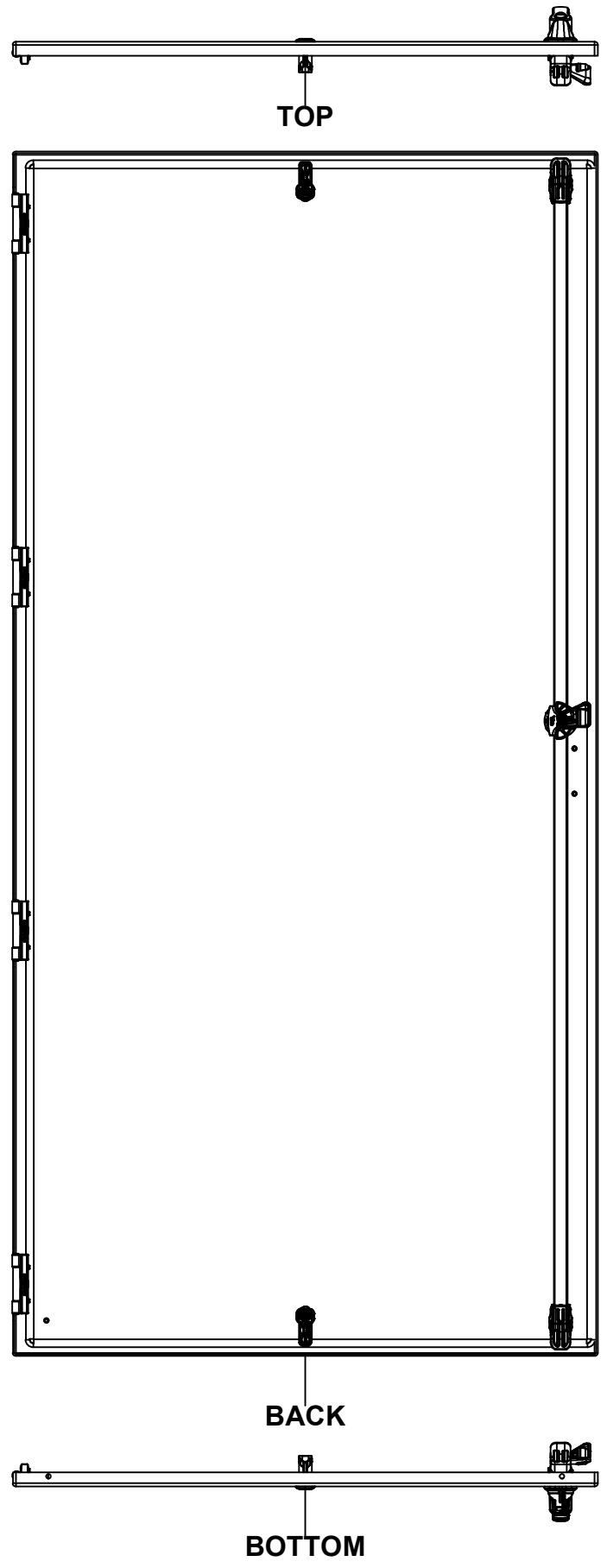

No.	Revisions	Date	By/Par

Isometric View of the door showing the handle and lock mechanism. A barcode is located to the right of the isometric view.

Tél: (450) 979-4373 Fax: (450) 979-4626 www.exmweb.com		Flatness Aplatissement Max 3.0mm Projection
Customer Client	Date	
Drawn By Dessiné Par	BoxCad: BoxCad	Date 21-Jan-26
Material Matière	12 Ga Cold Rolled A1008 CS Type B (2.5mm)	
Color Couleur	Asa-61 Grey	Finish Fini Smooth
Description 5412DDS 72" x 72" Master Door		Detail Rev.
Part Number Numéro Pièce	Rev. 0	16 18

SEE BILL OF MATERIAL ON LAST PAGE

5412DDH727212FD

This drawing is confidential and must not be reproduced or used without the consent of EXM

Ce dessin est confidentiel et ne doit pas être reproduit ou utilisé sans le consentement de EXM

STANDARD FEATURES ARE NOT LISTED IN THIS HOLE TABLE			
HOLE TABLE - FRONT VIEW (CUSTOM FEATURE ONLY)			
CUT-OUT	XDIM	YDIM	DESCRIPTION
1	32.546	6.118	LARGE CBAR GUIDE (Inside)
2	32.546	65.430	LARGE CBAR GUIDE (Inside)

3	32.546	37.743	HANDLE 885 ESL2A-APHK
4	17.375	69.180	LOCK 889 SCQ4-SL @ 90.0°
5	17.375	2.368	LOCK 889 SCQ4-SL @ 270.0°
6	2.000	2.118	GND STUD M6 x 16mm (Inside)
7	33.372	33.404	STUDS M6 x 18mm (Inside)
8	33.372	36.082	STUDS M6 x 18mm (Inside)

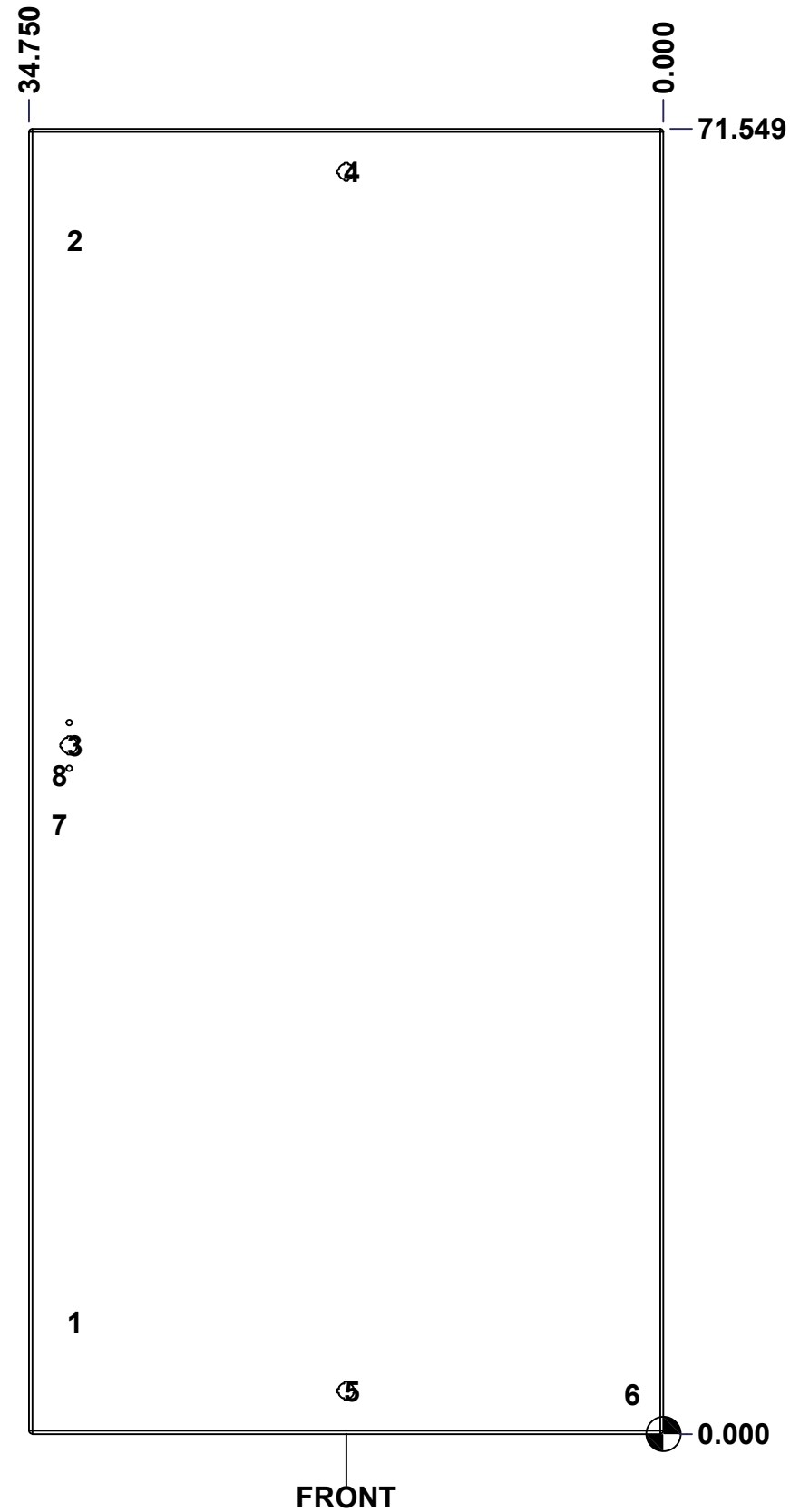

FRONT

	Description	Status
	5412DDS 72" x 72" Master Door	(NULL)
	Part Number Numéro Pièce	Rev.
	5412DDH727212FD	0
		17
		18

This drawing is confidential and must not be reproduced or used without the consent of EXM

Ce dessin est confidentiel et ne doit pas être reproduit ou utilisé sans le consentement de EXM

No.	Revisions	Date	By/Par

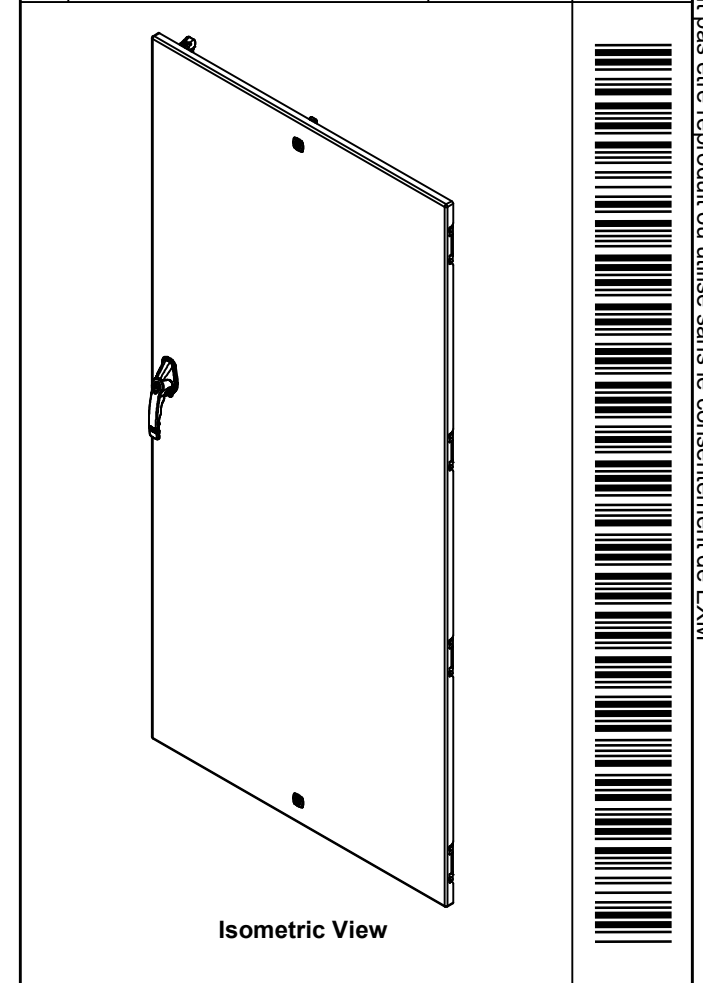

2	STK-Q-16050	1	Stud M6 x 18mm Steel
1	STK-Q-16080	0	Ground Stud M6 x 16mm Steel
2	STK-Q-07220	1	M6 Nylon Insert Lock Nut
1	STK-Q-47542	1	5500 DDS Lower Closing Bar 72"
1	STK-Q-47532	0	5500 DDS Upper Closing Bar 72"
1	STK-A-50537	3	9500 Handle Cam Assembly (Left Side, Grip 36mm)
1	STK-Q-90051	3	5412 ES - Handle Cam Spacer
1	885ESL2A-APHK	7	885 ESL2A-APHK - Zinc Die Cast L-Handle Padlockable Assy
1	STK-P-02400S	0	Powder Paint (Asa-61 Grey / Smooth)
2	STK-Q-16410	0	Guide Stud - Largel (No Paint Cap Required)
1	5412DDH727212DG	0	5412DDS 72" x 72" Door Gasket
1	5412DDH727212FD-P	0	5412DDS 72" x 72" Master Door Part
2	STK-A-90025	0	9500 - Cabinet Closing Bar End (Large)
4	STK-K-09860	7	Cabinet Hinge with Captive Pins
2	STK-K-12580	0	9412 1/4 Turn Lock

QTY	Part Number	Rev	Description
Parts List			



Tél: (450) 979-4373
Fax: (450) 979-4626
www.exmweb.com

Flatness
Aplatissement
Max 3.0mm

Projection

Customer Client

Drawn By / Dessiné Par: BoxCad: BoxCad

Material / Matière: 12 Ga Cold Rolled A1008 CS Type B (2.5mm)

Color / Couleur: Asa-61 Grey

Finish / Fini: Smooth

Description: 5412DDS 72" x 72" Master Door

Part Number / Numéro Pièce: **5412DDH727212FD**

Date

Date: 21-Jan-26

Detail Rev.

Rev. 0

18

This drawing is confidential and must not be reproduced or used without the consent of EXM

Ce dessin est confidentiel et ne doit pas être reproduit ou utilisé sans le consentement de EXM



TOP

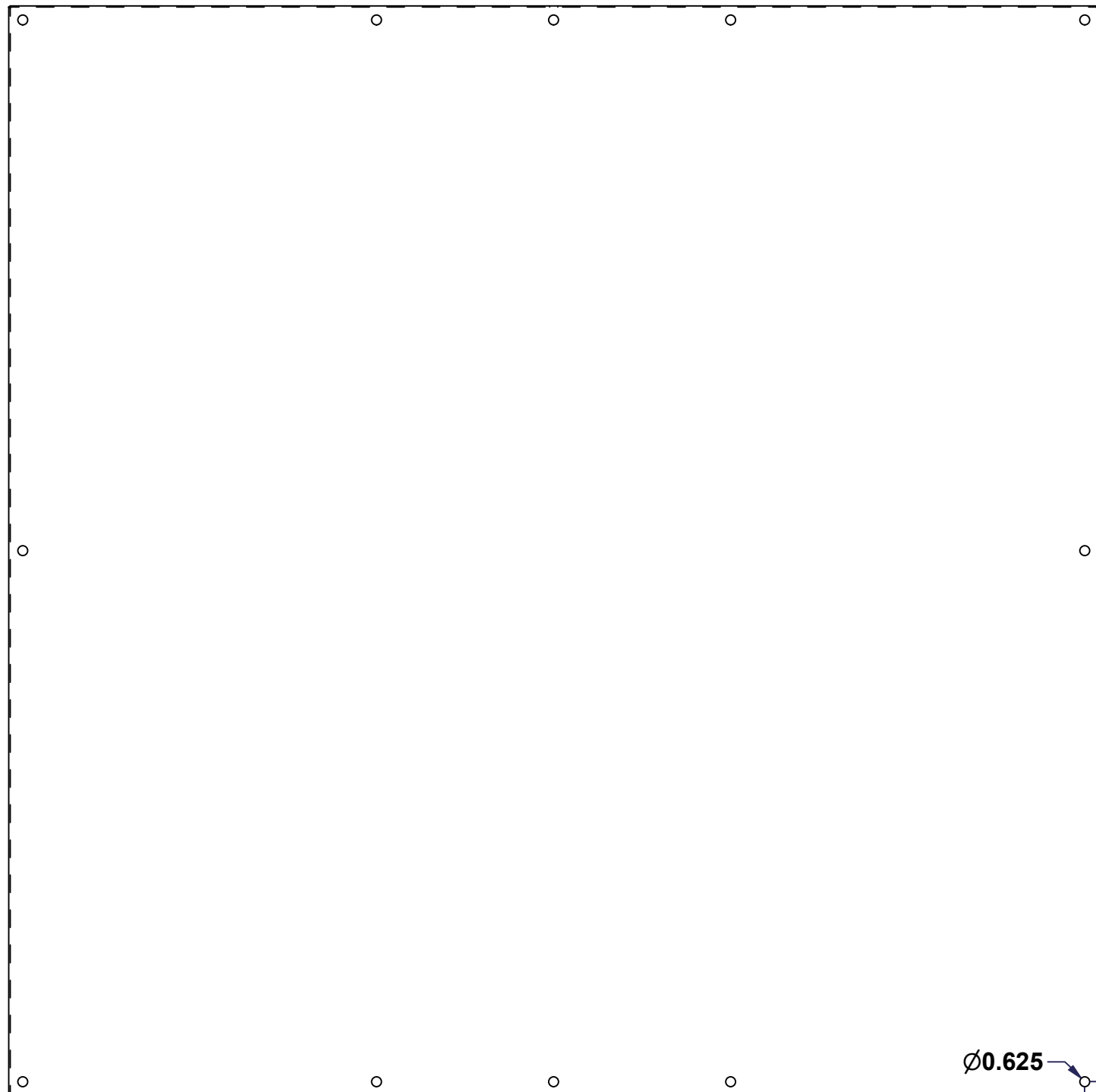

FRONT



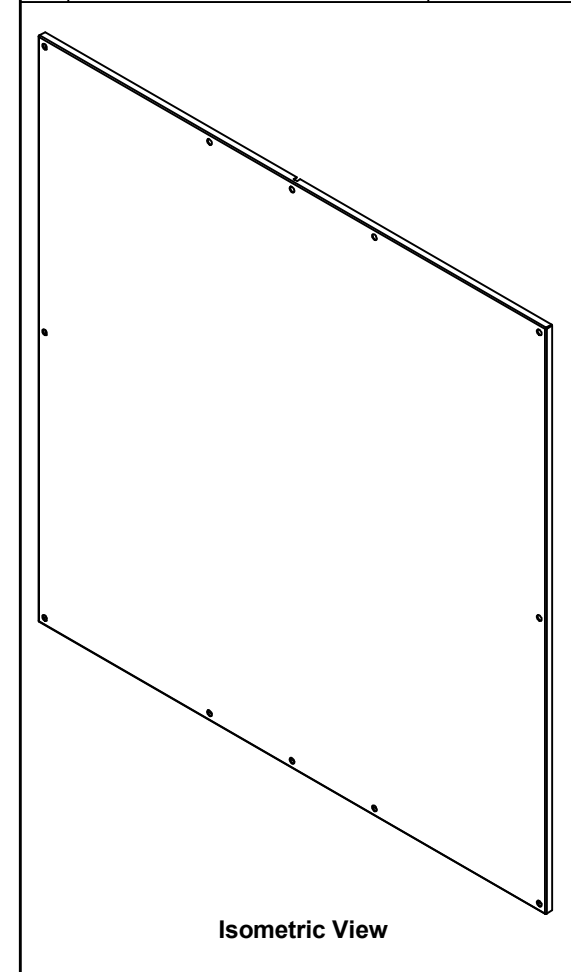

RIGHT

No.	Revisions	Date	By/Par

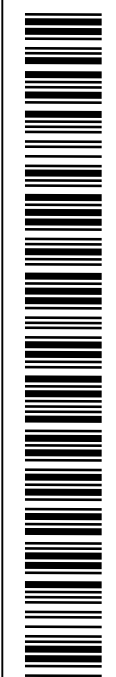

Isometric View

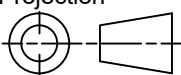

 Tél: (450) 979-4373 Fax: (450) 979-4626 www.exmweb.com	Flatness Aplatissement Max 3.0mm
	Projection 
Customer Client	Date
Drawn By Dessiné Par BoxCad	Date 04/11/2009
Material Matière 12 Ga Cold Rolled A1008 CS Type B (2.5mm)	
Color Couleur White RAL9003	Finish Fini Smooth
Description 885 SP7272 Inner Panel	
Part Number Numéro Pièce 885SP7272	Detail Rev. Rev. 1 0 2

SEE BILL OF MATERIAL ON LAST PAGE

This drawing is confidential and must not be reproduced or used without the consent of EXM

Ce dessin est confidentiel et ne doit pas être reproduit ou utilisé sans le consentement de EXM

No.	Revisions	Date	By/Par

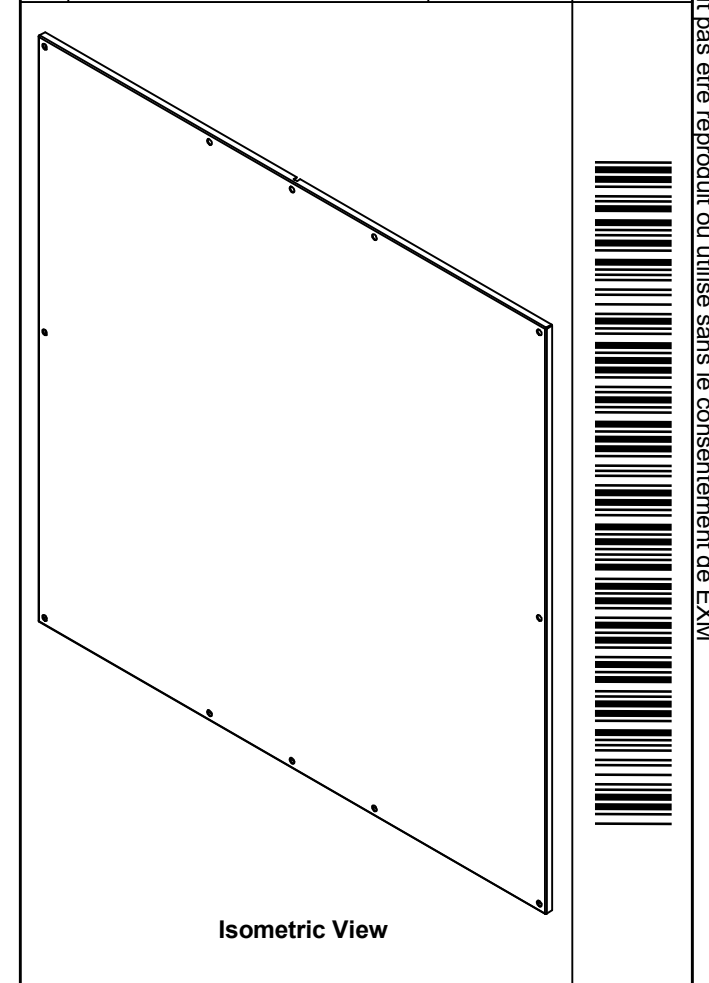

 Tél: (450) 979-4373 Fax: (450) 979-4626 www.exmweb.com		Flatness Aplatissement Max 3.0mm
Customer Client		Date
Drawn By / Dessiné Par: BoxCad		Date: 04/11/2009
Material / Matière: 12 Ga Cold Rolled A1008 CS Type B (2.5mm)		
Color / Couleur: White RAL9003	Finish / Fini: Smooth	
Description: 885 SP7272 Inner Panel		Detail Rev.
Part Number / Numéro Pièce: 885SP7272		Rev. 2 0

Qty	Part Number	Rev	Description
1	STK-P-02401S	0	Powder Paint (White / Smooth)
1	885SP7272-P	0	885 SP7272 Inner Panel Part
Parts List			