

This drawing is confidential and must not be reproduced or used without the consent of EXM

Ce dessin est confidentiel et ne doit pas être reproduit ou utilisé sans le consentement de EXM

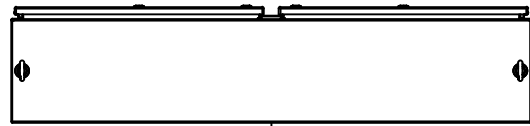

TOP

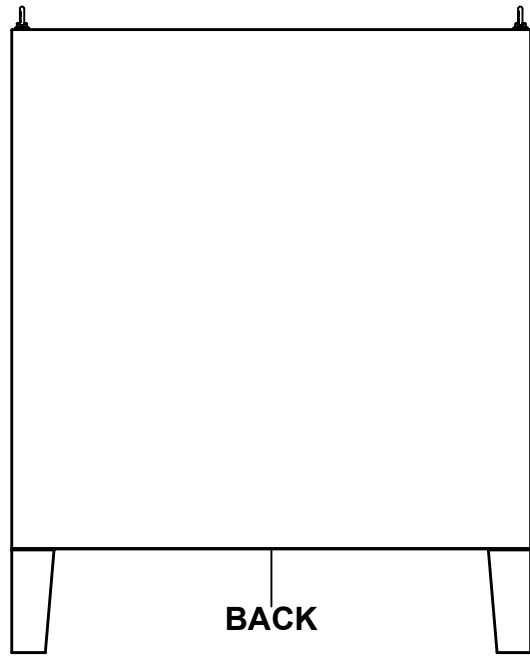

BACK

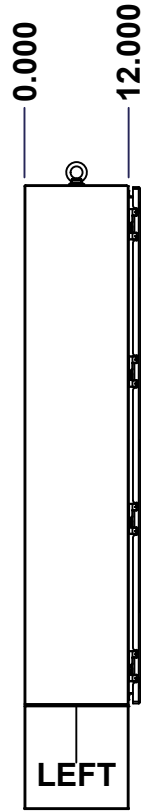

LEFT

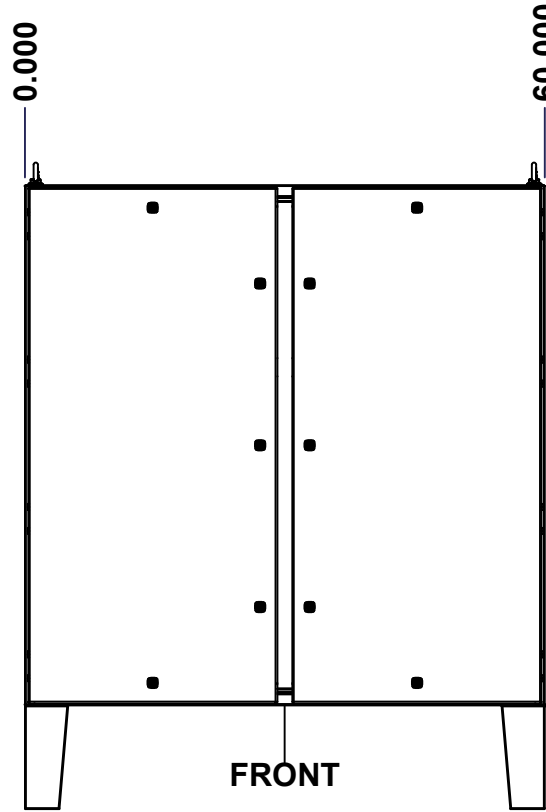

FRONT

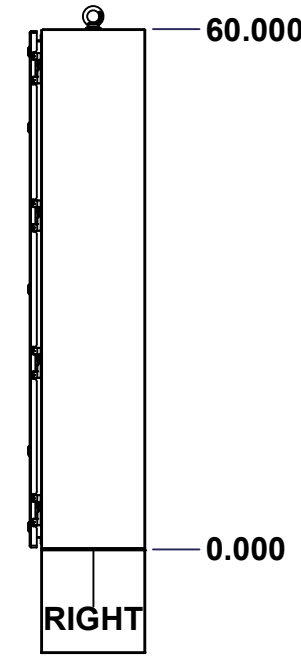

RIGHT

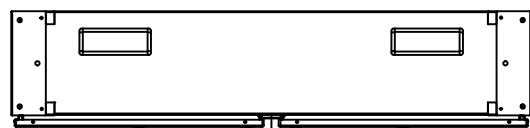

BOTTOM

No.	Revisions	Date	By/Par

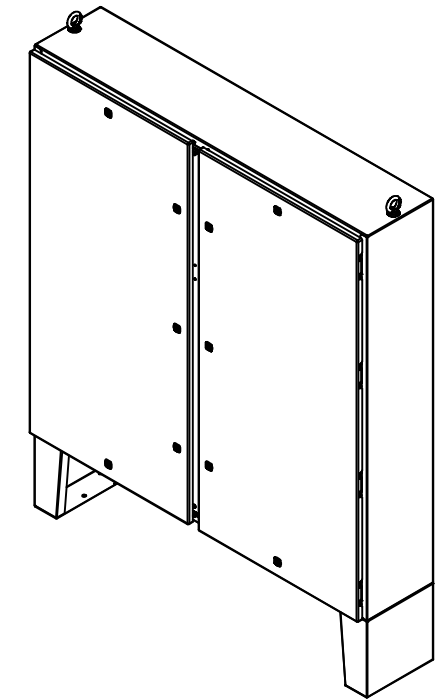

Isometric View



Tél: (450) 979-4373
 Fax: (450) 979-4626
www.exmweb.com

Flatness
Aplatissement

Max 3.0mm

Projection



Customer Client	Date
Drawn By Dessiné Par BoxCad: BoxCad	Date 18-Sep-14
Material Matière 12 Ga Cold Rolled A1008 CS Type B (2.5mm)	
Color Couleur Asa-61 Grey	Finish Fini Smooth
Description 5412DDS 60" x 60" x 12" Assembly	Detail Rev.
Part Number Numéro Pièce 5412DDS606012	Rev. 0

SEE BILL OF MATERIAL ON LAST PAGE

This drawing is confidential and must not be reproduced or used without the consent of EXM

Ce dessin est confidentiel et ne doit pas être reproduit ou utilisé sans le consentement de EXM

NOTE	
ITEM	DESCRIPTION
1	NEMA 4, 12 Enclosure (IP66)
2	C/W Standard ground studs on box and cover
3	C/W Standard door stiffener
4	C/W Standard inner panel (Included)
5	C/W Standard inner panel mounting studs
6	C/W Eyebolts sold separately (Installed by EXM)
7	C/W 880 PPL sold separately (Not installed)
8	C/W Mounting feet sold separately (Installed)
9	C/W Struts installed (Included)
10	C/W Interlock Kit (Installed by EXM)

No.	Revisions	Date	By/Par

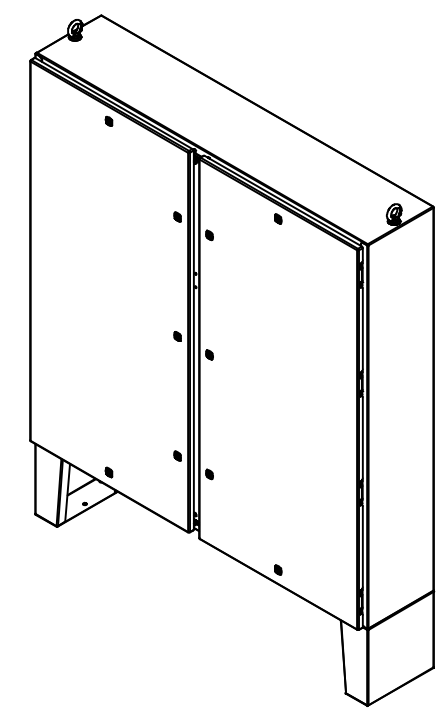

Isometric View

PACKING		
ITEM	QTY	DESCRIPTION
Cardboard sleeve	2	Top and Bottom
Cardboard strip	2	Between back of enclosure and inner panel
Plastic bag	1	To protect cover surface and inside gasket
Cardboard corner	4	To reinforced for the plastic strap tightening
Plastic strap - Black	2	To Squeeze 2 cardboard sleeve together
Packaging label	3	White label with PN
Plastic strap- Green	2	To secure the enclosure to the wood pallet
Wood Pallet	1	2" deeper and 3" larger than enclosure size

1	5412DDS606012MF	0	885 MFHD 12" x 12" Mounting Feet
8	STK-Q-07320	0	Flange Lock Nut M10
1	885SP6060G	0	885 SP6060G Inner Panel
1	880INTI	4	880 INTI - Interlock Post Kit
1	880EB14	2	Eye Bolt M14 (Pack of 2)
8	STK-Q-07620	0	M10 Plastic Spacer 0.875"
1	5412DDS606012FD	0	5412DDS 60" x 60" Master Door
1	5412DDS606012LD	0	5412DDS 60" x 60" Slave Door
1	5412DDS606012B	0	5412DDS 60" x 60" x 12" Body
2	5412DDS606012GP	0	5412DDS Gland Plate
8	STK-Q-04050-10	8	M6 x 10mm Hexagon Socket Head Machine Screw with Nyseal
Qty	Part Number	Rev	Description
Parts List			



Tél: (450) 979-4373
Fax: (450) 979-4626
www.exmweb.com

Flatness
Aplatissement
Max 3.0mm

Projection

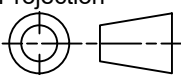

Customer Client		Date
Drawn By Dessiné Par: BoxCad: BoxCad		Date: 18-Sep-14
Material Matière: 12 Ga Cold Rolled A1008 CS Type B (2.5mm)		
Color Couleur: Asa-61 Grey	Finish Fini: Smooth	
Description: 5412DDS 60" x 60" x 12" Assembly		Detail Rev.
Part Number Numéro Pièce: 5412DDS606012		Rev. 0
		2 / 18

This drawing is confidential and must not be reproduced or used without the consent of EXM

Ce dessin est confidentiel et ne doit pas être reproduit ou utilisé sans le consentement de EXM

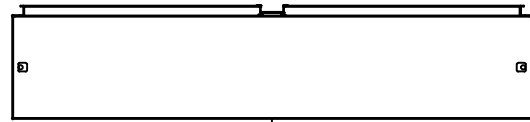

TOP

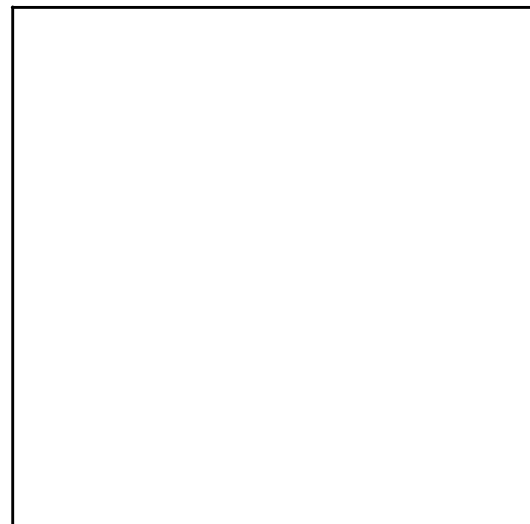

BACK

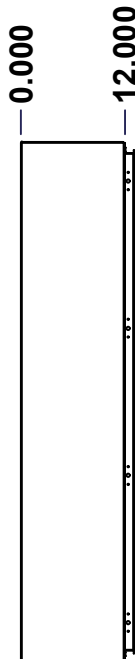

LEFT

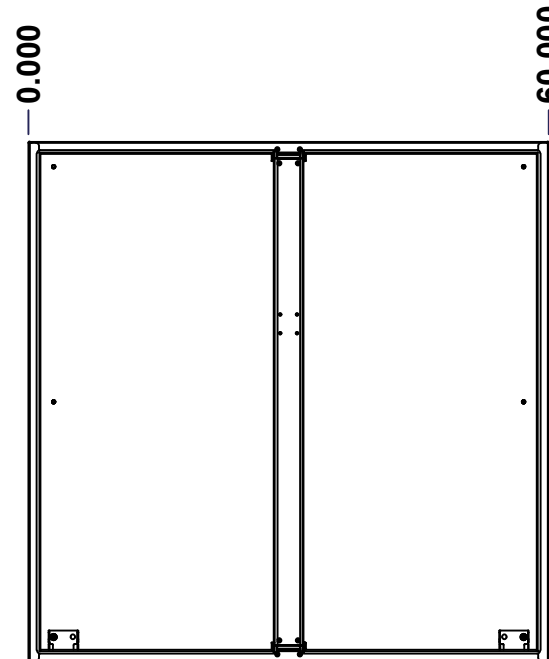

FRONT

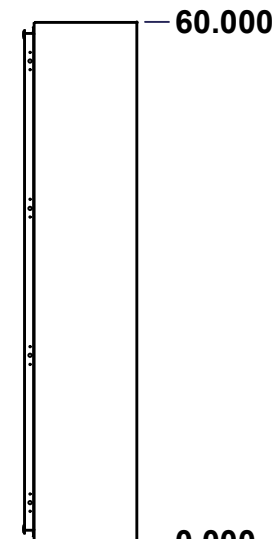

RIGHT



BOTTOM

No.	Revisions	Date	By/Par

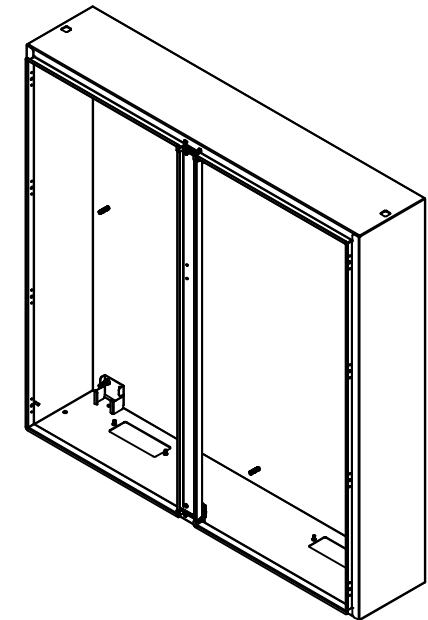

Isometric View



Tél: (450) 979-4373
 Fax: (450) 979-4626
www.exmweb.com

Flatness
Aplatissement

Max 3.0mm

Projection



Customer Client	Date
Drawn By Dessiné Par BoxCad: BoxCad	Date 18-Sep-14
Material Matière 12 Ga Cold Rolled A1008 CS Type B (2.5mm)	
Color Couleur Asa-61 Grey	Finish Fini Smooth
Description 5412DDS 60" x 60" x 12" Body	Detail Rev.
Part Number Numéro Pièce 5412DDS606012B	Rev. 3 0

SEE BILL OF MATERIAL ON LAST PAGE

This drawing is confidential and must not be reproduced or used without the consent of EXM

Ce dessin est confidentiel et ne doit pas être reproduit ou utilisé sans le consentement de EXM

STANDARD FEATURES ARE NOT LISTED IN THIS HOLE TABLE

HOLE TABLE - TOP VIEW (CUSTOM FEATURE ONLY)

CUT-OUT	XDIM	YDIM	DESCRIPTION
1	45.000	8.000	Struts CR400 21.500" (Inside)
2	15.000	8.000	Struts CR400 21.500" (Inside)
3	45.000	8.929	STUDS M6 x 10mm (Inside)
4	55.866	8.000	STUDS M6 x 10mm (Inside)
5	15.000	8.929	STUDS M6 x 10mm (Inside)
6	25.866	8.000	STUDS M6 x 10mm (Inside)

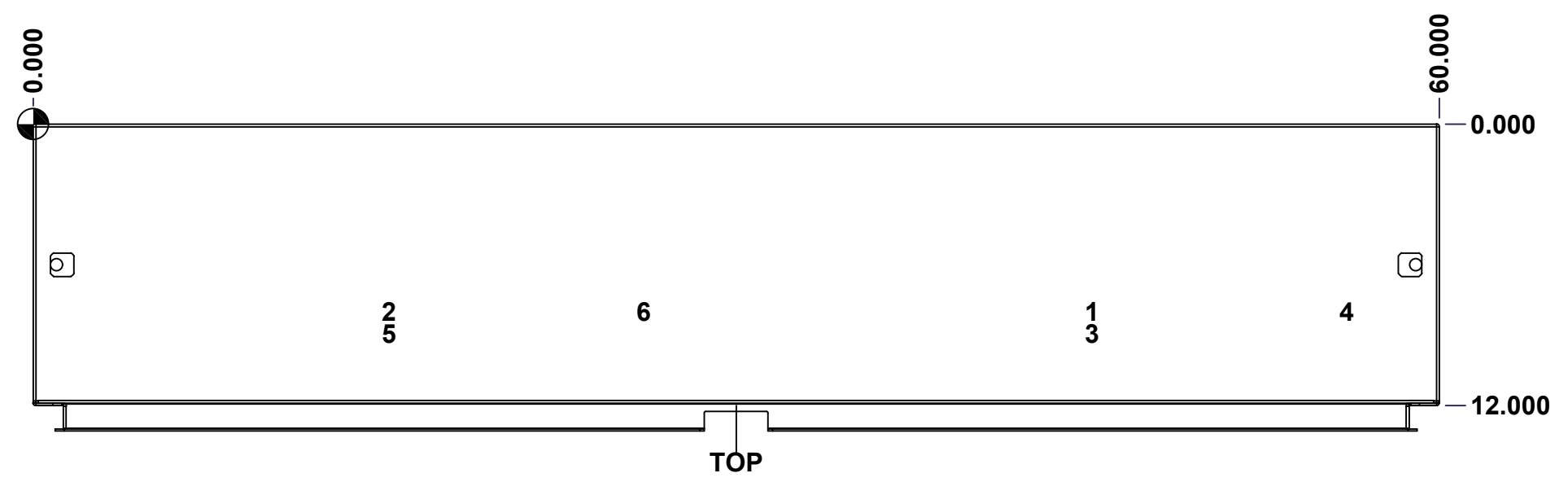

	Description	Status
	5412DDS 60" x 60" x 12" Body	(NULL)
	Part Number Numéro Pièce	Rev.
	5412DDS606012B	0
		4
		18

This drawing is confidential and must not be reproduced or used without the consent of EXM

Ce dessin est confidentiel et ne doit pas être reproduit ou utilisé sans le consentement de EXM

STANDARD FEATURES ARE NOT LISTED IN THIS HOLE TABLE			
HOLE TABLE - RIGHT VIEW (CUSTOM FEATURE ONLY)			
CUT-OUT	XDIM	YDIM	DESCRIPTION
1	10.500	3.375	GND STUD M6 x 16mm (Inside)

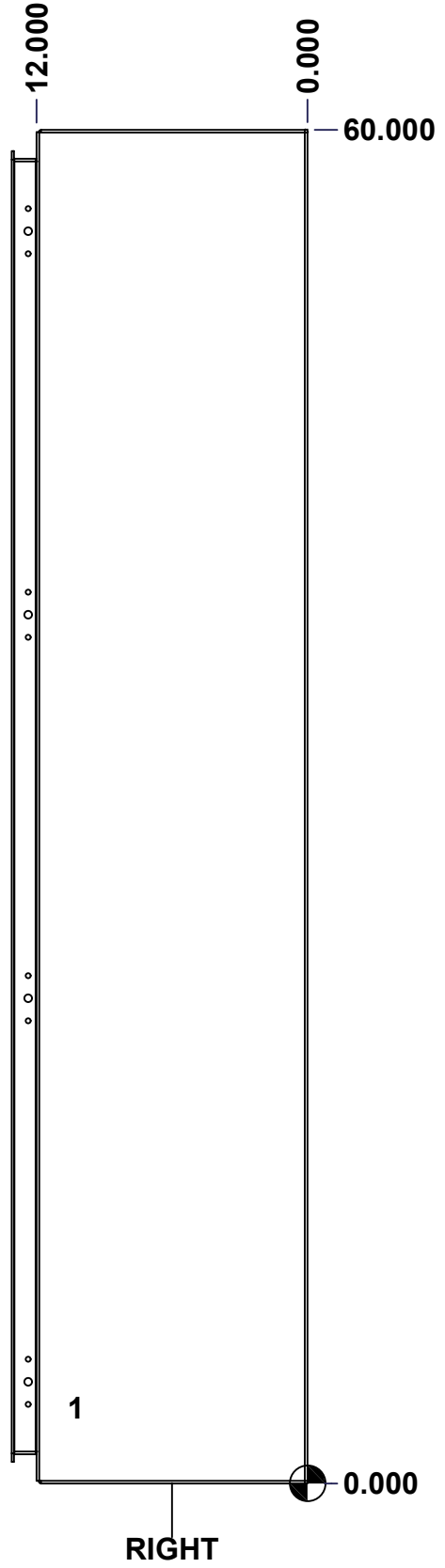

	Description	Status
	5412DDS 60" x 60" x 12" Body	(NULL)
	Part Number Numéro Pièce	Rev.
	5412DDS606012B	0 / 5
		18

This drawing is confidential and must not be reproduced or used without the consent of EXM

Ce dessin est confidentiel et ne doit pas être reproduit ou utilisé sans le consentement de EXM

STANDARD FEATURES ARE NOT LISTED IN THIS HOLE TABLE

HOLE TABLE - BOTTOM VIEW (CUSTOM FEATURE ONLY)

CUT-OUT	XDIM	YDIM	DESCRIPTION
1	7.375	3.500	GP STUD M6 x 16mm (Inside)
2	16.625	3.500	GP STUD M6 x 16mm (Inside)
3	43.375	3.500	GP STUD M6 x 16mm (Inside)
4	52.625	3.500	GP STUD M6 x 16mm (Inside)

5	4.000	1.000	RND Ø0.500
6	1.000	6.000	RND Ø0.500
7	4.000	11.000	RND Ø0.500
8	56.000	1.000	RND Ø0.500
9	59.000	6.000	RND Ø0.500
10	56.000	11.000	RND Ø0.500

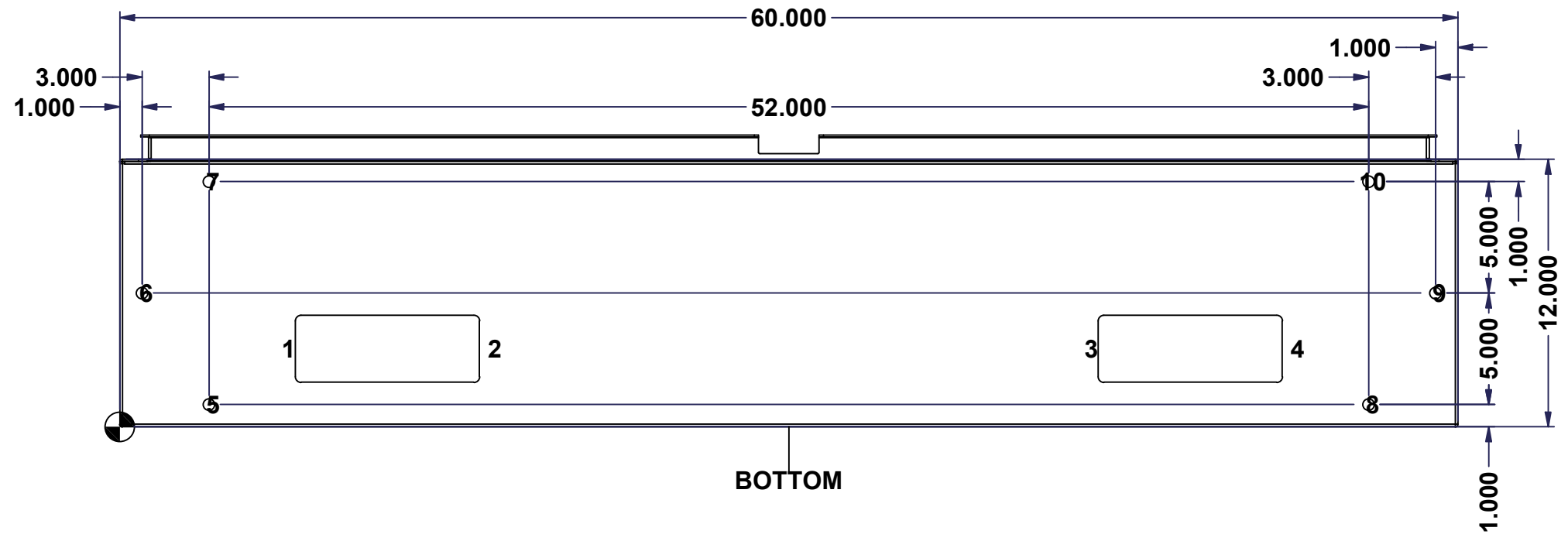

	Description	Status
	5412DDS 60" x 60" x 12" Body	(NULL)
	Part Number Numéro Pièce	Rev.
	5412DDS606012B	0 / 6
		18

This drawing is confidential and must not be reproduced or used without the consent of EXM

Ce dessin est confidentiel et ne doit pas être reproduit ou utilisé sans le consentement de EXM

STANDARD FEATURES ARE NOT LISTED IN THIS HOLE TABLE			
HOLE TABLE - LEFT VIEW (CUSTOM FEATURE ONLY)			
CUT-OUT	XDIM	YDIM	DESCRIPTION
1	10.500	3.375	GND STUD M6 x 16mm (Inside)

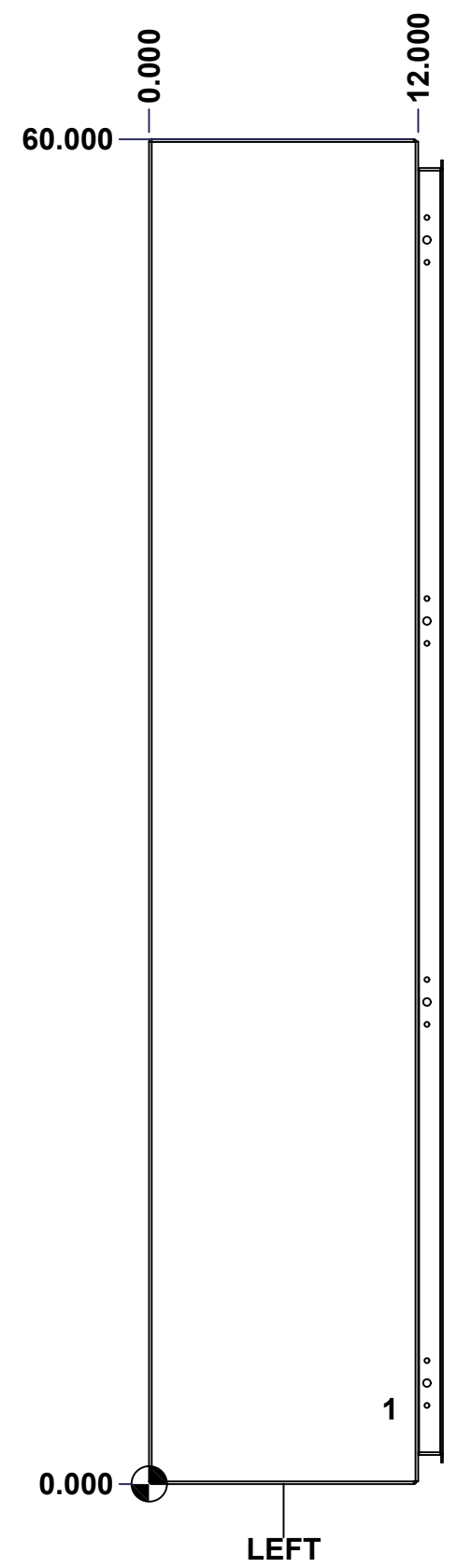

	Description	Status	
	5412DDS 60" x 60" x 12" Body	(NULL)	
	Part Number Numéro Pièce	Rev.	
	5412DDS606012B	0	7 18

This drawing is confidential and must not be reproduced or used without the consent of EXM

Ce dessin est confidentiel et ne doit pas être reproduit ou utilisé sans le consentement de EXM

STANDARD FEATURES ARE NOT LISTED IN THIS HOLE TABLE

HOLE TABLE - BACK VIEW (CUSTOM FEATURE ONLY)

CUT-OUT	XDIM	YDIM	DESCRIPTION
1	2.875	2.875	IP STUD M10 x 40mm (Inside)
2	57.125	2.875	IP STUD M10 x 40mm (Inside)
3	2.875	30.000	IP STUD M10 x 40mm (Inside)
4	57.125	30.000	IP STUD M10 x 40mm (Inside)
5	2.875	57.125	IP STUD M10 x 40mm (Inside)
6	57.125	57.125	IP STUD M10 x 40mm (Inside)
7	30.000	2.875	IP STUD M10 x 40mm (Inside)
8	30.000	57.125	IP STUD M10 x 40mm (Inside)

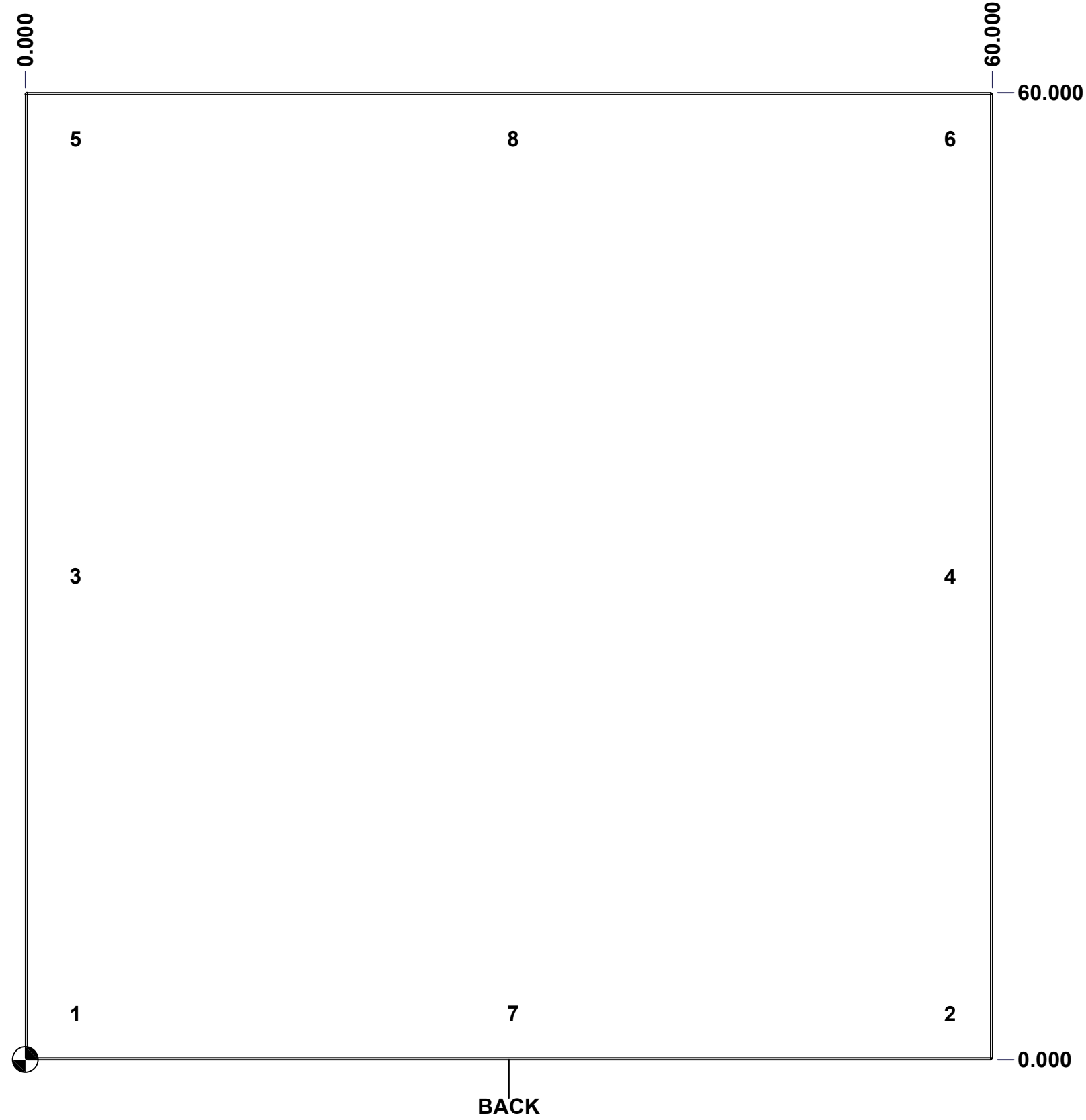

	Description	Status
	5412DDS 60" x 60" x 12" Body	(NULL)
	Part Number Numéro Pièce	Rev.
	5412DDS606012B	0 / 8
		18

This drawing is confidential and must not be reproduced or used without the consent of EXM

Ce dessin est confidentiel et ne doit pas être reproduit ou utilisé sans le consentement de EXM

STANDARD FEATURES ARE NOT LISTED IN THIS HOLE TABLE

HOLE TABLE - CENTER VIEW (CUSTOM FEATURE ONLY)

CUT-OUT	XDIM	YDIM	DESCRIPTION
1	0.748	36.220	PEM FH-M6-15ZI (Inside)
2	0.748	38.346	PEM FH-M6-15ZI (Inside)
3	2.717	36.220	PEM FH-M6-15ZI (Inside)
4	2.717	38.346	PEM FH-M6-15ZI (Inside)

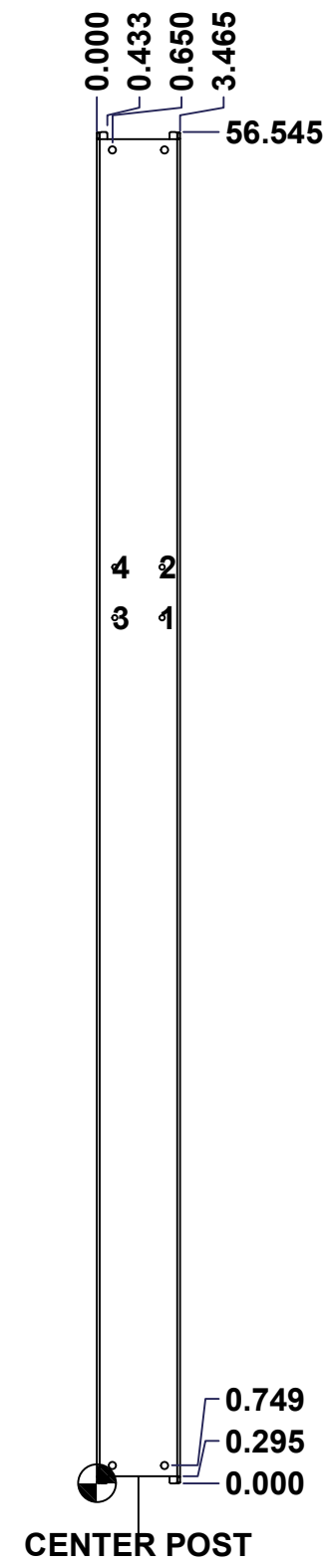

	Description	Status
	5412DDS 60" x 60" x 12" Body	(NULL)
Part Number Numéro Pièce 5412DDS606012B	Rev.	9
	0	18

This drawing is confidential and must not be reproduced or used without the consent of EXM

Ce dessin est confidentiel et ne doit pas être reproduit ou utilisé sans le consentement de EXM

No.	Revisions	Date	By/Par

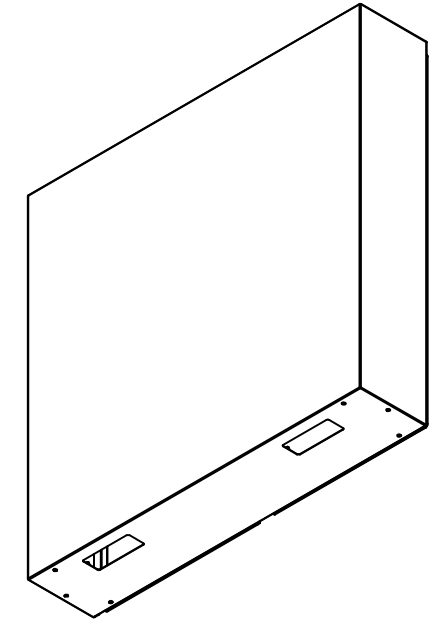

Isometric View

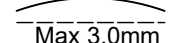
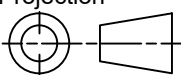

Qty	Part Number	Rev	Description
4	STK-Q-16030	0	Stud M6 x 10mm Steel
4	STK-PEM-FH-M6-15ZI	0	PEM Self-Clinching Stud M6 x 15.0mm
1	STK-P-02400S	0	Powder Paint (Asa-61 Grey / Smooth)
2	STK-Q-74900	0	Eyebolt Lifting Angle (8.750")
1	STK-A-75454	3	Center Post - Sealing Block with Latch Assembly (Large)
1	5412DDS606012CP-P	0	5412DDS 60" Center Post Part
2	STK-Q-07320	0	Flange Lock Nut M10
2	STK-Q-07618	1	5500 Series Inner Panel Support Bracket
8	STK-Q-16100	0	Stud M10 x 40mm Steel
1	5412DDS606012B-P	0	5412DDS 60" x 60" Body Part
2	5412DDS606012_CR400 MS_21.5	0	Commercial Roll Mild Steel (21.5in long)
6	STK-Q-16080	0	Ground Stud M6 x 16mm Steel
Qty	Part Number	Rev	Description
Parts List			

 Tél: (450) 979-4373 Fax: (450) 979-4626 www.exmweb.com		Flatness Aplatissement  Max 3.0mm
Projection 		Customer Client Date
Drawn By Dessiné Par BoxCad: BoxCad		Date 18-Sep-14
Material Matière 12 Ga Cold Rolled A1008 CS Type B (2.5mm)		
Color Couleur Asa-61 Grey	Finish Fini Smooth	
Description 5412DDS 60" x 60" x 12" Body		Detail Rev.
Part Number Numéro Pièce 5412DDS606012B		Rev. 10 0 18

This drawing is confidential and must not be reproduced or used without the consent of EXM

Ce dessin est confidentiel et ne doit pas être reproduit ou utilisé sans le consentement de EXM

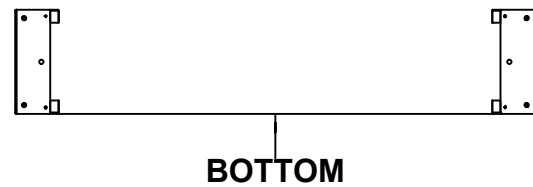
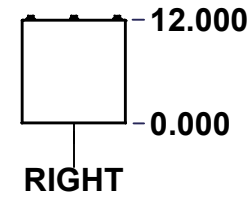
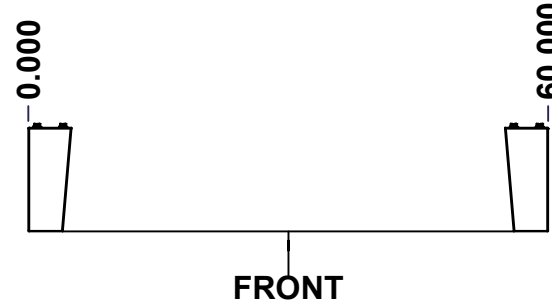
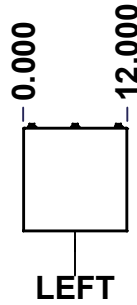
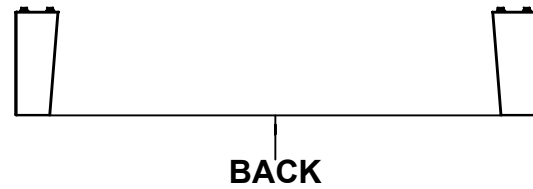
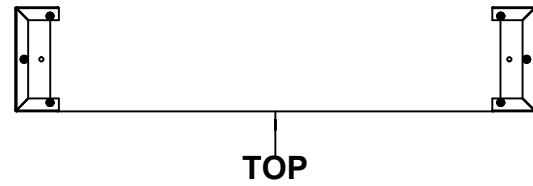

No.	Revisions	Date	By/Par

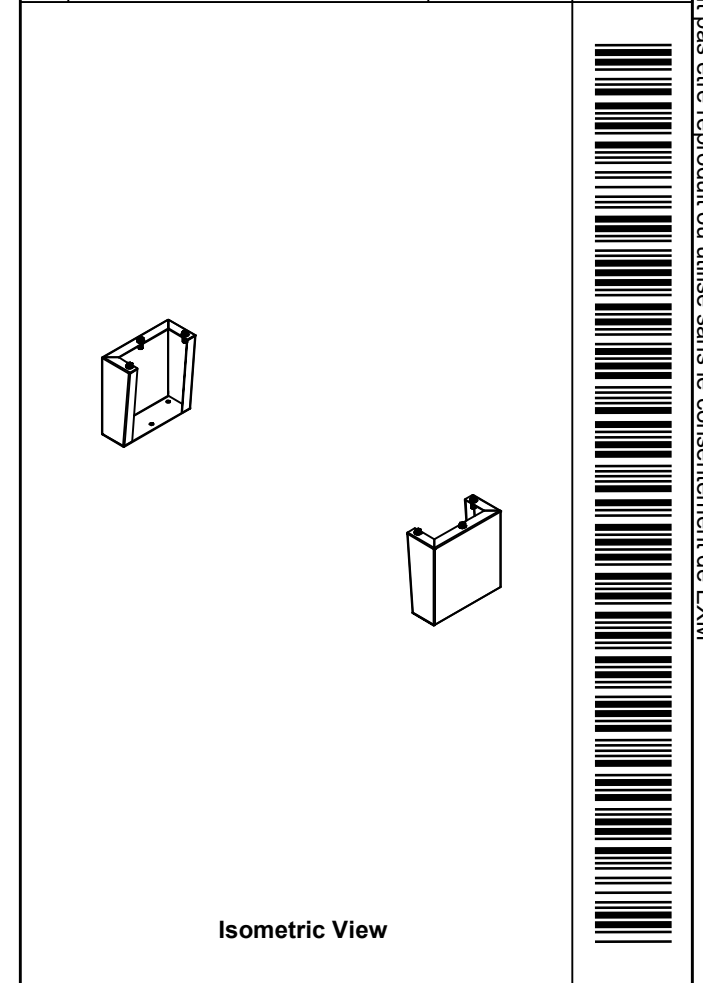

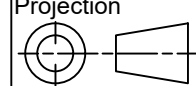
 Tél: (450) 979-4373 Fax: (450) 979-4626 www.exmweb.com		Flatness Aplatissement Max 3.0mm Projection 
Customer Client	Date	
Drawn By Dessiné Par	BoxCad: BoxCad	Date 18-Sep-14
Material Matière	12 Ga Cold Rolled A1008 CS Type B (2.5mm)	
Color Couleur	Asa-61 Grey	Finish Fini Smooth
Description 885 MFHD 12" x 12" Mounting Feet		Detail Rev.
Part Number Numéro Pièce	Rev. 0	11 18

SEE BILL OF MATERIAL ON LAST PAGE

5412DDS606012MF

This drawing is confidential and must not be reproduced or used without the consent of EXM

Ce dessin est confidentiel et ne doit pas être reproduit ou utilisé sans le consentement de EXM

No.	Revisions	Date	By/Par

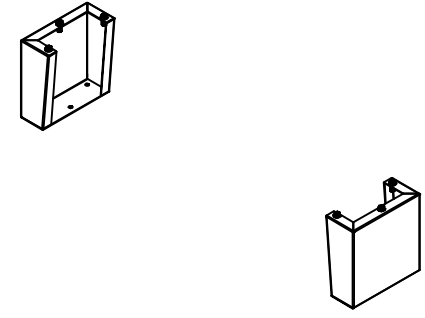

Isometric View



Tél: (450) 979-4373
 Fax: (450) 979-4626
www.exmweb.com

Flatness
Aplatissement
Max 3.0mm
Projection

Customer Client	Date
Drawn By / Dessiné Par: BoxCad: BoxCad	Date: 18-Sep-14
Material / Matière: 12 Ga Cold Rolled A1008 CS Type B (2.5mm)	

Color / Couleur: Asa-61 Grey	Finish / Fini: Smooth
------------------------------	-----------------------

Description: 885 MFHD 12" x 12" Mounting Feet	Detail Rev.
---	-------------

Part Number / Numéro Pièce: 5412DDS606012MF	Rev. 0	12 / 18
--	--------	---------

Qty	Part Name	Rev	Description
1	STK-P-02400S	0	Powder Paint (Asa-61 Grey / Smooth)
6	RIVET_NUT_M10_FH_CE	0	Rivet Nut M10 (Low Profile Close End)
1	5412DDS606012MFR-P	0	885 MFHD 12" x 12" Right Mounting Feet Part
1	5412DDS606012MFL-P	0	885 MFHD 12" x 12" Left Mounting Feet Part
3	STK-K-11600	2	885 MF Accessory Kit
Parts List			

This drawing is confidential and must not be reproduced or used without the consent of EXM

Ce dessin est confidentiel et ne doit pas être reproduit ou utilisé sans le consentement de EXM

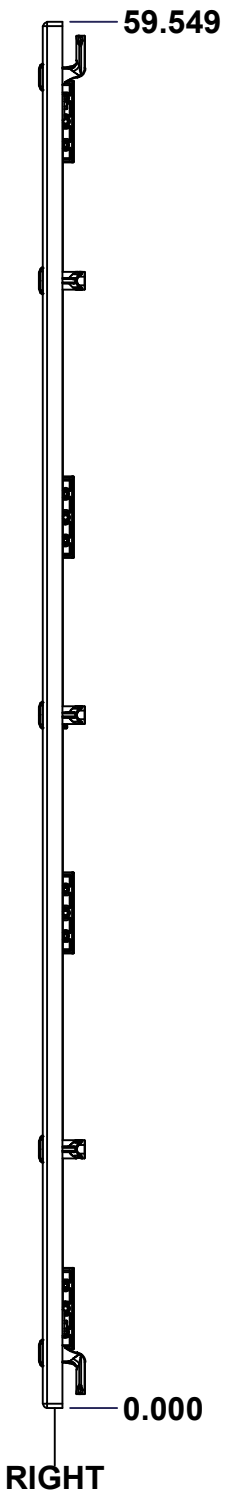
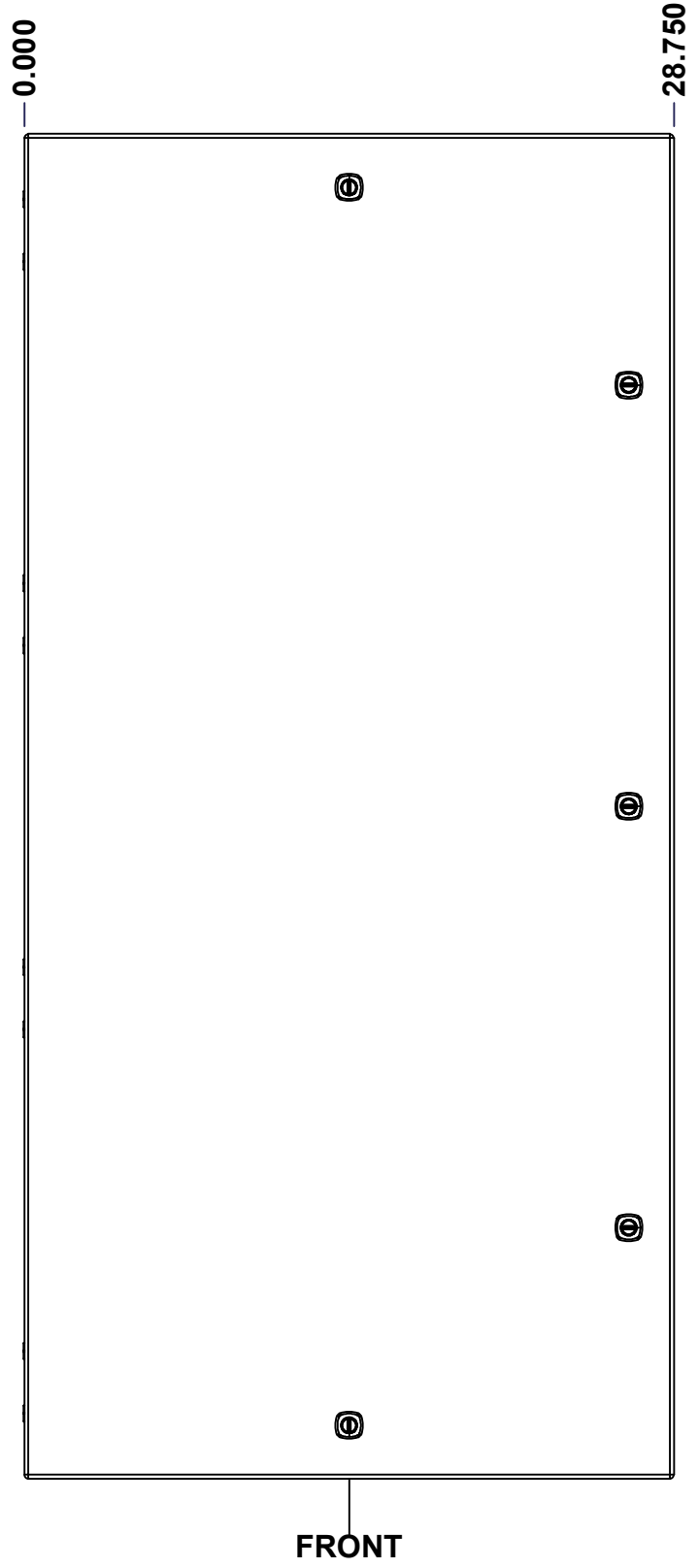
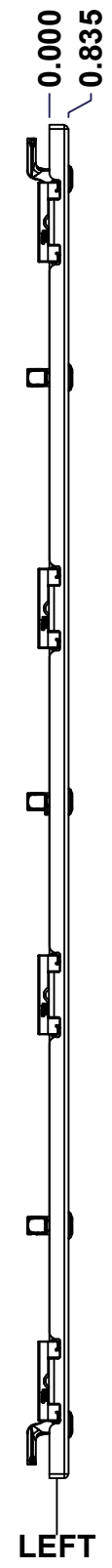
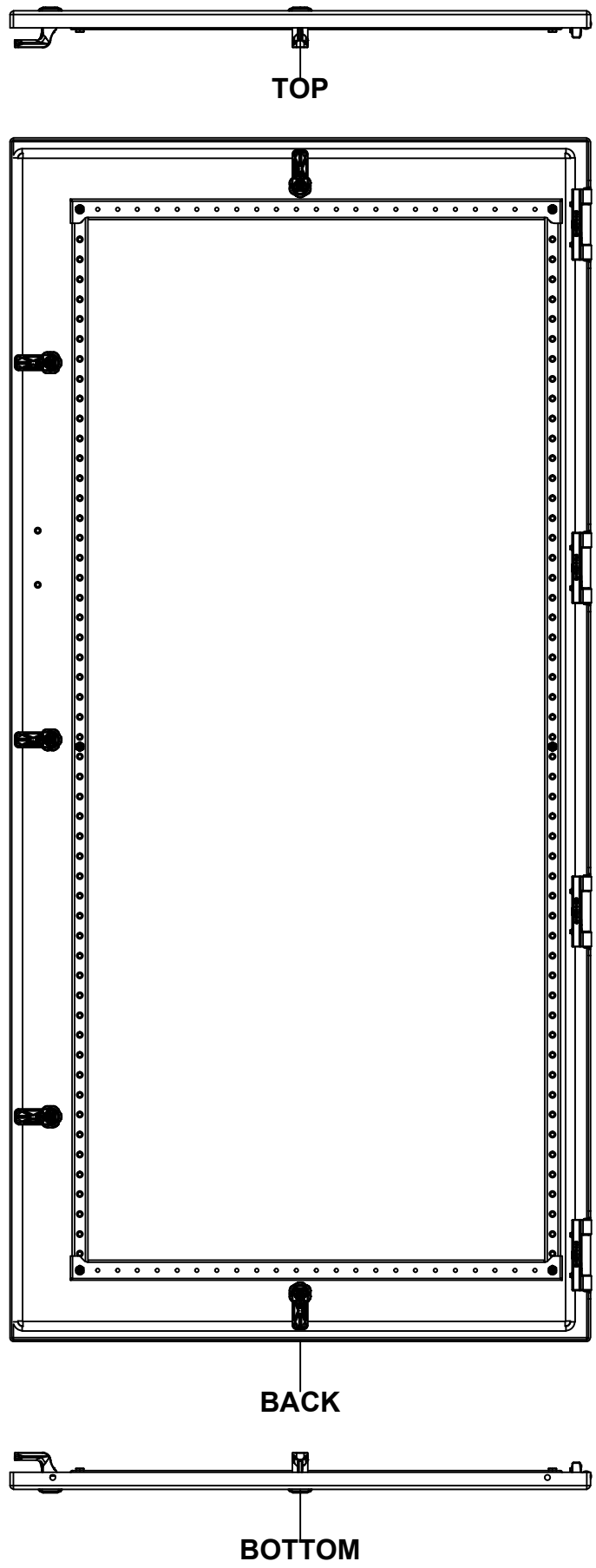

No.	Revisions	Date	By/Par

Isometric View of the door showing its 3D structure and locking mechanism.

Tél: (450) 979-4373 Fax: (450) 979-4626 www.exmweb.com		Flatness Aplatissement Max 3.0mm Projection
Customer Client	Date	
Drawn By Dessiné Par	BoxCad: BoxCad	Date 18-Sep-14
Material Matière	12 Ga Cold Rolled A1008 CS Type B (2.5mm)	
Color Couleur	Asa-61 Grey	Finish Fini Smooth
Description	Detail Rev.	
5412DDS 60" x 60" Slave Door		
Part Number Numéro Pièce	Rev. 0	13 / 18

SEE BILL OF MATERIAL ON LAST PAGE

5412DDS606012LD

This drawing is confidential and must not be reproduced or used without the consent of EXM

Ce dessin est confidentiel et ne doit pas être reproduit ou utilisé sans le consentement de EXM

STANDARD FEATURES ARE NOT LISTED IN THIS HOLE TABLE

HOLE TABLE - FRONT VIEW (CUSTOM FEATURE ONLY)

CUT-OUT	XDIM	YDIM	DESCRIPTION
1	1.875	3.524	STUD M6 x 18mm (Inside)
2	1.875	29.430	STUD M6 x 18mm (Inside)
3	1.875	56.024	STUD M6 x 18mm (Inside)
4	25.282	3.524	STUD M6 x 18mm (Inside)
5	25.282	29.430	STUD M6 x 18mm (Inside)
6	25.282	56.024	STUD M6 x 18mm (Inside)
-----	-----	-----	-----
7	26.750	48.430	LOCK 889 SCQ4-SL @ 0.0°
8	26.750	29.774	LOCK 889 SCQ4-SL @ 0.0°
9	14.375	2.368	LOCK 889 SCQ4-SL @ 270.0°
10	26.750	11.118	LOCK 889 SCQ4-SL @ 0.0°
11	14.375	57.180	LOCK 889 SCQ4-SL @ 90.0°
12	27.372	37.445	STUDS M6 x 18mm (Inside)
13	27.372	40.123	STUDS M6 x 18mm (Inside)

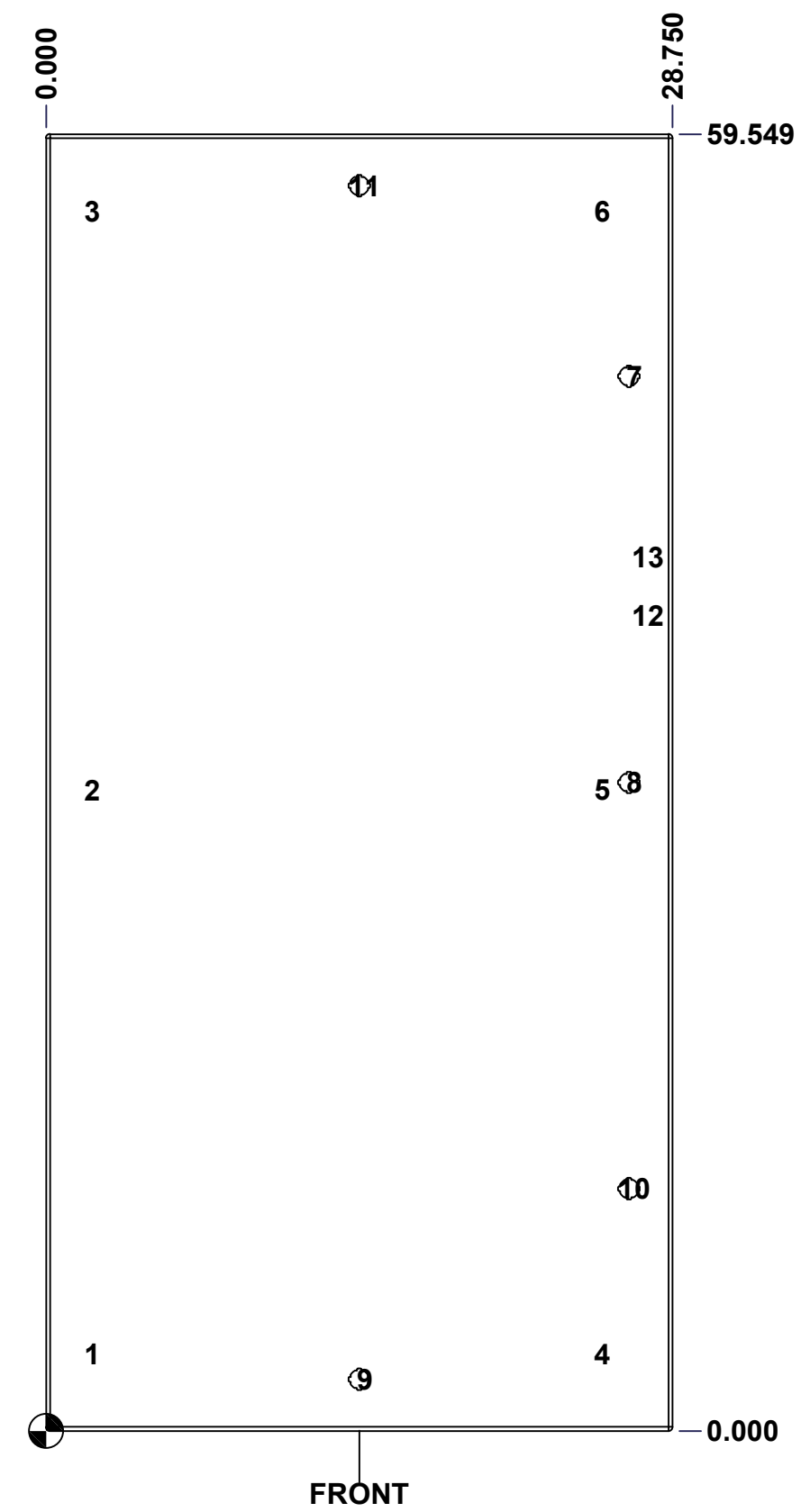

	Description	Status
	5412DDS 60" x 60" Slave Door	(NULL)
	Part Number Numéro Pièce	Rev.
	5412DDS606012LD	0 / 14
		18

This drawing is confidential and must not be reproduced or used without the consent of EXM

Ce dessin est confidentiel et ne doit pas être reproduit ou utilisé sans le consentement de EXM

No.	Revisions	Date	By/Par

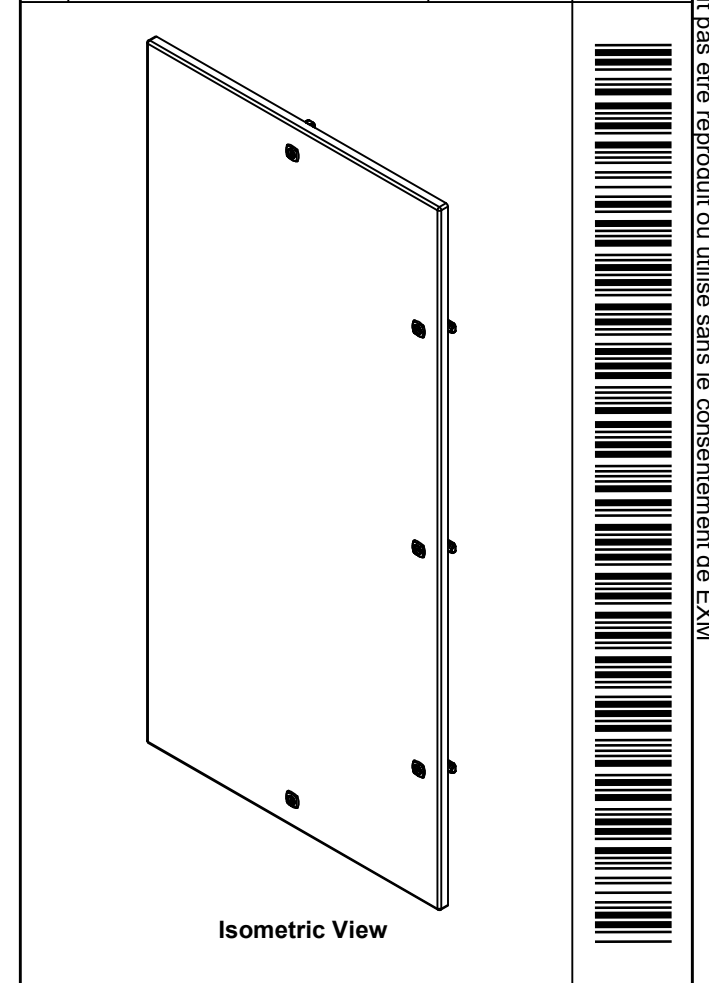

EXM
www.exmweb.com

Tél: (450) 979-4373
Fax: (450) 979-4626

Flatness
Aplatissement
Max 3.0mm

Projection

Customer Client _____ Date _____

Drawn By / Dessiné Par BoxCad: BoxCad Date 18-Sep-14

Material / Matière 12 Ga Cold Rolled A1008 CS Type B (2.5mm)

Color / Couleur Asa-61 Grey Finish / Fini Smooth

Description 5412DDS 60" x 60" Slave Door Detail Rev. _____

Part Number / Numéro Pièce **5412DDS606012LD** Rev. **0** 15 / 18

QTY	Part Number	Rev	Description
2	STK-Q-16050	1	Stud M6 x 18mm Steel
1	STK-P-02400S	0	Powder Paint (Asa-61 Grey / Smooth)
1	5412DDS606012DS1	0	5412DDS 60" x 60" Door Stiffener
6	STK-Q-16055	1	M6 x 18mm Stud (No Paint Cap Required)
1	5412DDS606012DG	0	5412DDS 60" x 60" Door Gasket
1	5412DDS606012LD-P	0	5412DDS 60" x 60" Slave Door Part
4	STK-K-09860	7	Cabinet Hinge with Captive Pins
5	STK-K-12580	0	9412 1/4 Turn Lock
Parts List			

This drawing is confidential and must not be reproduced or used without the consent of EXM

Ce dessin est confidentiel et ne doit pas être reproduit ou utilisé sans le consentement de EXM

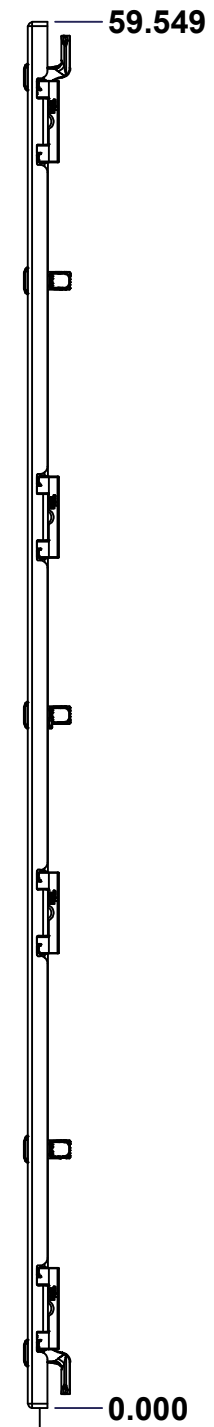
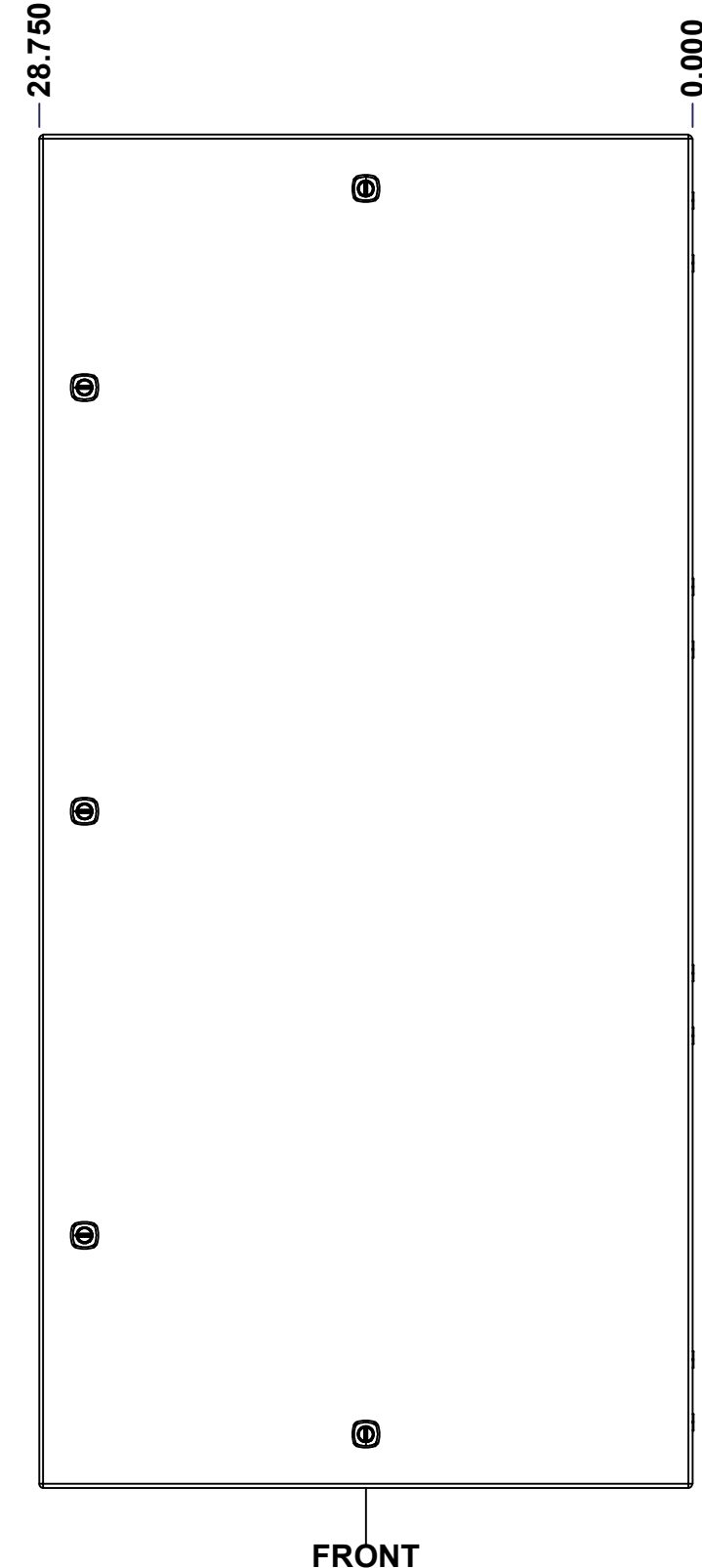
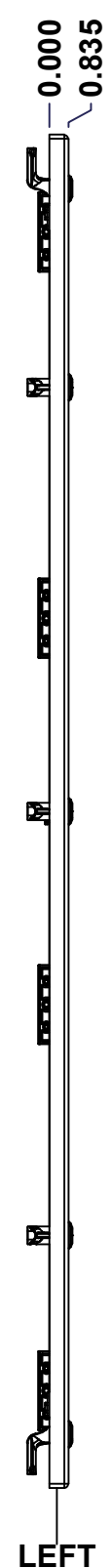
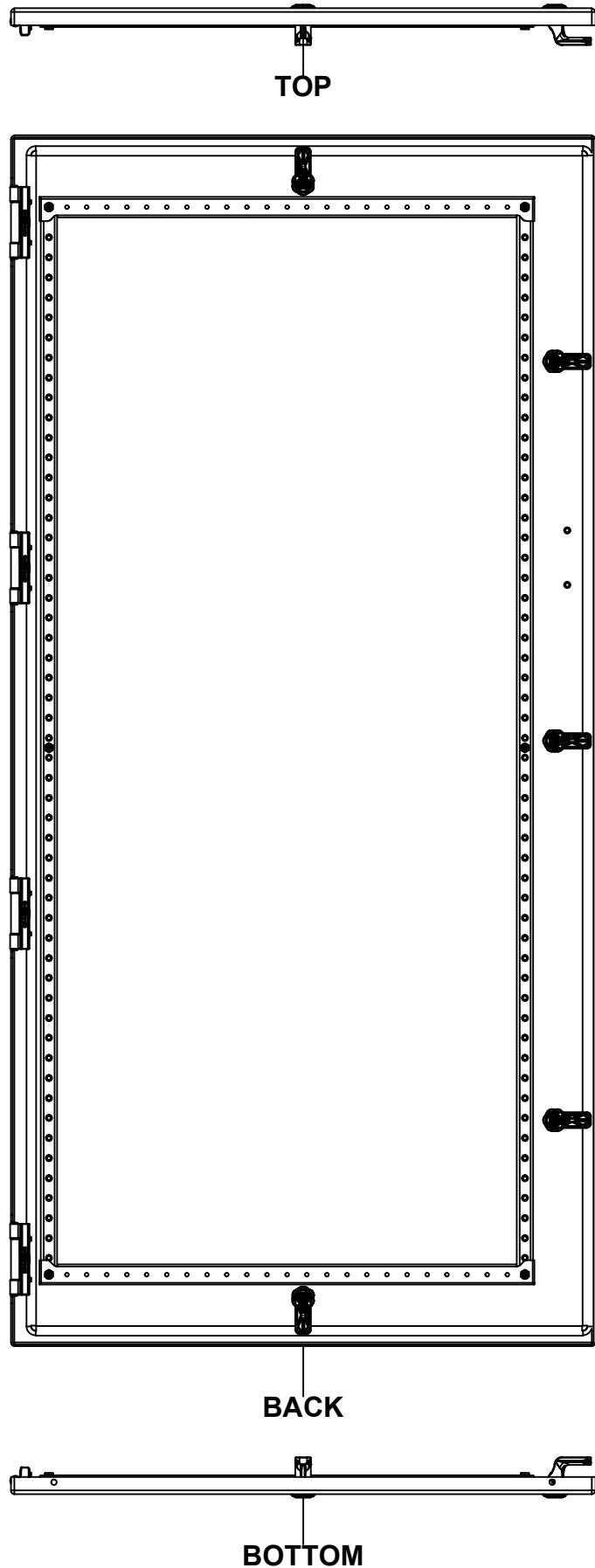

No.	Revisions	Date	By/Par

Isometric View

Tél: (450) 979-4373 Fax: (450) 979-4626 www.exmweb.com		Flatness Aplatissement
		Max 3.0mm
Customer Client		Date
Drawn By Dessiné Par BoxCad: BoxCad		Date 18-Sep-14
Material Matière 12 Ga Cold Rolled A1008 CS Type B (2.5mm)		
Color Couleur	Asa-61 Grey	Finish Fini Smooth
Description		Detail Rev.
5412DDS 60" x 60" Master Door		
Part Number Numéro Pièce		Rev. 16
5412DDS606012FD		0 18

SEE BILL OF MATERIAL ON LAST PAGE

This drawing is confidential and must not be reproduced or used without the consent of EXM

Ce dessin est confidentiel et ne doit pas être reproduit ou utilisé sans le consentement de EXM

STANDARD FEATURES ARE NOT LISTED IN THIS HOLE TABLE

HOLE TABLE - FRONT VIEW (CUSTOM FEATURE ONLY)

CUT-OUT	XDIM	YDIM	DESCRIPTION
1	1.875	3.524	STUD M6 x 18mm (Inside)
2	1.875	29.430	STUD M6 x 18mm (Inside)
3	1.875	56.024	STUD M6 x 18mm (Inside)
4	25.282	3.524	STUD M6 x 18mm (Inside)
5	25.282	29.430	STUD M6 x 18mm (Inside)
6	25.282	56.024	STUD M6 x 18mm (Inside)

7	26.750	48.430	LOCK 889 SCQ4-SL @ 180.0°
8	26.750	29.774	LOCK 889 SCQ4-SL @ 180.0°
9	26.750	11.118	LOCK 889 SCQ4-SL @ 180.0°
10	14.375	57.180	LOCK 889 SCQ4-SL @ 90.0°
11	14.375	2.368	LOCK 889 SCQ4-SL @ 270.0°
12	27.372	37.445	STUDS M6 x 18mm (Inside)
13	27.372	40.123	STUDS M6 x 18mm (Inside)

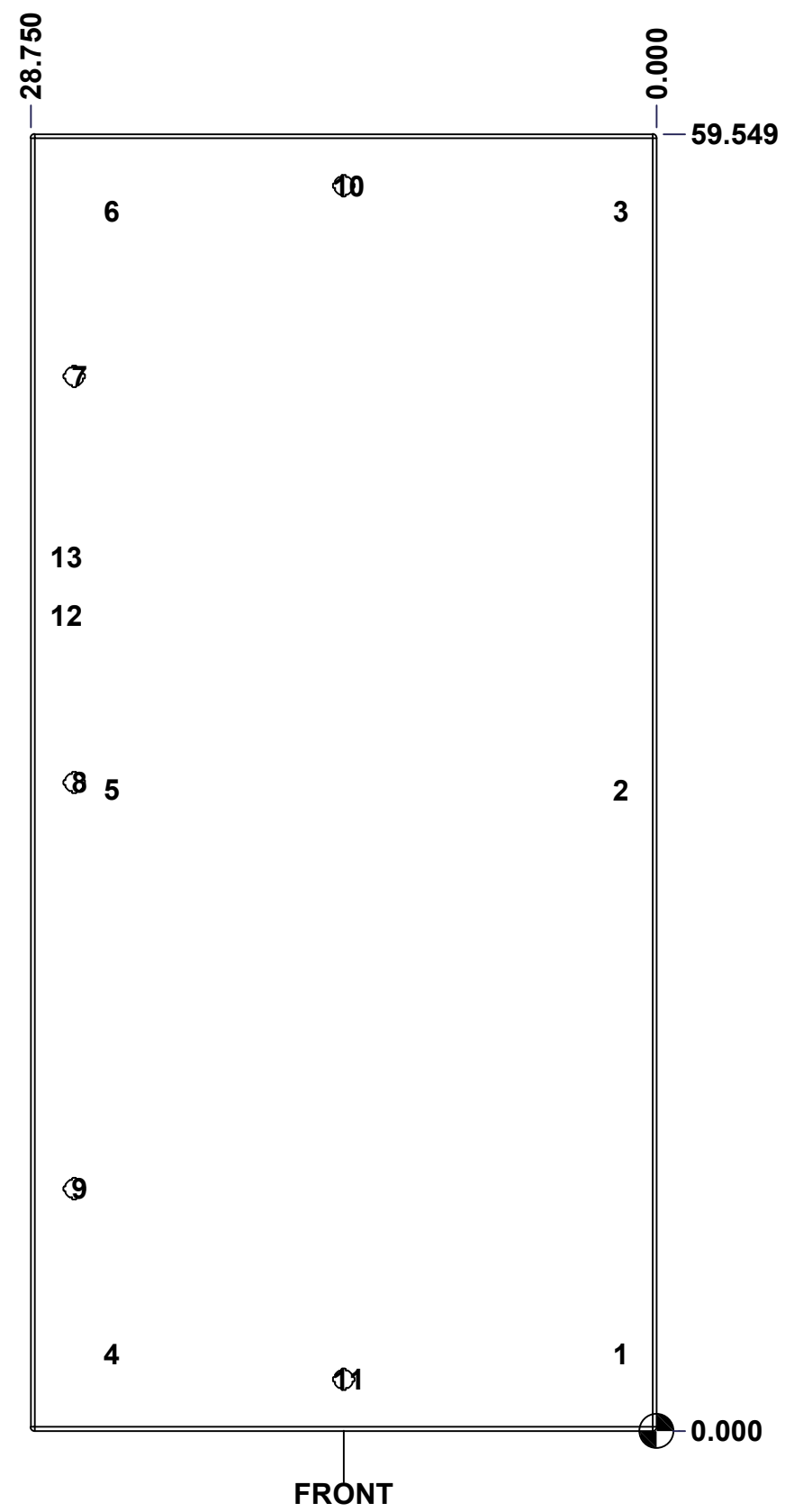

	Description	Status
	5412DDS 60" x 60" Master Door	(NULL)
	Part Number Numéro Pièce	Rev.
	5412DDS606012FD	0 / 17
		18

This drawing is confidential and must not be reproduced or used without the consent of EXM

Ce dessin est confidentiel et ne doit pas être reproduit ou utilisé sans le consentement de EXM

No.	Revisions	Date	By/Par

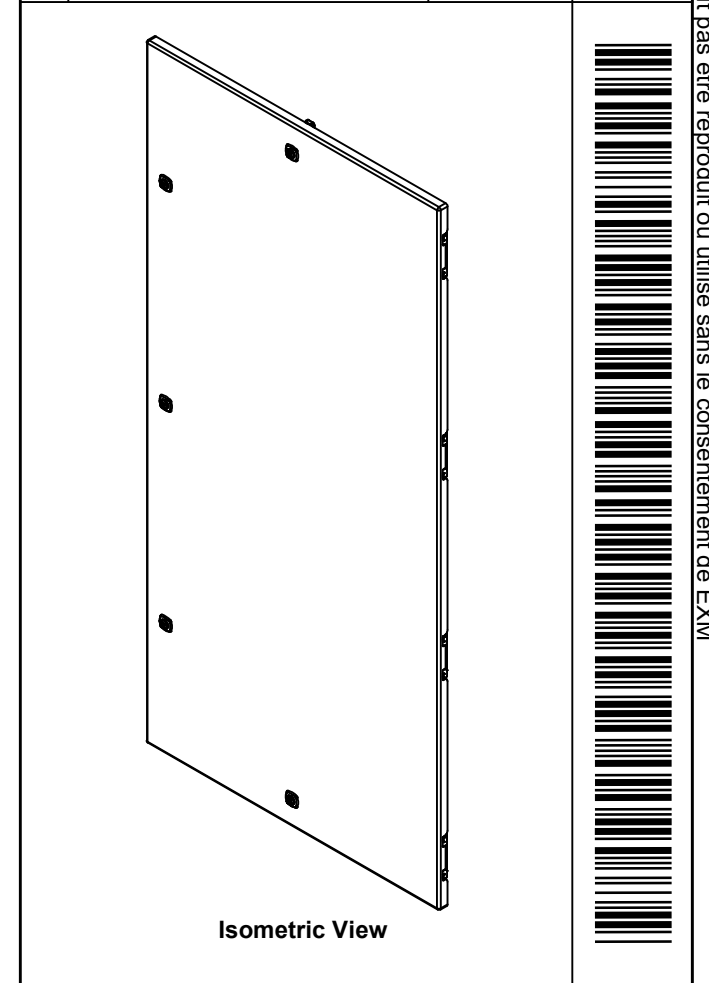

EXM
www.exmweb.com

Tél: (450) 979-4373
Fax: (450) 979-4626

Flatness
Aplatissement
Max 3.0mm

Projection

Customer Client _____ Date _____

Drawn By Dessiné Par BoxCad: BoxCad Date 18-Sep-14

Material Matière 12 Ga Cold Rolled A1008 CS Type B (2.5mm)

Color Couleur Asa-61 Grey Finish Fini Smooth

Description 5412DDS 60" x 60" Master Door

Detail Rev. _____

Part Number Numéro Pièce **5412DDS606012FD**

Rev. 0

18 / 18

QTY	Part Number	Rev	Description
2	STK-Q-16050	1	Stud M6 x 18mm Steel
1	STK-P-02400S	0	Powder Paint (Asa-61 Grey / Smooth)
1	5412DDS606012DS1	0	5412DDS 60" x 60" Door Stiffener
6	STK-Q-16055	1	M6 x 18mm Stud (No Paint Cap Required)
1	5412DDS606012DG	0	5412DDS 60" x 60" Door Gasket
1	5412DDS606012FD-P	0	5412DDS 60" x 60" Master Door Part
4	STK-K-09860	7	Cabinet Hinge with Captive Pins
5	STK-K-12580	0	9412 1/4 Turn Lock
Parts List			

This drawing is confidential and must not be reproduced or used without the consent of EXM

Ce dessin est confidentiel et ne doit pas être reproduit ou utilisé sans le consentement de EXM

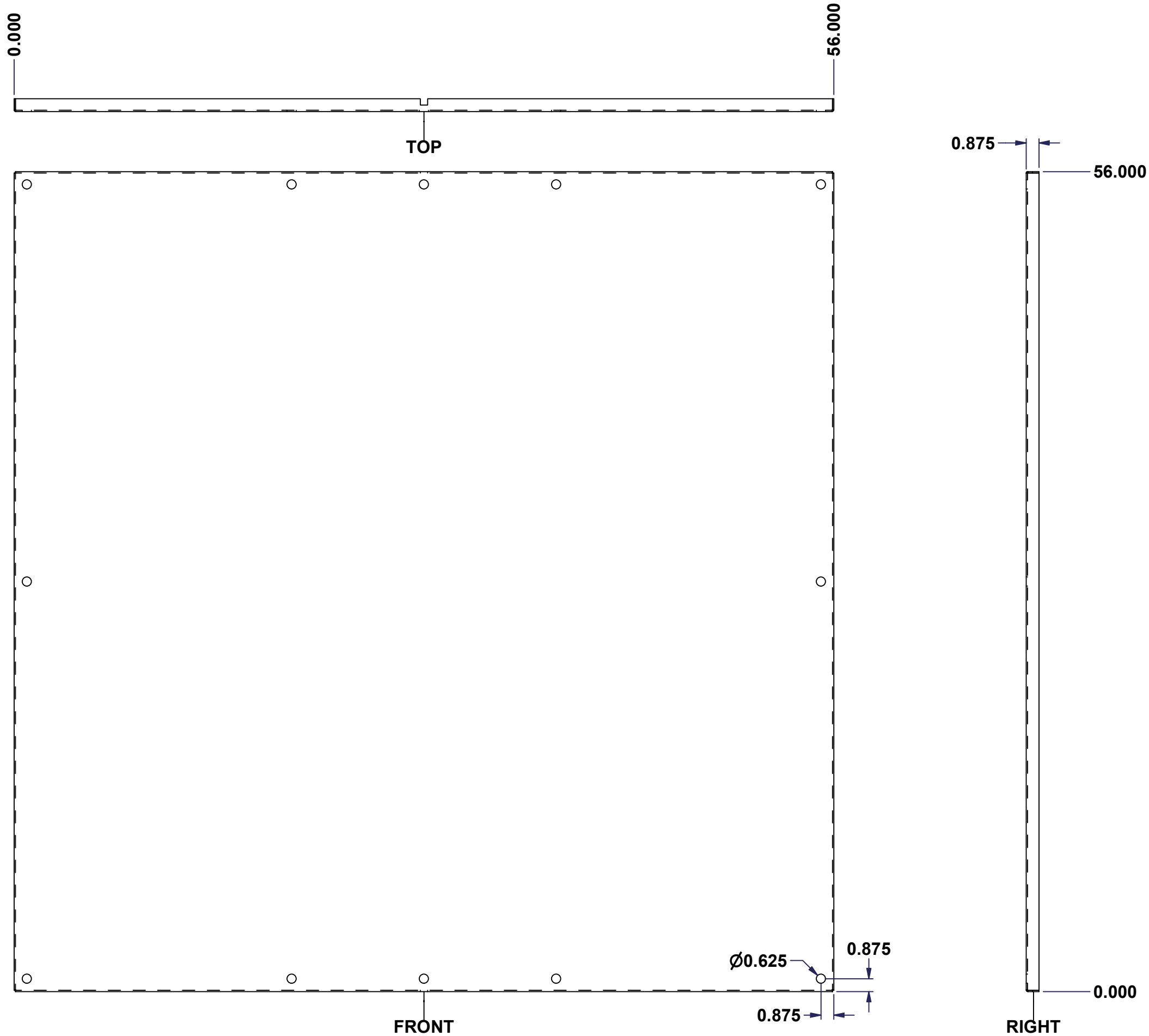

SEE BILL OF MATERIAL ON LAST PAGE

No.	Revisions	Date	By/Par

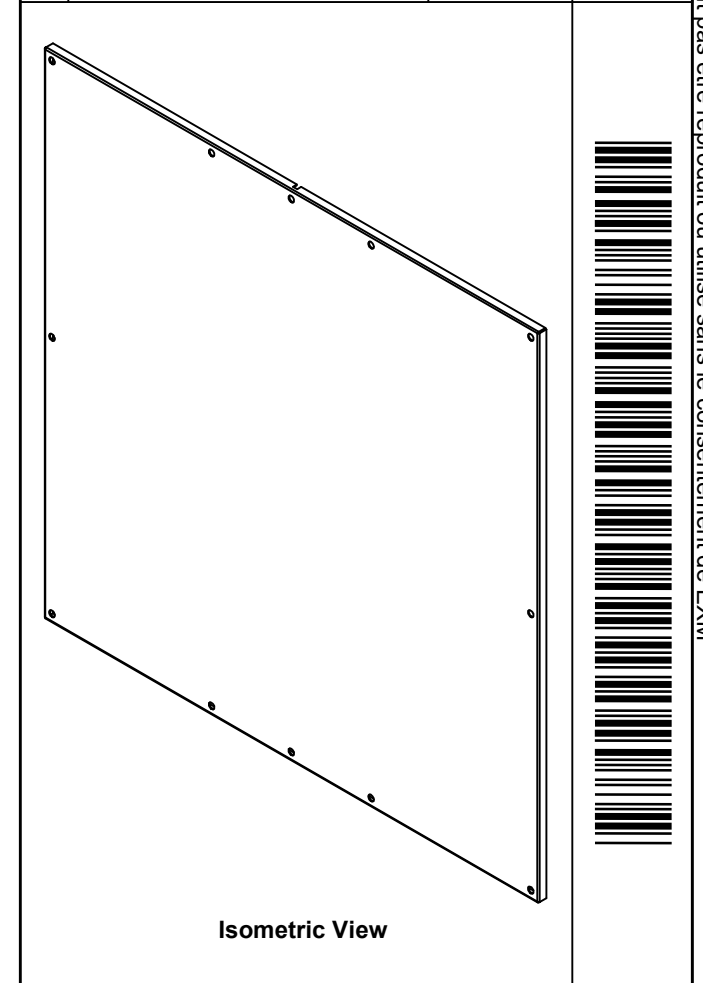

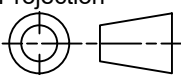

 Tél: (450) 979-4373 Fax: (450) 979-4626 www.exmweb.com		Flatness Aplatissement Max 3.0mm
Projection 		Date
Customer Client		Date 04/11/2009
Drawn By / Dessiné Par	BoxCad	
Material / Matière	12 Ga Galvanized (2.5mm)	
Color / Couleur	Unpainted	Finish / Fini: Unpainted
Description	885 SP6060G Inner Panel	
Part Number / Numéro Pièce	885SP6060G	Detail Rev.
	Rev. 0	1 / 2

This drawing is confidential and must not be reproduced or used without the consent of EXM

Ce dessin est confidentiel et ne doit pas être reproduit ou utilisé sans le consentement de EXM

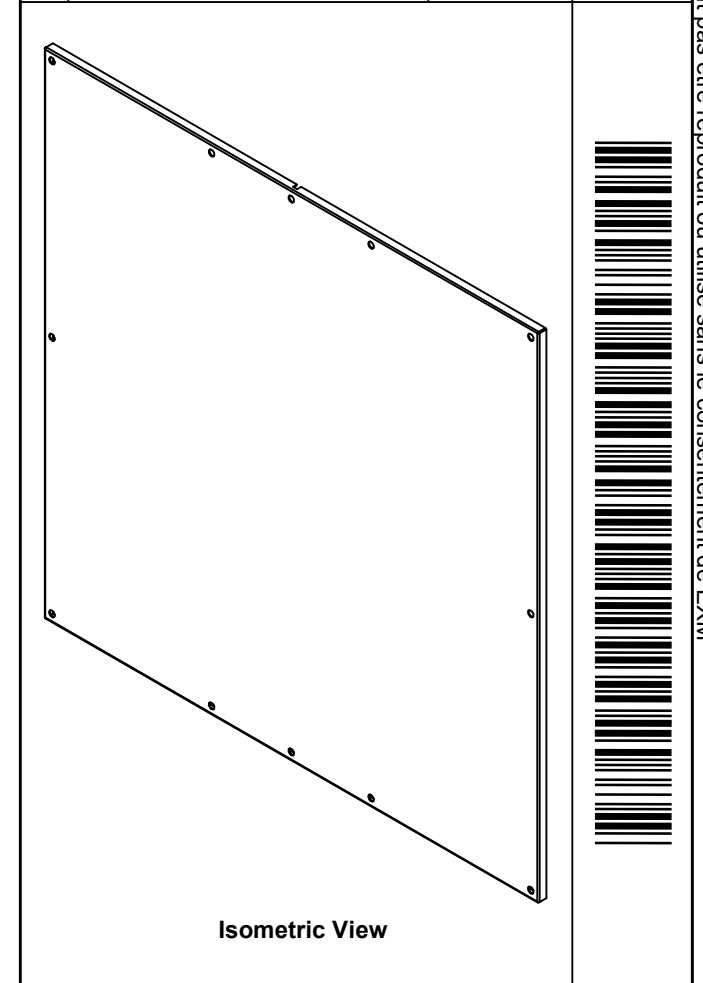
No.	Revisions	Date	By/Par

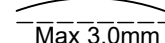

 Tél: (450) 979-4373 Fax: (450) 979-4626 www.exmweb.com		Flatness Aplatissement  Max 3.0mm
Customer Client		Date
Drawn By / Dessiné Par: BoxCad		Date: 04/11/2009
Material / Matière: 12 Ga Galvanized (2.5mm)		
Color / Couleur: Unpainted	Finish / Fini: Unpainted	
Description: 885 SP6060G Inner Panel		Detail Rev.
Part Number / Numéro Pièce: 885SP6060G		Rev. 0 / 2

Qty	Part Number	Rev	Description
1	885SP6060G-P	0	885 SP6060G Inner Panel Part
Parts List			