

This drawing is confidential and must not be reproduced or used without the consent of EXM

Ce dessin est confidentiel et ne doit pas être reproduit ou utilisé sans le consentement de EXM

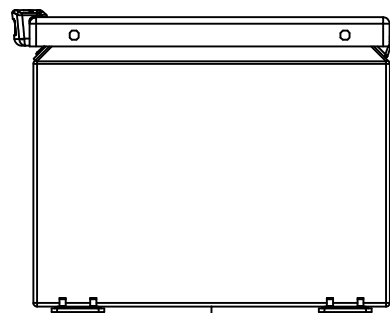

TOP

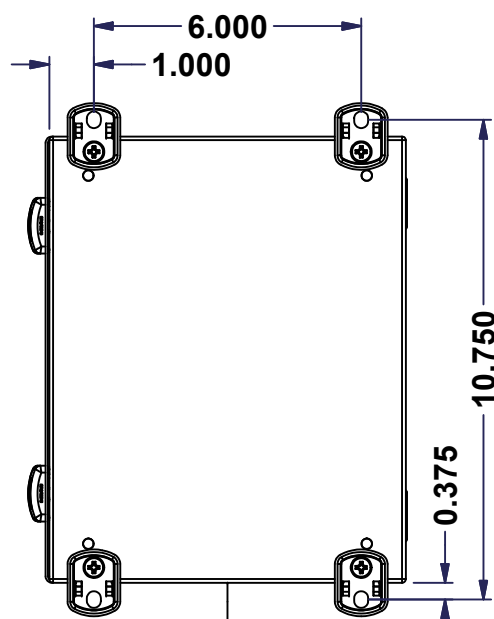

BACK

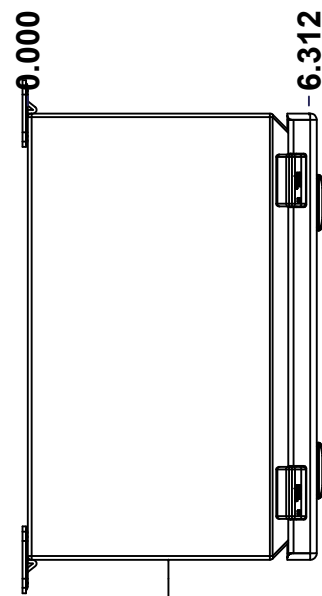

LEFT

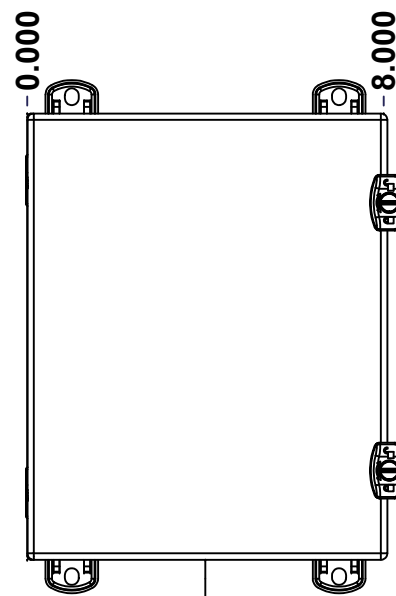

FRONT

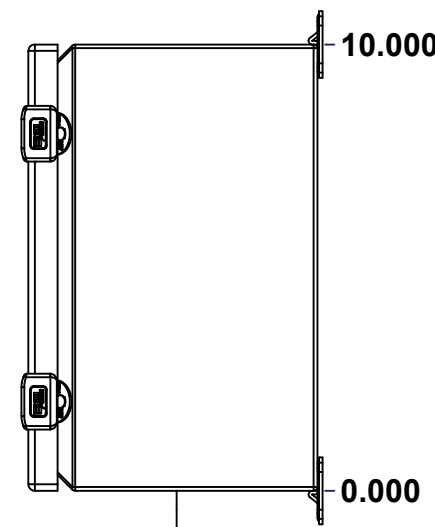

RIGHT

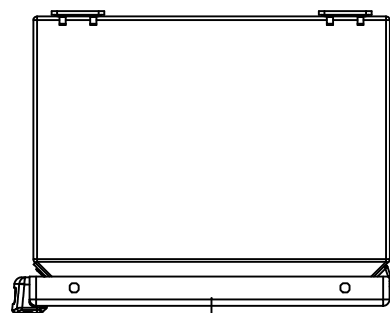

BOTTOM

No.	Revisions	Date	By/Par

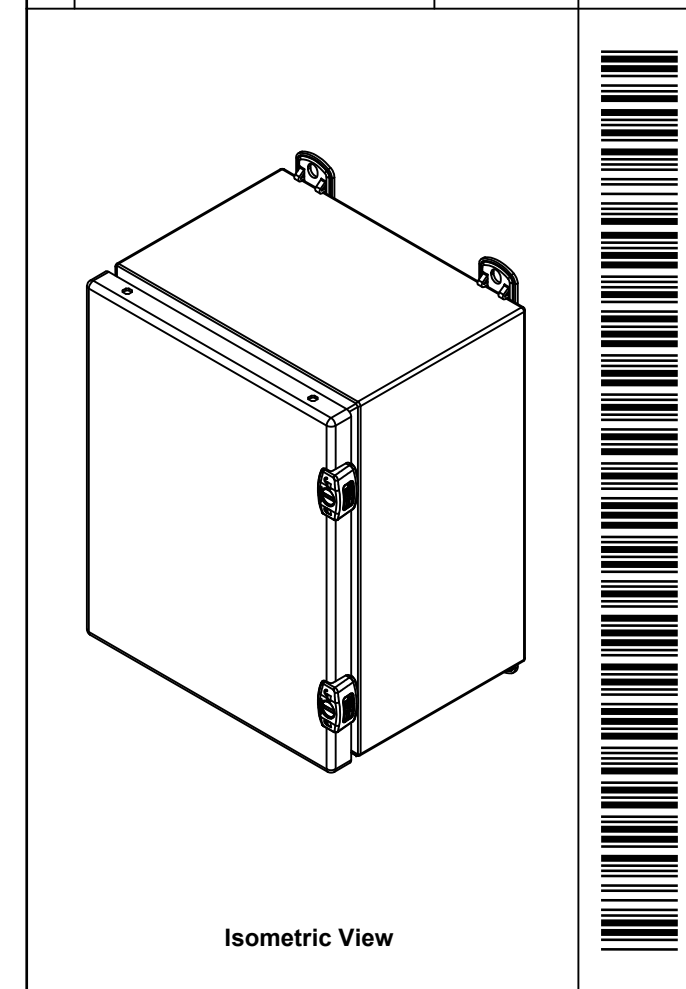

Isometric View

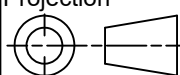

 Tél: (450) 979-4373 Fax: (450) 979-4626 www.exmweb.com		Flatness Aplatissement Max 3.0mm Projection 
Customer Client	Date	Date
Drawn By Dessiné Par	BoxCad: BoxCad	Date 8/18/2014
Material Matière	Aluminum 5052-H32 (1.4mm)	
Color Couleur	Asa-61 Grey	Finish Fini Smooth
Description	Detail Rev.	
5412EALCH 10" x 8" x 6" Assembly		
Part Number Numéro Pièce	Rev.	1 2
5412EALCH100806	0	

SEE BILL OF MATERIAL ON LAST PAGE

This drawing is confidential and must not be reproduced or used without the consent of EXM

Ce dessin est confidentiel et ne doit pas être reproduit ou utilisé sans le consentement de EXM

NOTE	
ITEM	DESCRIPTION
1	NEMA 4X Enclosure
2	C/W Standard ground standoffs on box and cover
3	W/O Standard door stiffener
4	C/W Standard inner panel (Included)
5	C/W Standard inner panel mounting standoffs
6	C/W 885 ESCHMF2 Mounting Feet (Installed)

No.	Revisions	Date	By/Par

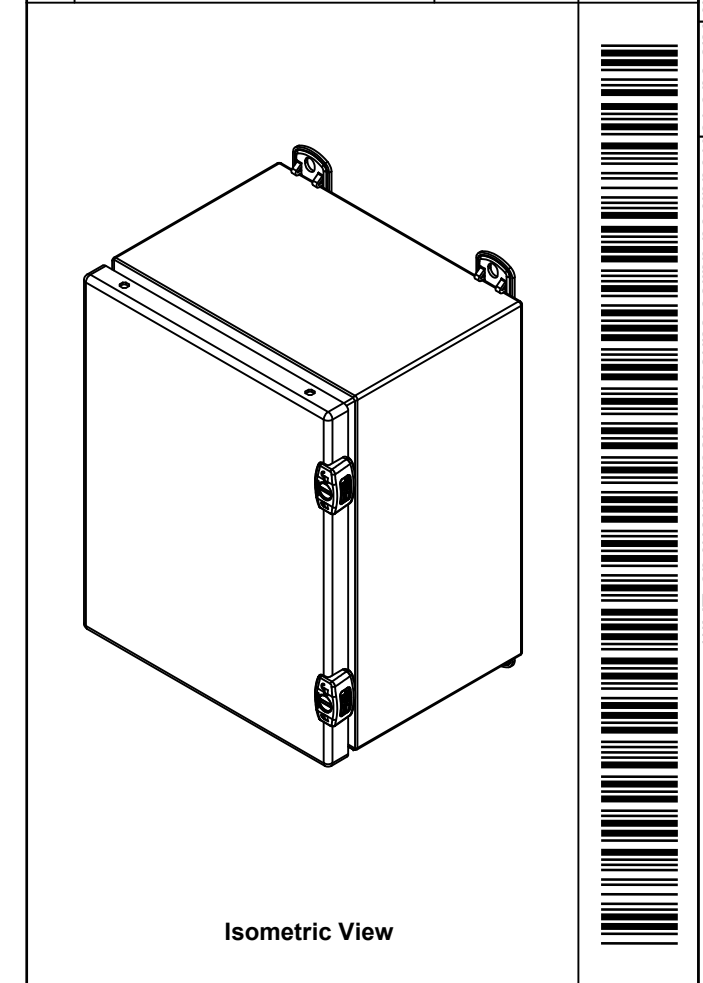

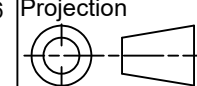
 Tél: (450) 979-4373 Fax: (450) 979-4626 www.exmweb.com	Flatness Aplatissement Max 3.0mm
	Projection 
Customer Client	Date
Drawn By Dessiné Par BoxCad: BoxCad	Date 8/18/2014
Material Matière Aluminum 5052-H32 (1.4mm)	
Color Couleur Asa-61 Grey	Finish Fini Smooth
Description 5412EALCH 10" x 8" x 6" Assembly	Detail Rev.
Part Number Numéro Pièce 5412EALCH100806	Rev. 0

Qty	Part Number	Rev	Description
1	5412EALCH100806C	0	5412EALCH 10" x 8" Cover
1	885 ESSCHMFQ	0	5412 ESSCH Mounting Feet Accessory Kit
1	STK-K-02910	3	5412 ESCH Accessory Kit
8	STK-Q-07200	0	Flange Lock Nut
1	880 SP1008G	0	880 SP1008G - Inner Panel
1	5412EALCH100806B	0	5412EALCH 10" x 8" x 6" Body
2	STK-Q-08100	1	M5 Nylon Insert Lock Nut
Parts List			

PACKING		
ITEM	QTY	DESCRIPTION
STK-E-04311	1	CARTON 5412 ESCH100806
Plastic bag	1	To protect cover surface and inside gasket
Packaging label	1	White label with product number
STK-S-01100	1	ESCH EXM SQUARE STICKER

This drawing is confidential and must not be reproduced or used without the consent of EXM

Ce dessin est confidentiel et ne doit pas être reproduit ou utilisé sans le consentement de EXM

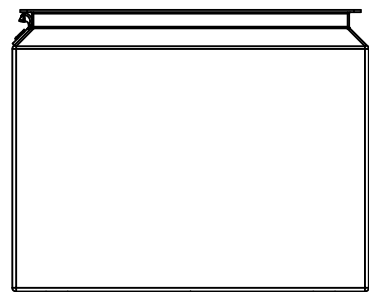

TOP

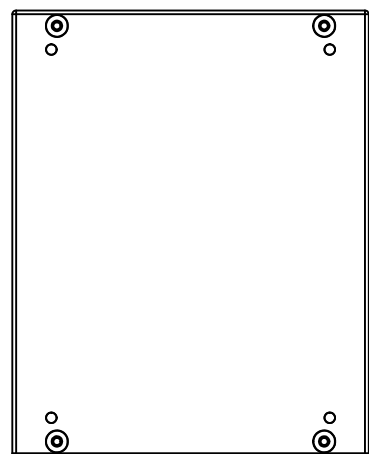

BACK

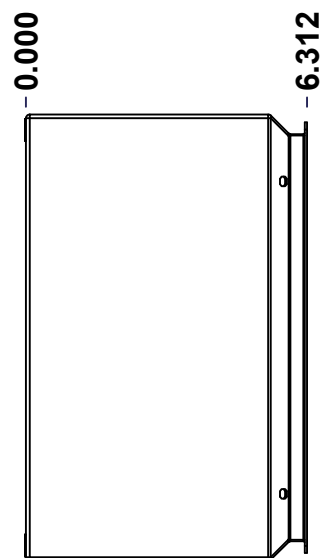

LEFT

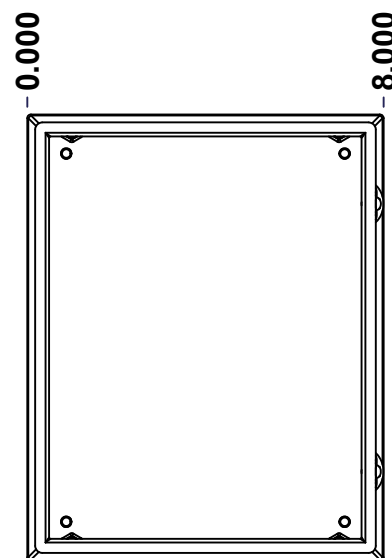

FRONT

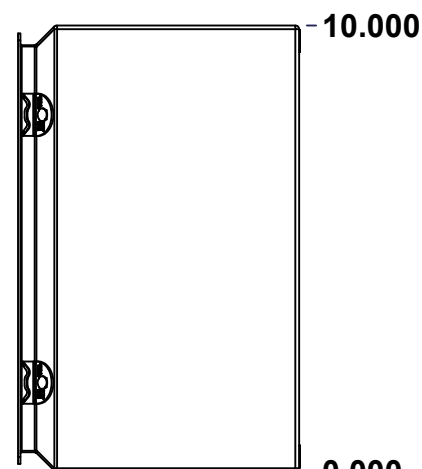

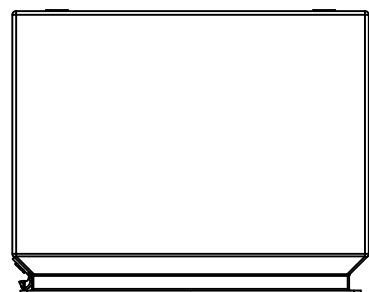

RIGHT

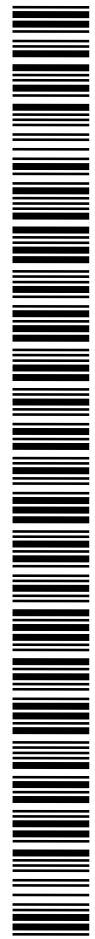
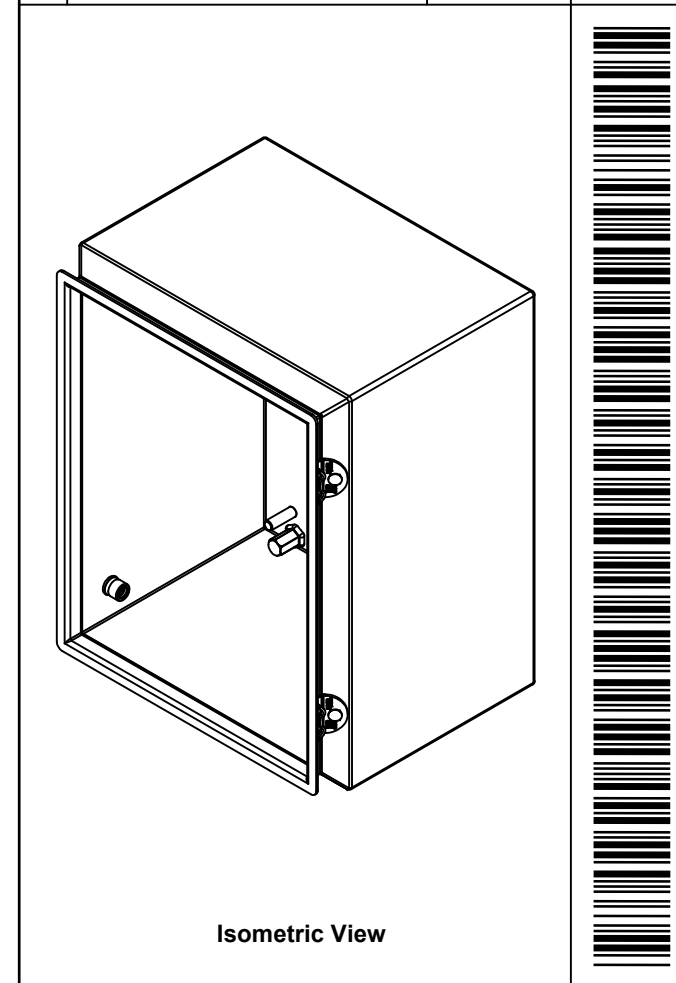

BOTTOM

No.	Revisions	Date	By/Par

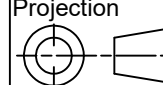

 Tél: (450) 979-4373 Fax: (450) 979-4626 www.exmweb.com		Flatness Aplatissement Max 3.0mm Projection 
Customer Client	Date	
Drawn By Dessiné Par	BoxCad: BoxCad	Date 8/18/2014
Material Matière	Aluminum 5052-H32 (1.4mm)	
Color Couleur	Asa-61 Grey	Finish Fini Smooth
Description	Detail Rev.	
5412EALCH 10" x 8" x 6" Body		
Part Number Numéro Pièce	Rev. 0	1 / 7
5412EALCH100806B		

SEE BILL OF MATERIAL ON LAST PAGE

This drawing is confidential and must not be reproduced or used without the consent of EXM

Ce dessin est confidentiel et ne doit pas être reproduit ou utilisé sans le consentement de EXM

STANDARD FEATURES ARE NOT LISTED IN THIS HOLE TABLE

HOLE TABLE - LEFT VIEW (CUSTOM FEATURE ONLY)

CUT-OUT	XDIM	YDIM	DESCRIPTION
1	4.625	0.875	STANDOFF M6 x 10mm (Inside)

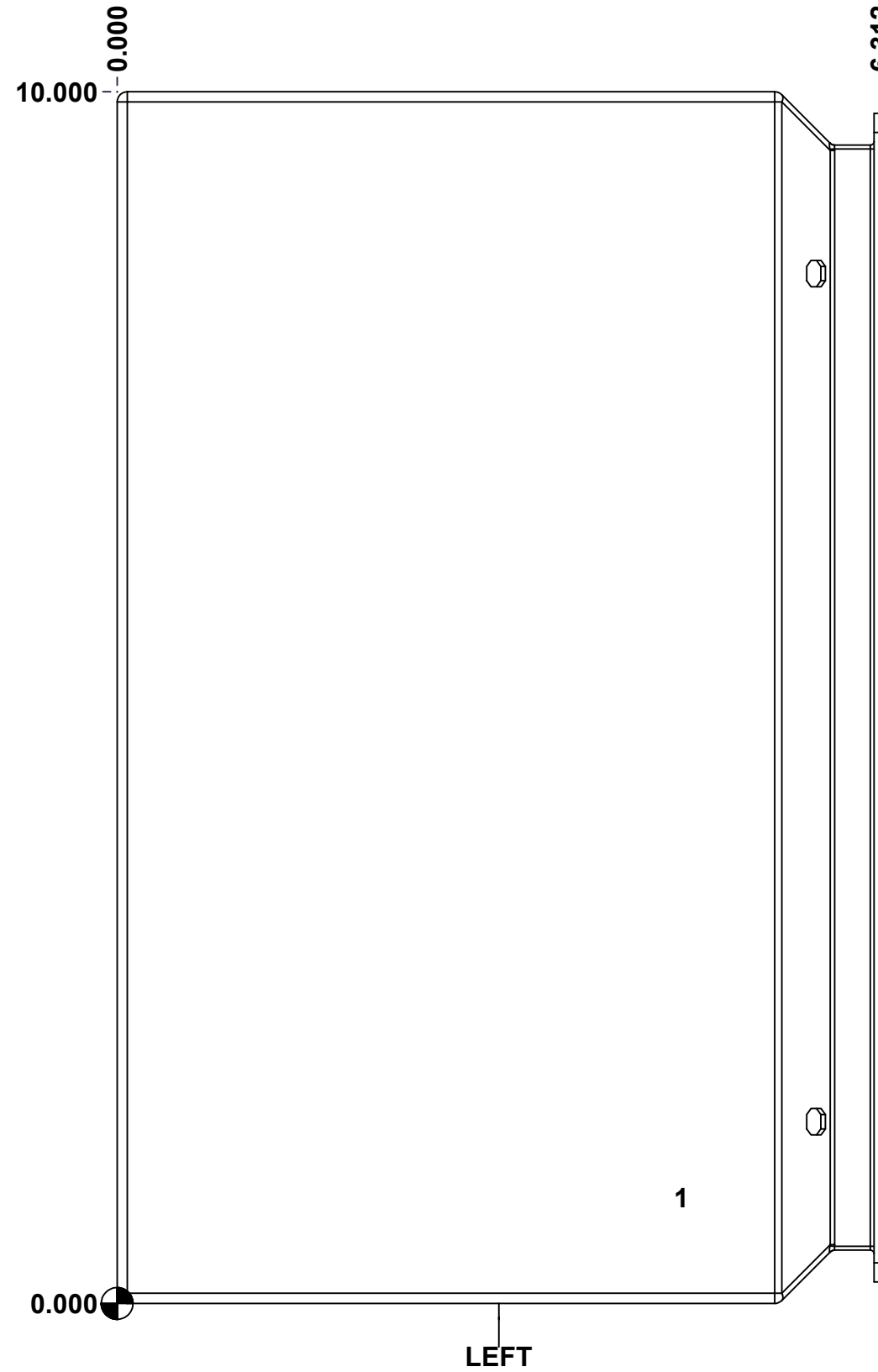

	Description		Status	
	5412EALCH 10" x 8" x 6" Body		(NULL)	
Part Number Numéro Pièce		Rev.	5	7
5412EALCH100806B		0		

This drawing is confidential and must not be reproduced or used without the consent of EXM

Ce dessin est confidentiel et ne doit pas être reproduit ou utilisé sans le consentement de EXM

STANDARD FEATURES ARE NOT LISTED IN THIS HOLE TABLE

HOLE TABLE - BACK VIEW (CUSTOM FEATURE ONLY)

CUT-OUT	XDIM	YDIM	DESCRIPTION
1	7.000	0.000	FOOT 885 ESCHMF2
2	1.000	0.000	FOOT 885 ESCHMF2
3	7.000	10.000	FOOT 885 ESCHMF2
4	1.000	10.000	FOOT 885 ESCHMF2
5	7.000	0.344	RIVET NUT M6_FH_CE (Inside)
6	1.000	0.344	RIVET NUT M6_FH_CE (Inside)
7	7.000	9.656	RIVET NUT M6_FH_CE (Inside)
8	1.000	9.656	RIVET NUT M6_FH_CE (Inside)
9	0.875	9.125	PEM FHS-M6-20 (Inside)
10	7.125	9.125	PEM FHS-M6-20 (Inside)
11	7.125	0.875	PEM FHS-M6-20 (Inside)
12	0.875	0.875	PEM FHS-M6-20 (Inside)

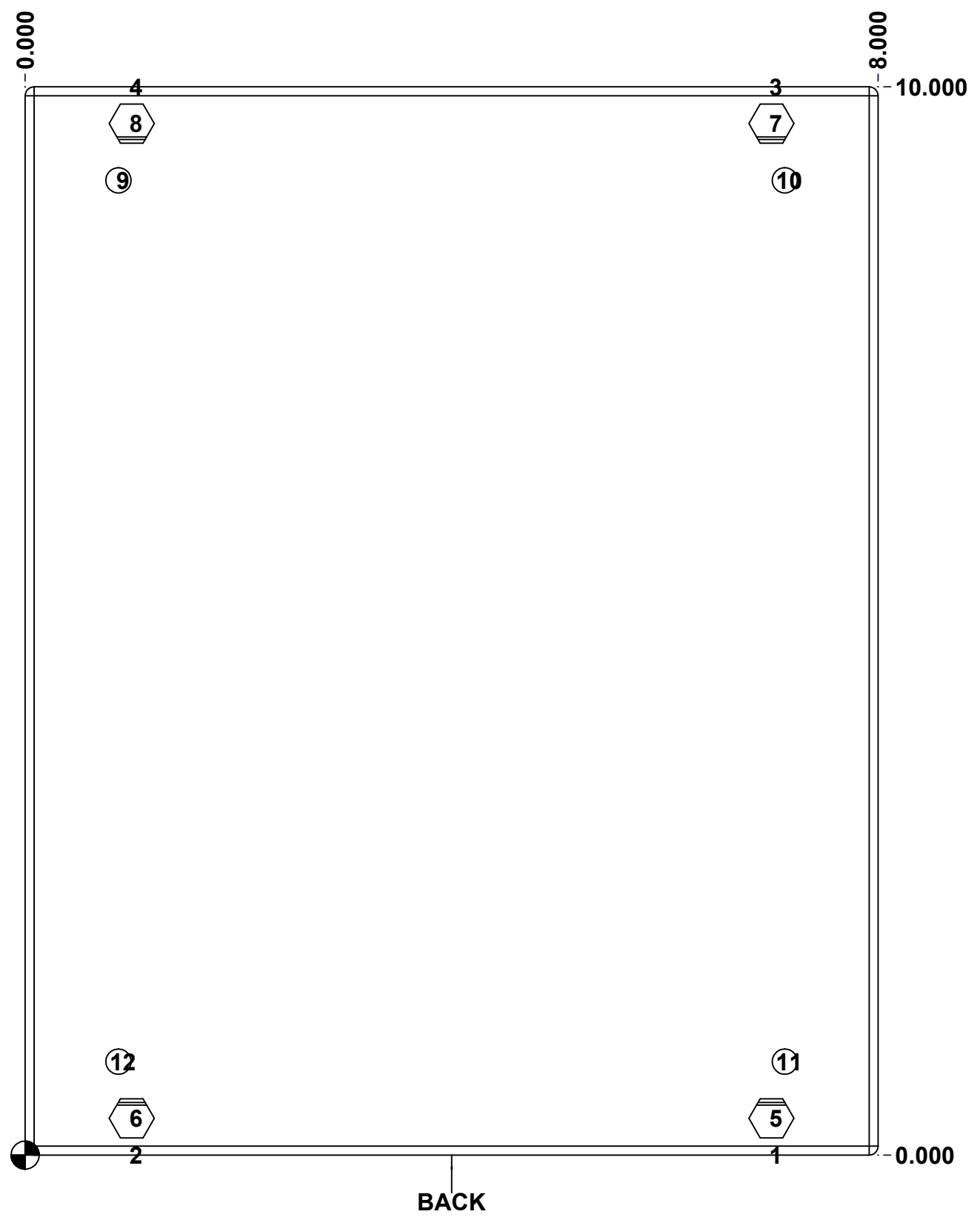

	Description	Status
	5412EALCH 10" x 8" x 6" Body	(NULL)
	Part Number Numéro Pièce	Rev.
	5412EALCH100806B	0
		6
		7

This drawing is confidential and must not be reproduced or used without the consent of EXM

Ce dessin est confidentiel et ne doit pas être reproduit ou utilisé sans le consentement de EXM

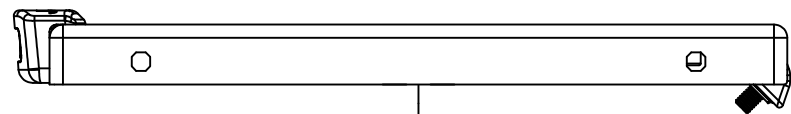

TOP

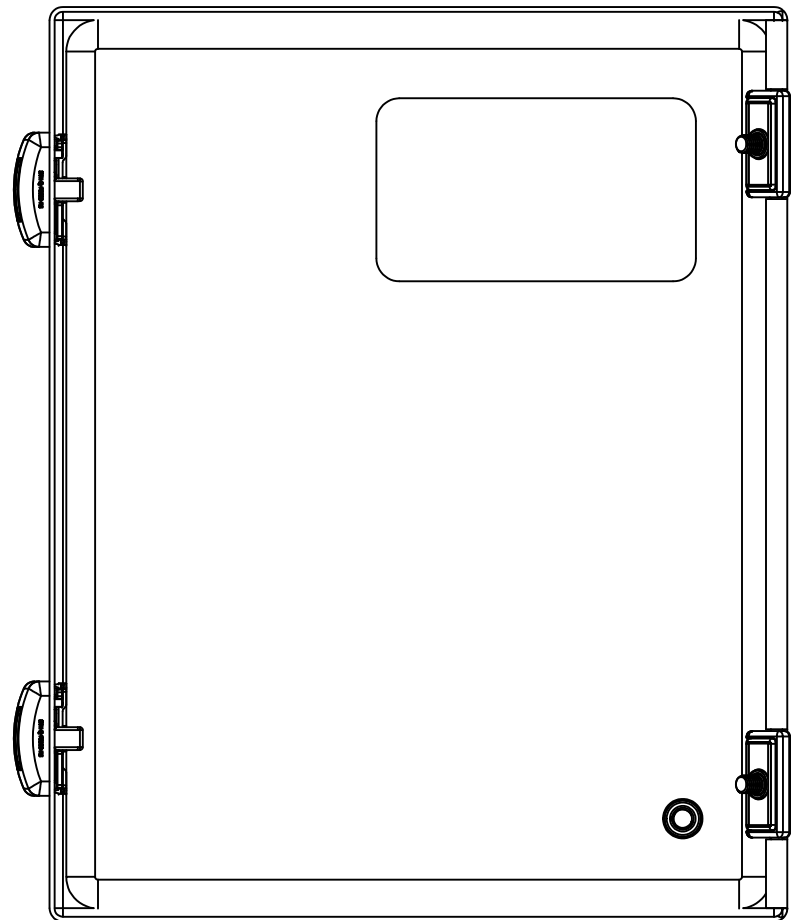

BACK

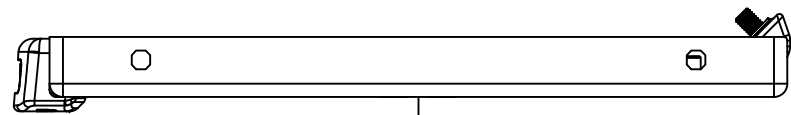

BOTTOM

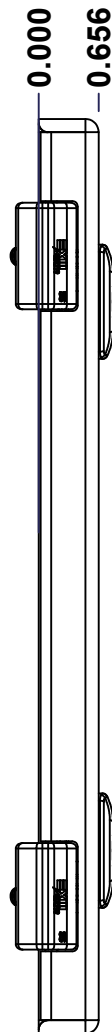

LEFT

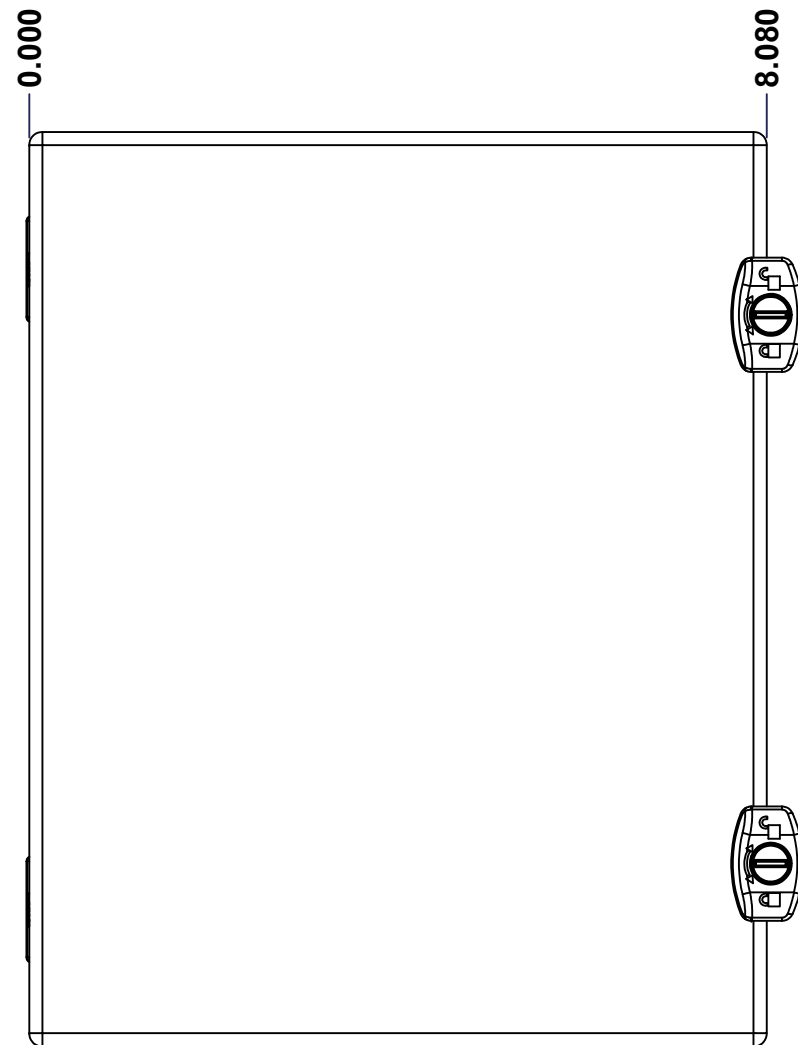

FRONT

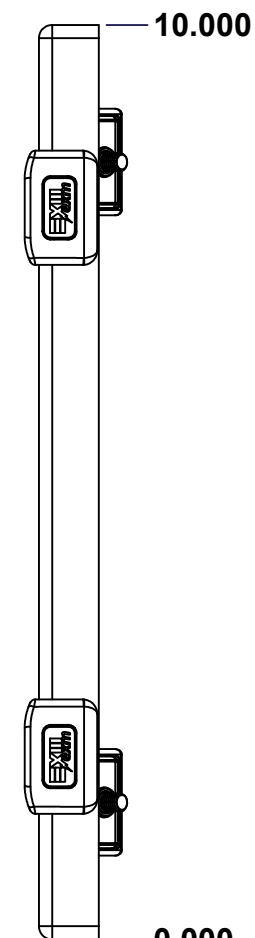

RIGHT

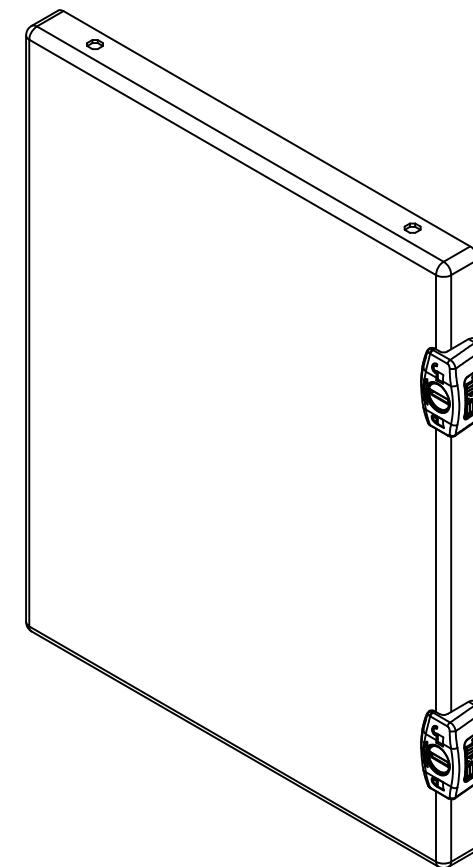

Isometric View

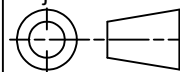

No.	Revisions	Date	By/Par

 Tél: (450) 979-4373 Fax: (450) 979-4626 www.exmweb.com		Flatness Aplatissement Max 3.0mm Projection 
Customer Client		Date
Drawn By Dessiné Par	BoxCad: BoxCad	Date 8/18/2014
Material Matière	Aluminum 5052-H32 (1.4mm)	
Color Couleur	Asa-61 Grey	Finish Fini Smooth
Description		Detail Rev.
5412EALCH 10" x 8" Cover		
Part Number Numéro Pièce	Rev. 0	1 3
5412EALCH100806C		

SEE BILL OF MATERIAL ON LAST PAGE

This drawing is confidential and must not be reproduced or used without the consent of EXM

Ce dessin est confidentiel et ne doit pas être reproduit ou utilisé sans le consentement de EXM

STANDARD FEATURES ARE NOT LISTED IN THIS HOLE TABLE

HOLE TABLE - FRONT VIEW (CUSTOM FEATURE ONLY)

CUT-OUT	XDIM	YDIM	DESCRIPTION
1	2.750	8.000	LABEL_EXM
2	8.080	8.000	LOCK 880 SCQ2MS @ 0.0°
3	8.080	2.000	LOCK 880 SCQ2MS @ 0.0°
4	1.145	1.125	STANDOFF M6 x 10mm (Inside)

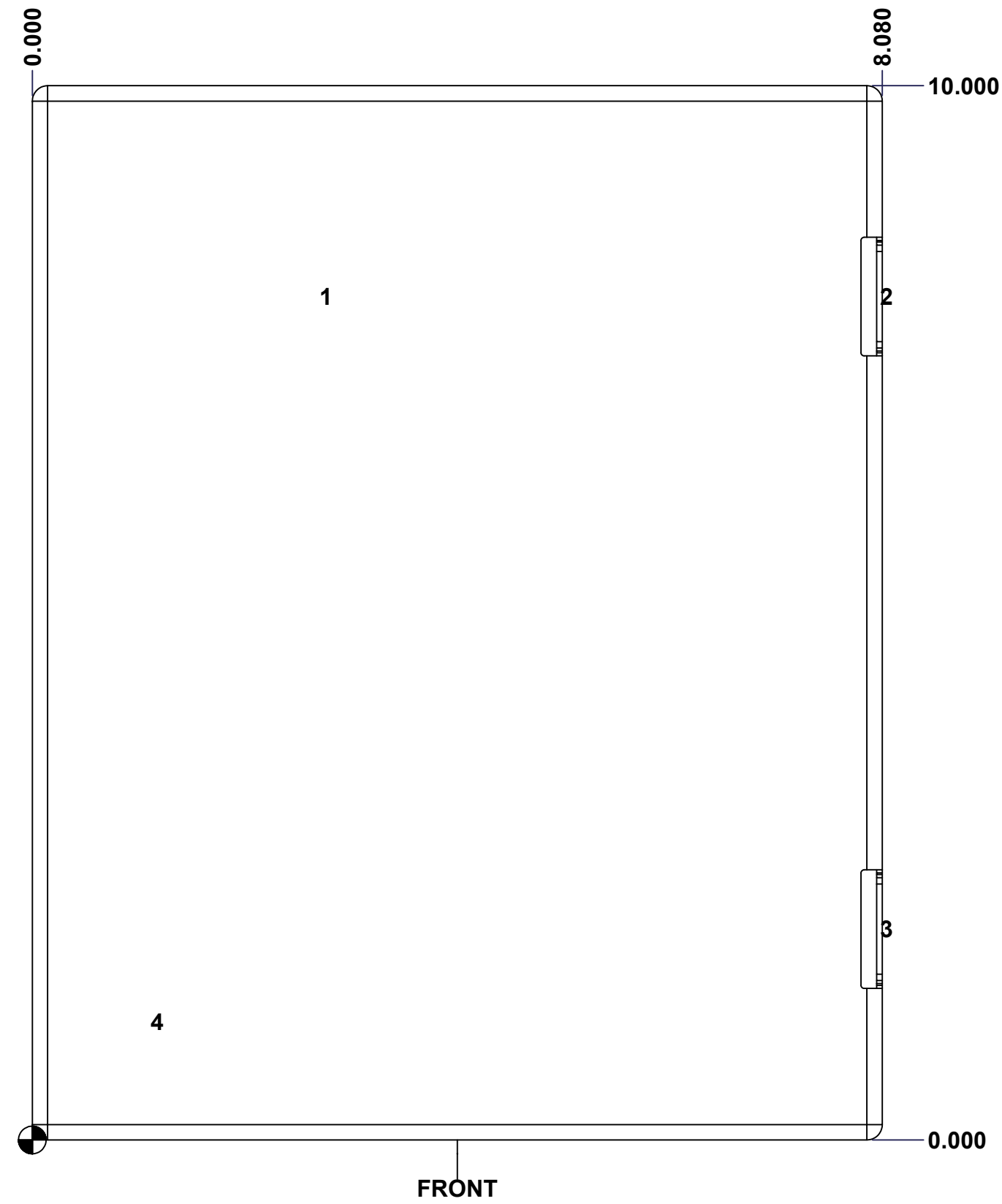



	Description	Status	
	5412EALCH 10" x 8" Cover	(NULL)	
	Part Number Numéro Pièce	Rev.	
	5412EALCH100806C	0	2 3

This drawing is confidential and must not be reproduced or used without the consent of EXM

Ce dessin est confidentiel et ne doit pas être reproduit ou utilisé sans le consentement de EXM

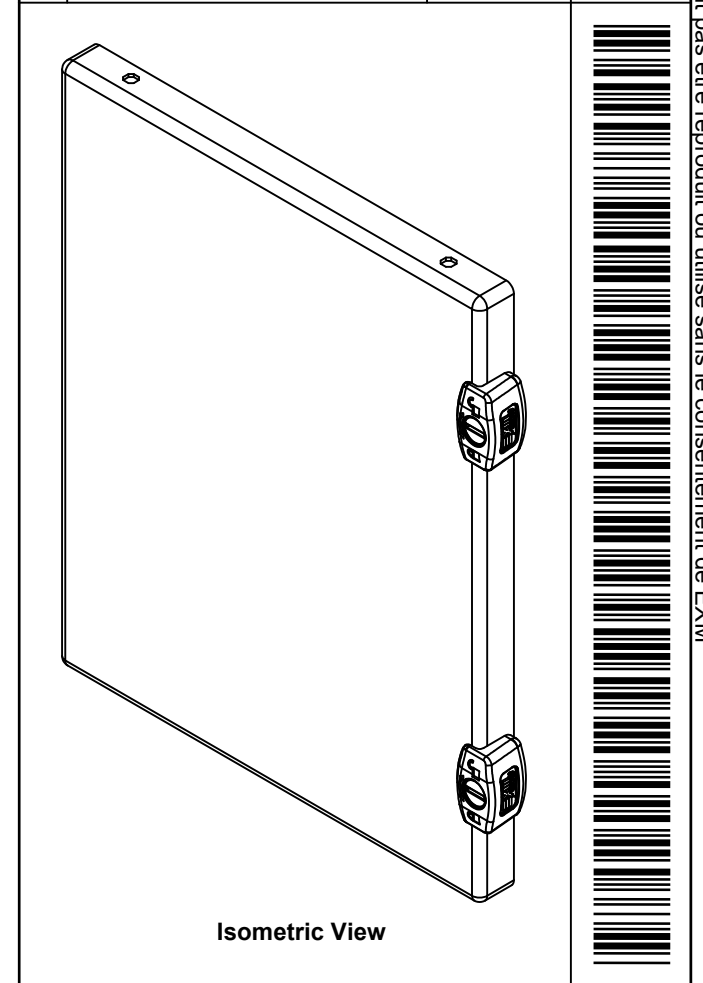
No.	Revisions	Date	By/Par

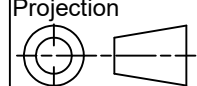

 Tél: (450) 979-4373 Fax: (450) 979-4626 www.exmweb.com		Flatness Aplatissement Max 3.0mm Projection 
Customer Client	Date	
Drawn By Dessiné Par	BoxCad: BoxCad	Date 8/18/2014
Material Matière	Aluminum 5052-H32 (1.4mm)	
Color Couleur	Asa-61 Grey	Finish Fini Smooth
Description		Detail Rev.
5412EALCH 10" x 8" Cover		
Part Number Numéro Pièce	Rev. 3	3
5412EALCH100806C	0	3

Qty	Part Number	Rev	Description
1	STK-Q-08400	4	Aluminum Standoff M6 x 10mm
1	5412EALCH100806G	0	5412EALCH 10" x 8" Gasket
1	STK-S-00100	0	3.5" x 2" Silver Milar Flexcon Sticker
1	STK-P-02400S	0	Powder Paint (Asa-61 Grey / Smooth)
1	5412EALCH100806C-P	0	5412EALCH 10" x 8" Cover Part
2	STK-A-33038	3	5412 ESSMCH - Stainless Steel Hinge
2	880SCQ2S	3	5412 ESMCH - External Lock Assy - Slot Lock
Parts List			

This drawing is confidential and must not be reproduced or used without the consent of EXM

Ce dessin est confidentiel et ne doit pas être reproduit ou utilisé sans le consentement de EXM

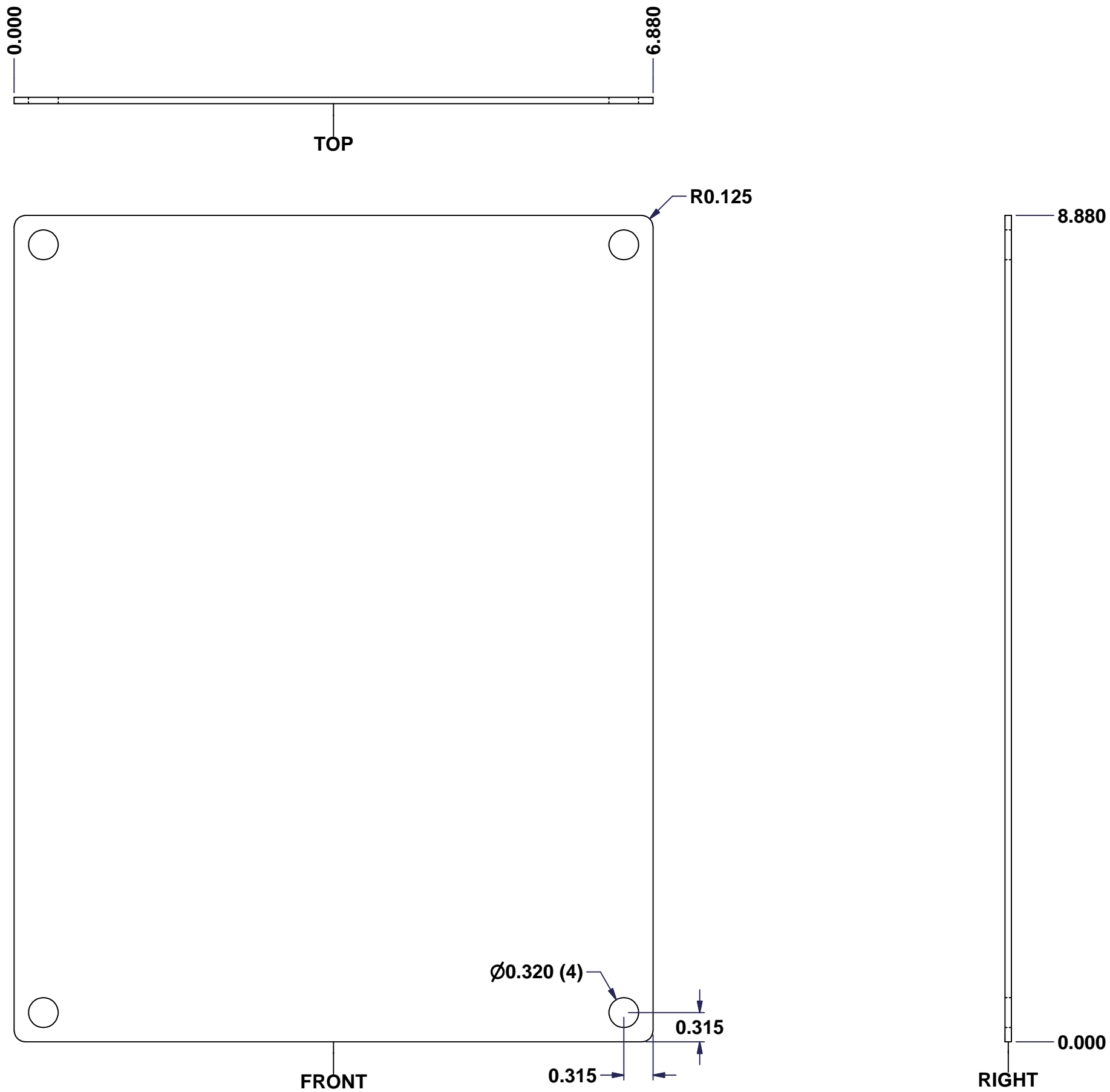

No.	Revisions	Date	By/Par

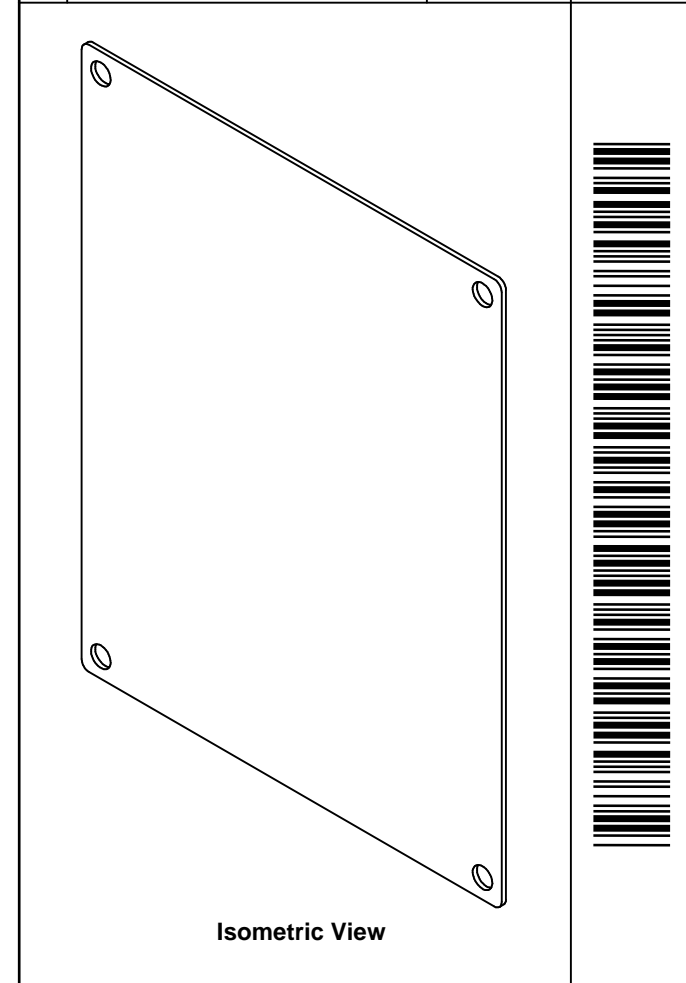

Tél: (450) 979-4373 Fax: (450) 979-4626 www.exmweb.com		Flatness Aplatissement Max 3.0mm Projection
Customer Client	Date	
Drawn By / Dessiné Par: BoxCad	Date: 23-Jan-07	
Material / Matière: 14 Ga Galvanized (1.7mm)		
Color / Couleur: Unpainted	Finish / Fini: Galvanized	
Description: 880 SP1008G - Inner Panel		Detail Rev.
Part Number / Numéro Pièce: 880 SP1008G	Rev. 0	1 / 2

SEE BILL OF MATERIAL ON LAST PAGE

This drawing is confidential and must not be reproduced or used without the consent of EXM

Ce dessin est confidentiel et ne doit pas être reproduit ou utilisé sans le consentement de EXM

No.	Revisions	Date	By/Par

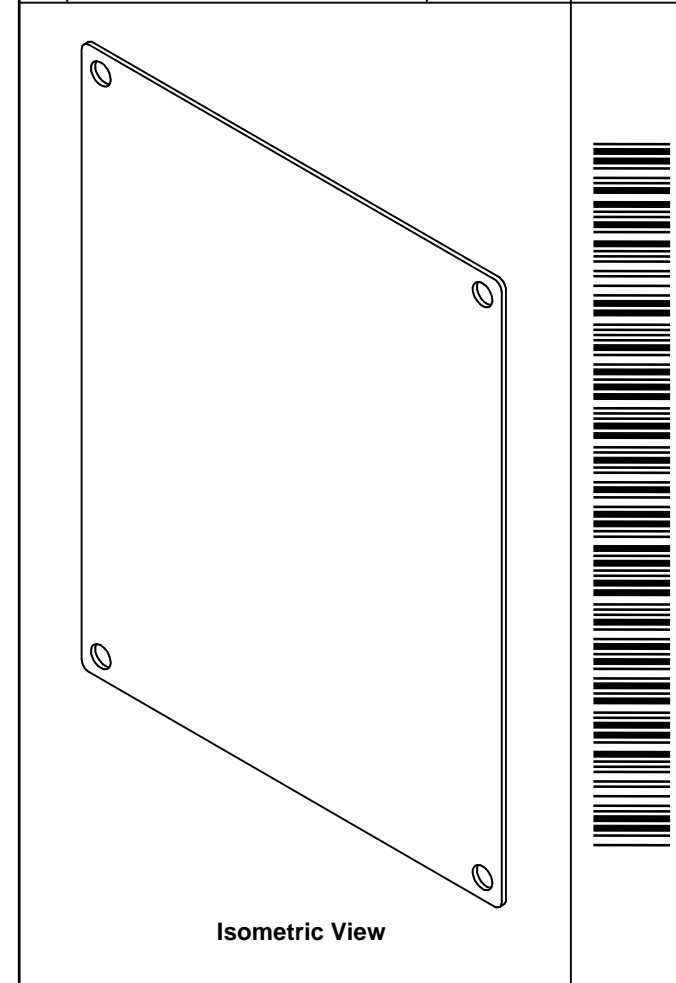

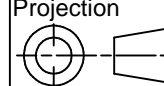
 Tél: (450) 979-4373 Fax: (450) 979-4626 www.exmweb.com		Flatness Aplatissement Max 3.0mm
Customer Client		Projection 
Drawn By Dessiné Par BoxCad		Date 23-Jan-07
Material Matière 14 Ga Galvanized (1.7mm)		
Color Couleur Unpainted	Finish Fini Galvanized	
Description 880 SP1008G - Inner Panel		Detail Rev.
Part Number Numéro Pièce 880 SP1008G		Rev. 0

Qty	Part Number	Rev	Description
1	880 SP1008G-P	0	880 SP1008G - Inner Panel Part
Parts List			

2
2