

This drawing is confidential and must not be reproduced or used without the consent of EXM

Ce dessin est confidentiel et ne doit pas être reproduit ou utilisé sans le consentement de EXM

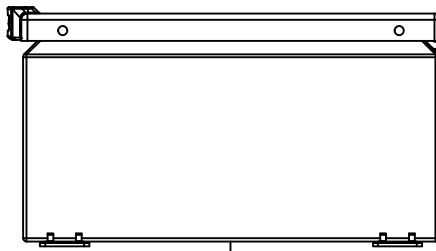

TOP

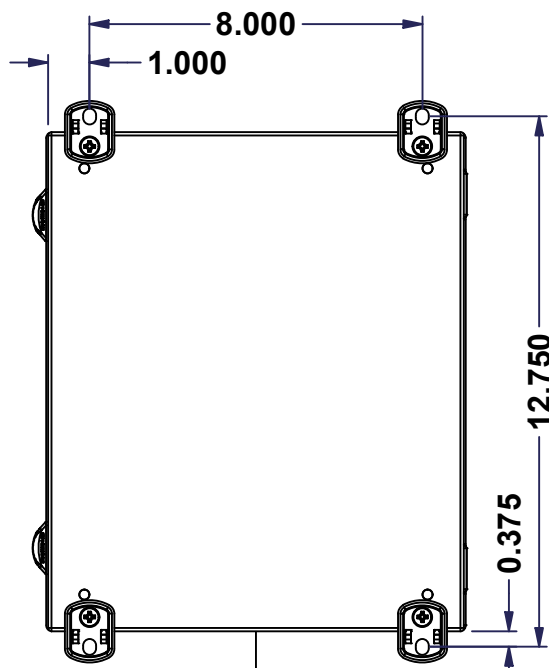

BACK

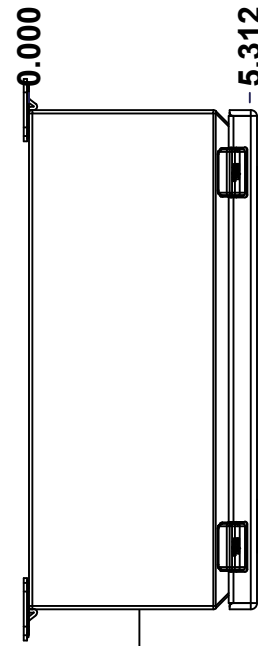

LEFT

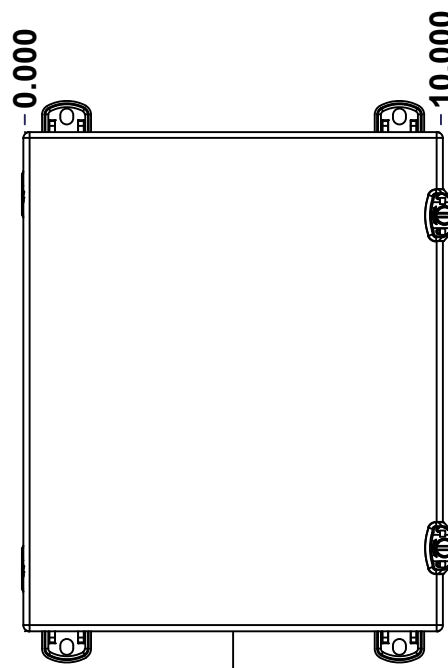

FRONT

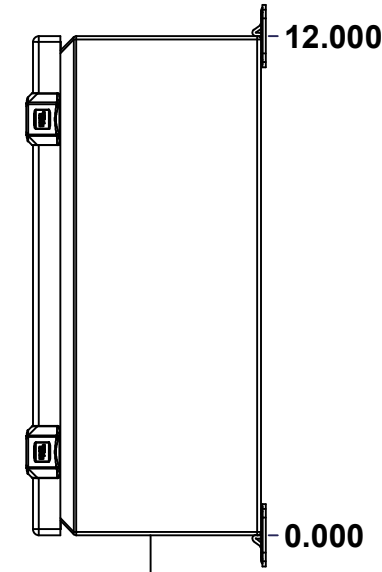

RIGHT

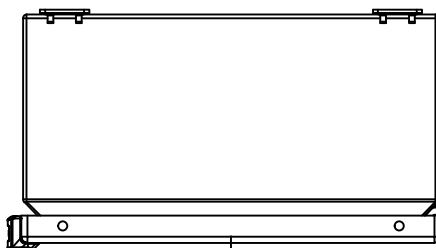

BOTTOM

No.	Revisions	Date	By/Par

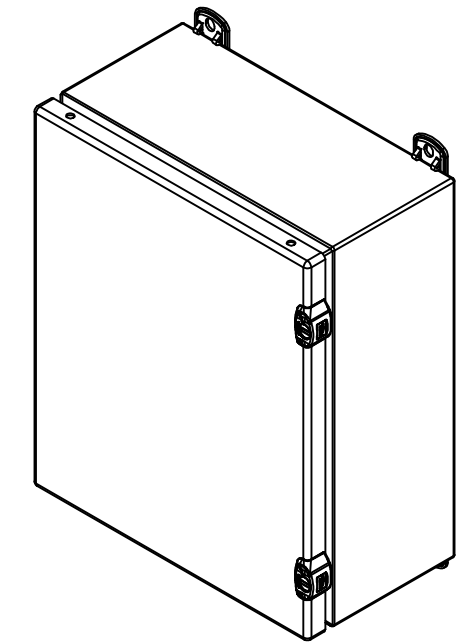

Isometric View



Tél: (450) 979-4373
 Fax: (450) 979-4626
www.exmweb.com

Flatness
Aplatissement
Max 3.0mm
Projection

Customer Client	Date
Drawn By Dessiné Par BoxCad: BoxCad	Date 19-Aug-14
Material Matière Aluminum 5052-H32 (1.4mm)	
Color Couleur Asa-61 Grey	Finish Fini Smooth
Description 5412EALCH 12" x 10" x 5" Assembly	Detail Rev.
Part Number Numéro Pièce 5412EALCH121005	Rev. 1 0 / 9

SEE BILL OF MATERIAL ON LAST PAGE

This drawing is confidential and must not be reproduced or used without the consent of EXM

Ce dessin est confidentiel et ne doit pas être reproduit ou utilisé sans le consentement de EXM

NOTE	
ITEM	DESCRIPTION
1	NEMA 4X Enclosure (IP66)
2	C/W Standard ground standoffs on box and cover
3	W/O Standard door stiffener
4	C/W Standard inner panel (Included)
5	C/W Standard inner panel mounting standoffs
6	C/W 885 ESCHMF2 Mounting Feet (Installed)

No.	Revisions	Date	By/Par

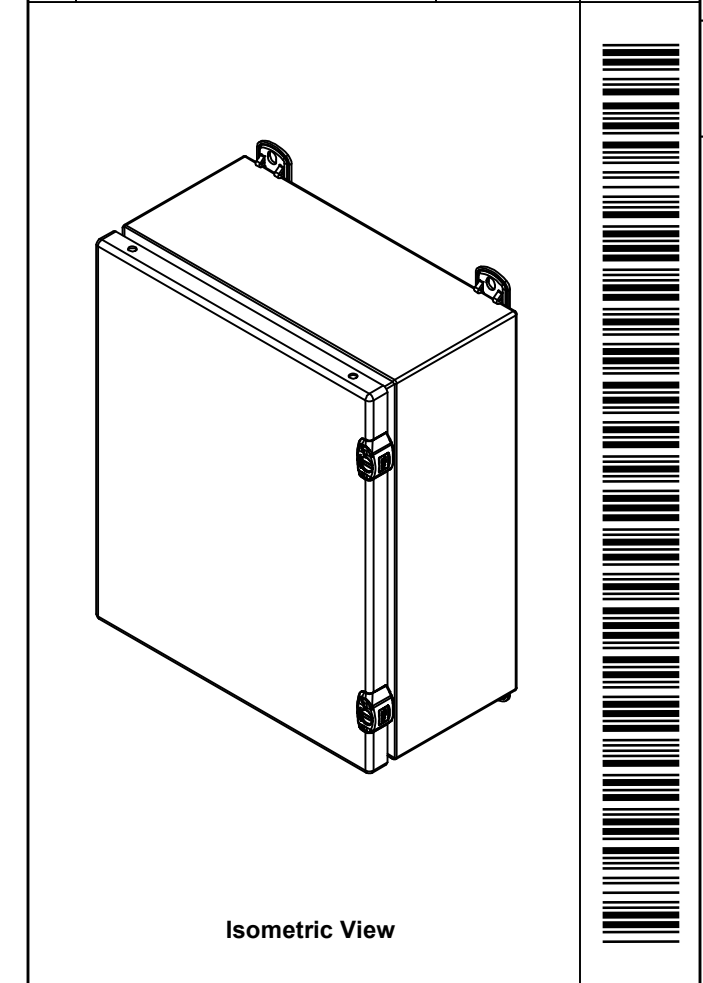

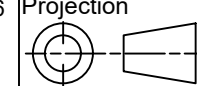
 Tél: (450) 979-4373 Fax: (450) 979-4626 www.exmweb.com	Flatness Aplatissement Max 3.0mm
	Projection 
Customer Client	Date
Drawn By Dessiné Par BoxCad: BoxCad	Date 19-Aug-14
Material Matière	Aluminum 5052-H32 (1.4mm)
Color Couleur	Asa-61 Grey
Finish Fini	Smooth
Description	Detail Rev.
5412EALCH 12" x 10" x 5" Assembly	
Part Number Numéro Pièce	Rev. 2
5412EALCH121005	0

Qty	Part Number	Rev	Description
1	5412EALCH121005C	0	5412EALCH 12" x 10" Cover
1	885 ESSCHMFQ	0	5412 ESSCH Mounting Feet Accessory Kit
1	STK-K-02910	3	5412 ESCH Accessory Kit
8	STK-Q-07210	0	Flange Lock Nut M6
1	880 SP1210G	0	880 SP1210G - Inner Panel
1	5412EALCH121005B	0	5412EALCH 12" x 10" x 5" Body
2	STK-A-08126	0	M5 Stainless Steel 316 Nylon Insert Lock Nut with Incorporated Sealing Washer
Parts List			

PACKING		
ITEM	QTY	DESCRIPTION
STK-E-04316	1	CARTON 5412 ESCH121005
Plastic bag	1	To protect cover surface and inside gasket
Packaging label	1	White label with product number
STK-S-01100	1	ESCH EXM SQUARE STICKER

This drawing is confidential and must not be reproduced or used without the consent of EXM

Ce dessin est confidentiel et ne doit pas être reproduit ou utilisé sans le consentement de EXM

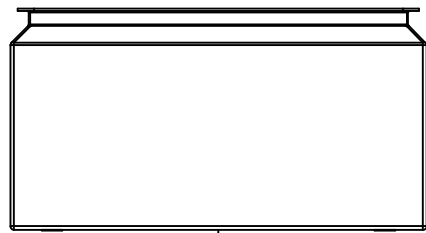

TOP

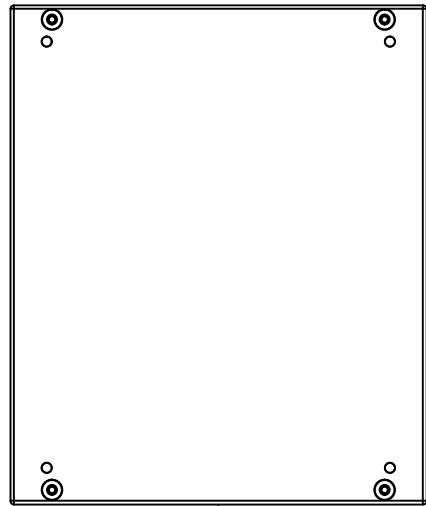

BACK

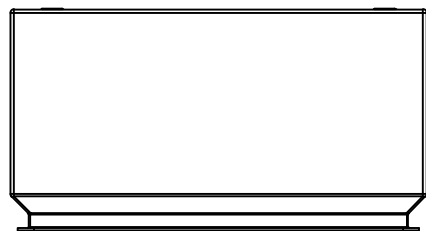

BOTTOM

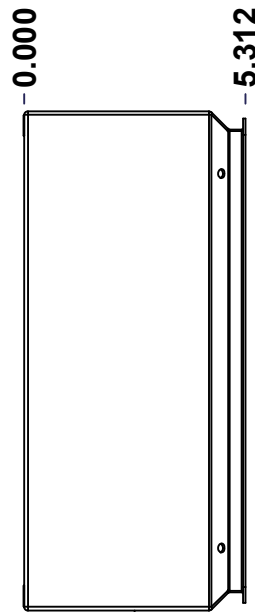

LEFT

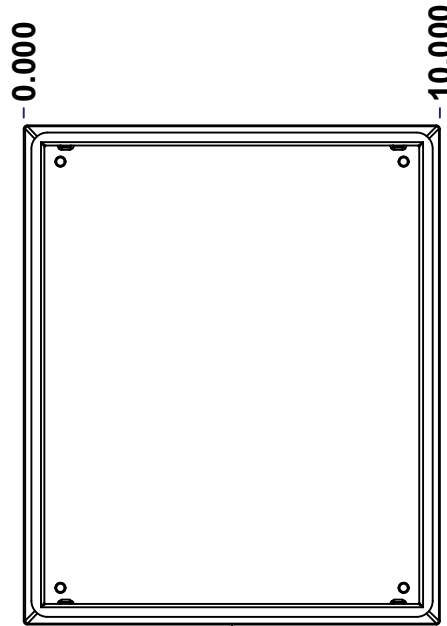

FRONT

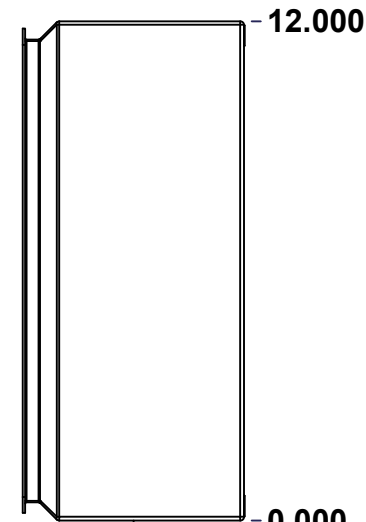

RIGHT

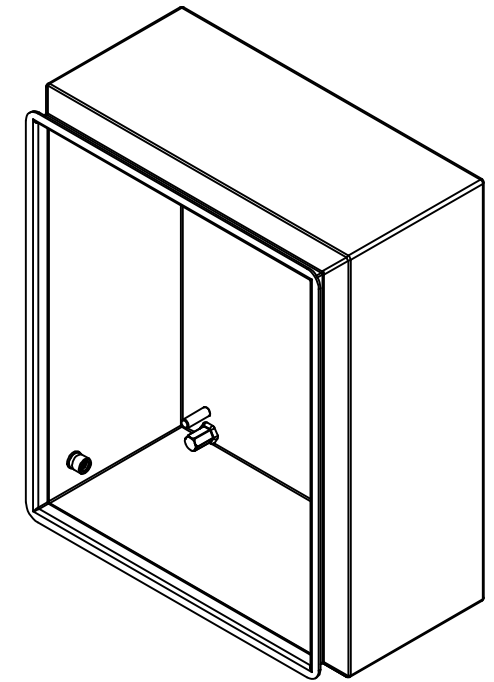

Isometric View

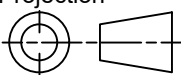

No.	Revisions	Date	By/Par

 Tél: (450) 979-4373 Fax: (450) 979-4626 www.exmweb.com		Flatness Aplatissement Max 3.0mm Projection 
Customer Client	Date	
Drawn By Dessiné Par	BoxCad: BoxCad	Date 19-Aug-14
Material Matière	Aluminum 5052-H32 (1.4mm)	
Color Couleur	Asa-61 Grey	Finish Fini Smooth
Description	Detail Rev.	
5412EALCH 12" x 10" x 5" Body		
Part Number Numéro Pièce	Rev.	3
5412EALCH121005B	0	9

SEE BILL OF MATERIAL ON LAST PAGE

This drawing is confidential and must not be reproduced or used without the consent of EXM

Ce dessin est confidentiel et ne doit pas être reproduit ou utilisé sans le consentement de EXM

STANDARD FEATURES ARE NOT LISTED IN THIS HOLE TABLE			
HOLE TABLE - LEFT VIEW (CUSTOM FEATURE ONLY)			
CUT-OUT	XDIM	YDIM	DESCRIPTION
1	3.625	0.875	STANDOFF M6 x 10mm (Inside)

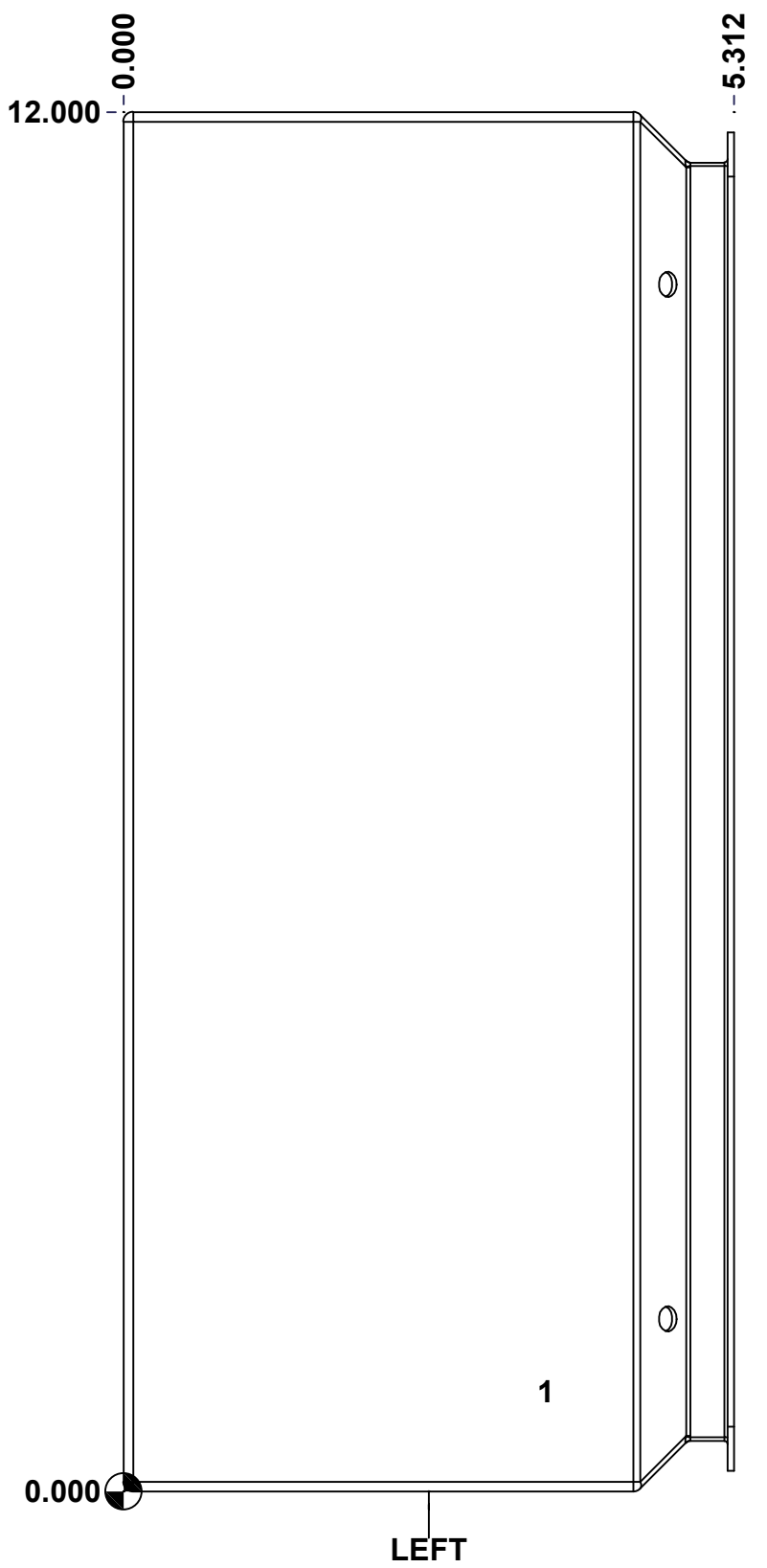

	Description		Status
	5412EALCH 12" x 10" x 5" Body		(NULL)
	Part Number Numéro Pièce		Rev.
	5412EALCH121005B		0 / 4 9

This drawing is confidential and must not be reproduced or used without the consent of EXM

Ce dessin est confidentiel et ne doit pas être reproduit ou utilisé sans le consentement de EXM

STANDARD FEATURES ARE NOT LISTED IN THIS HOLE TABLE

HOLE TABLE - BACK VIEW (CUSTOM FEATURE ONLY)

CUT-OUT	XDIM	YDIM	DESCRIPTION
1	9.000	12.000	FOOT 885 ESCHMF2
2	1.000	12.000	FOOT 885 ESCHMF2
3	9.000	0.000	FOOT 885 ESCHMF2
4	1.000	0.000	FOOT 885 ESCHMF2
5	9.000	11.656	RIVET NUT M6_FH_CE (Inside)
6	1.000	11.656	RIVET NUT M6_FH_CE (Inside)
7	9.000	0.344	RIVET NUT M6_FH_CE (Inside)
8	1.000	0.344	RIVET NUT M6_FH_CE (Inside)
9	0.875	11.125	PEM FHS-M6-20 (Inside)
10	9.125	11.125	PEM FHS-M6-20 (Inside)
11	9.125	0.875	PEM FHS-M6-20 (Inside)
12	0.875	0.875	PEM FHS-M6-20 (Inside)

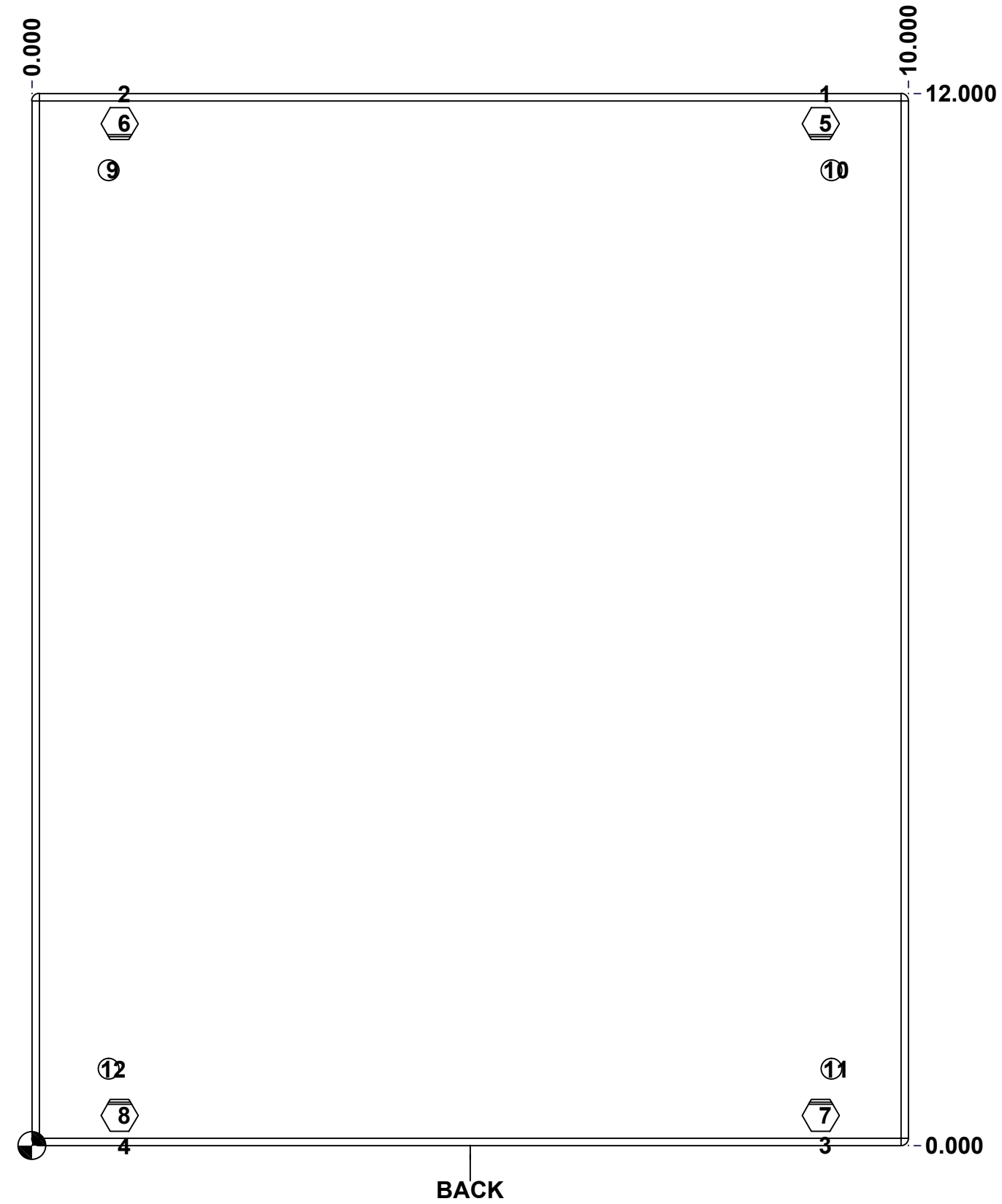

	Description	Status
	5412EALCH 12" x 10" x 5" Body	(NULL)
	Part Number Numéro Pièce	Rev.
	5412EALCH121005B	0 / 5 / 9

This drawing is confidential and must not be reproduced or used without the consent of EXM

Ce dessin est confidentiel et ne doit pas être reproduit ou utilisé sans le consentement de EXM

No.	Revisions	Date	By/Par

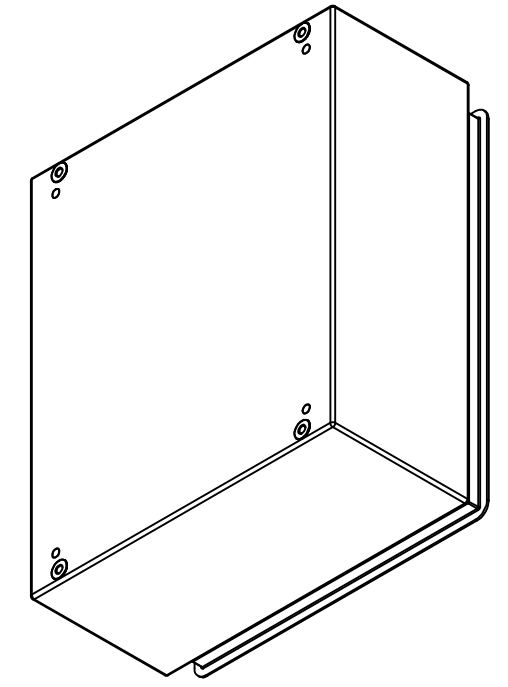

Isometric View

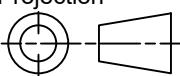

 Tél: (450) 979-4373 Fax: (450) 979-4626 www.exmweb.com	Flatness Aplatissement	Max 3.0mm
	Projection	
Customer Client	Date	
Drawn By Dessiné Par	BoxCad: BoxCad	Date 19-Aug-14
Material Matière	Aluminum 5052-H32 (1.4mm)	
Color Couleur	Asa-61 Grey	Finish Fini Smooth
Description	Detail Rev.	
5412EALCH 12" x 10" x 5" Body		
Part Number Numéro Pièce	Rev.	6
5412EALCH121005B	0	9

Qty	Part Number	Rev	Description
4	STK-PEM-FHS-M6-20	0	SS PEM Self-Clinching Stud M6 x 20.0mm
1	STK-Q-08400	4	Aluminum Standoff M6 x 10mm
1	5412EALCH121005B-P	0	5412EALCH 12" x 10" x 5" Body Part
4	RIVET_NUT_SS_M6_FH_CE	0	Stainless Steel Rivet Nut M6 (Low Profile Close End)
1	STK-P-02400S	0	Powder Paint (Asa-61 Grey / Smooth)
Parts List			

This drawing is confidential and must not be reproduced or used without the consent of EXM

Ce dessin est confidentiel et ne doit pas être reproduit ou utilisé sans le consentement de EXM

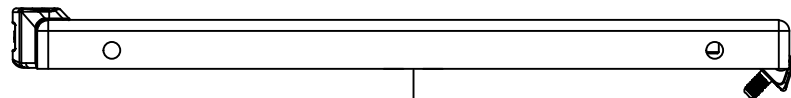

TOP

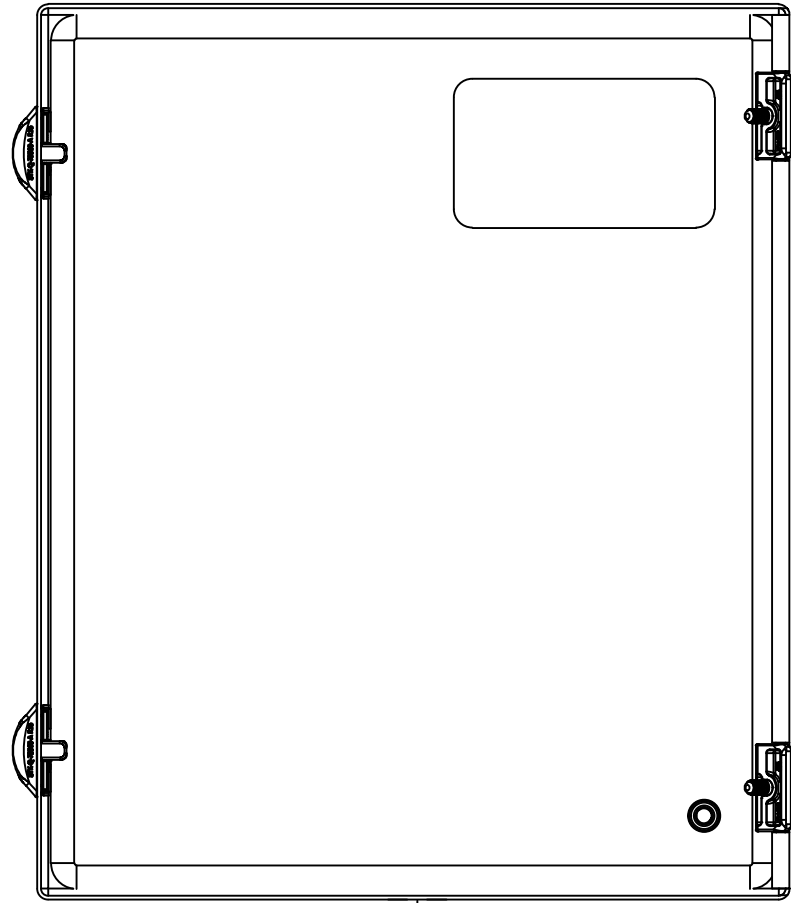

BACK

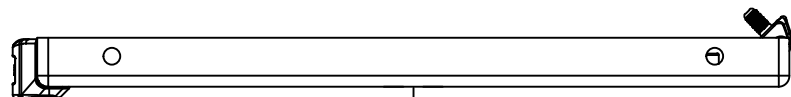

BOTTOM

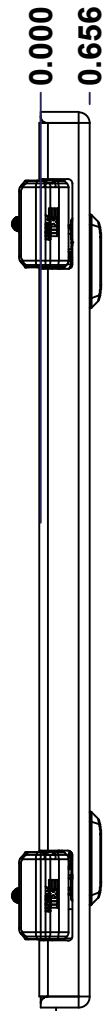

LEFT

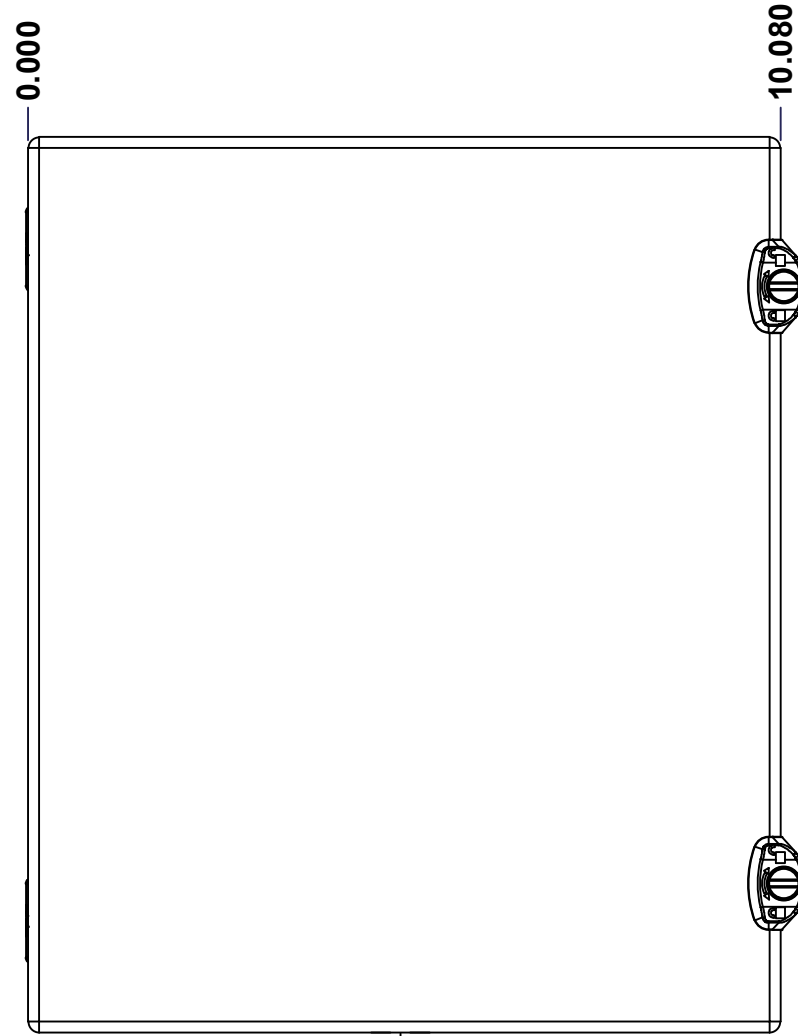

FRONT

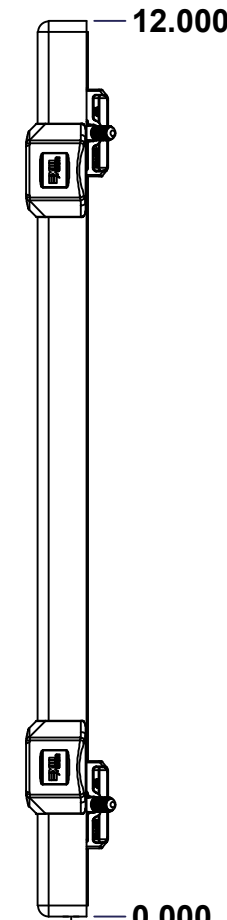

RIGHT

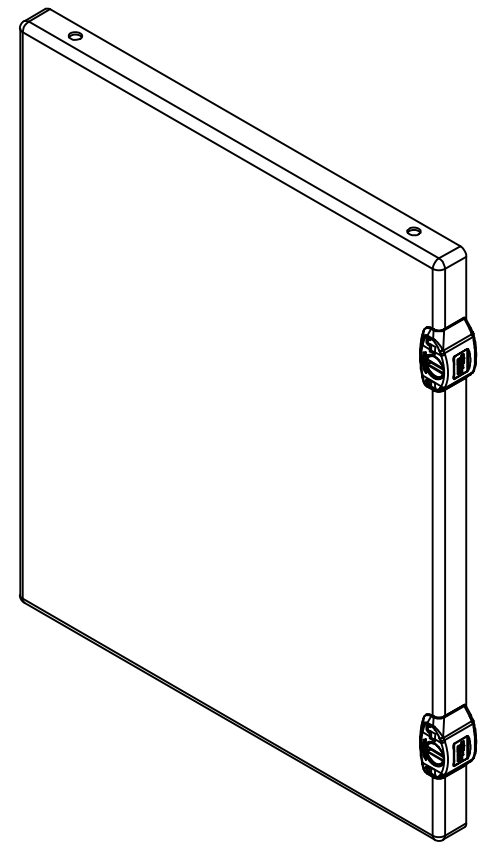

Isometric View

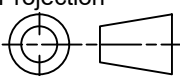

No.	Revisions	Date	By/Par

 Tél: (450) 979-4373 Fax: (450) 979-4626 www.exmweb.com		Flatness Aplatissement Max 3.0mm Projection 
Customer Client	Date	
Drawn By Dessiné Par	BoxCad: BoxCad	Date 19-Aug-14
Material Matière	Aluminum 5052-H32 (1.4mm)	
Color Couleur	Asa-61 Grey	Finish Fini Smooth
Description	Detail Rev.	
5412EALCH 12" x 10" Cover		
Part Number Numéro Pièce	Rev.	7
5412EALCH121005C	0	9

SEE BILL OF MATERIAL ON LAST PAGE

This drawing is confidential and must not be reproduced or used without the consent of EXM

Ce dessin est confidentiel et ne doit pas être reproduit ou utilisé sans le consentement de EXM

STANDARD FEATURES ARE NOT LISTED IN THIS HOLE TABLE			
HOLE TABLE - FRONT VIEW (CUSTOM FEATURE ONLY)			
CUT-OUT	XDIM	YDIM	DESCRIPTION
1	2.750	10.000	LABEL_EXM
2	1.145	1.125	STANDOFF M6 x 10mm (Inside)
3	10.080	2.000	LOCK 880 SCQ2-SL @ 0.0°
4	10.080	10.000	LOCK 880 SCQ2-SL @ 0.0°

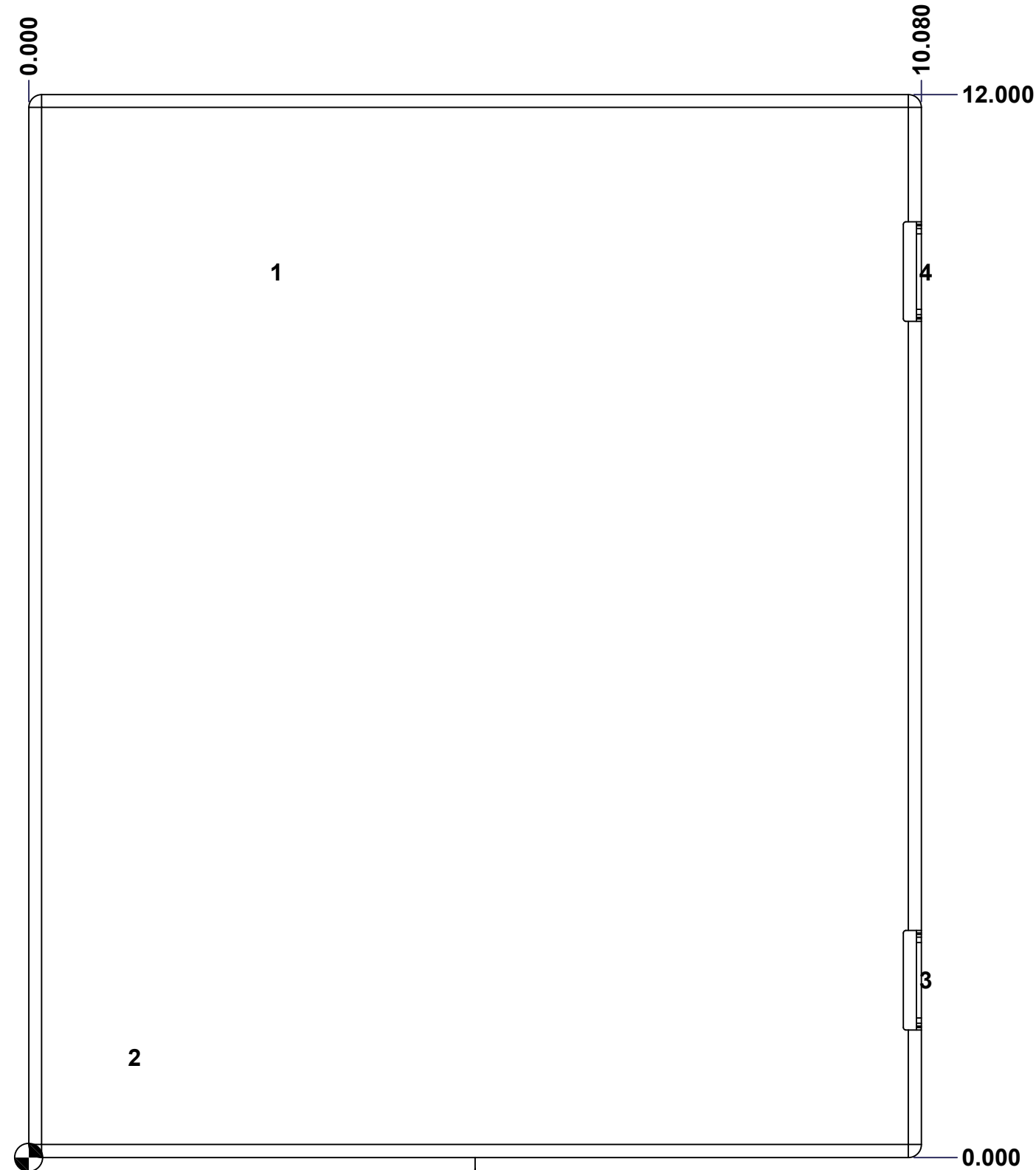

FRONT

	Description	Status
	5412EALCH 12" x 10" Cover	(NULL)
	Part Number Numéro Pièce	Rev.
	5412EALCH121005C	0
		8
		9

This drawing is confidential and must not be reproduced or used without the consent of EXM

Ce dessin est confidentiel et ne doit pas être reproduit ou utilisé sans le consentement de EXM

No.	Revisions	Date	By/Par

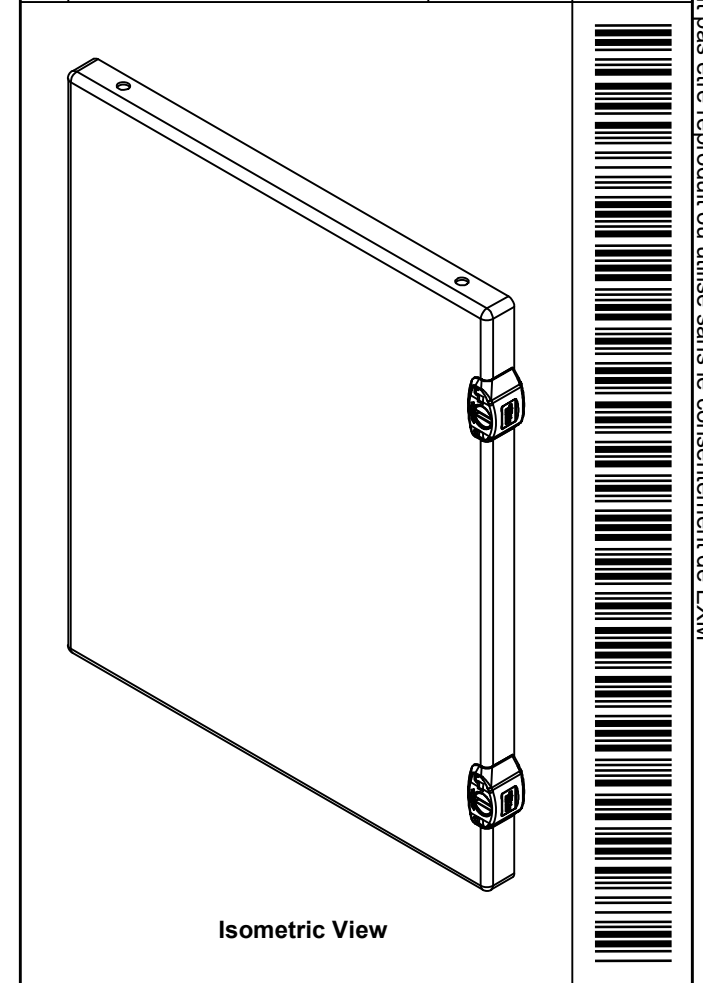

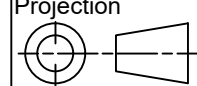
 Tél: (450) 979-4373 Fax: (450) 979-4626 www.exmweb.com		Flatness Aplatissement Max 3.0mm Projection 
Customer Client	Date	
Drawn By Dessiné Par	BoxCad: BoxCad	Date 19-Aug-14
Material Matière	Aluminum 5052-H32 (1.4mm)	
Color Couleur	Asa-61 Grey	Finish Fini Smooth
Description		Detail Rev.
5412EALCH 12" x 10" Cover		
Part Number Numéro Pièce	Rev.	9
5412EALCH121005C	0	9

Qty	Part Number	Rev	Description
1	5412EALCH121005G	0	5412EALCH 12" x 10" Gasket
1	STK-Q-08400	4	Aluminum Standoff M6 x 10mm
1	STK-S-00100	0	3.5" x 2" Silver Milar Flexcon Sticker
1	STK-P-02400S	0	Powder Paint (Asa-61 Grey / Smooth)
1	5412EALCH121005C-P	0	5412EALCH 12" x 10" Cover Part
2	STK-A-33038	5	5412 ESSCH Hinge Assembly
2	STK-A-79960	14	5412 ESMCH - External Lock Assy - Slot Lock
Parts List			

This drawing is confidential and must not be reproduced or used without the consent of EXM

Ce dessin est confidentiel et ne doit pas être reproduit ou utilisé sans le consentement de EXM

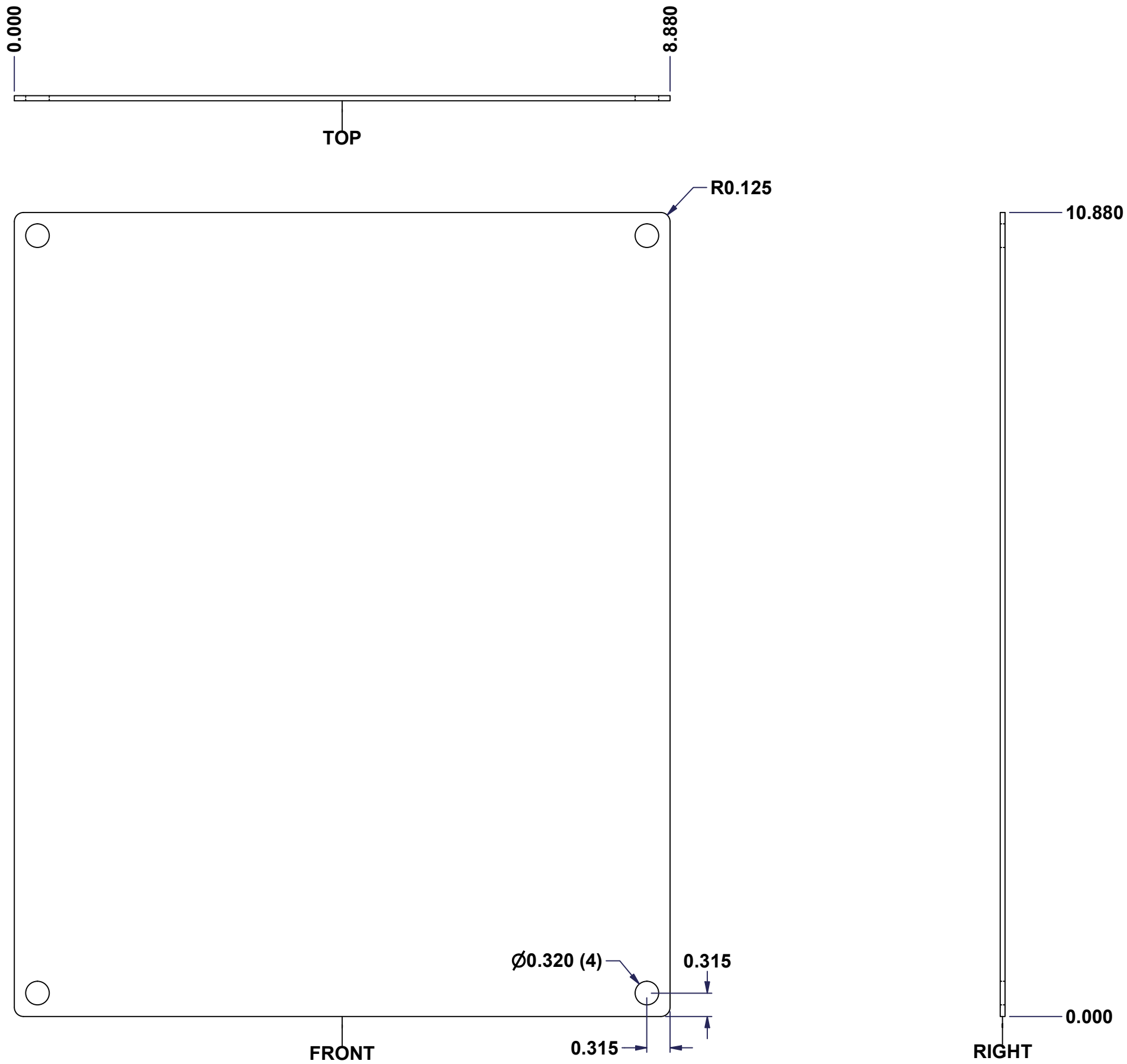

No.	Revisions	Date	By/Par

Isometric View

Tél: (450) 979-4373 Fax: (450) 979-4626 www.exmweb.com		Flatness Aplatissement Max 3.0mm Projection
Customer Client	Date	
Drawn By / Dessiné Par: BoxCad	Date: 23-Jan-07	
Material / Matière: 14 Ga Galvanized (1.7mm)		
Color / Couleur: Unpainted	Finish / Fini: Galvanized	
Description: 880 SP1210G - Inner Panel		Detail Rev.
Part Number / Numéro Pièce: 880 SP1210G	Rev. 0	1 / 2

SEE BILL OF MATERIAL ON LAST PAGE

This drawing is confidential and must not be reproduced or used without the consent of EXM

Ce dessin est confidentiel et ne doit pas être reproduit ou utilisé sans le consentement de EXM

No.	Revisions	Date	By/Par

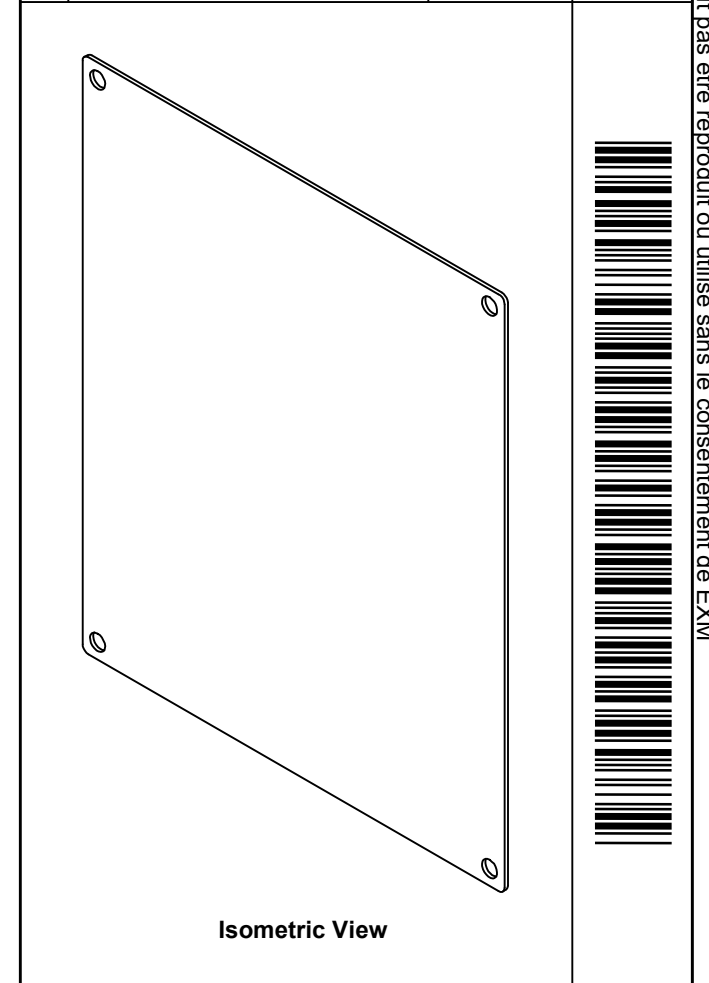

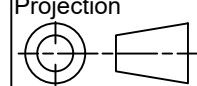
 Tél: (450) 979-4373 Fax: (450) 979-4626 www.exmweb.com		Flatness Aplatissement Max 3.0mm
Customer Client		Projection 
Drawn By Dessiné Par BoxCad		Date 23-Jan-07
Material Matière 14 Ga Galvanized (1.7mm)		
Color Couleur Unpainted	Finish Fini Galvanized	
Description 880 SP1210G - Inner Panel		Detail Rev.
Part Number Numéro Pièce 880 SP1210G		Rev. 0 / 2

Qty	Part Number	Rev	Description
1	880 SP1210G-P	0	880 SP1210G - Inner Panel Part
Parts List			