

This drawing is confidential and must not be reproduced or used without the consent of EXM

Ce dessin est confidentiel et ne doit pas être reproduit ou utilisé sans le consentement de EXM

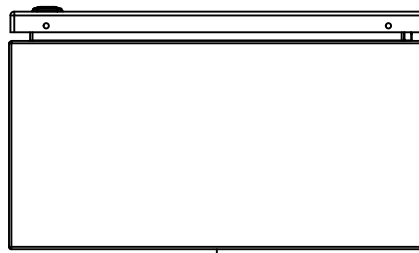

TOP

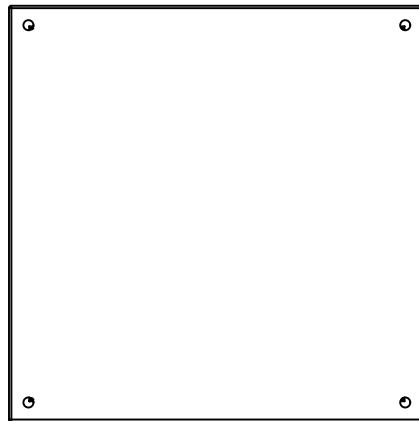

BACK

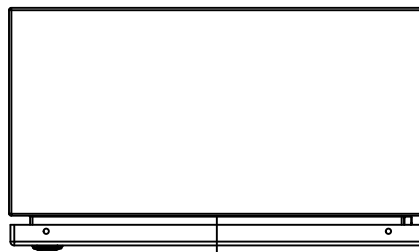

BOTTOM

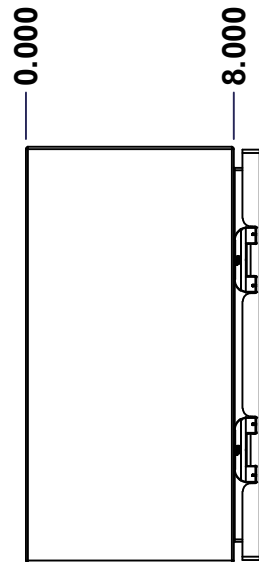

LEFT

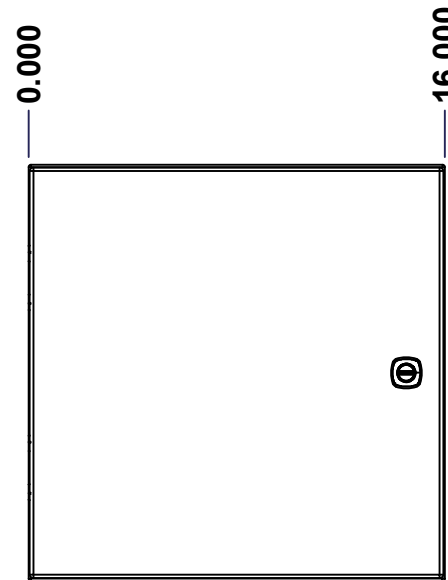

FRONT

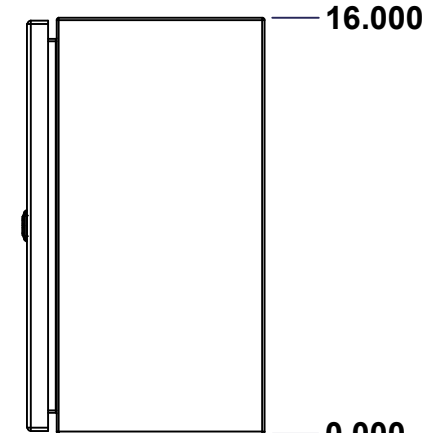

RIGHT

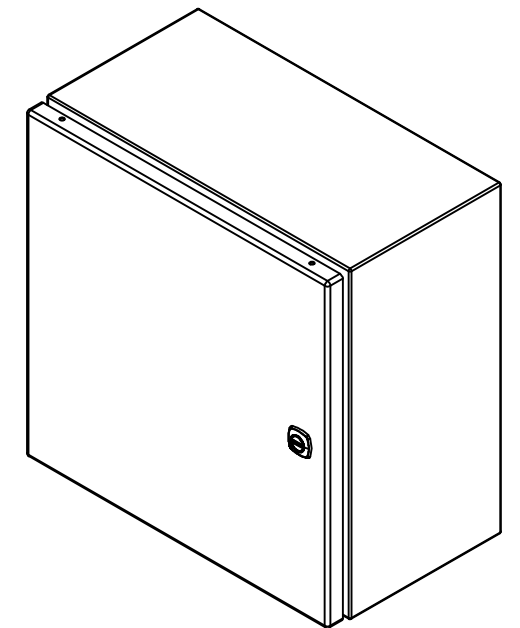

Isometric View

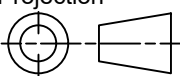

| No. | Revisions | Date | By/Par |
|-----|-----------|------|--------|
| | | | |
| | | | |
| | | | |
| | | | |

| | | |
|--|---|---|
|  Tél: (450) 979-4373 Fax: (450) 979-4626 www.exmweb.com | | Flatness Aplatissement Max 3.0mm Projection  |
| Customer Client | Date | |
| Drawn By Dessiné Par | BoxCad: BoxCad | Date 25-Oct-17 |
| Material Matière | 16 Ga Cold Rolled A1008 CS Type B (1.4mm) | |
| Color Couleur | Asa-61 Grey | Finish Fini Smooth |
| Description | Detail Rev. | |
| 5412ES 16" x 16" x 8" Assembly | | |
| Part Number Numéro Pièce | Rev. | 1 |
| 5412ES161608 | 0 | 9 |

SEE BILL OF MATERIAL ON LAST PAGE

This drawing is confidential and must not be reproduced or used without the consent of EXM

Ce dessin est confidentiel et ne doit pas être reproduit ou utilisé sans le consentement de EXM

| NOTE | |
|------|--|
| ITEM | DESCRIPTION |
| 1 | NEMA 4, 12 Enclosure (IP66) |
| 2 | C/W Standard ground studs on box and cover |
| 3 | C/W Standard door stiffener |
| 4 | C/W Standard inner panel (Included) |
| 5 | C/W Standard inner panel mounting studs |
| 6 | C/W 880 PP included (Not installed) |

| No. | Revisions | Date | By/Par |
|-----|-----------|------|--------|
| | | | |
| | | | |
| | | | |
| | | | |
| | | | |
| | | | |

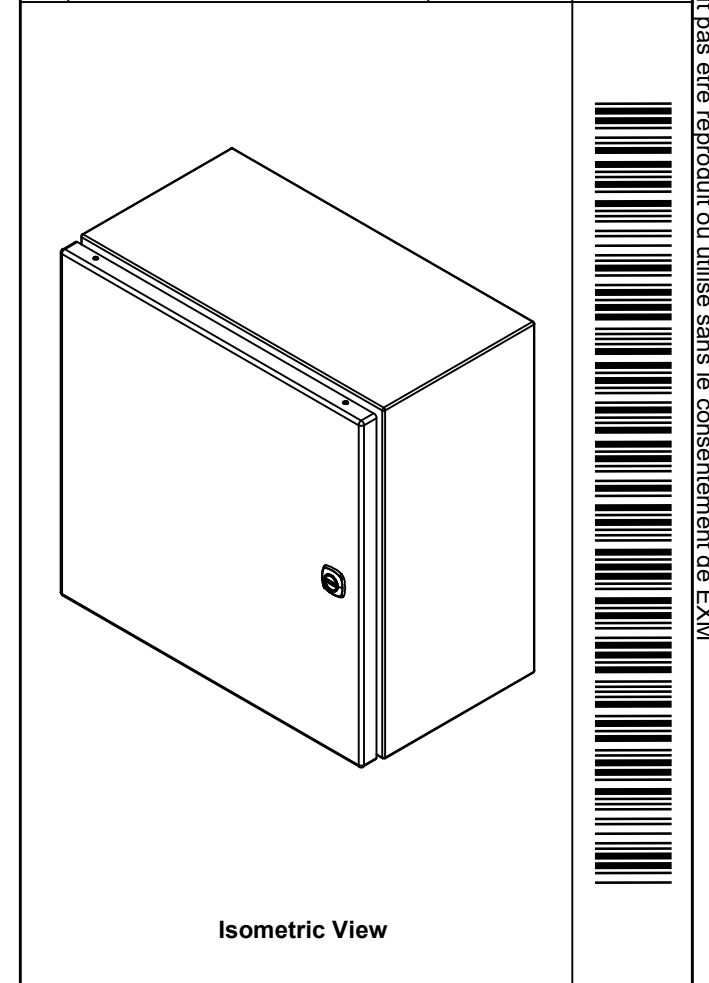

EXM
www.exmweb.com

Tél: (450) 979-4373
Fax: (450) 979-4626

Flatness
Aplatissement
Max 3.0mm

Projection

| | |
|--|-----------------|
| Customer Client | Date |
| Drawn By / Dessiné Par: BoxCad: BoxCad | Date: 25-Oct-17 |

Material / Matière: 16 Ga Cold Rolled A1008 CS Type B (1.4mm)

| | |
|------------------------------|-----------------------|
| Color / Couleur: Asa-61 Grey | Finish / Fini: Smooth |
|------------------------------|-----------------------|

Description: 5412ES 16" x 16" x 8" Assembly

Detail Rev.

| | | | |
|---|--------|---|---|
| Part Number / Numéro Pièce: 5412ES161608 | Rev. 0 | 2 | 9 |
|---|--------|---|---|

| PACKING | | |
|-----------------------|-----|--|
| ITEM | QTY | DESCRIPTION |
| Cardboard sleeve | 2 | Top and Bottom |
| Cardboard strip | 2 | Between back of enclosure and inner panel |
| Plastic bag | 1 | To protect cover surface and inside gasket |
| Plastic strap - Black | 2 | To Squeeze the 2 cardboard sleeve together |
| Packaging label | 1 | White label with product number |

| Qty | Part Number | Rev | Description |
|------------|----------------|-----|--|
| 1 | 881 SP1616G | 0 | 881 SP - Inner Panel |
| 2 | STK-K-01320 | 0 | 5412 ES Inner Panel Accessory Kit |
| 1 | 880 PP | 6 | Self Adhesive Print Pocket |
| 1 | STK-K-01800 | 5 | 5412 ES Accessory Kit |
| 1 | 5412ES161608C | 0 | 5412ES 16" x 16" Cover |
| 1 | 5412ES161608B | 0 | 5412ES 16" x 16" x 8" Body |
| 2 | STK-Q-04050-08 | 0 | M6 x 8mm Hexagon Socket Head Machine Screw |
| Parts List | | | |

This drawing is confidential and must not be reproduced or used without the consent of EXM

Ce dessin est confidentiel et ne doit pas être reproduit ou utilisé sans le consentement de EXM

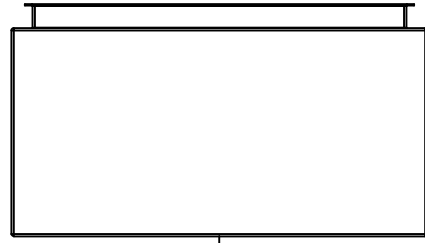

TOP

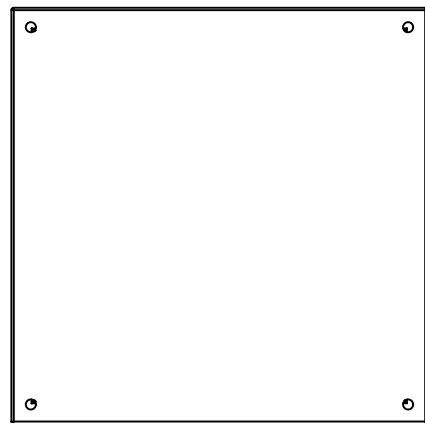

BACK

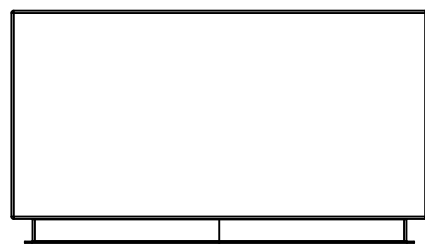

BOTTOM

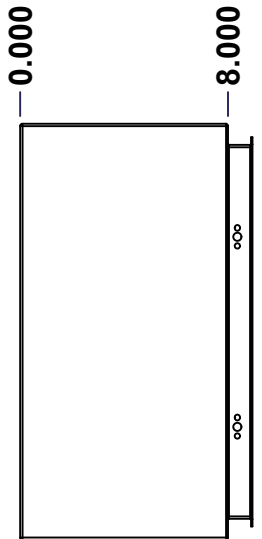

LEFT

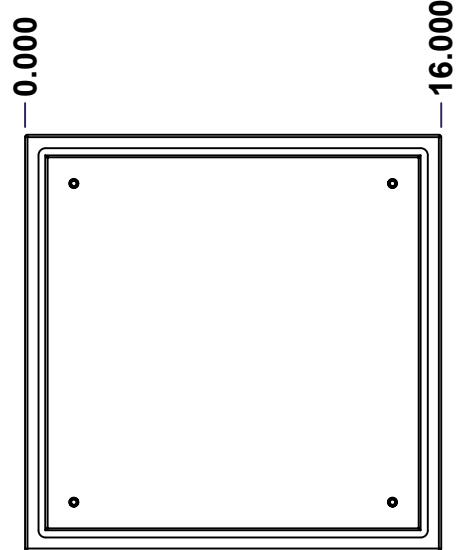

FRONT

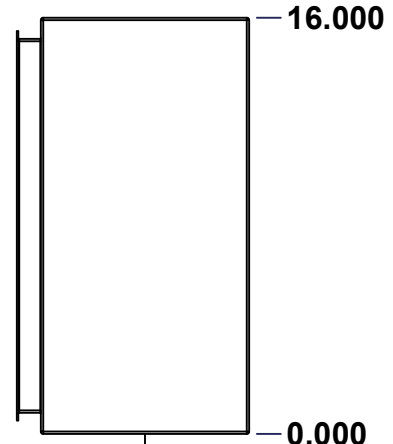

RIGHT

| No. | Revisions | Date | By/Par |
|-----|-----------|------|--------|
| | | | |
| | | | |
| | | | |
| | | | |

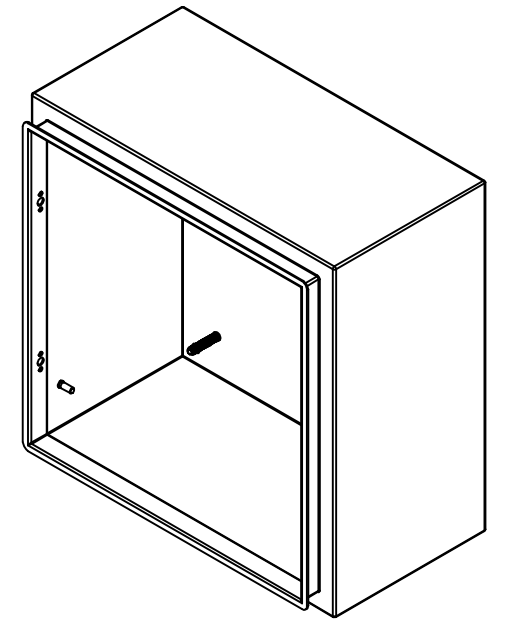

Isometric View

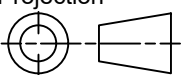

| | |
|--|---|
|  Tél: (450) 979-4373 Fax: (450) 979-4626 www.exmweb.com | Flatness Aplatissement Max 3.0mm |
| | Projection  |
| Customer Client | Date |
| Drawn By / Dessiné Par: BoxCad: BoxCad | Date: 25-Oct-17 |
| Material / Matière: 16 Ga Cold Rolled A1008 CS Type B (1.4mm) | |
| Color / Couleur: Asa-61 Grey | Finish / Fini: Smooth |
| Description: 5412ES 16" x 16" x 8" Body | Detail Rev. |
| Part Number / Numéro Pièce: 5412ES161608B | Rev. 0 |

SEE BILL OF MATERIAL ON LAST PAGE

3/9

This drawing is confidential and must not be reproduced or used without the consent of EXM

Ce dessin est confidentiel et ne doit pas être reproduit ou utilisé sans le consentement de EXM

STANDARD FEATURES ARE NOT LISTED IN THIS HOLE TABLE

HOLE TABLE - LEFT VIEW (CUSTOM FEATURE ONLY)

| CUT-OUT | XDIM | YDIM | DESCRIPTION |
|---------|-------|-------|-----------------------------|
| 1 | 6.500 | 2.000 | GND STUD M6 x 16mm (Inside) |

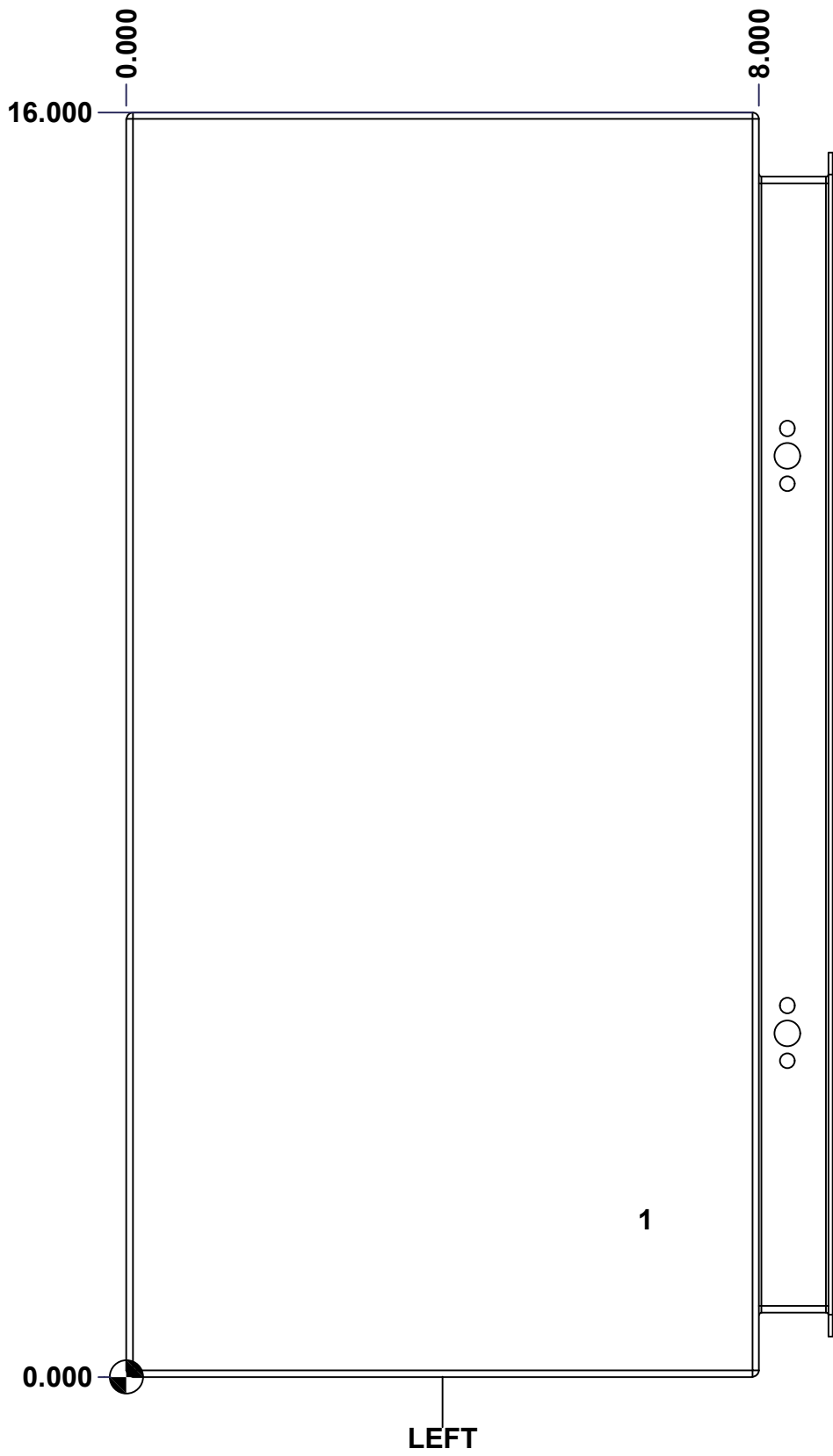

| | | | |
|--|-----------------------------|----------|--------|
| | Description | Status | |
| | 5412ES 16" x 16" x 8" Body | (NULL) | |
| | Part Number Numéro Pièce | Rev. | |
| | 5412ES161608B | 0 | 4 9 |

This drawing is confidential and must not be reproduced or used without the consent of EXM

Ce dessin est confidentiel et ne doit pas être reproduit ou utilisé sans le consentement de EXM

STANDARD FEATURES ARE NOT LISTED IN THIS HOLE TABLE

HOLE TABLE - BACK VIEW (CUSTOM FEATURE ONLY)

| CUT-OUT | XDIM | YDIM | DESCRIPTION |
|---------|--------|--------|----------------------------|
| 1 | 1.875 | 1.875 | IP STUD M8 x 35mm (Inside) |
| 2 | 1.875 | 14.125 | IP STUD M8 x 35mm (Inside) |
| 3 | 14.125 | 14.125 | IP STUD M8 x 35mm (Inside) |
| 4 | 14.125 | 1.875 | IP STUD M8 x 35mm (Inside) |
| ----- | | | |
| 5 | 0.750 | 15.250 | RND Ø0.390 |
| 6 | 0.750 | 0.750 | RND Ø0.390 |
| 7 | 15.250 | 0.750 | RND Ø0.390 |
| 8 | 15.250 | 15.250 | RND Ø0.390 |

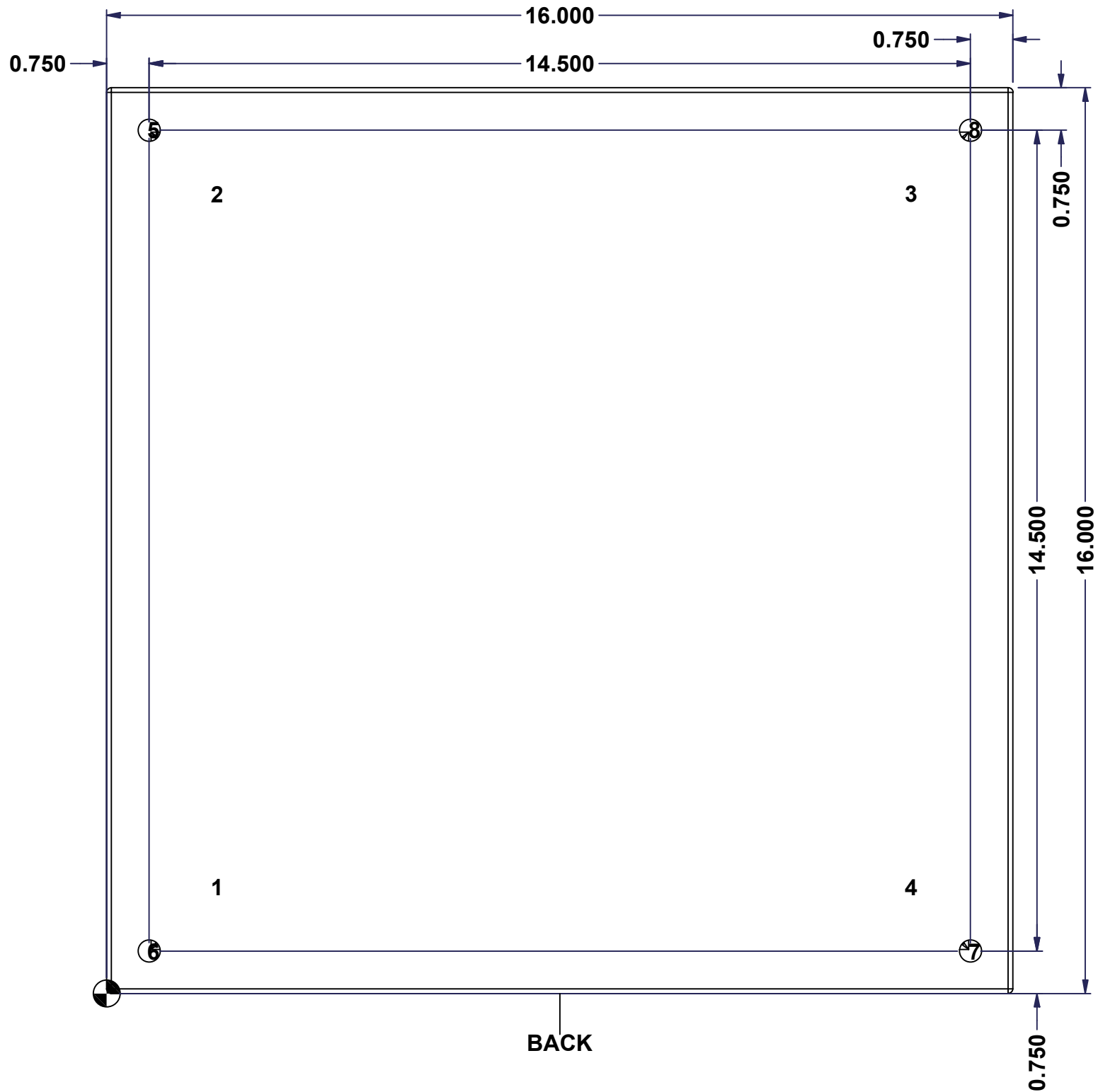

BACK

| | | |
|--|-----------------------------|-------------------|
| | Description | Status |
| | 5412ES 16" x 16" x 8" Body | (NULL) |
| | Part Number Numéro Pièce | Rev. |
| | 5412ES161608B | 0 / 5 9 |

This drawing is confidential and must not be reproduced or used without the consent of EXM

Ce dessin est confidentiel et ne doit pas être reproduit ou utilisé sans le consentement de EXM

| No. | Revisions | Date | By/Par |
|-----|-----------|------|--------|
| | | | |
| | | | |
| | | | |
| | | | |
| | | | |

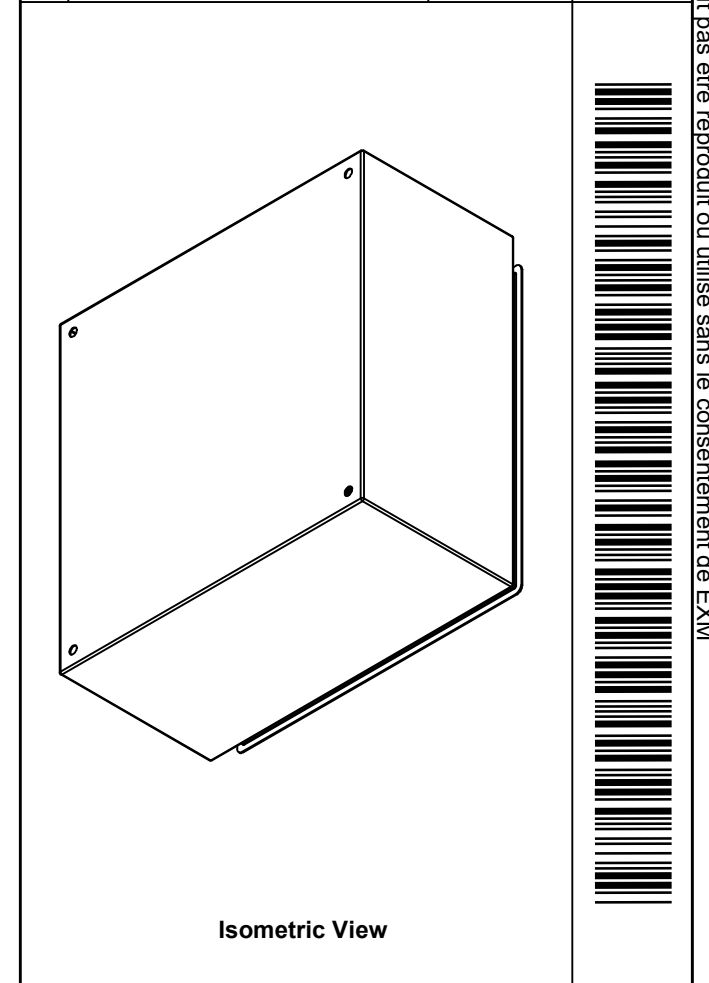

Isometric View

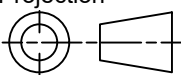

| | | |
|--|-----------------------|---|
|  Tél: (450) 979-4373 Fax: (450) 979-4626 www.exmweb.com | | Flatness Aplatissement Max 3.0mm Projection  |
| Customer Client | Date | |
| Drawn By / Dessiné Par: BoxCad: BoxCad | Date: 25-Oct-17 | |
| Material / Matière: 16 Ga Cold Rolled A1008 CS Type B (1.4mm) | | |
| Color / Couleur: Asa-61 Grey | Finish / Fini: Smooth | |
| Description: 5412ES 16" x 16" x 8" Body | | Detail Rev. |
| Part Number / Numéro Pièce: 5412ES161608B | Rev.: | 6 / 9 |

| Qty | Part Number | Rev | Description |
|------------|-----------------|-----|-------------------------------------|
| 1 | STK-Q-16080 | 0 | Ground Stud M6 x 16mm Steel |
| 1 | STK-P-02400S | 0 | Powder Paint (Asa-61 Grey / Smooth) |
| 4 | STK-Q-16005 | 0 | Stud M8 x 35mm Steel |
| 1 | 5412ES161608B-P | 0 | 5412ES 16" x 16" x 8" Body Part |
| Parts List | | | |

This drawing is confidential and must not be reproduced or used without the consent of EXM

Ce dessin est confidentiel et ne doit pas être reproduit ou utilisé sans le consentement de EXM

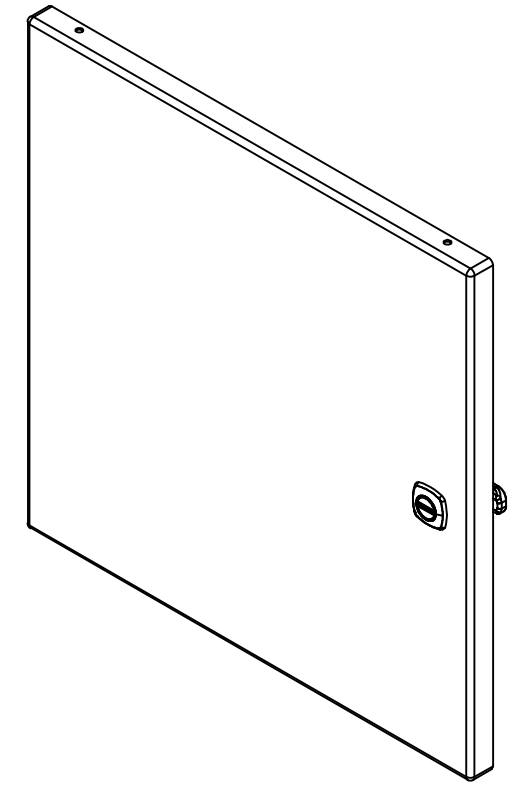
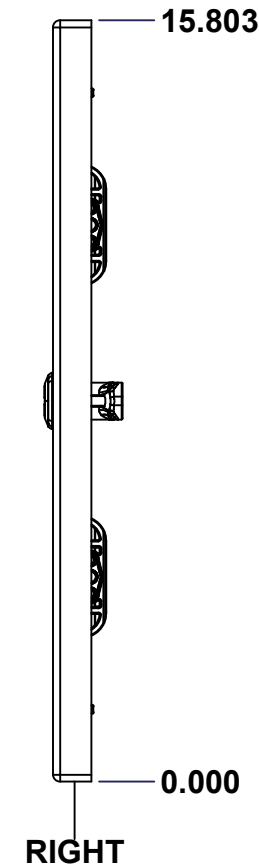
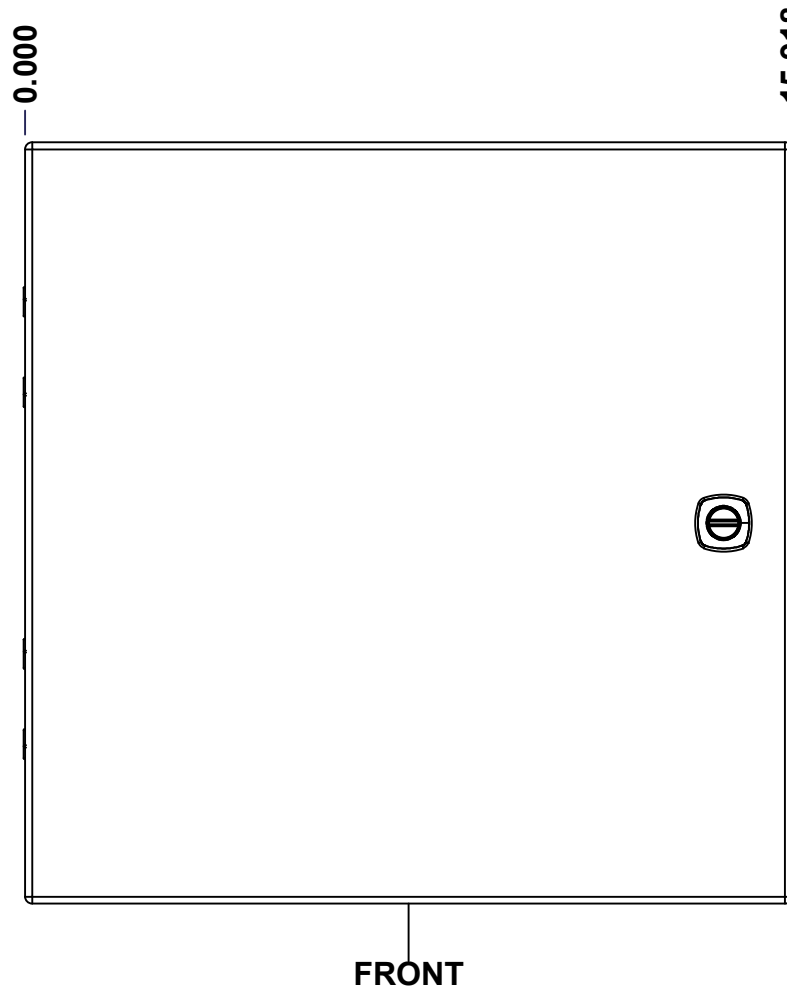
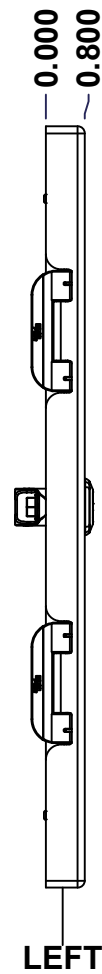
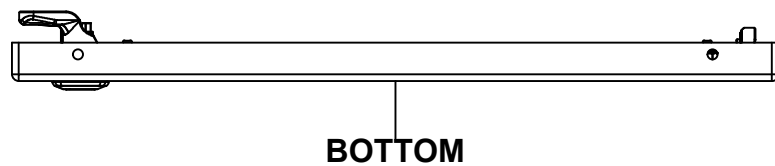
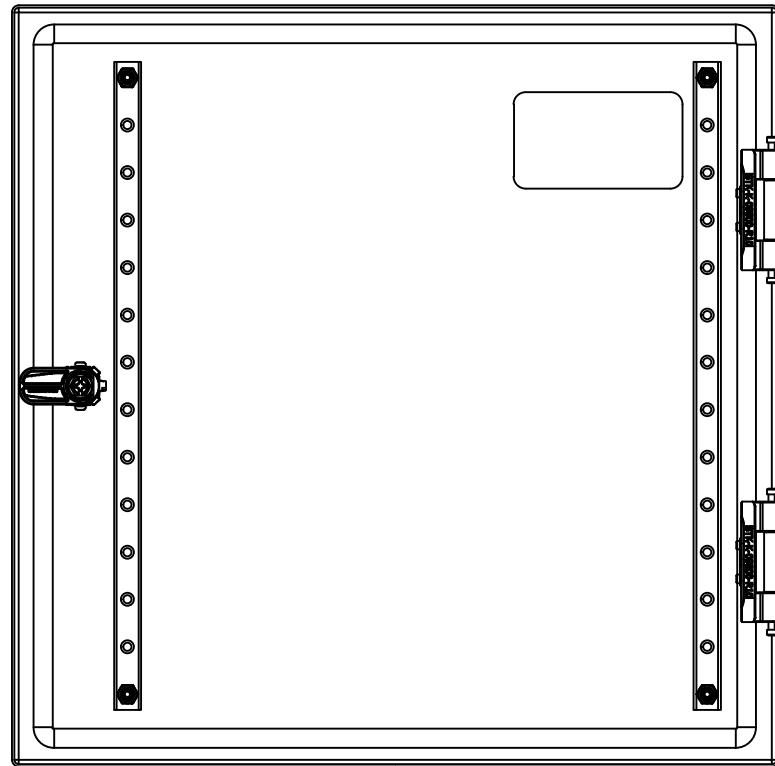
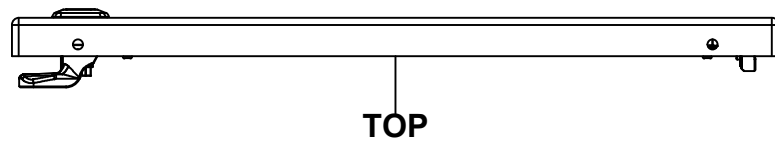

| No. | Revisions | Date | By/Par |
|-----|-----------|------|--------|
| | | | |
| | | | |
| | | | |
| | | | |

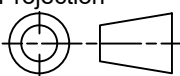
| | | |
|--|---|---|
|  Tél: (450) 979-4373 Fax: (450) 979-4626 www.exmweb.com | | Flatness Aplatissement Max 3.0mm Projection  |
| Customer Client | Date | |
| Drawn By Dessiné Par | BoxCad: BoxCad | Date 25-Oct-17 |
| Material Matière | 16 Ga Cold Rolled A1008 CS Type B (1.4mm) | |
| Color Couleur | Asa-61 Grey | Finish Fini Smooth |
| Description | Detail Rev. | |
| 5412ES 16" x 16" Cover | | |
| Part Number Numéro Pièce | Rev. 0 | 7 9 |

SEE BILL OF MATERIAL ON LAST PAGE

5412ES161608C

This drawing is confidential and must not be reproduced or used without the consent of EXM

Ce dessin est confidentiel et ne doit pas être reproduit ou utilisé sans le consentement de EXM

STANDARD FEATURES ARE NOT LISTED IN THIS HOLE TABLE

HOLE TABLE - FRONT VIEW (CUSTOM FEATURE ONLY)

| CUT-OUT | XDIM | YDIM | DESCRIPTION |
|---------|--------|--------|-------------------------|
| 1 | 1.486 | 1.504 | STUD M6 x 18mm (Inside) |
| 2 | 1.486 | 14.299 | STUD M6 x 18mm (Inside) |
| 3 | 13.517 | 14.299 | STUD M6 x 18mm (Inside) |
| 4 | 13.517 | 1.504 | STUD M6 x 18mm (Inside) |
| ----- | | | |
| 5 | 3.750 | 13.000 | LABEL_EXM (Inside) |
| 6 | 14.494 | 7.902 | LOCK 880 SCQ4-SL @ 0.0° |

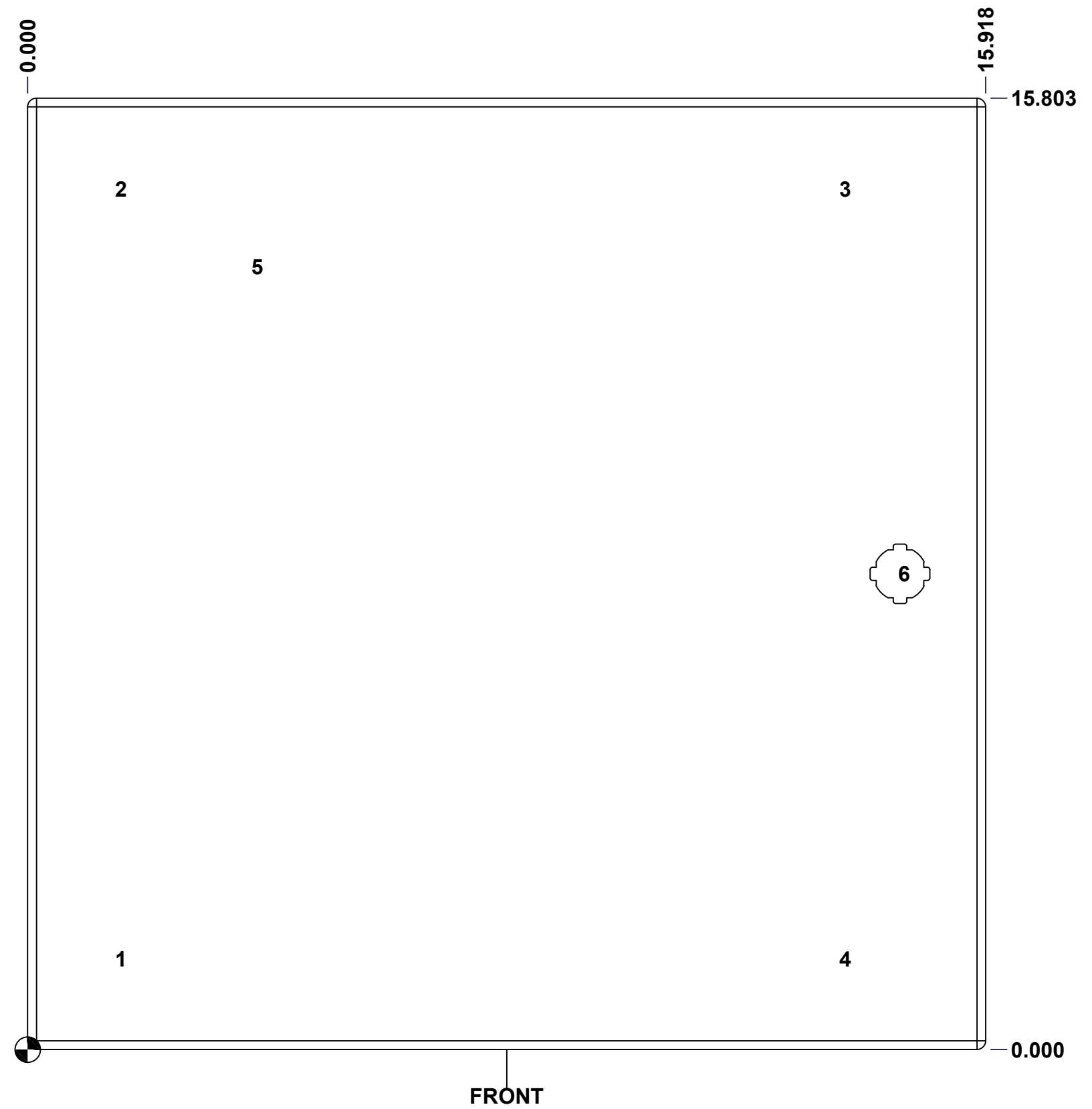

| | | | |
|--|-----------------------------|----------|--------|
| | Description | Status | |
| | 5412ES 16" x 16" Cover | (NULL) | |
| | Part Number Numéro Pièce | Rev. | |
| | 5412ES161608C | 0 | 8 9 |

This drawing is confidential and must not be reproduced or used without the consent of EXM

Ce dessin est confidentiel et ne doit pas être reproduit ou utilisé sans le consentement de EXM

| No. | Revisions | Date | By/Par |
|-----|-----------|------|--------|
| | | | |
| | | | |
| | | | |
| | | | |
| | | | |

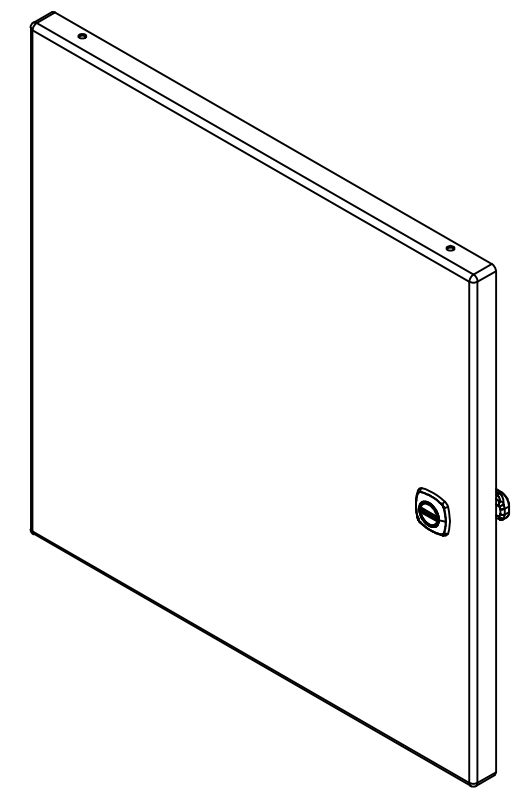

Isometric View

 Tél: (450) 979-4373
 Fax: (450) 979-4626
www.exmweb.com

Flatness / Aplatissement: Max 3.0mm
 Projection: 

| | |
|---|-----------------------|
| Customer Client | Date |
| Drawn By / Dessiné Par: BoxCad: BoxCad | Date: 25-Oct-17 |
| Material / Matière: 16 Ga Cold Rolled A1008 CS Type B (1.4mm) | |
| Color / Couleur: Asa-61 Grey | Finish / Fini: Smooth |

| QTY | Part Number | Rev | Description |
|-----|-----------------|-----|---|
| 1 | STK-K-12500 | 19 | 5412 ES 1/4 Turn Lock |
| 1 | STK-S-00100 | 0 | 3.5" x 2" Silver Milar Flexcon Sticker |
| 1 | STK-P-02400S | 0 | Powder Paint (Asa-61 Grey / Smooth) |
| 2 | STK-Q-46020-16 | 5 | 5412 ES Vertical Door Stiffener 16" |
| 4 | STK-Q-16055 | 1 | M6 x 18mm Stud (No Paint Cap Required) |
| 1 | 5412ES161608G | 0 | 5412ES 16" x 16" Cover Gasket Part |
| 1 | 5412ES161608C-P | 0 | 5412ES 16" x 16" Cover Part |
| 2 | STK-K-09800 | 10 | 5412 ES Hinge with 2 Captive Hinge Pins |
| 4 | STK-Q-07220 | 1 | M6 Nylon Insert Lock Nut |

| | |
|--|-------------|
| Description: 5412ES 16" x 16" Cover | Detail Rev. |
| Part Number / Numéro Pièce: 5412ES161608C | Rev. 0 |

| QTY | Part Number | Rev | Description |
|------------|-------------|-----|-------------|
| Parts List | | | |

| |
|----------|
| Rev. 9 |
| 0 |
| 9 |

This drawing is confidential and must not be reproduced or used without the consent of EXM

Ce dessin est confidentiel et ne doit pas être reproduit ou utilisé sans le consentement de EXM

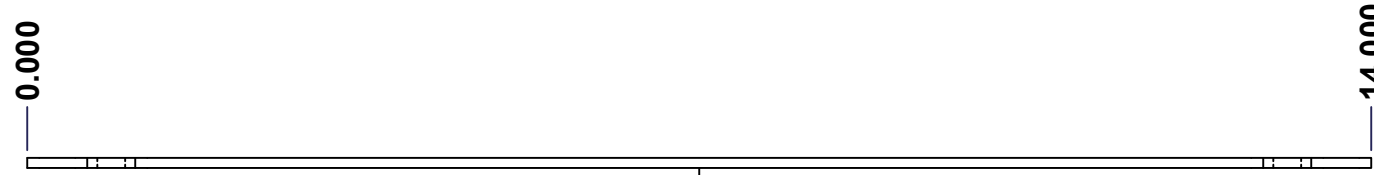

TOP

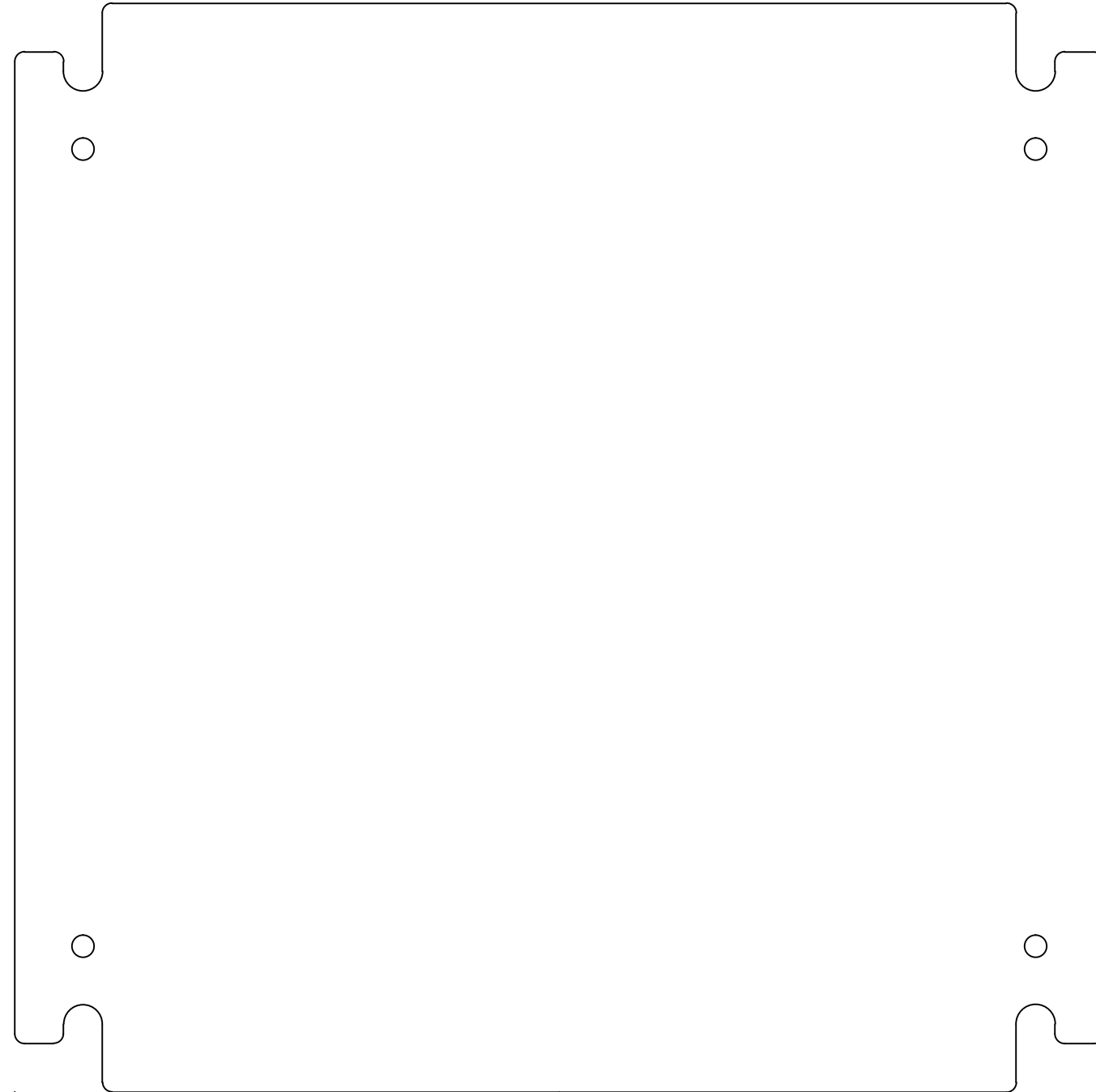

FRONT

14.000

0.000

RIGHT

| No. | Revisions | Date | By/Par |
|-----|-----------|------|--------|
| | | | |
| | | | |
| | | | |
| | | | |
| | | | |

Isometric View

| | |
|---|---|
| <p>Tél: (450) 979-4373 Fax: (450) 979-4626 www.exmweb.com</p> | <p>Flatness Aplatissement Max 3.0mm</p> |
| | <p>Projection</p> |
| Customer Client | Date |
| Drawn By Dessiné Par BoxCad | Date 23-Jan-07 |
| Material Matière | See Part List |
| Color Couleur | See Part List |
| Finish Fini | See Part List |
| Description | Detail Rev. |
| 881 SP - Inner Panel | |
| Part Number Numéro Pièce | Rev. 1 |
| 881 SP1616G | 0 2 |

| Qty | Part Number | Rev | Description | Material | Color | Finish |
|-----|---------------|-----|---------------------------|------------------|-----------|------------|
| 1 | 881 SP1616G-P | 0 | 881 SP - Inner Panel Part | 12 Ga Galvanized | Unpainted | Galvanized |

Parts List

This drawing is confidential and must not be reproduced or used without the consent of EXM

Ce dessin est confidentiel et ne doit pas être reproduit ou utilisé sans le consentement de EXM

| Table 1 | | | FRONT VIEW |
|---------|--------|--------|--------------------------|
| CUT-OUT | XDIM | YDIM | DESCRIPTION |
| 1 | 0.875 | 1.875 | GROUND HOLE (RND Ø0.290) |
| 2 | 13.125 | 1.875 | GROUND HOLE (RND Ø0.290) |
| 3 | 0.875 | 12.125 | GROUND HOLE (RND Ø0.290) |
| 4 | 13.125 | 12.125 | GROUND HOLE (RND Ø0.290) |

All knockouts are actual size / Les disques défonçables sont grandeur réel

| No. | Revisions | Date | By/Par |
|-----|-----------|------|--------|
| | | | |
| | | | |
| | | | |
| | | | |
| | | | |

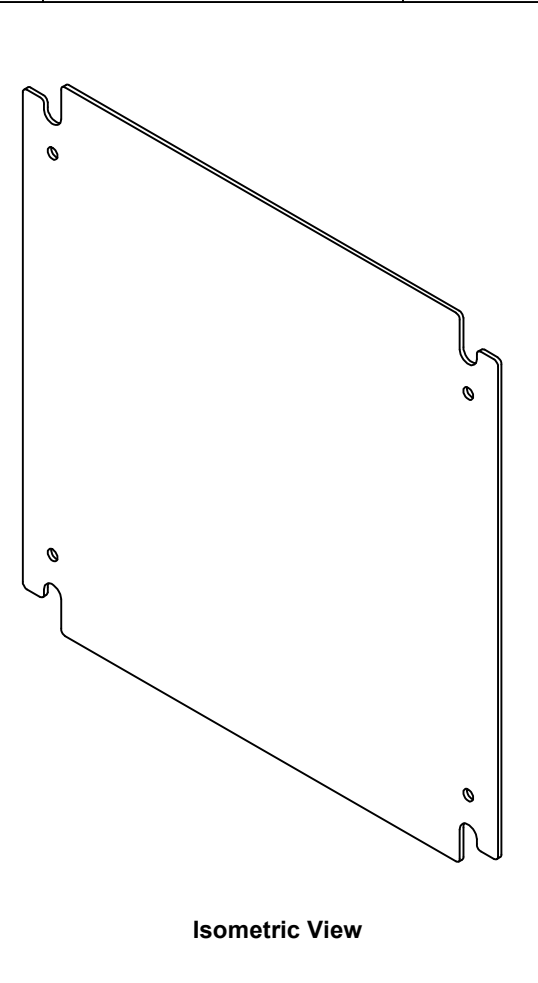
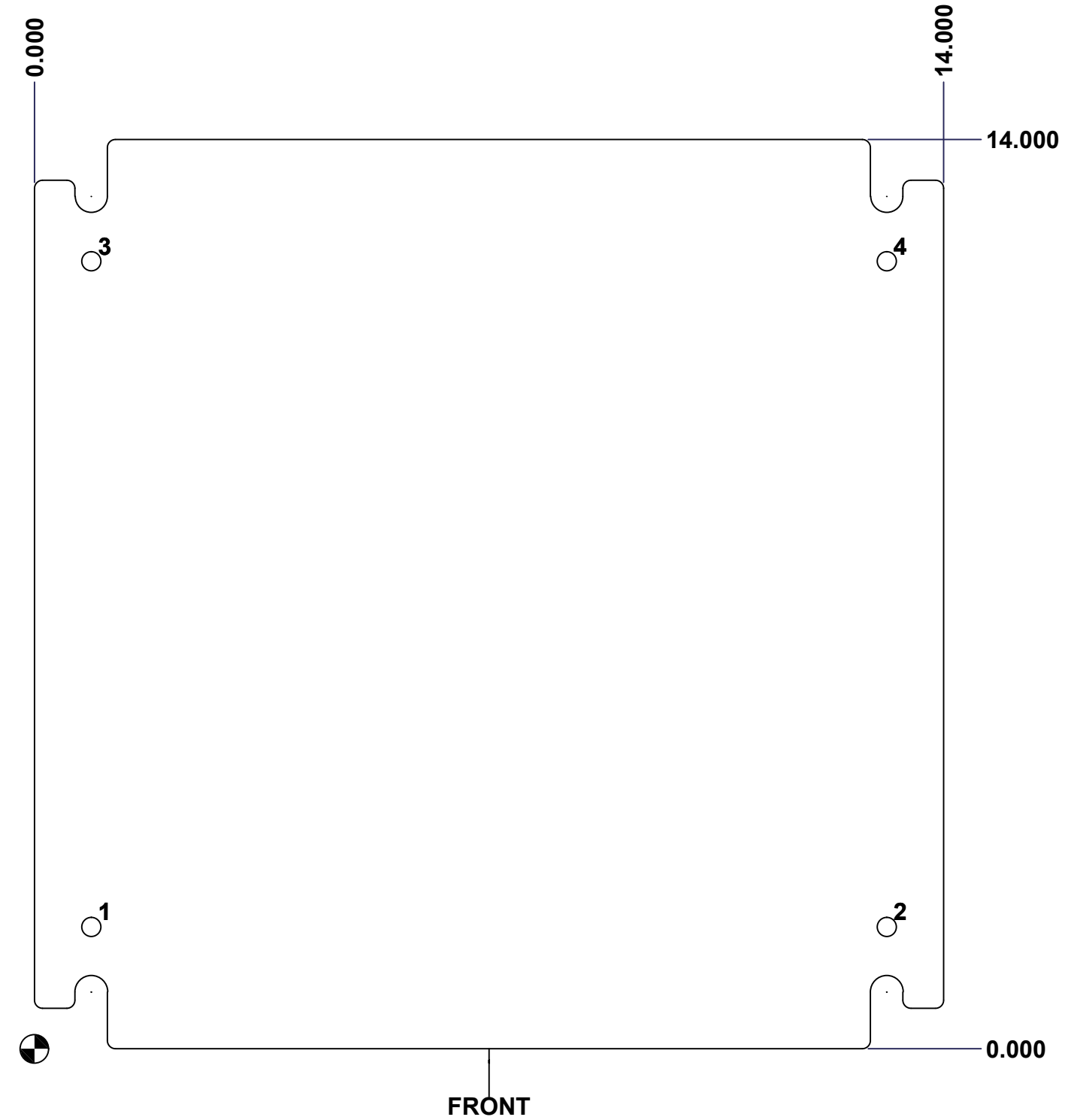

| | | |
|--|---------------|--|
| Tél: (450) 979-4373 Fax: (450) 979-4626 www.exmweb.com | | Flatness Aplatissement Max 3.0mm Projection |
| Customer Client | | Date |
| Drawn By Dessiné Par | BoxCad | Date 23-Jan-07 |
| Material Matière | See Part List | |
| Color Couleur | See Part List | Finish Fini See Part List |
| Description 881 SP - Inner Panel | | Detail Rev. |
| Part Number Numéro Pièce | 881 SP1616G | Rev. 2 0 |