

This drawing is confidential and must not be reproduced or used without the consent of EXM

Ce dessin est confidentiel et ne doit pas être reproduit ou utilisé sans le consentement de EXM

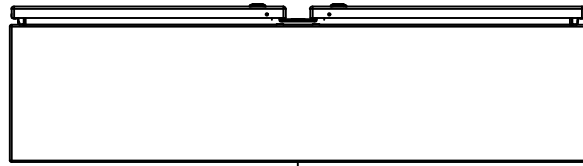

TOP



BACK

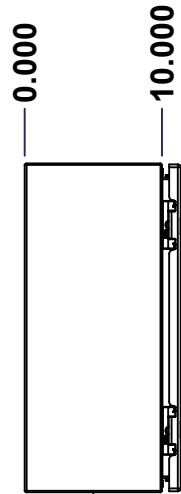

LEFT

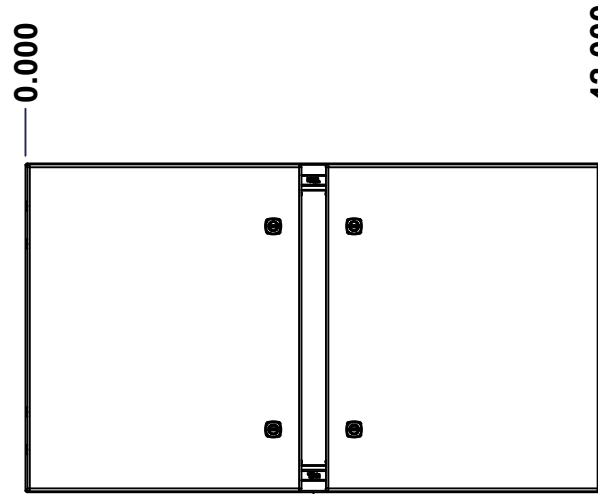

FRONT

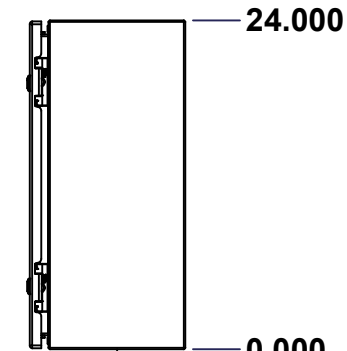

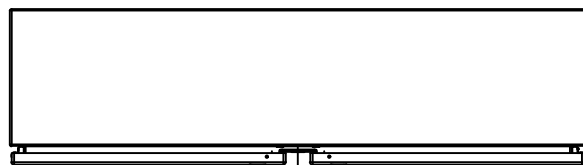

RIGHT

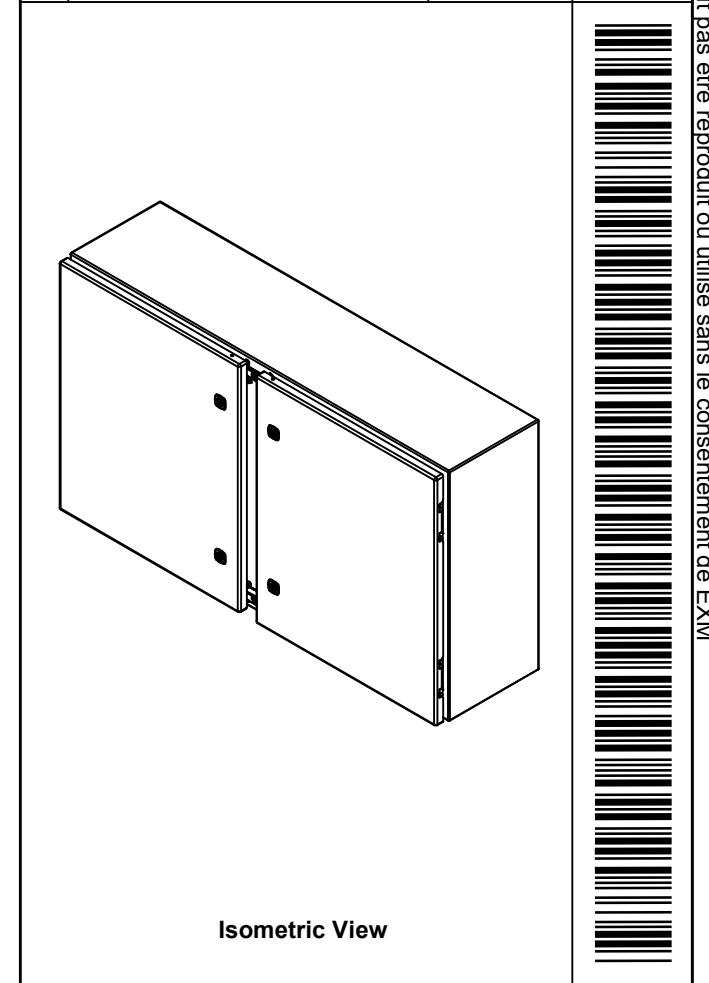

BOTTOM

No.	Revisions	Date	By/Par

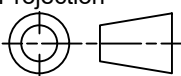

 Tél: (450) 979-4373 Fax: (450) 979-4626 <a href="http://www.exmweb.com">www.exmweb.com</a>		Flatness Aplatissement Max 3.0mm Projection 
Customer Client	Date	
Drawn By Dessiné Par	BoxCad: BoxCad	Date 23-Jan-26
Material Matière	12 Ga Cold Rolled A1008 CS Type B (2.5mm)	
Color Couleur	Asa-61 Grey	Finish Fini Smooth
Description 5412ESDDHD 24" x 42" x 10" Assembly		Detail Rev.
Part Number Numéro Pièce	Rev. 0	1 13

SEE BILL OF MATERIAL ON LAST PAGE

**5412ESDDHD244210**

This drawing is confidential and must not be reproduced or used without the consent of EXM

Ce dessin est confidentiel et ne doit pas être reproduit ou utilisé sans le consentement de EXM

NOTE	
ITEM	DESCRIPTION
1	NEMA 4, 12 Enclosure (IP66)
2	C/W Standard ground studs on box and cover
3	C/W Standard door stiffener
4	C/W Standard inner panel (Included)
5	C/W Standard inner panel mounting studs

No.	Revisions	Date	By/Par

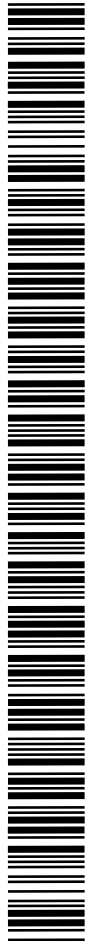
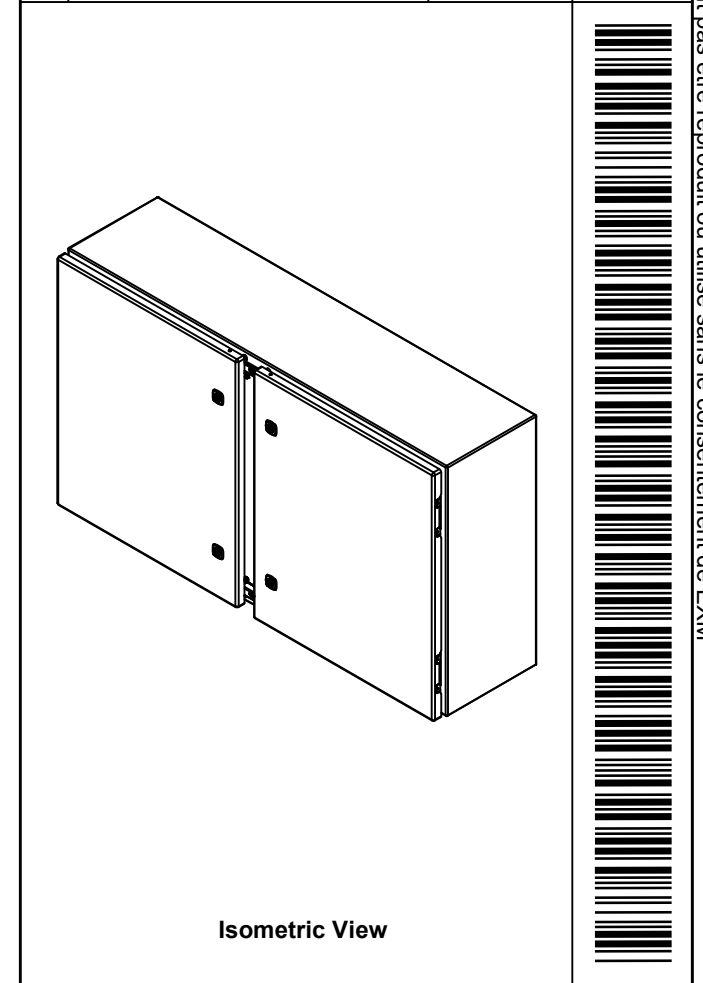

	Tél: (450) 979-4373 Fax: (450) 979-4626 <a href="http://www.exmweb.com">www.exmweb.com</a>	Flatness Aplatissement Max 3.0mm Projection 
	Customer Client Drawn By / Dessiné Par: BoxCad: BoxCad Material / Matière: 12 Ga Cold Rolled A1008 CS Type B (2.5mm)	Date Date: 23-Jan-26
Description: 5412ESDDHD 24" x 42" x 10" Assembly		Detail Rev.
Part Number / Numéro Pièce: <b>5412ESDDHD244210</b>		Rev. 0 / 2 / 13

PACKING		
ITEM	QTY	DESCRIPTION
Cardboard sleeve	2	Top and Bottom
Cardboard strip	2	Between back of enclosure and inner panel
Plastic bag	1	To protect cover surface and inside gasket
Plastic strap - Black	2	To Squeeze the 2 cardboard sleeve together
Packaging label	1	White label with product number

Qty	Part Number	Rev	Description
1	STK-K-01800	5	5412 ES Accessory Kit
1	885SP4224G	0	885SP 42" x 24" Inner Panel Part
3	STK-K-01320	0	5412 ES Inner Panel Accessory Kit
4	STK-Q-04050-10	8	M6 x 10mm Hexagon Socket Head Machine Screw with Nyseal
1	5412ESDDHD244210RD	0	5412ESDDHD 24" x 42" Cover
1	5412ESDDHD244210LD	0	5412ESDDHD 24" x 42" Cover
1	5412ESDDHD244210B	0	5412ESDDHD 24" x 42" x 10" Body
Parts List			

This drawing is confidential and must not be reproduced or used without the consent of EXM

Ce dessin est confidentiel et ne doit pas être reproduit ou utilisé sans le consentement de EXM

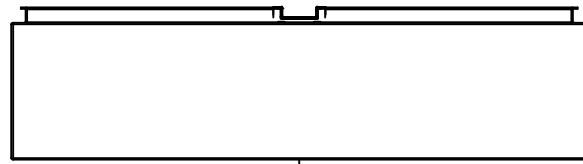

TOP

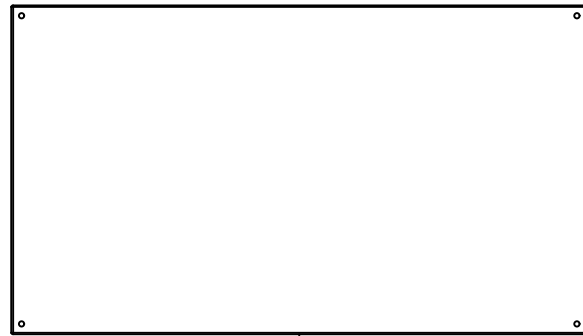

BACK

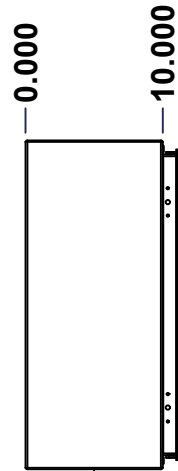

LEFT

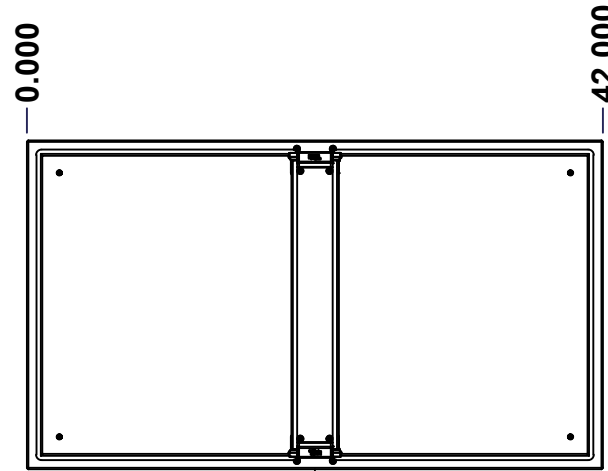

FRONT

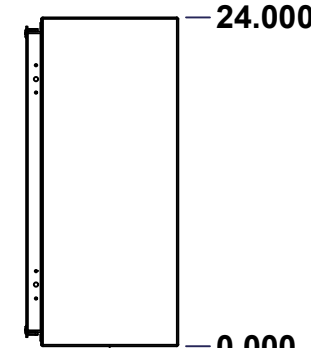

RIGHT

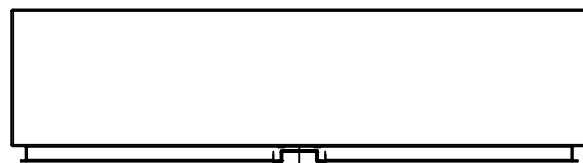

BOTTOM

No.	Revisions	Date	By/Par

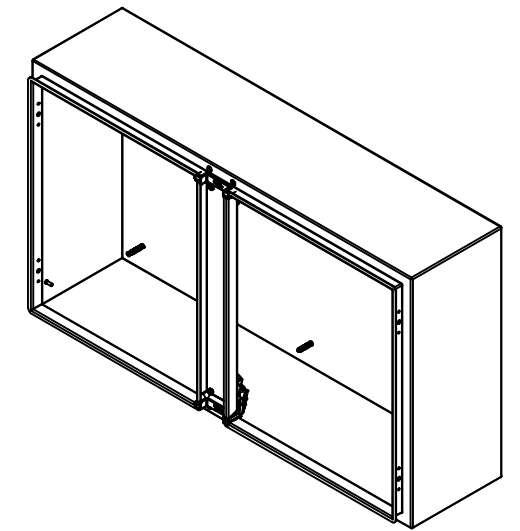

Isometric View



Tél: (450) 979-4373  
 Fax: (450) 979-4626  
[www.exmweb.com](http://www.exmweb.com)

Flatness  
Aplatissement

Max 3.0mm

Projection



Customer Client	Date
Drawn By / Dessiné Par: BoxCad: BoxCad	Date: 23-Jan-26
Material / Matière: 12 Ga Cold Rolled A1008 CS Type B (2.5mm)	

Color / Couleur: Asa-61 Grey	Finish / Fini: Smooth
------------------------------	-----------------------

Description: 5412ESDDHD 24" x 42" x 10" Body	Detail Rev.
--	-------------

Part Number / Numéro Pièce: 5412ESDDHD244210B	Rev. 0	3
---	--------	---

SEE BILL OF MATERIAL ON LAST PAGE

This drawing is confidential and must not be reproduced or used without the consent of EXM

Ce dessin est confidentiel et ne doit pas être reproduit ou utilisé sans le consentement de EXM

STANDARD FEATURES ARE NOT LISTED IN THIS HOLE TABLE			
HOLE TABLE - RIGHT VIEW (CUSTOM FEATURE ONLY)			
CUT-OUT	XDIM	YDIM	DESCRIPTION
1	8.500	2.000	GND STUD M6 x 16mm (Inside)

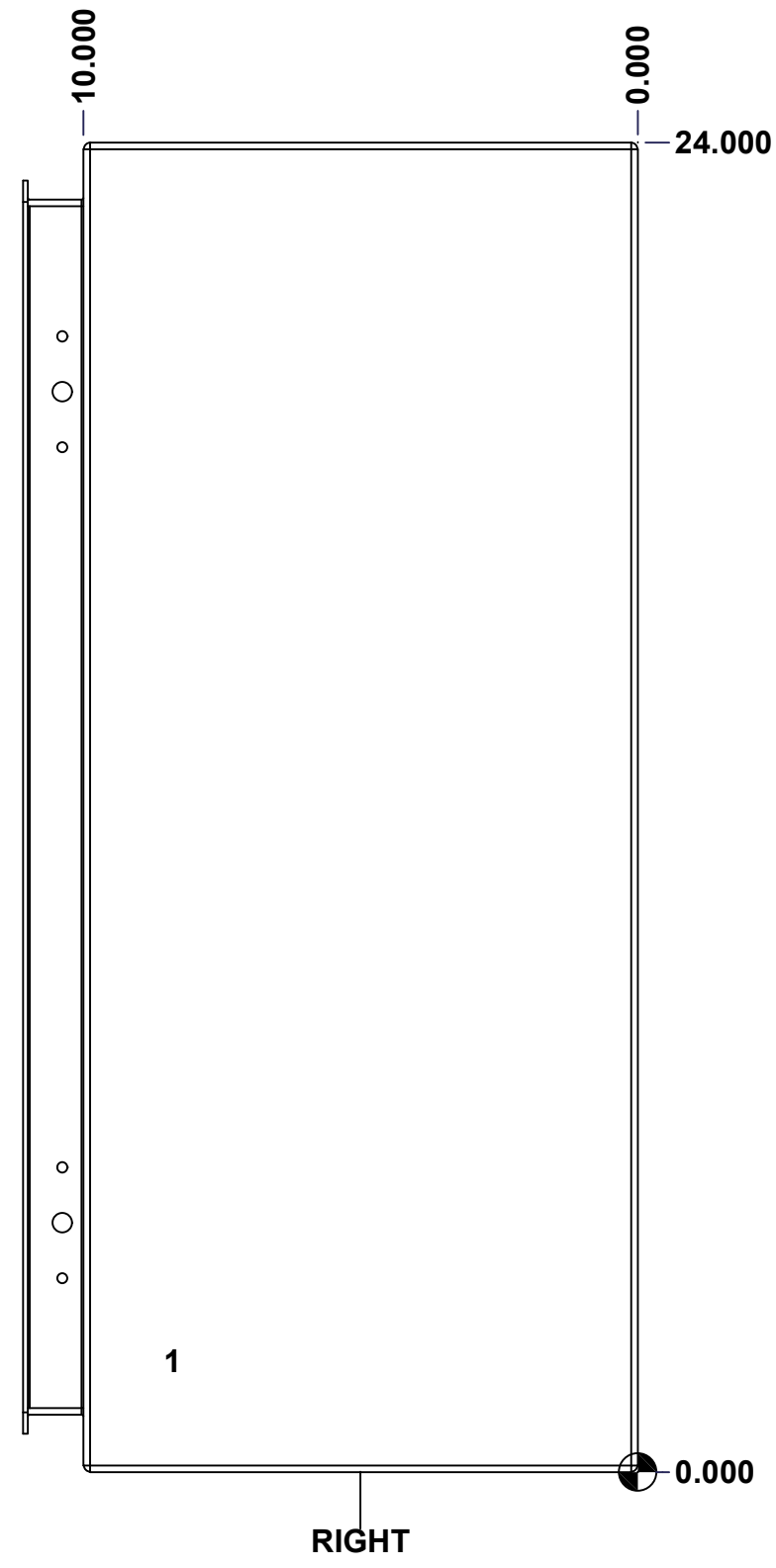

	Description	Status
	5412ESDDHD 24" x 42" x 10" Body	(NULL)
	Part Number Numéro Pièce	Rev.
	<b>5412ESDDHD244210B</b>	<b>0</b> / 4
		13

This drawing is confidential and must not be reproduced or used without the consent of EXM

Ce dessin est confidentiel et ne doit pas être reproduit ou utilisé sans le consentement de EXM

<b>STANDARD FEATURES ARE NOT LISTED IN THIS HOLE TABLE</b>			
<b>HOLE TABLE - LEFT VIEW (CUSTOM FEATURE ONLY)</b>			
CUT-OUT	XDIM	YDIM	DESCRIPTION
1	8.500	2.000	GND STUD M6 x 16mm (Inside)

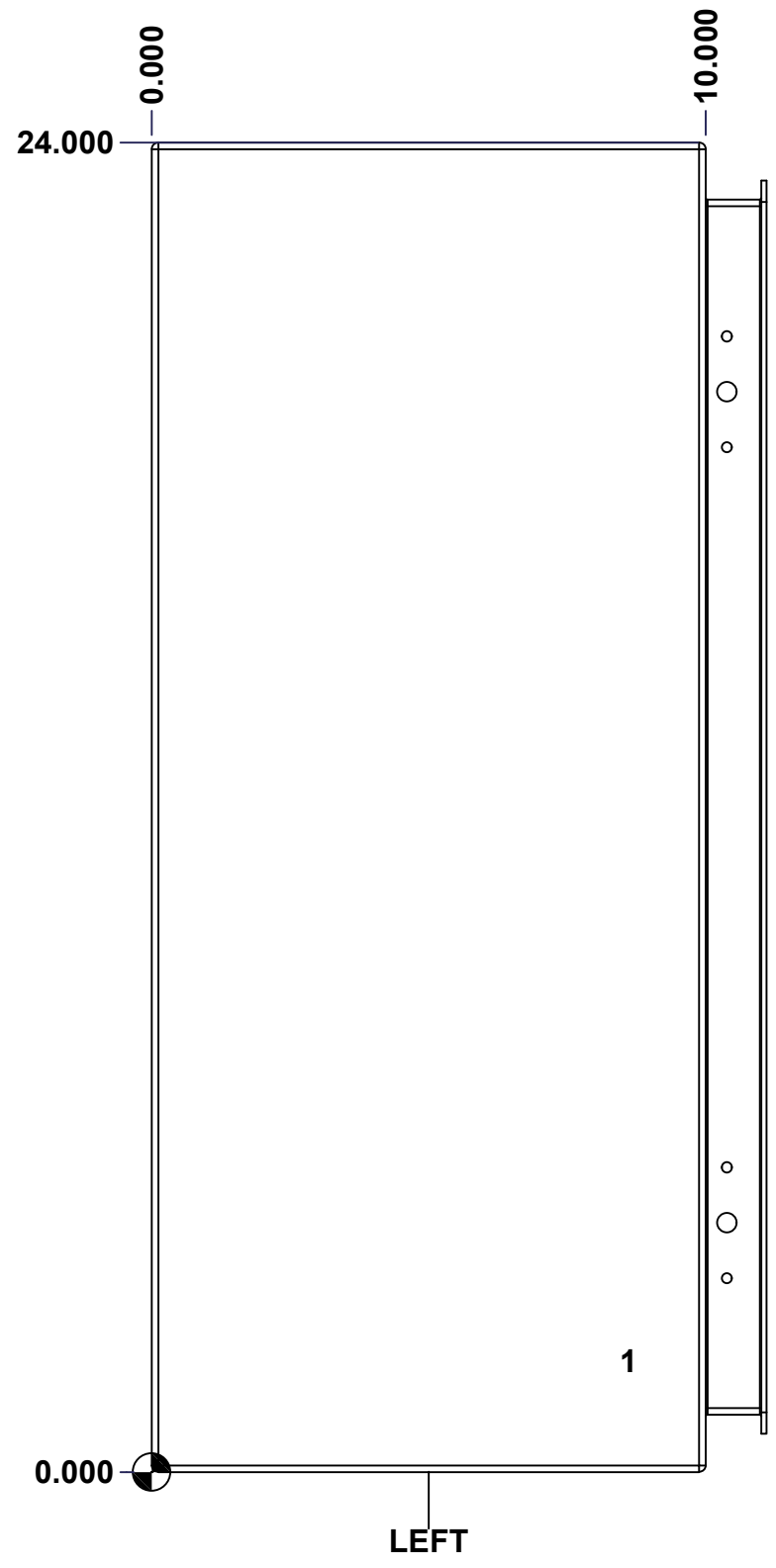

	Description	Status
	5412ESDDHD 24" x 42" x 10" Body	(NULL)
	Part Number Numéro Pièce	Rev.
	<b>5412ESDDHD244210B</b>	<b>0</b> / 5
		13

This drawing is confidential and must not be reproduced or used without the consent of EXM

Ce dessin est confidentiel et ne doit pas être reproduit ou utilisé sans le consentement de EXM

**STANDARD FEATURES ARE NOT LISTED IN THIS HOLE TABLE**

**HOLE TABLE - BACK VIEW (CUSTOM FEATURE ONLY)**

CUT-OUT	XDIM	YDIM	DESCRIPTION
1	2.375	2.375	IP STUD M8 x 35mm (Inside)
2	2.375	21.625	IP STUD M8 x 35mm (Inside)
3	39.625	21.625	IP STUD M8 x 35mm (Inside)
4	39.625	2.375	IP STUD M8 x 35mm (Inside)
5	21.000	2.375	IP STUD M8 x 35mm (Inside)
6	21.000	21.625	IP STUD M8 x 35mm (Inside)
-----			
7	0.750	0.750	RND Ø0.390
8	0.750	23.250	RND Ø0.390
9	41.250	0.750	RND Ø0.390
10	41.250	23.250	RND Ø0.390

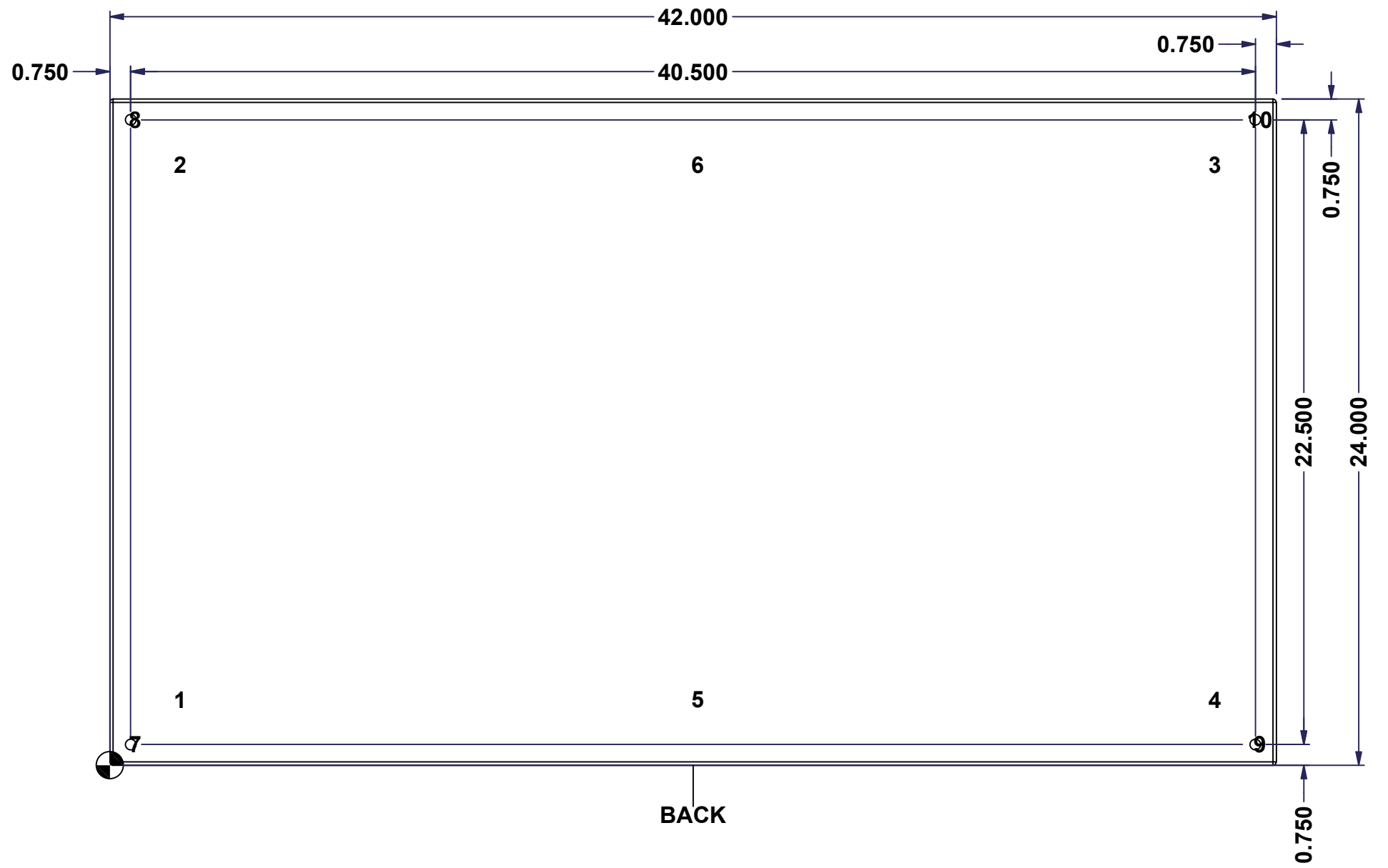



	Description	Status
	5412ESDDHD 24" x 42" x 10" Body	(NULL)
	Part Number	Rev.
	5412ESDDHD244210B	0
		6
		13

This drawing is confidential and must not be reproduced or used without the consent of EXM

Ce dessin est confidentiel et ne doit pas être reproduit ou utilisé sans le consentement de EXM

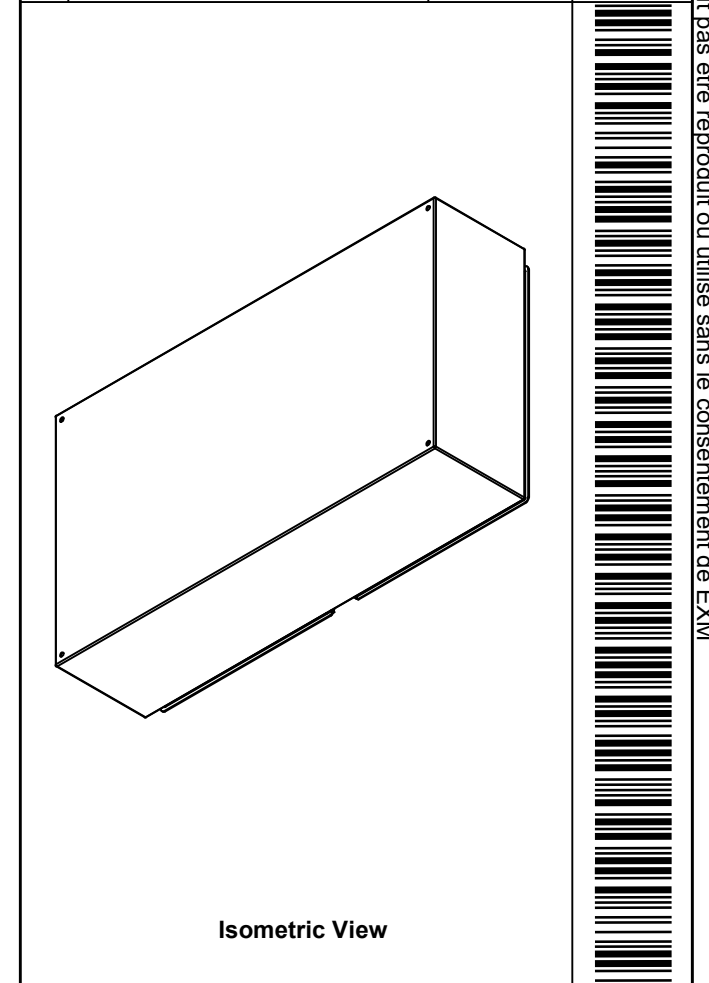
No.	Revisions	Date	By/Par

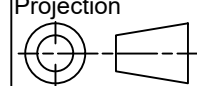

 Tél: (450) 979-4373 Fax: (450) 979-4626 <a href="http://www.exmweb.com">www.exmweb.com</a>		Flatness Aplatissement Max 3.0mm Projection 
Customer Client	Date	
Drawn By Dessiné Par	BoxCad: BoxCad	Date 23-Jan-26
Material Matière	12 Ga Cold Rolled A1008 CS Type B (2.5mm)	
Color Couleur	Asa-61 Grey	Finish Fini Smooth
Description		Detail Rev.
5412ESDDHD 24" x 42" x 10" Body		
Part Number Numéro Pièce	Rev. 0	7 / 13
<b>5412ESDDHD244210B</b>		

Qty	Part Number	Rev	Description
2	STK-Q-16080	0	Ground Stud M6 x 16mm Steel
1	STK-P-02400S	0	Powder Paint (Asa-61 Grey / Smooth)
6	STK-Q-16005	1	Stud M8 x 35mm (No Paint Cap Required)
8	STK-Q-04056-12	0	M6 x 8mm Hexagon Socket Head Machine Screw with Nyseal
1	STK-K-75454	14	Center Post Freestanding Sealing Block with Latch Kit
1	5412ESDDHD244210CP-P	0	5412ESDDHD 24" Center Post Part
1	5412ESDDHD244210B-P	0	5412ESDDHD 24" x 42" x 10" Body Part
Parts List			

This drawing is confidential and must not be reproduced or used without the consent of EXM

Ce dessin est confidentiel et ne doit pas être reproduit ou utilisé sans le consentement de EXM

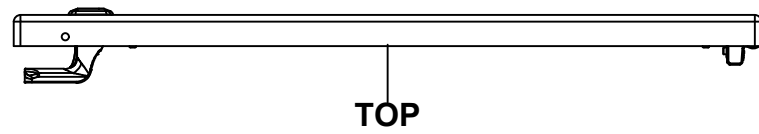

TOP

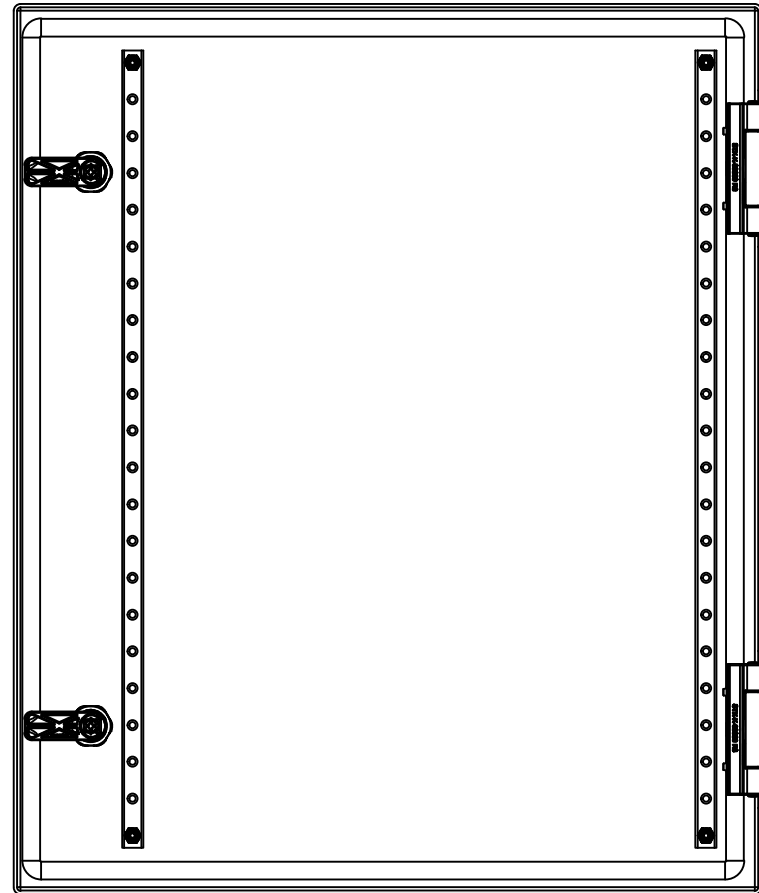

BACK

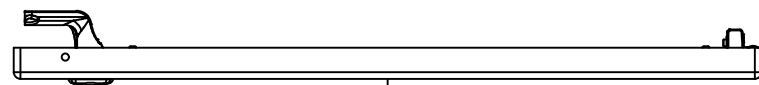

BOTTOM

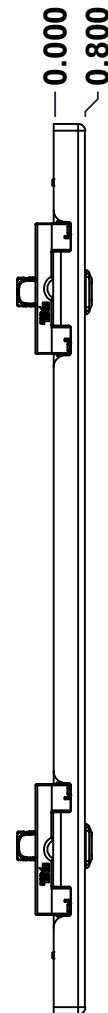

LEFT

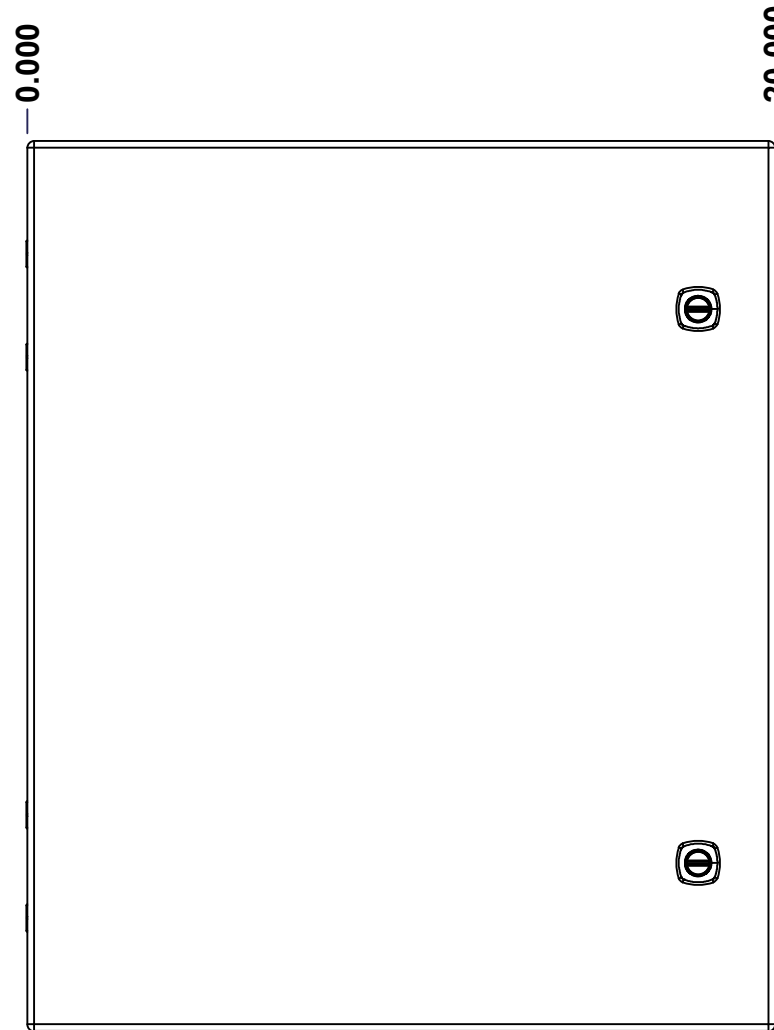

FRONT

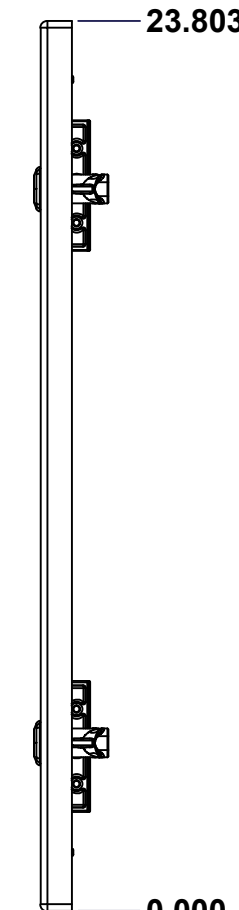

RIGHT

No.	Revisions	Date	By/Par

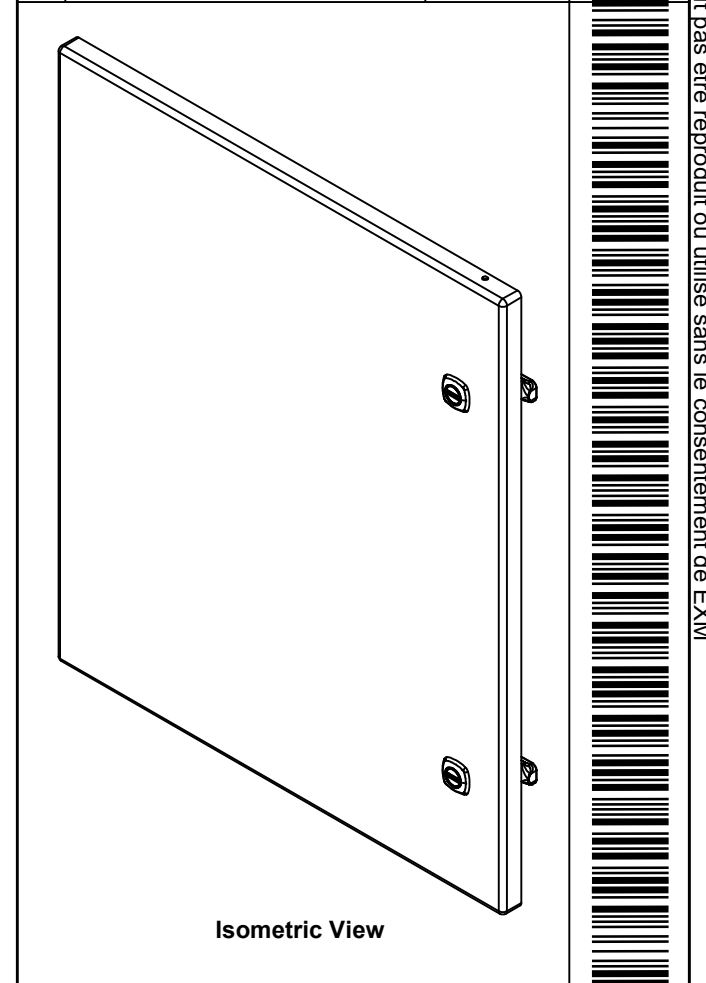

Isometric View

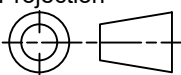
 Tél: (450) 979-4373 Fax: (450) 979-4626 <a href="http://www.exmweb.com">www.exmweb.com</a>		Flatness Aplatissement Max 3.0mm Projection 
Customer Client	Date	
Drawn By Dessiné Par	BoxCad: BoxCad	Date 23-Jan-26
Material Matière	12 Ga Cold Rolled A1008 CS Type B (2.5mm)	
Color Couleur	Asa-61 Grey	Finish Fini Smooth
Description	Detail Rev.	
5412ESDDHD 24" x 42" Cover		
Part Number Numéro Pièce	Rev. 0	8 / 13

SEE BILL OF MATERIAL ON LAST PAGE

**5412ESDDHD244210LD**

This drawing is confidential and must not be reproduced or used without the consent of EXM

Ce dessin est confidentiel et ne doit pas être reproduit ou utilisé sans le consentement de EXM

STANDARD FEATURES ARE NOT LISTED IN THIS HOLE TABLE			
HOLE TABLE - FRONT VIEW (CUSTOM FEATURE ONLY)			
CUT-OUT	XDIM	YDIM	DESCRIPTION
1	1.486	1.567	STUD M6 x 18mm (Inside)
2	1.486	22.236	STUD M6 x 18mm (Inside)
3	16.819	22.236	STUD M6 x 18mm (Inside)
4	16.819	1.567	STUD M6 x 18mm (Inside)
-----			
5	17.938	4.496	LOCK 889 SCQ4-SL @ 0.0°
6	17.938	19.308	LOCK 889 SCQ4-SL @ 0.0°

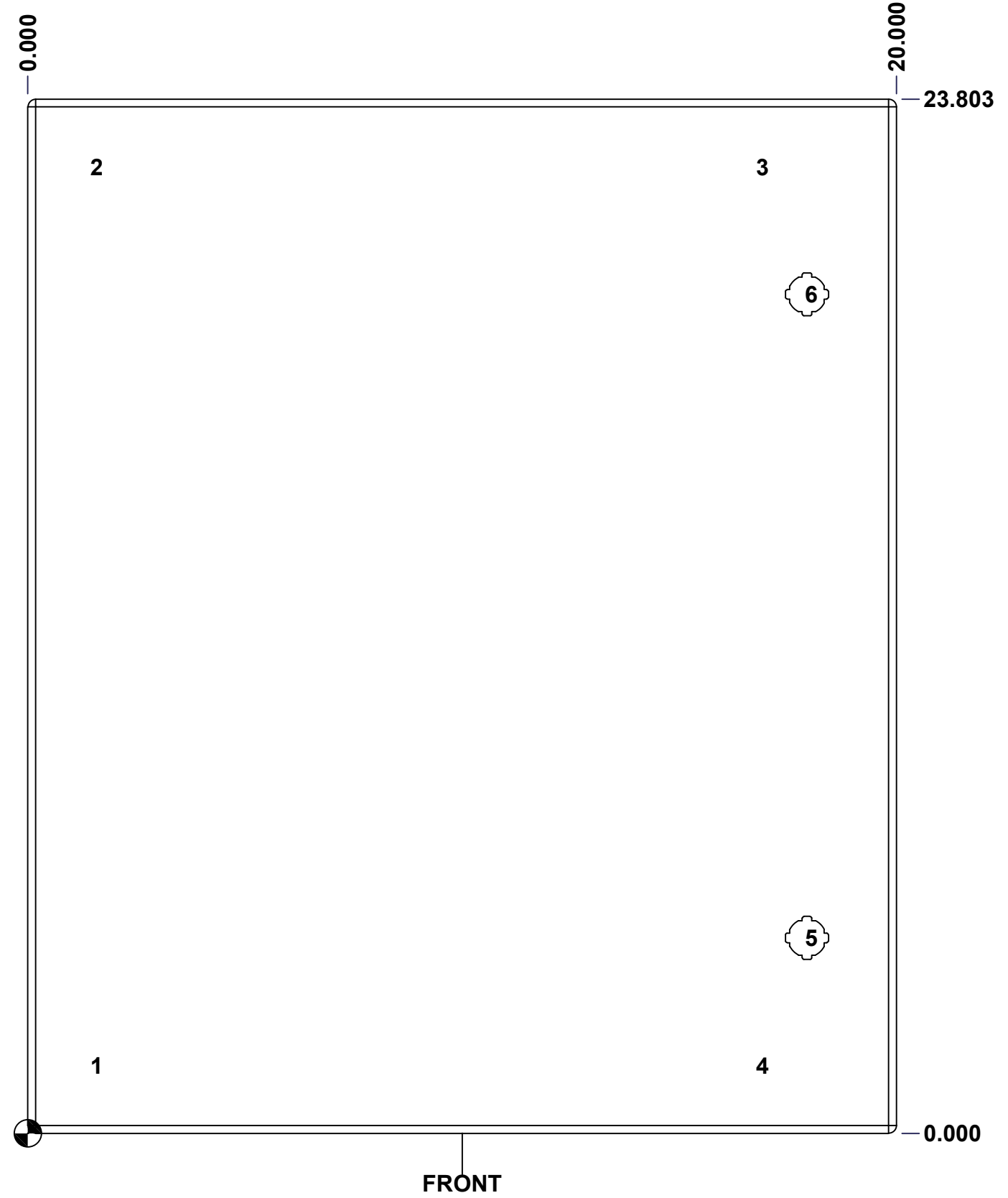

	Description	Status
	5412ESDDHD 24" x 42" Cover	(NULL)
	Part Number Numéro Pièce	Rev.
	<b>5412ESDDHD244210LD</b>	<b>0</b>
		9
		13

This drawing is confidential and must not be reproduced or used without the consent of EXM

Ce dessin est confidentiel et ne doit pas être reproduit ou utilisé sans le consentement de EXM

No.	Revisions	Date	By/Par

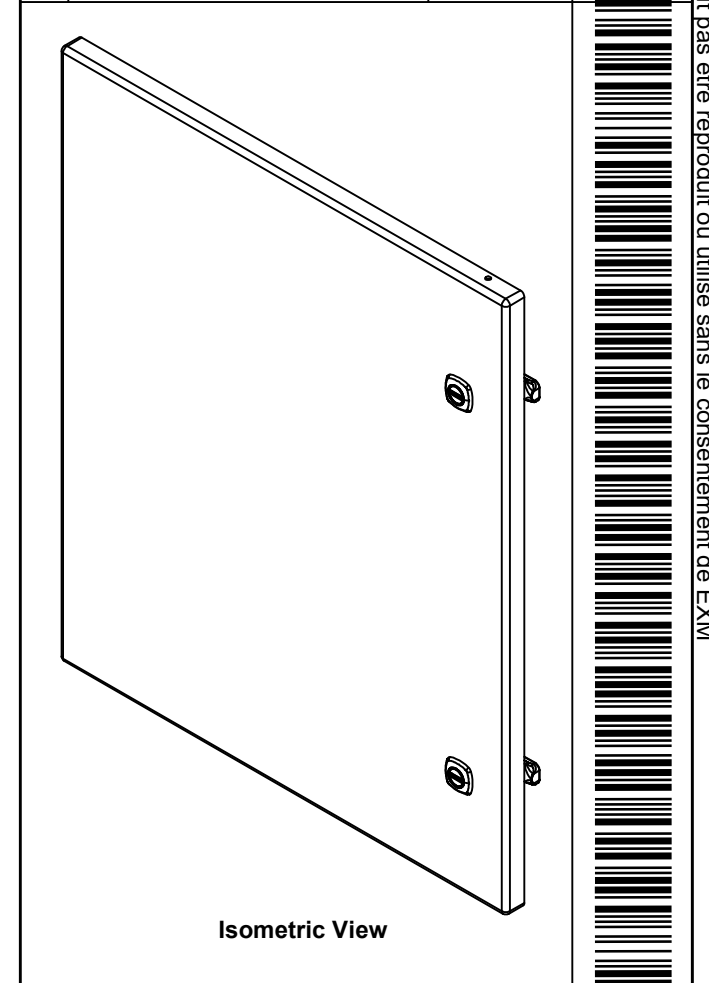

 Tél: (450) 979-4373  
 Fax: (450) 979-4626  
[www.exmweb.com](http://www.exmweb.com)

Flatness / Aplatissement: Max 3.0mm  
 Projection: 

2	STK-K-12580	0	9412 1/4 Turn Lock
1	STK-P-02400S	0	Powder Paint (Asa-61 Grey / Smooth)
4	STK-Q-07220	1	M6 Nylon Insert Lock Nut
2	STK-Q-46020-24	5	5412 ES Vertical Door Stiffener 24"
4	STK-Q-16055	1	M6 x 18mm Stud (No Paint Cap Required)
2	STK-K-09860	7	Cabinet Hinge with Captive Pins
1	5412ESDDHD244210LD-G	0	5412ESDDHD 24" x 20" Cover Gasket Part
1	5412ESDDHD244210LD-P	0	5412ESDDHD 24" x 42" Cover Part
QTY	Part Number	Rev	Description
Parts List			

Customer Client	Date
Drawn By / Dessiné Par: BoxCad: BoxCad	Date: 23-Jan-26
Material / Matière: 12 Ga Cold Rolled A1008 CS Type B (2.5mm)	
Color / Couleur: Asa-61 Grey	Finish / Fini: Smooth
Description: 5412ESDDHD 24" x 42" Cover	Detail Rev.:
Part Number / Numéro Pièce: <b>5412ESDDHD244210LD</b>	Rev. 0
	10 / 13

This drawing is confidential and must not be reproduced or used without the consent of EXM

Ce dessin est confidentiel et ne doit pas être reproduit ou utilisé sans le consentement de EXM

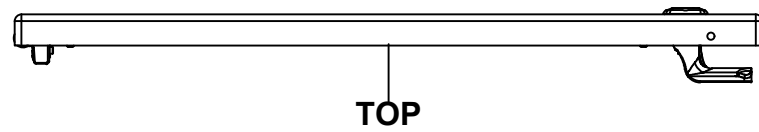

TOP

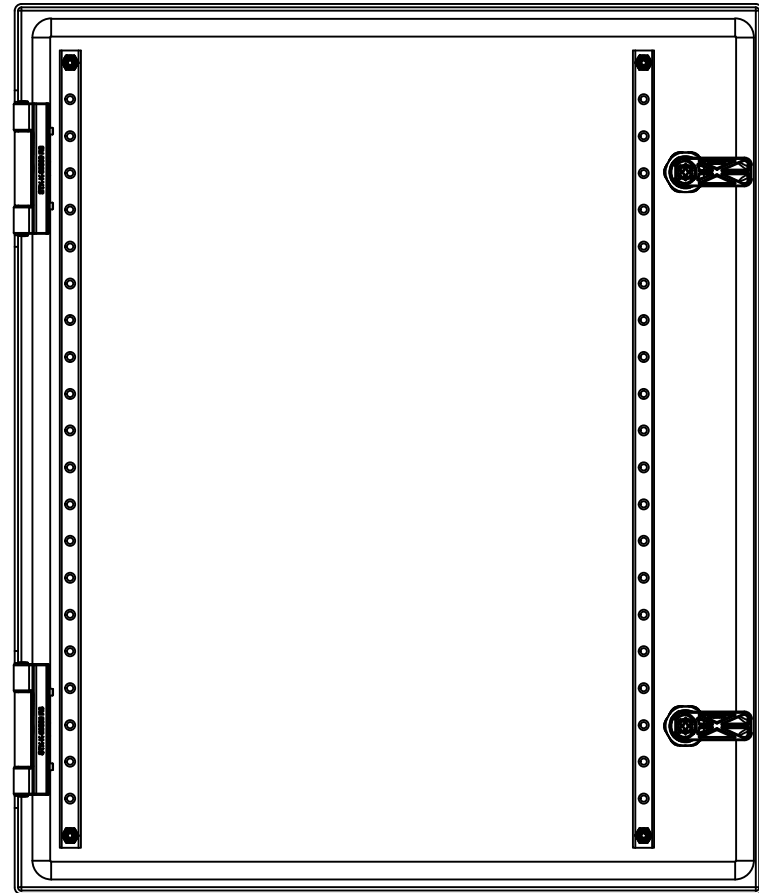

BACK

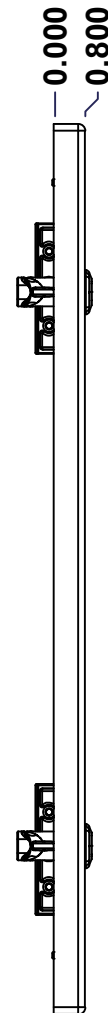

LEFT

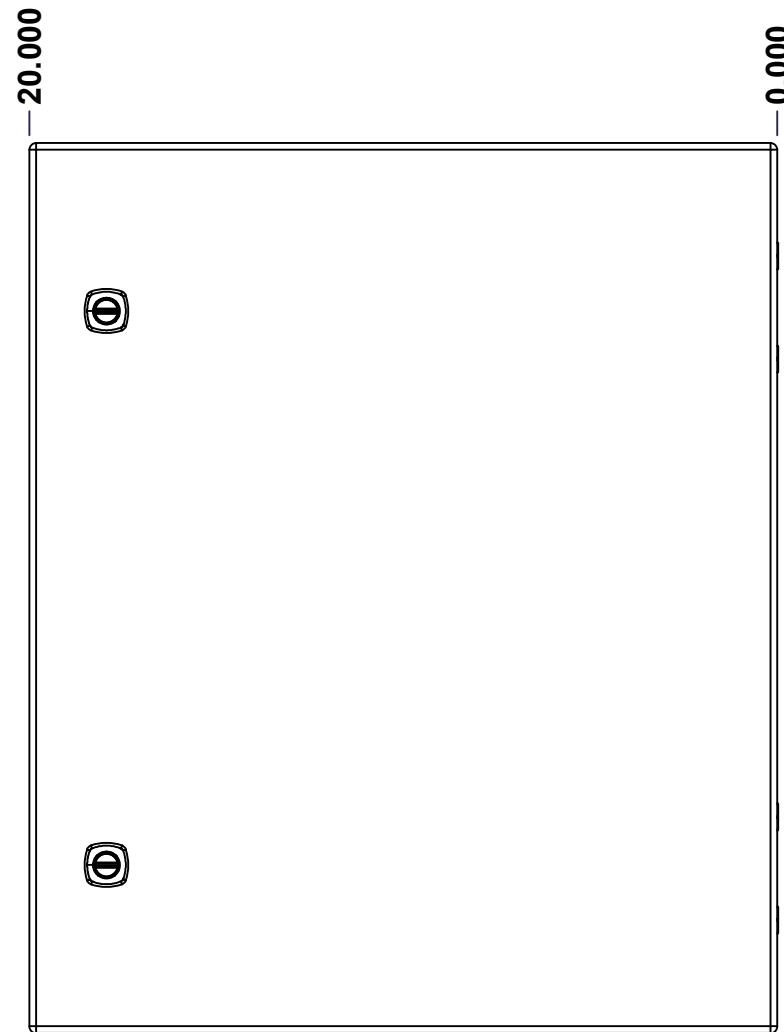

FRONT

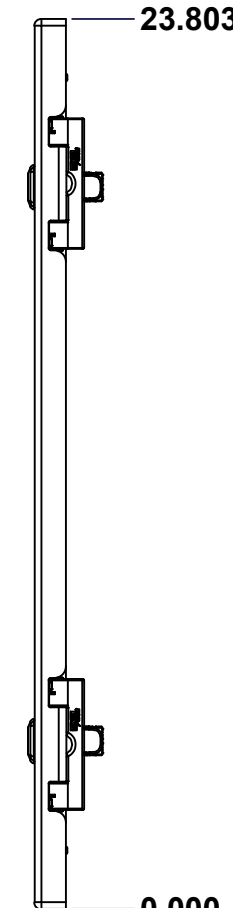

RIGHT

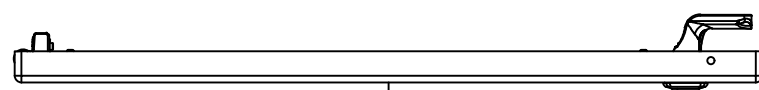

BOTTOM

No.	Revisions	Date	By/Par

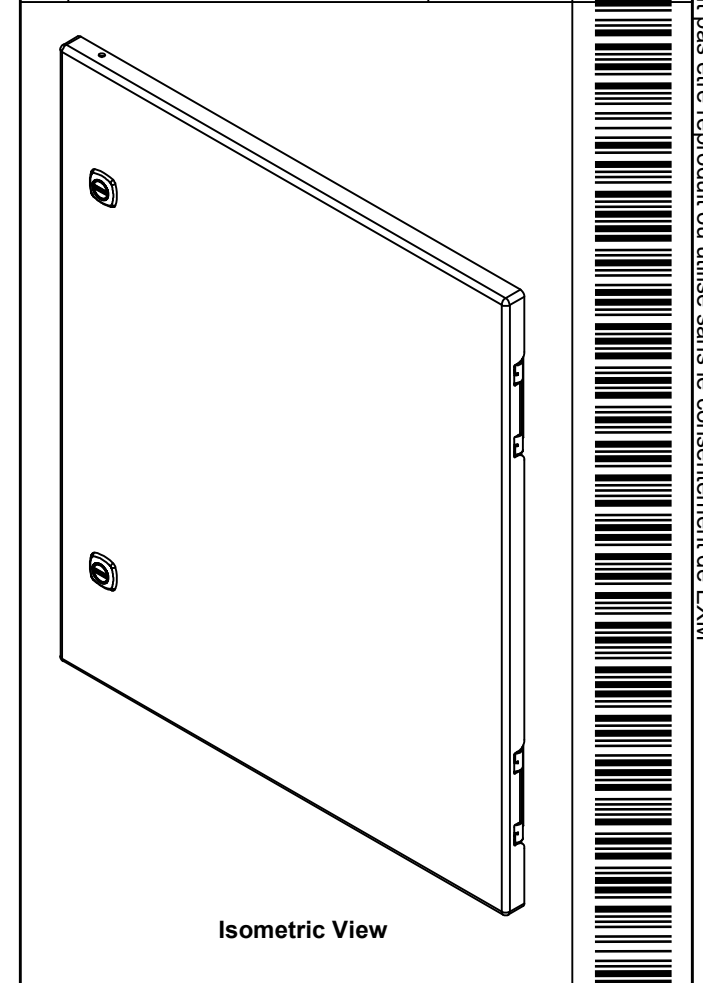

Isometric View

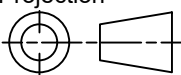

 Tél: (450) 979-4373 Fax: (450) 979-4626 <a href="http://www.exmweb.com">www.exmweb.com</a>		Flatness Aplatissement Max 3.0mm Projection 
Customer Client	Date	
Drawn By Dessiné Par	BoxCad: BoxCad	Date 23-Jan-26
Material Matière	12 Ga Cold Rolled A1008 CS Type B (2.5mm)	
Color Couleur	Asa-61 Grey	Finish Fini Smooth
Description		Detail Rev.
5412ESDDHD 24" x 42" Cover		
Part Number Numéro Pièce	Rev. 0	11 / 13

SEE BILL OF MATERIAL ON LAST PAGE

**5412ESDDHD244210RD**

This drawing is confidential and must not be reproduced or used without the consent of EXM

Ce dessin est confidentiel et ne doit pas être reproduit ou utilisé sans le consentement de EXM

**STANDARD FEATURES ARE NOT LISTED IN THIS HOLE TABLE**

**HOLE TABLE - FRONT VIEW (CUSTOM FEATURE ONLY)**

CUT-OUT	XDIM	YDIM	DESCRIPTION
1	1.486	1.567	STUD M6 x 18mm (Inside)
2	1.486	22.236	STUD M6 x 18mm (Inside)
3	16.819	22.236	STUD M6 x 18mm (Inside)
4	16.819	1.567	STUD M6 x 18mm (Inside)
-----			
5	17.938	4.496	LOCK 889 SCQ4-SL @ 180.0°
6	17.938	19.308	LOCK 889 SCQ4-SL @ 180.0°

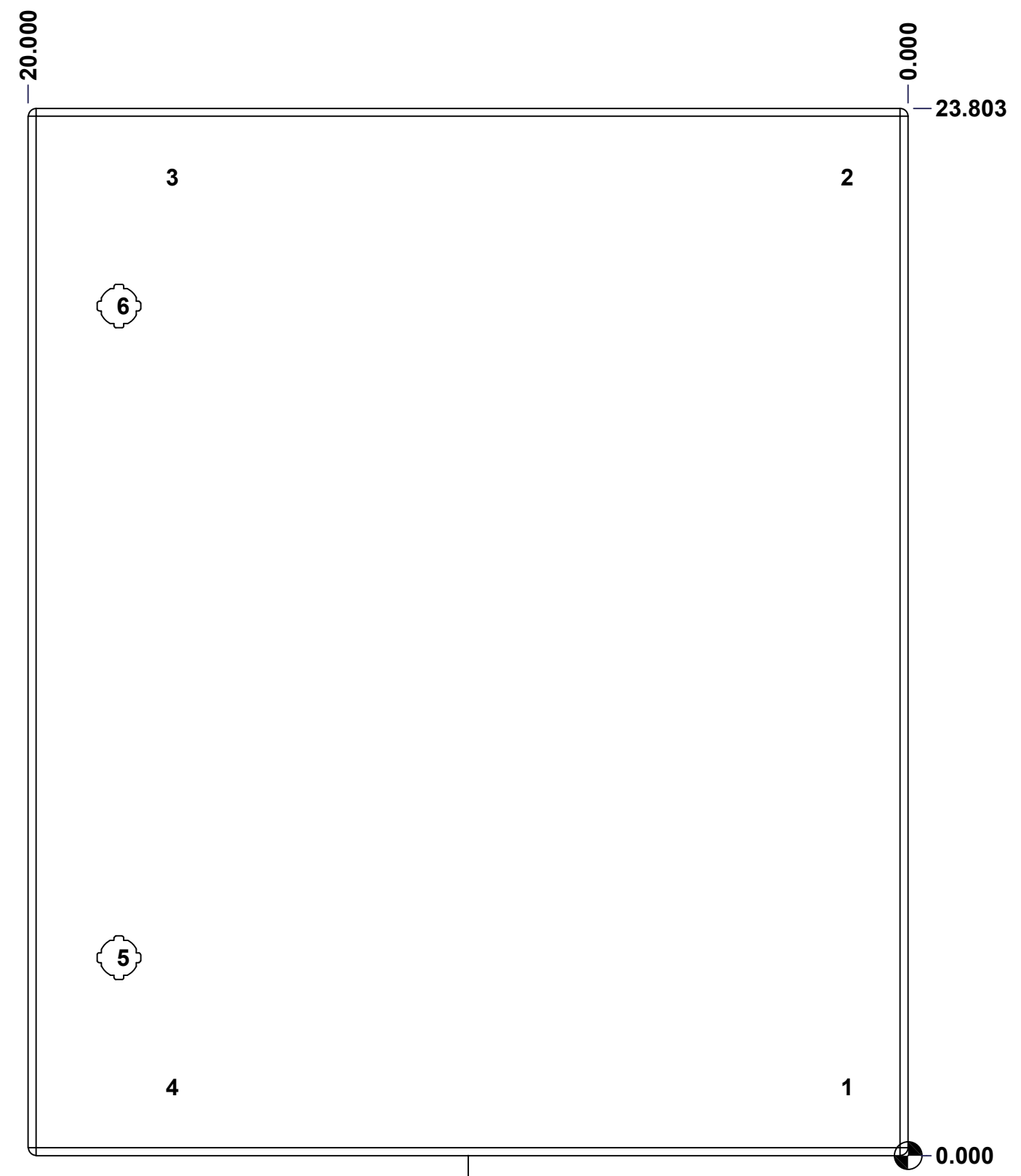

FRONT

	Description	Status
	5412ESDDHD 24" x 42" Cover	(NULL)
	Part Number Numéro Pièce	Rev.
	<b>5412ESDDHD244210RD</b>	<b>0</b>
		12
		13

This drawing is confidential and must not be reproduced or used without the consent of EXM

Ce dessin est confidentiel et ne doit pas être reproduit ou utilisé sans le consentement de EXM

No.	Revisions	Date	By/Par

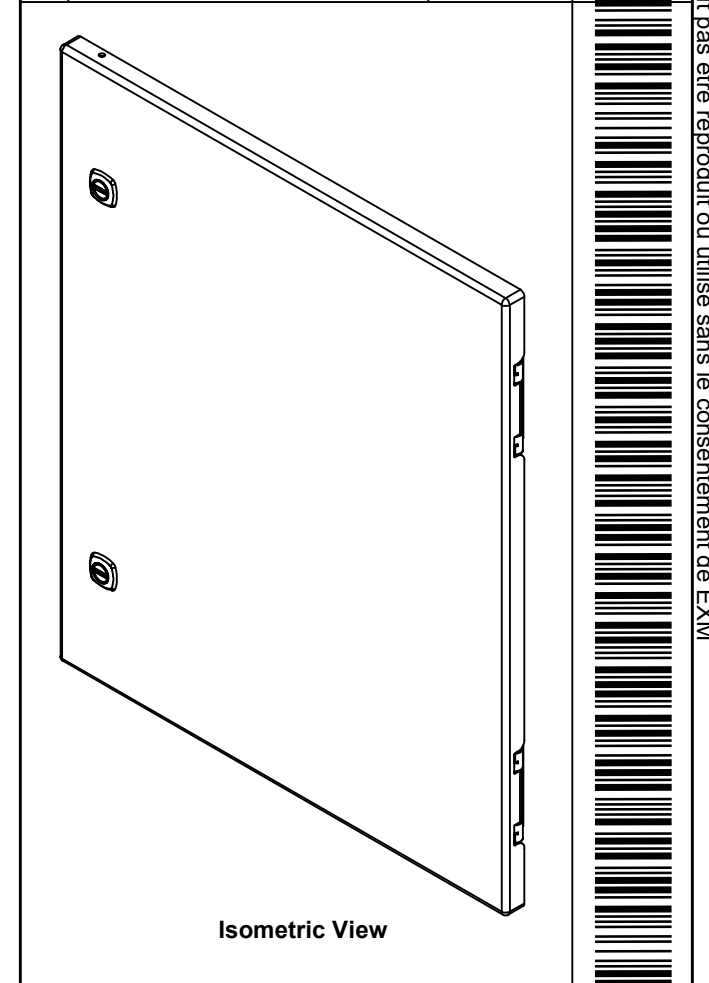

 Tél: (450) 979-4373  
 Fax: (450) 979-4626  
[www.exmweb.com](http://www.exmweb.com)

Flatness / Aplatissement: Max 3.0mm  
 Projection: 

2	STK-K-12580	0	9412 1/4 Turn Lock
1	STK-P-02400S	0	Powder Paint (Asa-61 Grey / Smooth)
4	STK-Q-07220	1	M6 Nylon Insert Lock Nut
2	STK-Q-46020-24	5	5412 ES Vertical Door Stiffener 24"
4	STK-Q-16055	1	M6 x 18mm Stud (No Paint Cap Required)
2	STK-K-09860	7	Cabinet Hinge with Captive Pins
1	5412ESDDHD244210RD-G	0	5412ESDDHD 24" x 20" Cover Gasket Part
1	5412ESDDHD244210RD-P	0	5412ESDDHD 24" x 42" Cover Part
QTY	Part Number	Rev	Description
Parts List			

Customer Client	Date
Drawn By / Dessiné Par: BoxCad: BoxCad	Date: 23-Jan-26
Material / Matière: 12 Ga Cold Rolled A1008 CS Type B (2.5mm)	
Color / Couleur: Asa-61 Grey	Finish / Fini: Smooth
Description: 5412ESDDHD 24" x 42" Cover	Detail Rev.:
Part Number / Numéro Pièce: <b>5412ESDDHD244210RD</b>	Rev. 0
	13
	13

This drawing is confidential and must not be reproduced or used without the consent of EXM

Ce dessin est confidentiel et ne doit pas être reproduit ou utilisé sans le consentement de EXM

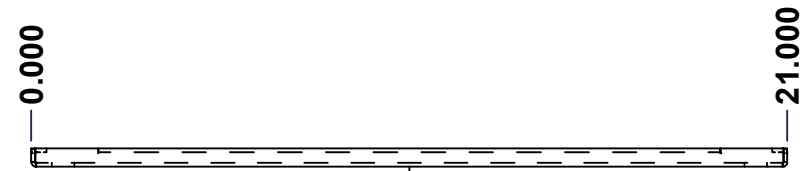

TOP

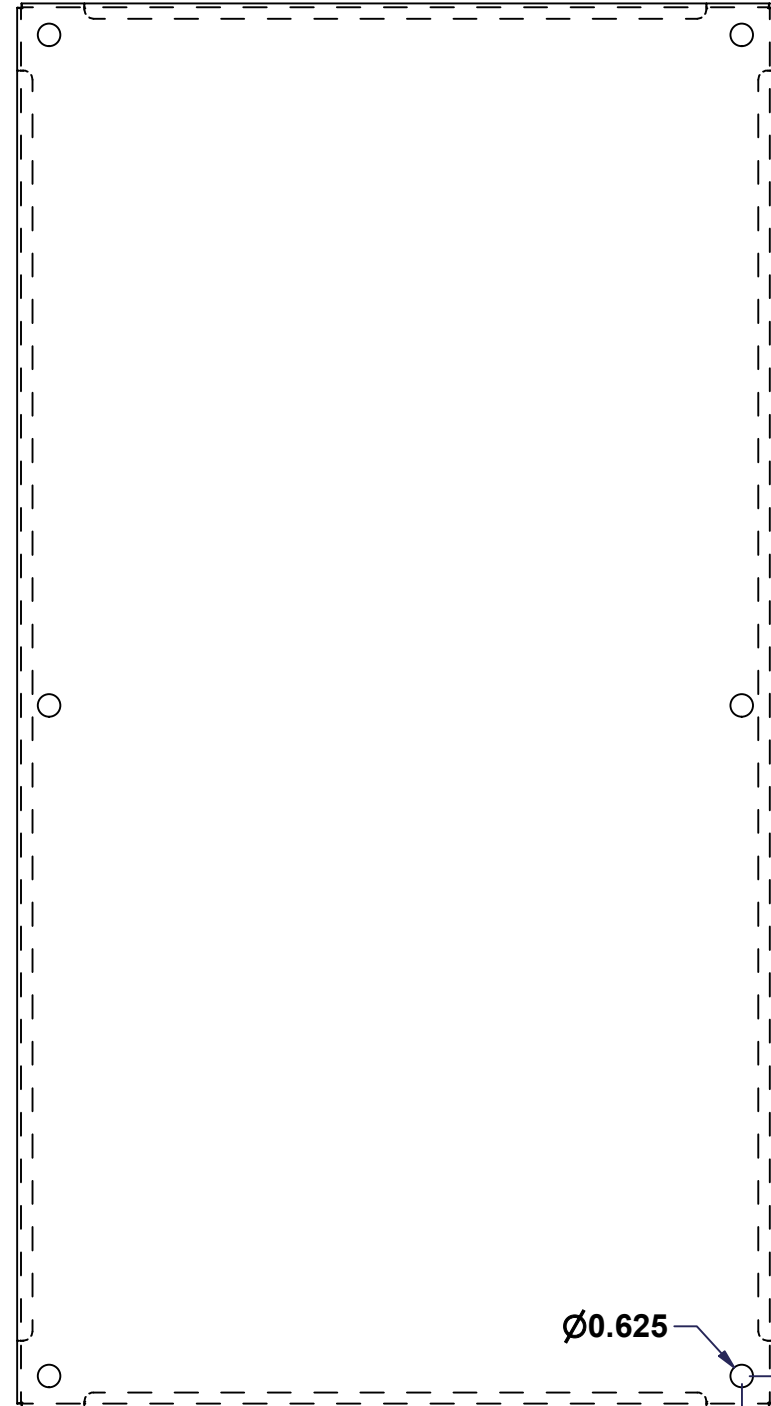

FRONT

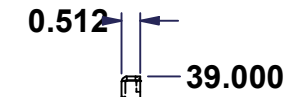

RIGHT

No.	Revisions	Date	By/Par

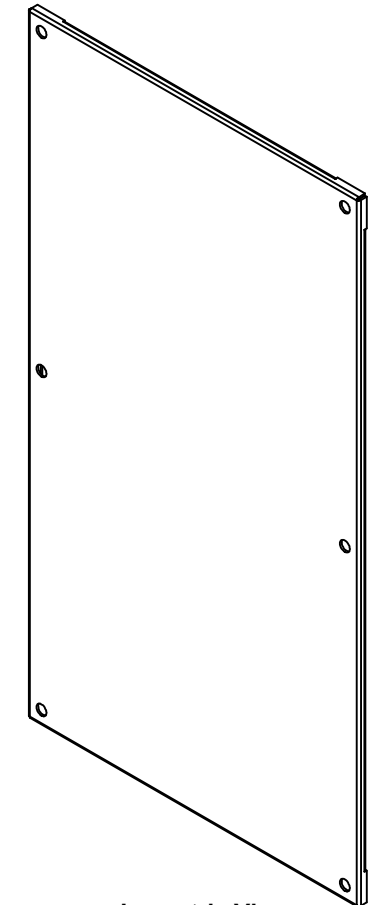

Isometric View

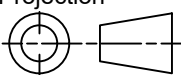

 Tél: (450) 979-4373 Fax: (450) 979-4626 <a href="http://www.exmweb.com">www.exmweb.com</a>	Flatness Aplatissement	Max 3.0mm
	Projection	
Customer Client	Date	
Drawn By Dessiné Par	BoxCad: nickz	Date 01/03/2017
Material Matière	12 Ga Galvanized (2.5mm)	
Color Couleur	See Part List	Finish Fini See Part List
Description	885SP 42" x 24" Inner Panel Part	
Part Number Numéro Pièce	Rev. 0	1

Qty	Part Number	Rev	Description	Material	Color	Finish
1	885SP4224G-P	0	885SP 42" x 24" Inner Panel Part	12 Ga Galvanized (2.5mm)	Unpainted	Galvanized

Parts List

**885SP4224G**