

This drawing is confidential and must not be reproduced or used without the consent of EXM

Ce dessin est confidentiel et ne doit pas être reproduit ou utilisé sans le consentement de EXM

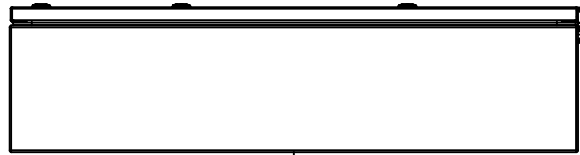

TOP

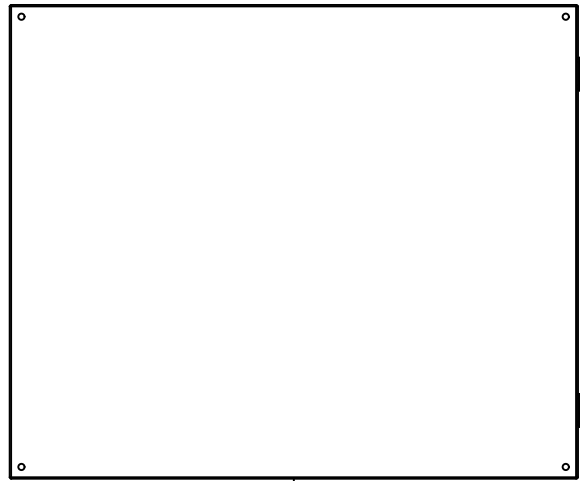

BACK

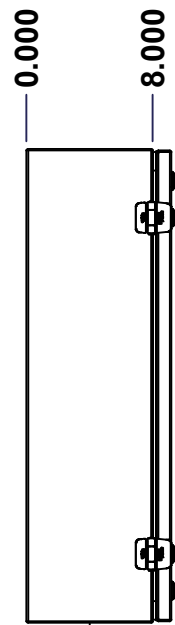

LEFT

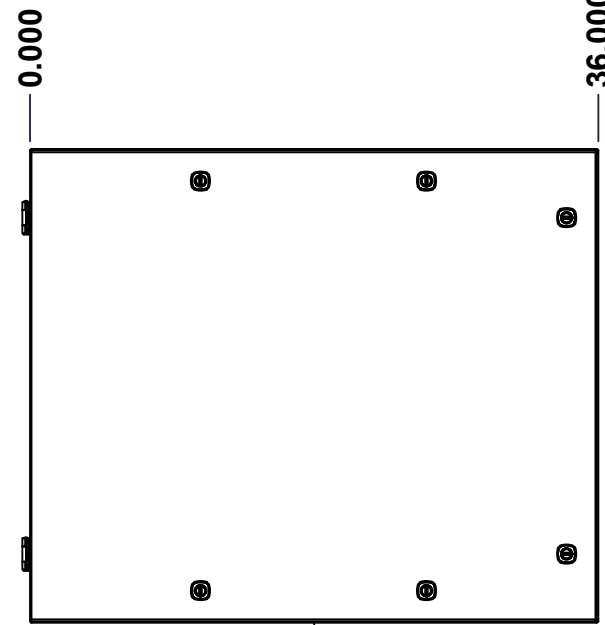

FRONT

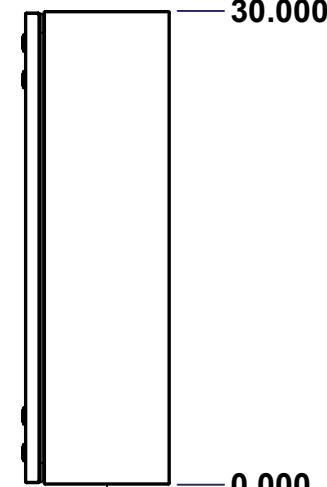

RIGHT

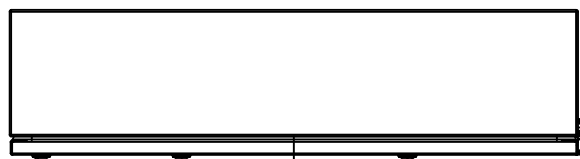

BOTTOM

| No. | Revisions | Date | By/Par |
|-----|-----------|------|--------|
|     |           |      |        |
|     |           |      |        |
|     |           |      |        |
|     |           |      |        |

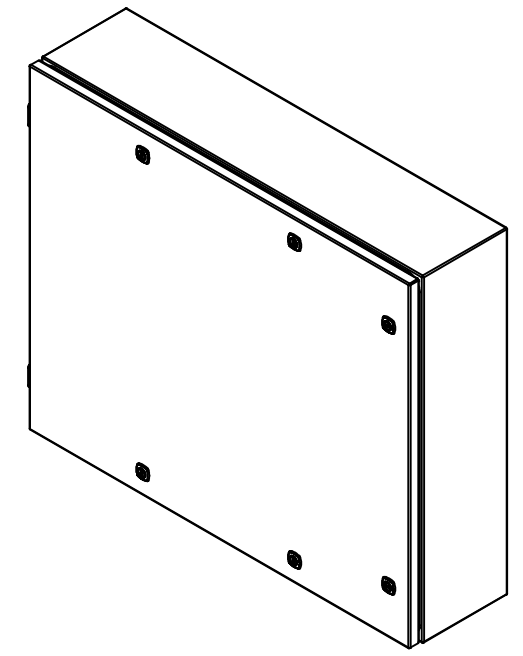

Isometric View



Tél: (450) 979-4373  
 Fax: (450) 979-4626  
[www.exmweb.com](http://www.exmweb.com)

Flatness  
Aplatissement  
Max 3.0mm  
Projection

Customer Client  
 Drawn By Dessiné Par BoxCad: BoxCad  
 Date 04-Dec-24

Material Matière 14 Ga Cold Rolled A1008 CS Type B (1.7mm)

Color Couleur Asa-61 Grey  
 Finish Fini Smooth

Description 5412ESDG 30" x 36" x 8" Assembly  
 Detail Rev.

Part Number Numéro Pièce 5412ESDG303608  
 Rev. 0

SEE BILL OF MATERIAL ON LAST PAGE

1  
9

This drawing is confidential and must not be reproduced or used without the consent of EXM

Ce dessin est confidentiel et ne doit pas être reproduit ou utilisé sans le consentement de EXM

| NOTE |  |
|------|--|
| ITEM | DESCRIPTION                                |
| 1    | NEMA 4, 12 Enclosure (IP66)                |
| 2    | C/W Standard ground studs on box and cover |
| 3    | W/O Standard door stiffener                |
| 4    | C/W Standard inner panel (Included)        |
| 5    | C/W Standard inner panel mounting studs    |

| No. | Revisions | Date | By/Par |
|-----|-----------|------|--------|
|     |           |      |        |
|     |           |      |        |
|     |           |      |        |
|     |           |      |        |
|     |           |      |        |
|     |           |      |        |

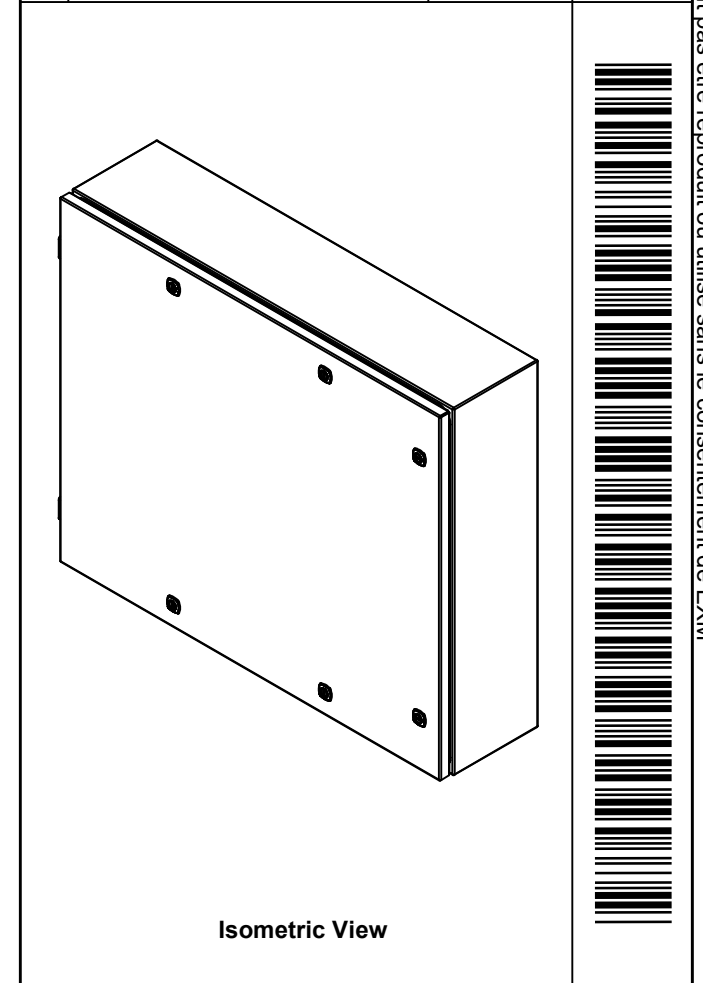



Tél: (450) 979-4373  
Fax: (450) 979-4626  
[www.exmweb.com](http://www.exmweb.com)

Flatness  
Aplatissement  
Max 3.0mm

Projection

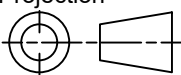

|   |                 |
|---|-----------------|
| Customer Client   | Date            |
| Drawn By / Dessiné Par: BoxCad: BoxCad                        | Date: 04-Dec-24 |
| Material / Matière: 14 Ga Cold Rolled A1008 CS Type B (1.7mm) |                 |

| PACKING               |     |  |
|-----------------------|-----|--|
| ITEM                  | QTY | DESCRIPTION                                |
| Cardboard sleeve      | 2   | Top and Bottom                             |
| Cardboard strip       | 2   | Between back of enclosure and inner panel  |
| Plastic bag           | 1   | To protect cover surface and inside gasket |
| Plastic strap - Black | 2   | To Squeeze the 2 cardboard sleeve together |
| Packaging label       | 1   | White label with product number            |

|            |                 |     |                                   |
|------------|-----------------|-----|-----------------------------------|
| 1          | STK-K-01800     | 5   | 5412 ES Accessory Kit             |
| 1          | 885SP3630G      | 0   | 885SP 36" x 30" Inner Panel Part  |
| 3          | STK-K-01320     | 0   | 5412 ES Inner Panel Accessory Kit |
| 2          | STK-Q-07220     | 1   | M6 Nylon Insert Lock Nut          |
| 2          | STK-Q-10252     | 0   | M6 Stainless Steel Sealing Washer |
| 1          | 5412ESDG303608C | 0   | 5412ESDG 30" x 36" Cover          |
| 1          | 5412ESDG303608B | 0   | 5412ESDG 30" x 36" x 8" Body      |
| Qty        | Part Number     | Rev | Description                       |
| Parts List |                 |     |                                   |

|   |                        |
|---|------------------------|
| Color / Couleur: Asa-61 Grey                      | Finish / Fini: Smooth  |
| Description: 5412ESDG 30" x 36" x 8" Assembly     |                        |
| Part Number / Numéro Pièce: <b>5412ESDG303608</b> | Rev. / Révis: <b>0</b> |
| 2 / 9   |                        |

This drawing is confidential and must not be reproduced or used without the consent of EXM

Ce dessin est confidentiel et ne doit pas être reproduit ou utilisé sans le consentement de EXM



TOP

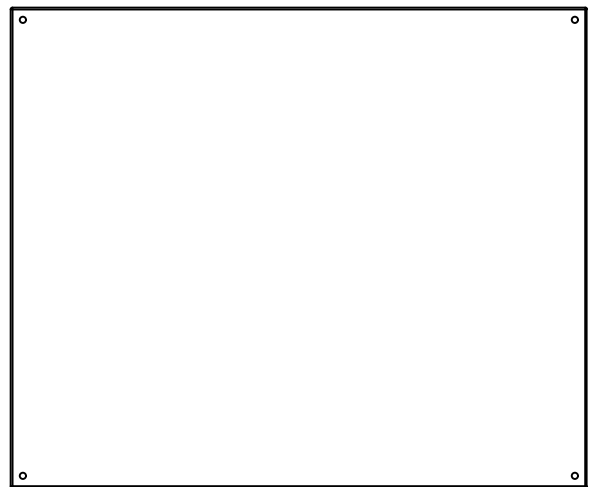

BACK

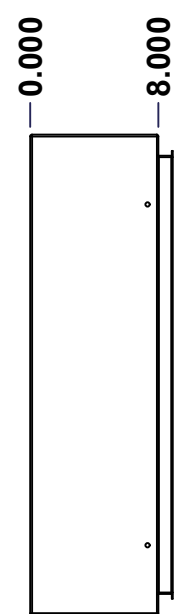

LEFT

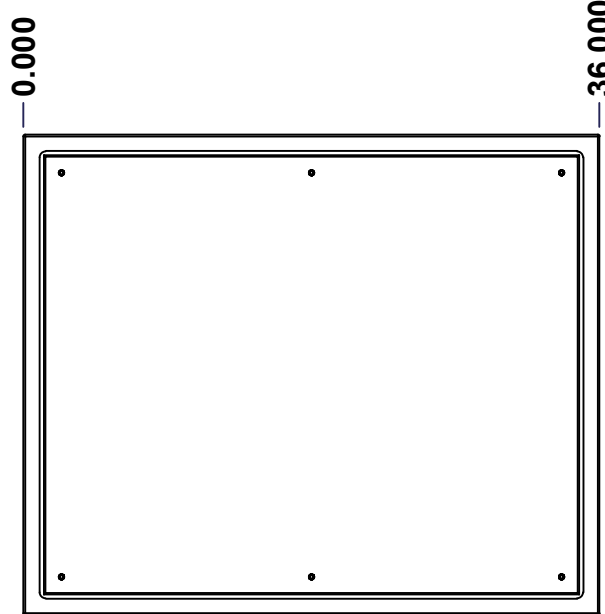

FRONT

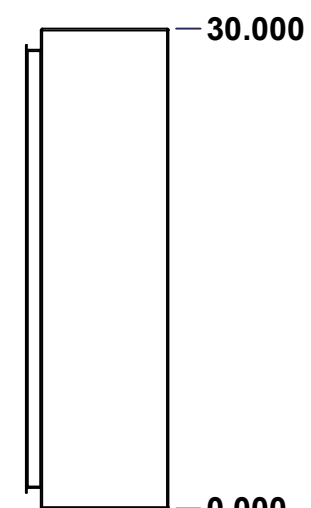

RIGHT

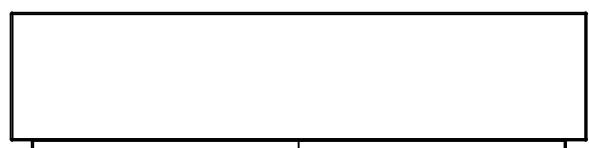

BOTTOM

| No. | Revisions | Date | By/Par |
|-----|-----------|------|--------|
|     |           |      |        |
|     |           |      |        |
|     |           |      |        |
|     |           |      |        |

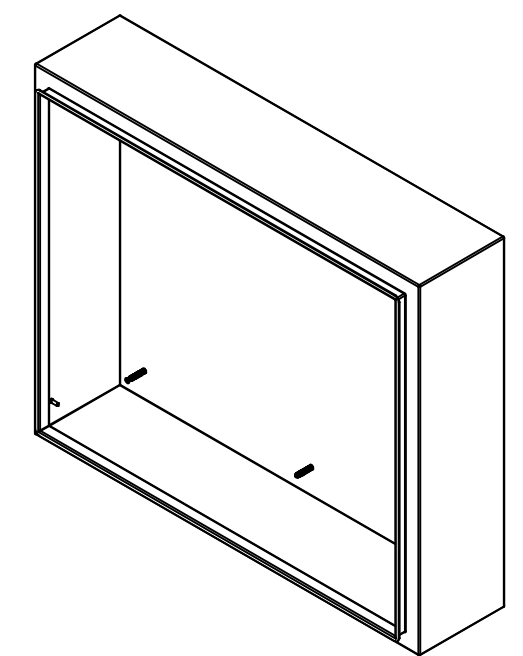

Isometric View



Tél: (450) 979-4373  
 Fax: (450) 979-4626  
[www.exmweb.com](http://www.exmweb.com)

Flatness  
Aplatissement  
Max 3.0mm  
Projection

|   |                       |
|---|-----------------------|
| Customer Client   | Date                  |
| Drawn By / Dessiné Par: BoxCad: BoxCad                        | Date: 04-Dec-24       |
| Material / Matière: 14 Ga Cold Rolled A1008 CS Type B (1.7mm) |                       |
| Color / Couleur: Asa-61 Grey                                  | Finish / Fini: Smooth |
| Description: 5412ESDG 30" x 36" x 8" Body                     |                       |
| Detail Rev.   |                       |
| Part Number / Numéro Pièce: 5412ESDG303608B                   | Rev. 3                |
| SEE BILL OF MATERIAL ON LAST PAGE                             | 0                     |

SEE BILL OF MATERIAL ON LAST PAGE

This drawing is confidential and must not be reproduced or used without the consent of EXM

Ce dessin est confidentiel et ne doit pas être reproduit ou utilisé sans le consentement de EXM

| <b>STANDARD FEATURES ARE NOT LISTED IN THIS HOLE TABLE</b> |       |       |                             |
|--|-------|-------|-----------------------------|
| <b>HOLE TABLE - LEFT VIEW (CUSTOM FEATURE ONLY)</b>        |       |       |                             |
| CUT-OUT  | XDIM  | YDIM  | DESCRIPTION                 |
| 1  | 6.500 | 2.000 | GND STUD M6 x 16mm (Inside) |

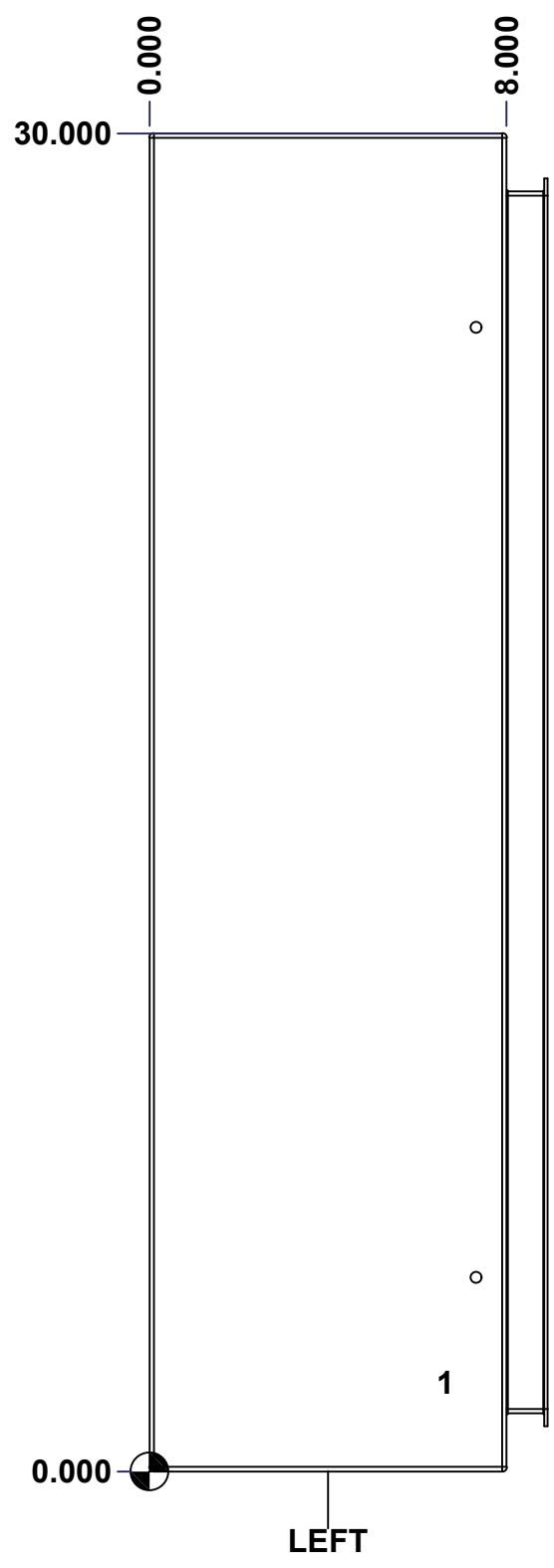

|  |                              |          |        |
|--|------------------------------|----------|--------|
|  | Description                  | Status   |        |
|  | 5412ESDG 30" x 36" x 8" Body | (NULL)   |        |
|  | Part Number<br>Numéro Pièce  | Rev.     |        |
|  | <b>5412ESDG303608B</b>       | <b>0</b> | 4<br>9 |

This drawing is confidential and must not be reproduced or used without the consent of EXM

Ce dessin est confidentiel et ne doit pas être reproduit ou utilisé sans le consentement de EXM

**STANDARD FEATURES ARE NOT LISTED IN THIS HOLE TABLE**

**HOLE TABLE - BACK VIEW (CUSTOM FEATURE ONLY)**

| CUT-OUT | XDIM   | YDIM   | DESCRIPTION                |
|---------|--------|--------|----------------------------|
| 1       | 2.375  | 2.375  | IP STUD M8 x 35mm (Inside) |
| 2       | 2.375  | 27.625 | IP STUD M8 x 35mm (Inside) |
| 3       | 33.625 | 27.625 | IP STUD M8 x 35mm (Inside) |
| 4       | 33.625 | 2.375  | IP STUD M8 x 35mm (Inside) |
| 5       | 18.000 | 2.375  | IP STUD M8 x 35mm (Inside) |
| 6       | 18.000 | 27.625 | IP STUD M8 x 35mm (Inside) |
| -----   |        |        |                            |
| 7       | 0.750  | 0.750  | RND Ø0.390                 |
| 8       | 0.750  | 29.250 | RND Ø0.390                 |
| 9       | 35.250 | 29.250 | RND Ø0.390                 |
| 10      | 35.250 | 0.750  | RND Ø0.390                 |

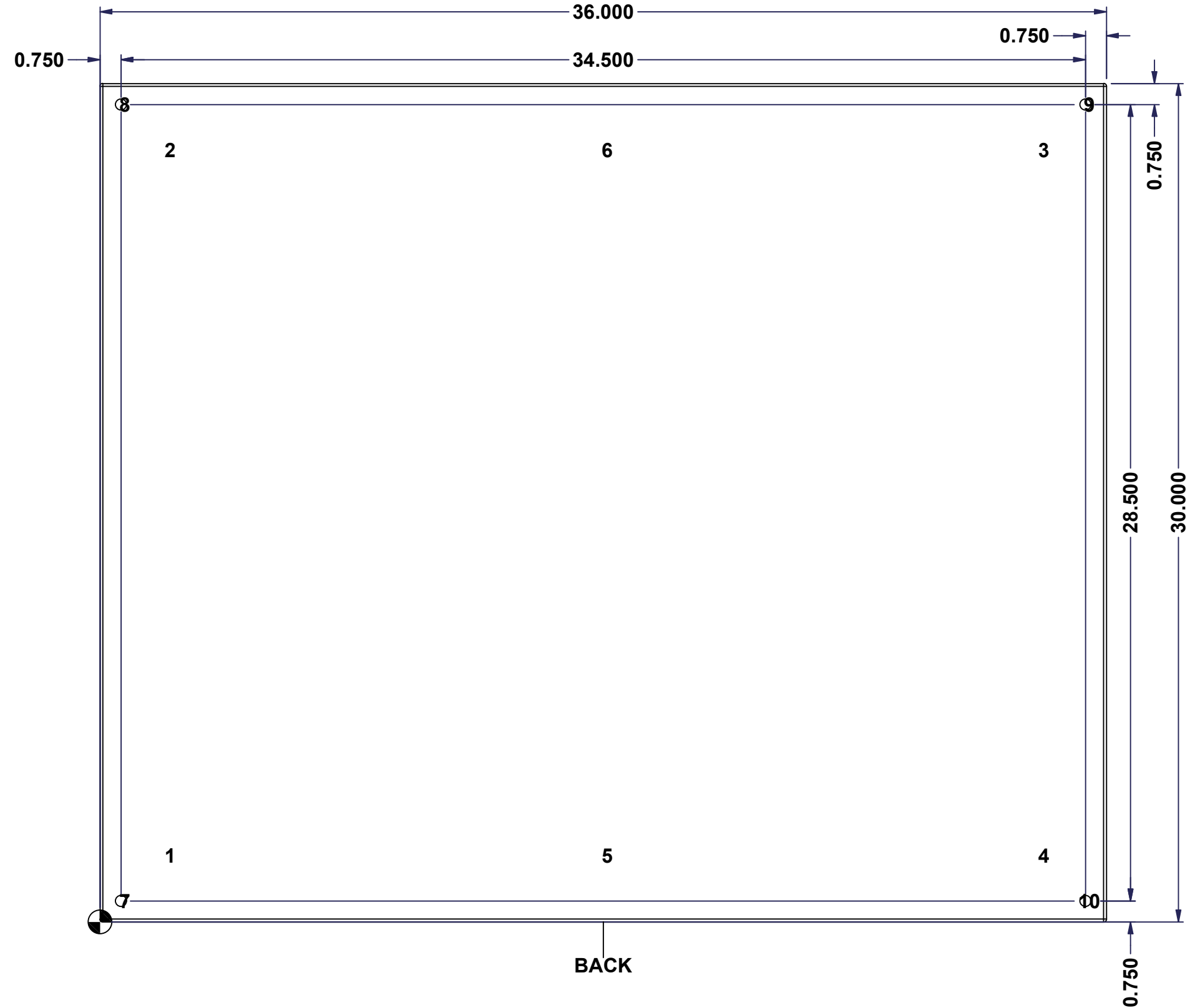

BACK

|  |                              |          |   |
|--|------------------------------|----------|---|
|  | Description                  | Status   |   |
|  | 5412ESDG 30" x 36" x 8" Body | (NULL)   |   |
|  | Part Number<br>Numéro Pièce  | Rev.     | 5 |
|  | <b>5412ESDG303608B</b>       | <b>0</b> | 9 |

This drawing is confidential and must not be reproduced or used without the consent of EXM

Ce dessin est confidentiel et ne doit pas être reproduit ou utilisé sans le consentement de EXM

| No. | Revisions | Date | By/Par |
|-----|-----------|------|--------|
|     |           |      |        |
|     |           |      |        |
|     |           |      |        |
|     |           |      |        |
|     |           |      |        |

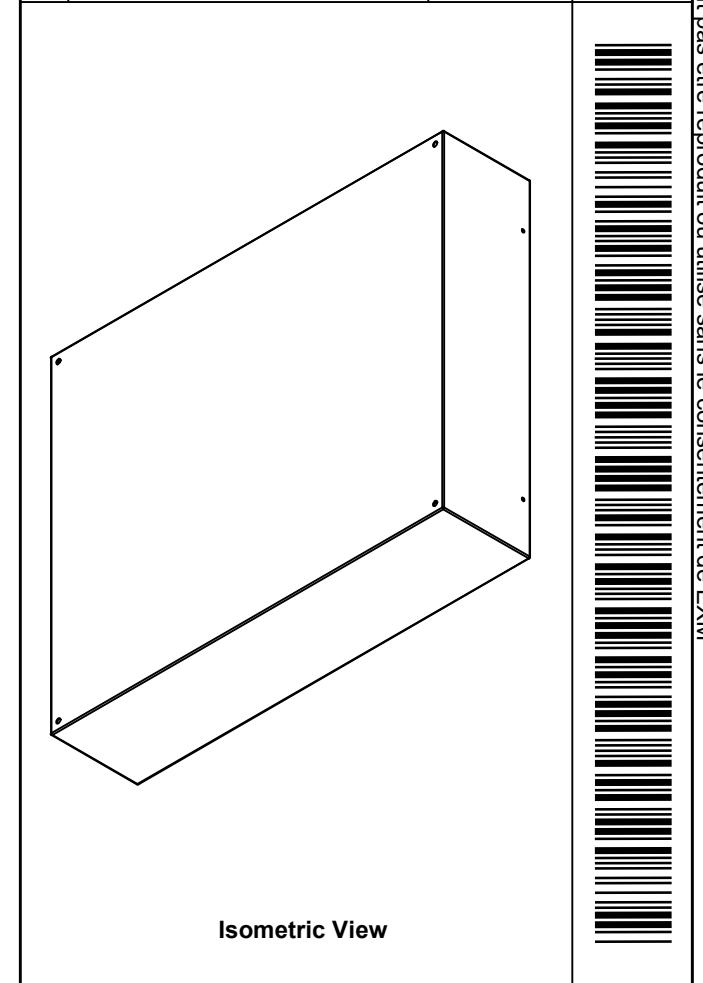

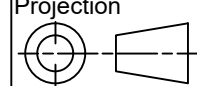
|  |                       |   |
|--|-----------------------|---|
|  Tél: (450) 979-4373<br>Fax: (450) 979-4626<br><a href="http://www.exmweb.com">www.exmweb.com</a> |                       | Flatness<br>Aplatissement<br>Max 3.0mm<br>Projection<br> |
| Customer Client  | Date                  |   |
| Drawn By / Dessiné Par: BoxCad: BoxCad   | Date: 04-Dec-24       |   |
| Material / Matière: 14 Ga Cold Rolled A1008 CS Type B (1.7mm)  |                       |   |
| Color / Couleur: Asa-61 Grey   | Finish / Fini: Smooth |   |
| Description: 5412ESDG 30" x 36" x 8" Body  |                       | Detail Rev.   |
| Part Number / Numéro Pièce: <b>5412ESDG303608B</b>   | Rev.:                 | 6   |
|  |                       | 9   |

| Qty        | Part Number       | Rev | Description                         |
|------------|-------------------|-----|-------------------------------------|
| 1          | STK-Q-16080       | 0   | Ground Stud M6 x 16mm Steel         |
| 1          | STK-P-02400S      | 0   | Powder Paint (Asa-61 Grey / Smooth) |
| 6          | STK-Q-16005       | 0   | Stud M8 x 35mm Steel                |
| 1          | 5412ESDG303608B-P | 0   | 5412ESDG 30" x 36" x 8" Body Part   |
| Parts List |                   |     |                                     |

This drawing is confidential and must not be reproduced or used without the consent of EXM

Ce dessin est confidentiel et ne doit pas être reproduit ou utilisé sans le consentement de EXM

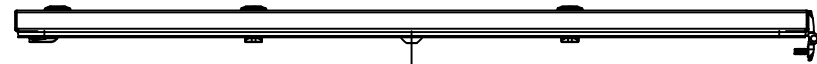

TOP

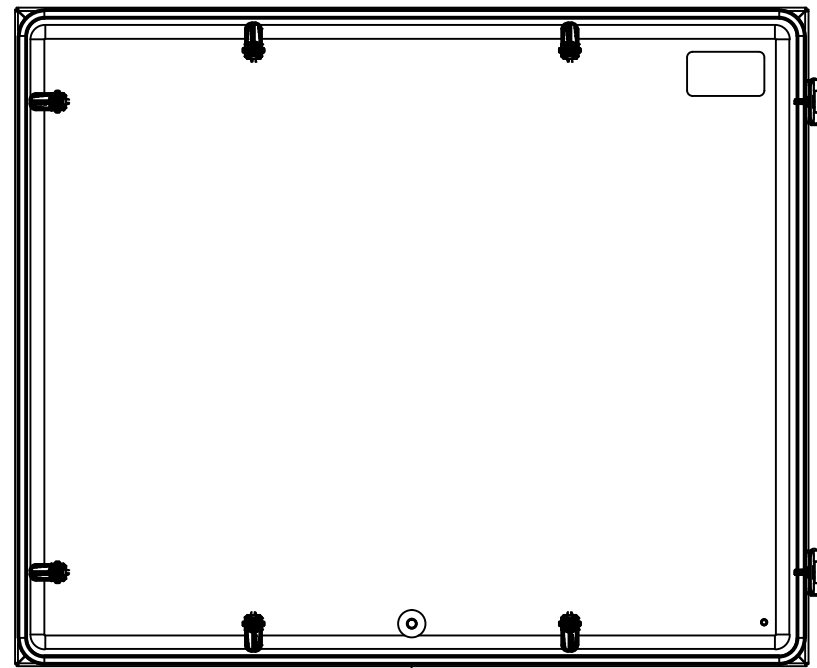

BACK

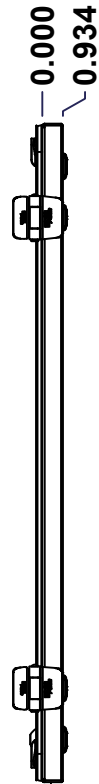

LEFT

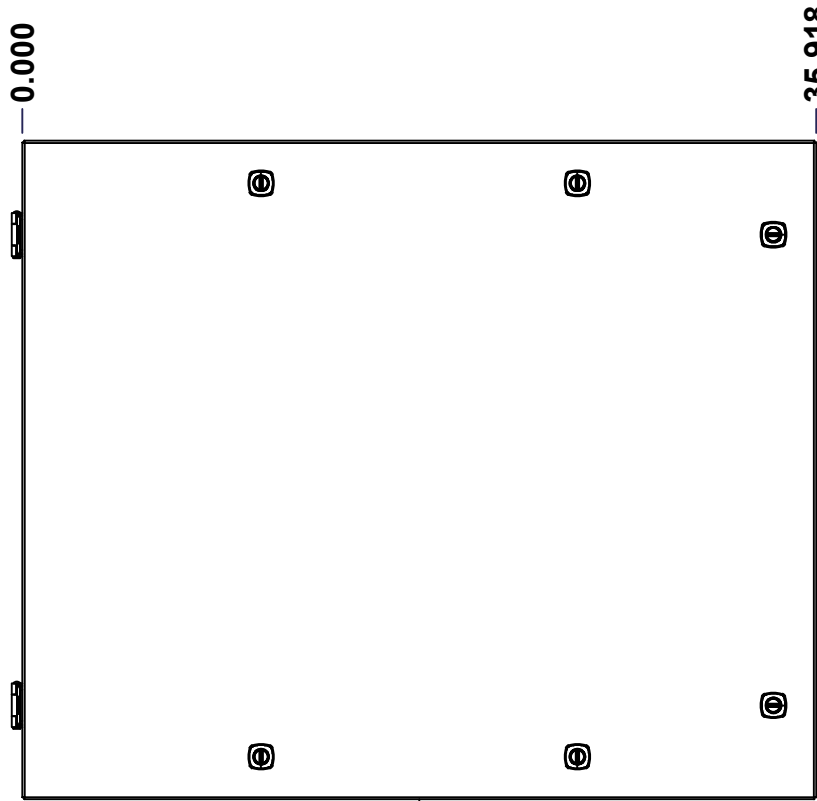

FRONT

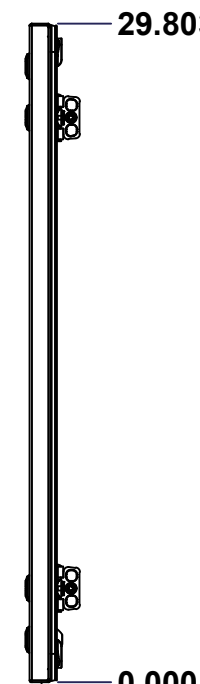

RIGHT



BOTTOM

| No. | Revisions | Date | By/Par |
|-----|-----------|------|--------|
|     |           |      |        |
|     |           |      |        |
|     |           |      |        |
|     |           |      |        |

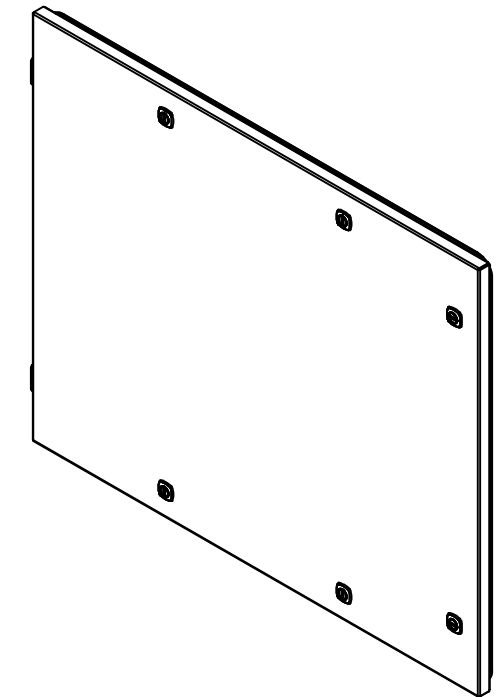

Isometric View



Tél: (450) 979-4373  
 Fax: (450) 979-4626  
[www.exmweb.com](http://www.exmweb.com)

Flatness  
Aplatissement

Max 3.0mm

Projection

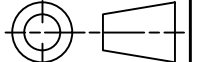

|   |                 |
|---|-----------------|
| Customer Client   | Date            |
| Drawn By / Dessiné Par: BoxCad: BoxCad                        | Date: 04-Dec-24 |
| Material / Matière: 14 Ga Cold Rolled A1008 CS Type B (1.7mm) |                 |

|                              |                       |
|------------------------------|-----------------------|
| Color / Couleur: Asa-61 Grey | Finish / Fini: Smooth |
|------------------------------|-----------------------|

|                                       |             |
|---------------------------------------|-------------|
| Description: 5412ESDG 30" x 36" Cover | Detail Rev. |
|---------------------------------------|-------------|

|   |        |       |
|---|--------|-------|
| Part Number / Numéro Pièce: 5412ESDG303608C | Rev. 0 | 7 / 9 |
|---|--------|-------|

SEE BILL OF MATERIAL ON LAST PAGE

This drawing is confidential and must not be reproduced or used without the consent of EXM

Ce dessin est confidentiel et ne doit pas être reproduit ou utilisé sans le consentement de EXM

**STANDARD FEATURES ARE NOT LISTED IN THIS HOLE TABLE**

**HOLE TABLE - FRONT VIEW (CUSTOM FEATURE ONLY)**

| CUT-OUT | XDIM   | YDIM   | DESCRIPTION                 |
|---------|--------|--------|-----------------------------|
| 1       | 17.959 | 1.435  | STUD M6 x 18mm (Inside)     |
| -----   |        |        |                             |
| 2       | 10.800 | 27.879 | LOCK 880 SCQ4-SL @ 90.0°    |
| 3       | 2.000  | 2.000  | GND STUD M6 x 16mm (Inside) |
| 4       | 10.800 | 1.924  | LOCK 880 SCQ4-SL @ 270.0°   |
| 5       | 25.118 | 1.924  | LOCK 880 SCQ4-SL @ 270.0°   |
| 6       | 25.118 | 27.879 | LOCK 880 SCQ4-SL @ 90.0°    |
| 7       | 33.994 | 25.553 | LOCK 880 SCQ4-SL @ 0.0°     |
| 8       | 3.750  | 26.803 | LABEL_EXM (Inside)          |
| 9       | 33.994 | 4.250  | LOCK 880 SCQ4-SL @ 0.0°     |

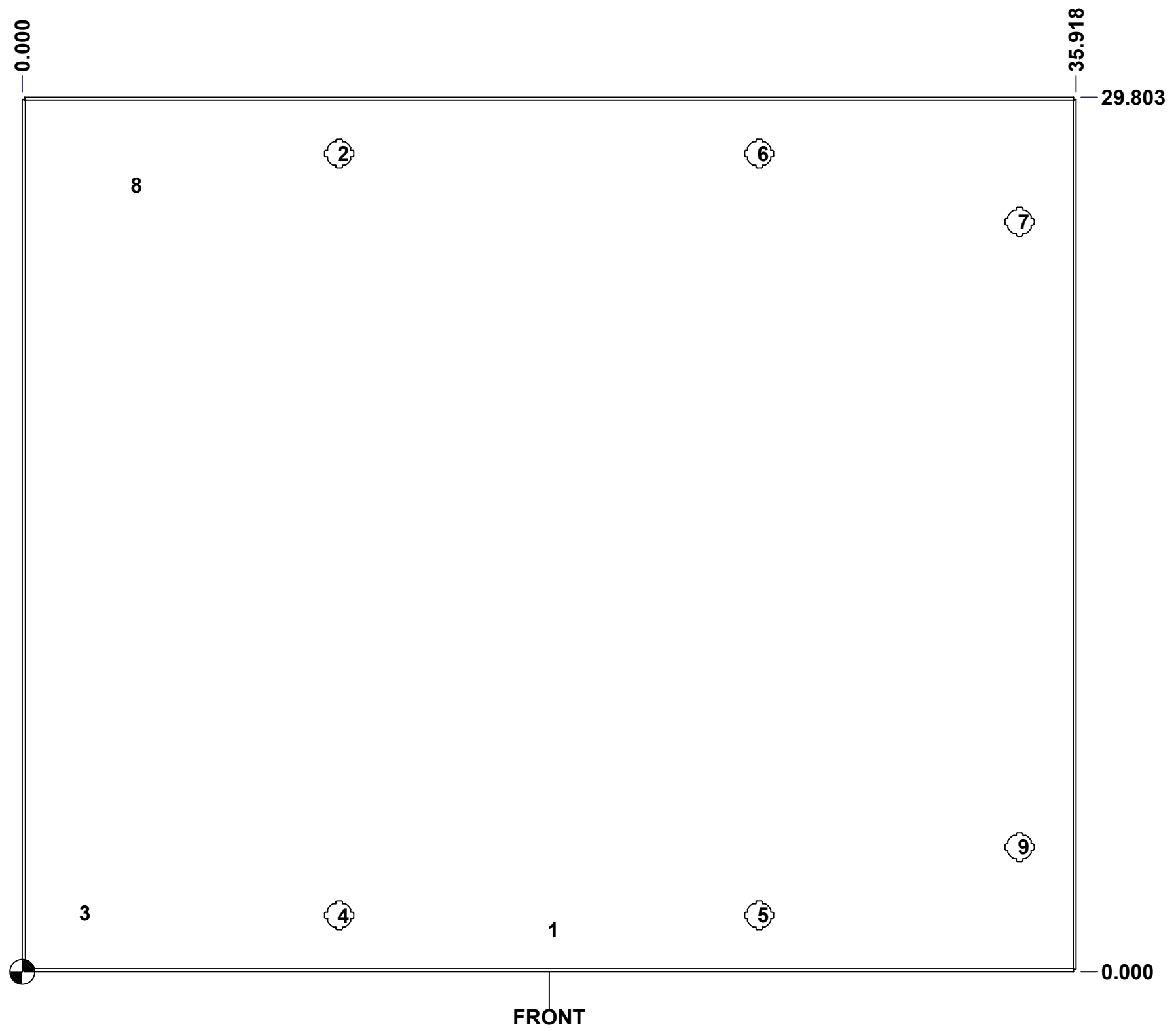

|  |                             |                  |
|--|-----------------------------|------------------|
|  | Description                 | Status           |
|  | 5412ESDG 30" x 36" Cover    | (NULL)           |
|  | Part Number<br>Numéro Pièce | Rev.             |
|  | <b>5412ESDG303608C</b>      | <b>0</b> / 8 / 9 |

This drawing is confidential and must not be reproduced or used without the consent of EXM

Ce dessin est confidentiel et ne doit pas être reproduit ou utilisé sans le consentement de EXM

| No. | Revisions | Date | By/Par |
|-----|-----------|------|--------|
|     |           |      |        |
|     |           |      |        |
|     |           |      |        |
|     |           |      |        |
|     |           |      |        |

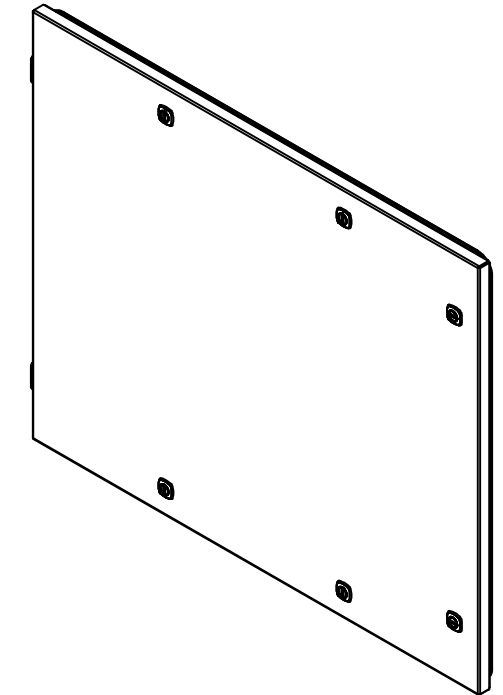

Isometric View

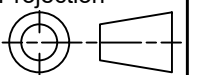

| 1          | STK-S-00100       | 0   | 3.5" x 2" Silver Milar Flexcon Sticker |
|------------|-------------------|-----|--|
| 1          | STK-Q-16080       | 0   | Ground Stud M6 x 16mm Steel            |
| 6          | STK-K-12500       | 19  | 5412 ES 1/4 Turn Lock                  |
| 1          | STK-P-02400S      | 0   | Powder Paint (Asa-61 Grey / Smooth)    |
| 1          | STK-Q-46515       | 3   | 5412 ES Door Support with Brass Insert |
| 1          | STK-Q-16055       | 1   | M6 x 18mm Stud (No Paint Cap Required) |
| 2          | STK-Q-07220       | 1   | M6 Nylon Insert Lock Nut               |
| 2          | STK-Q-10252       | 0   | M6 Stainless Steel Sealing Washer      |
| 2          | STK-A-02360       | 2   | External Hinge for Double Gasket       |
| 1          | 5412ESDG303608G2  | 0   | 5412ESDG 30" x 36" Cover Gasket        |
| 1          | 5412ESDG303608G   | 0   | 5412ESDG 30" x 36" Cover Gasket        |
| 1          | 5412ESDG303608C-P | 0   | 5412ESDG 30" x 36" Cover Part          |
| QTY        | Part Number       | Rev | Description                            |
| Parts List |                   |     |  |

|  |   |   |
|--|---|---|
|  Tél: (450) 979-4373<br>Fax: (450) 979-4626<br><a href="http://www.exmweb.com">www.exmweb.com</a> | Flatness<br>Aplatissement                 | Max 3.0mm   |
|  | Projection                                |  |
| Customer<br>Client   | Date                                      |   |
| Drawn By<br>Dessiné Par  | BoxCad: BoxCad                            | Date 04-Dec-24  |
| Material<br>Matière  | 14 Ga Cold Rolled A1008 CS Type B (1.7mm) |   |
| Color<br>Couleur   | Asa-61 Grey                               | Finish<br>Fini Smooth   |
| Description  | Detail Rev.                               |   |
| 5412ESDG 30" x 36" Cover   |   |   |
| Part Number<br>Numéro Pièce  | Rev.                                      | 9   |
| <b>5412ESDG303608C</b>   | <b>0</b>                                  | 9   |

This drawing is confidential and must not be reproduced or used without the consent of EXM

Ce dessin est confidentiel et ne doit pas être reproduit ou utilisé sans le consentement de EXM

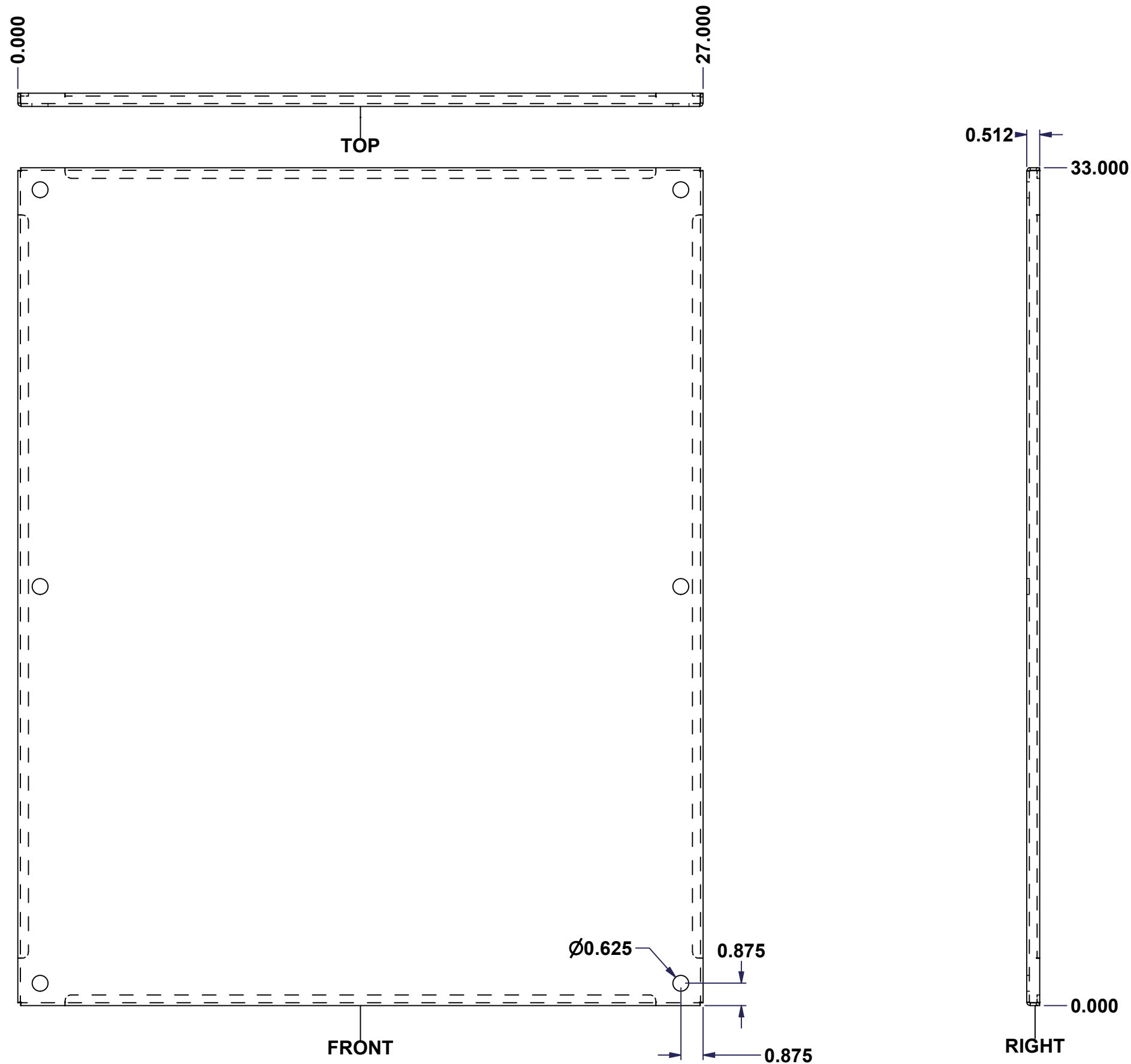

| No. | Revisions | Date | By/Par |
|-----|-----------|------|--------|
|     |           |      |        |
|     |           |      |        |
|     |           |      |        |
|     |           |      |        |
|     |           |      |        |

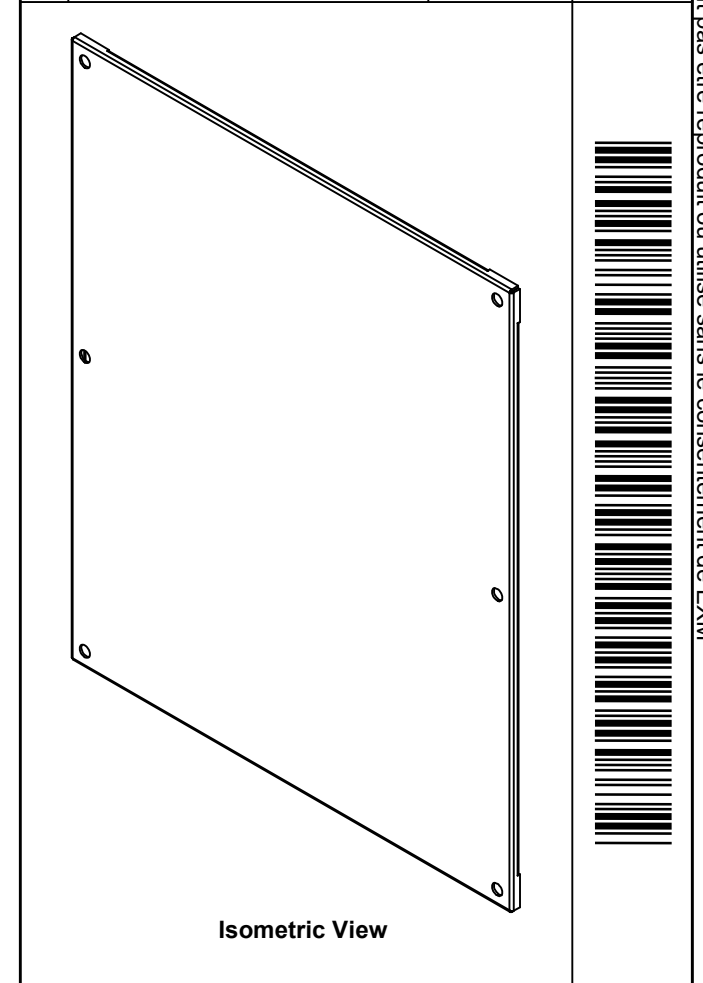

|  |                          |                              |
|--|--------------------------|------------------------------|
| Tél: (450) 979-4373<br>Fax: (450) 979-4626<br><a href="http://www.exmweb.com">www.exmweb.com</a> |                          | Flatness<br>Aplatissement    |
|  |                          | Max 3.0mm                    |
| Projection   |                          | Date                         |
| Customer<br>Client   | Date                     | Date 01/03/2017              |
| Drawn By<br>Dessiné Par  | BoxCad: nickz            |                              |
| Material<br>Matière  | 12 Ga Galvanized (2.5mm) |                              |
| Color<br>Couleur   | See Part List            | Finish<br>Fini See Part List |
| Description  | Detail Rev.              |                              |
| 885SP 36" x 30" Inner Panel Part   |                          |                              |
| Part Number<br>Numéro Pièce  | Rev.                     | 1                            |
| <b>885SP3630G</b>  |                          | <b>0</b>                     |

| Qty | Part Number  | Rev | Description                      | Material                 | Color     | Finish     |
|-----|--------------|-----|----------------------------------|--------------------------|-----------|------------|
| 1   | 885SP3630G-P | 0   | 885SP 36" x 30" Inner Panel Part | 12 Ga Galvanized (2.5mm) | Unpainted | Galvanized |

Parts List