

This drawing is confidential and must not be reproduced or used without the consent of EXM

Ce dessin est confidentiel et ne doit pas être reproduit ou utilisé sans le consentement de EXM

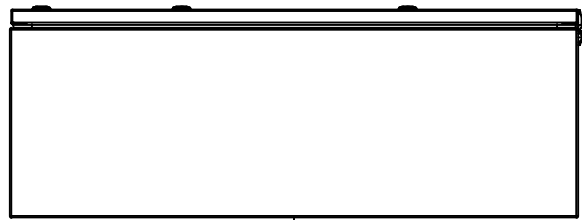

TOP

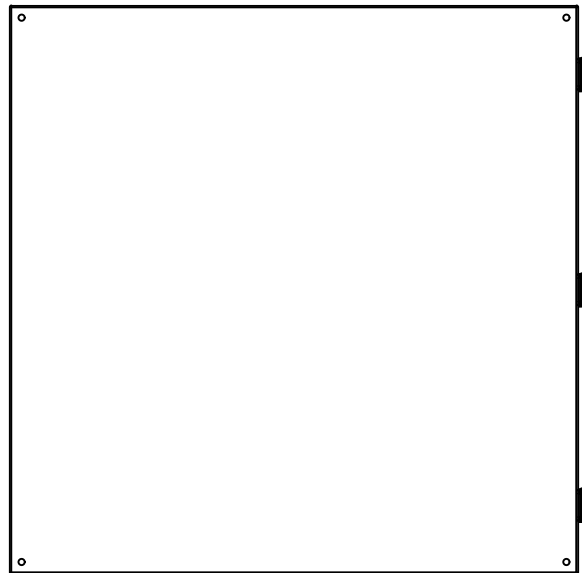

BACK

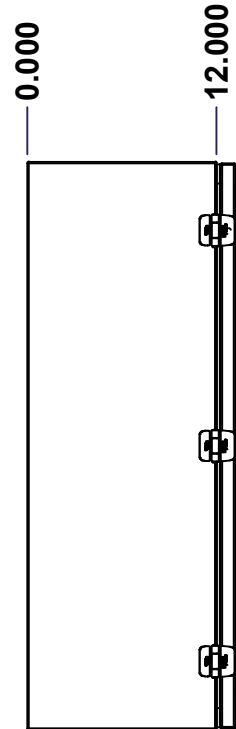

LEFT

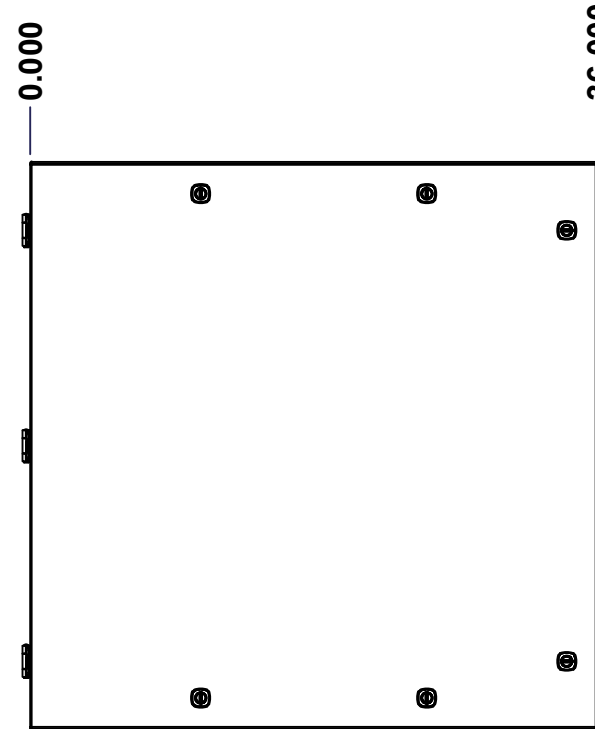

FRONT

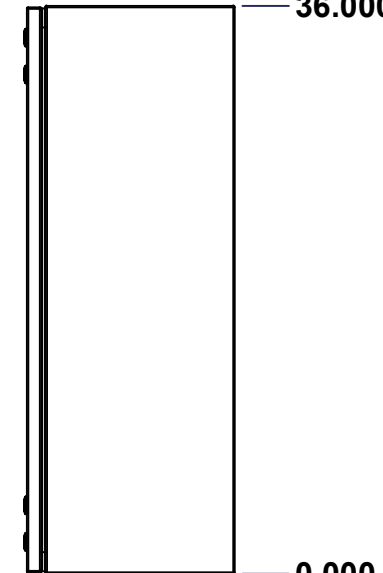

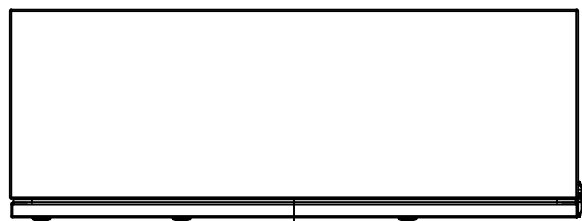

RIGHT

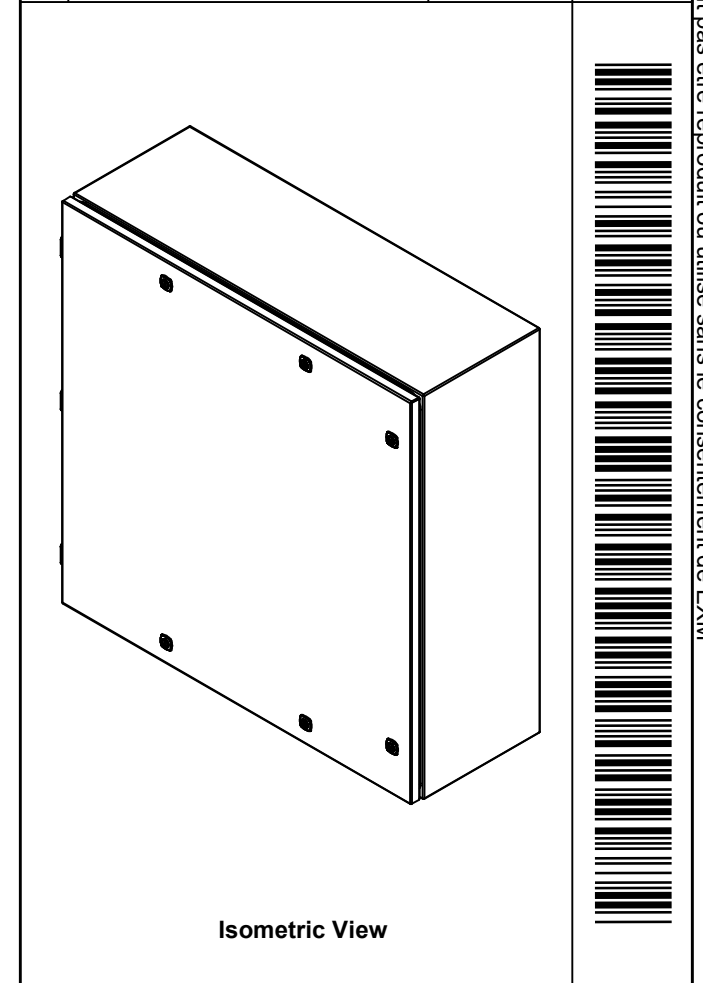

BOTTOM

No.	Revisions	Date	By/Par

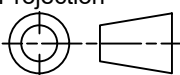

 Tél: (450) 979-4373 Fax: (450) 979-4626 <a href="http://www.exmweb.com">www.exmweb.com</a>		Flatness Aplatissement Max 3.0mm Projection 
Customer Client	Date	
Drawn By Dessiné Par	BoxCad: BoxCad	Date 04-Dec-24
Material Matière	14 Ga Cold Rolled A1008 CS Type B (1.7mm)	
Color Couleur	Asa-61 Grey	Finish Fini Smooth
Description 5412ESDG 36" x 36" x 12" Assembly		Detail Rev.
Part Number Numéro Pièce	5412ESDG363612	Rev. 1 0

SEE BILL OF MATERIAL ON LAST PAGE

This drawing is confidential and must not be reproduced or used without the consent of EXM

Ce dessin est confidentiel et ne doit pas être reproduit ou utilisé sans le consentement de EXM

NOTE	
ITEM	DESCRIPTION
1	NEMA 4, 12 Enclosure (IP66)
2	C/W Standard ground studs on box and cover
3	W/O Standard door stiffener
4	C/W Standard inner panel (Included)
5	C/W Standard inner panel mounting studs

No.	Revisions	Date	By/Par

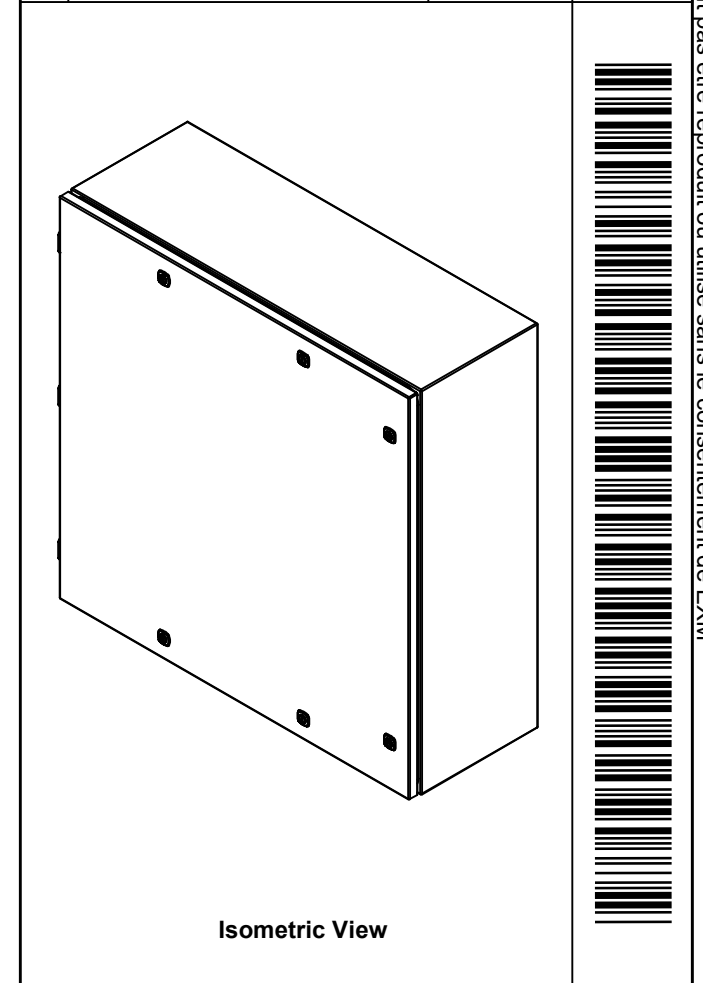



Tél: (450) 979-4373  
Fax: (450) 979-4626  
[www.exmweb.com](http://www.exmweb.com)

Flatness  
Aplatissement  
Max 3.0mm

Projection

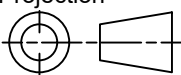

Customer Client	Date
Drawn By / Dessiné Par: BoxCad: BoxCad	Date: 04-Dec-24
Material / Matière: 14 Ga Cold Rolled A1008 CS Type B (1.7mm)	

PACKING		
ITEM	QTY	DESCRIPTION
Cardboard sleeve	2	Top and Bottom
Cardboard strip	2	Between back of enclosure and inner panel
Plastic bag	1	To protect cover surface and inside gasket
Plastic strap - Black	2	To Squeeze the 2 cardboard sleeve together
Packaging label	1	White label with product number

1	STK-K-01800	5	5412 ES Accessory Kit
1	885SP3636G	0	885SP 36" x 36" Inner Panel Part
4	STK-K-01320	0	5412 ES Inner Panel Accessory Kit
3	STK-Q-07220	1	M6 Nylon Insert Lock Nut
3	STK-Q-10252	0	M6 Stainless Steel Sealing Washer
1	5412ESDG363612C	0	5412ESDG 36" x 36" Cover
1	5412ESDG363612B	0	5412ESDG 36" x 36" x 12" Body
Qty	Part Number	Rev	Description
Parts List			

Color / Couleur: Asa-61 Grey	Finish / Fini: Smooth
Description: 5412ESDG 36" x 36" x 12" Assembly	
Part Number / Numéro Pièce: <b>5412ESDG363612</b>	Rev. 0
2 / 9	

This drawing is confidential and must not be reproduced or used without the consent of EXM

Ce dessin est confidentiel et ne doit pas être reproduit ou utilisé sans le consentement de EXM

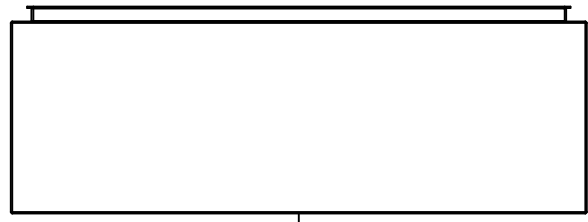

TOP

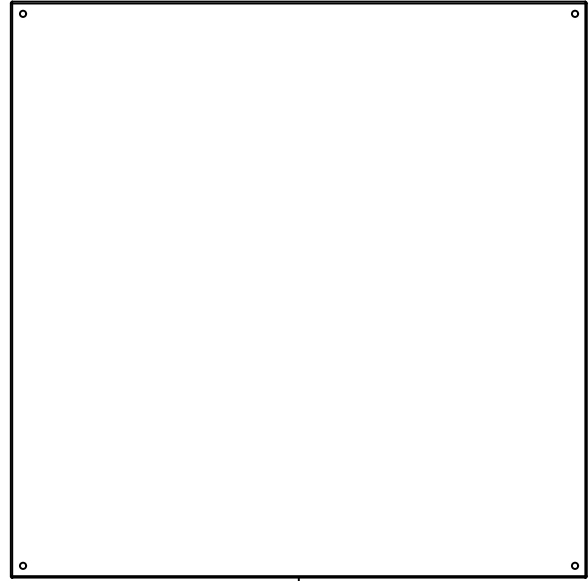

BACK

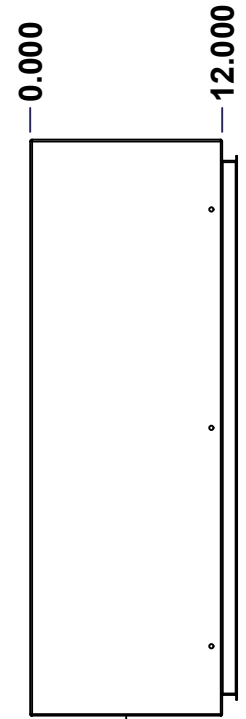

LEFT

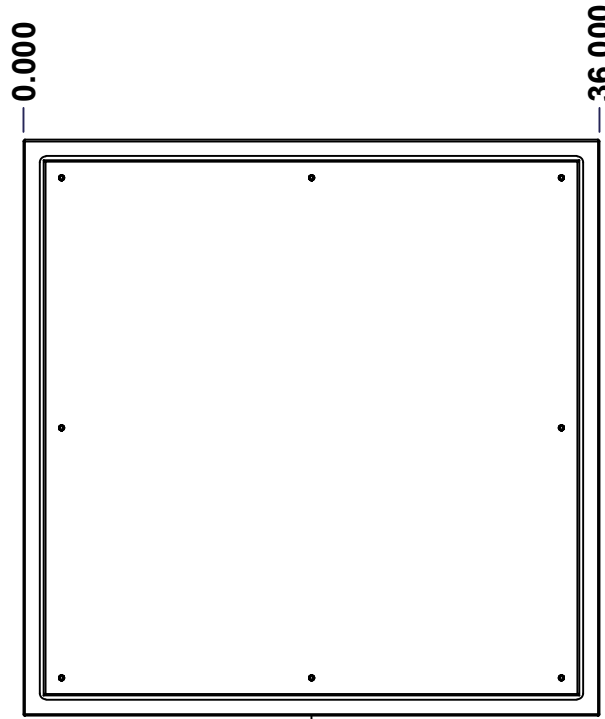

FRONT

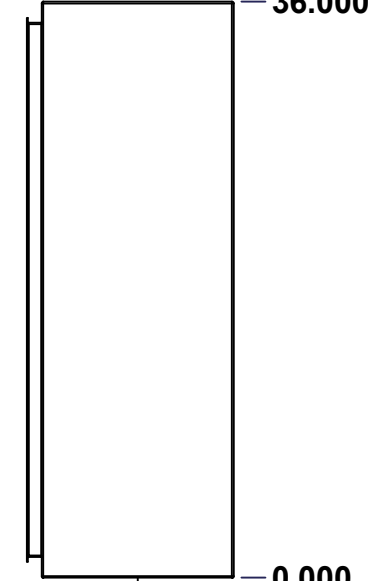

RIGHT

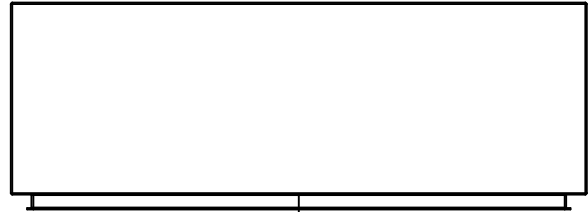

BOTTOM

No.	Revisions	Date	By/Par

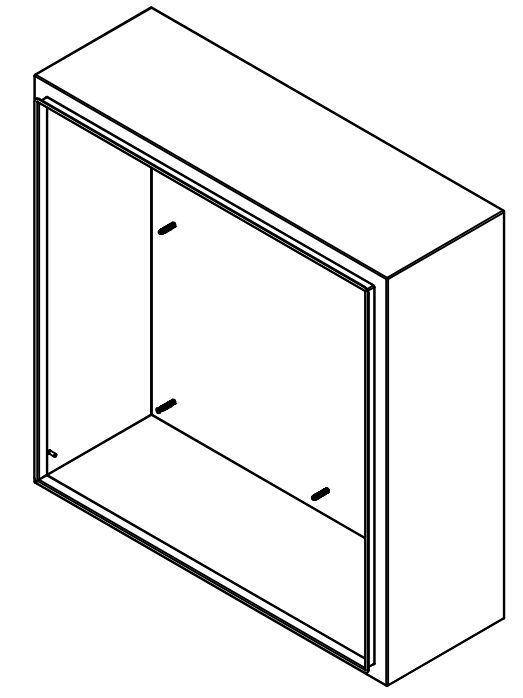

Isometric View

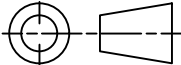

 Tél: (450) 979-4373 Fax: (450) 979-4626 <a href="http://www.exmweb.com">www.exmweb.com</a>		Flatness Aplatissement Max 3.0mm Projection 
Customer Client	Date	
Drawn By Dessiné Par	BoxCad: BoxCad	Date 04-Dec-24
Material Matière	14 Ga Cold Rolled A1008 CS Type B (1.7mm)	
Color Couleur	Asa-61 Grey	Finish Fini Smooth
Description 5412ESDG 36" x 36" x 12" Body		Detail Rev.
Part Number Numéro Pièce	5412ESDG363612B	Rev. 3 0

SEE BILL OF MATERIAL ON LAST PAGE

This drawing is confidential and must not be reproduced or used without the consent of EXM

Ce dessin est confidentiel et ne doit pas être reproduit ou utilisé sans le consentement de EXM

<b>STANDARD FEATURES ARE NOT LISTED IN THIS HOLE TABLE</b>			
<b>HOLE TABLE - LEFT VIEW (CUSTOM FEATURE ONLY)</b>			
CUT-OUT	XDIM	YDIM	DESCRIPTION
1	10.500	2.000	GND STUD M6 x 16mm (Inside)

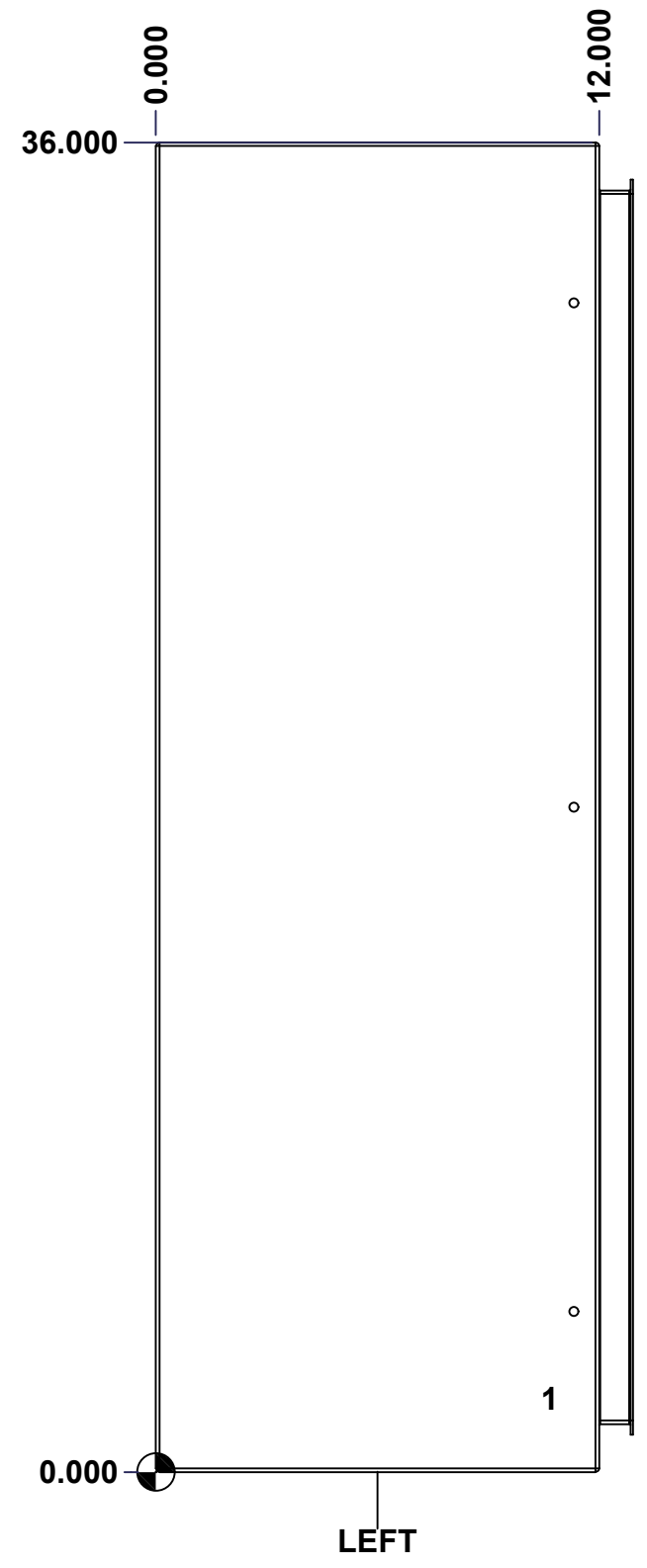

	Description		Status
	5412ESDG 36" x 36" x 12" Body		(NULL)
	Part Number Numéro Pièce		Rev.
	<b>5412ESDG363612B</b>		4 9

This drawing is confidential and must not be reproduced or used without the consent of EXM

Ce dessin est confidentiel et ne doit pas être reproduit ou utilisé sans le consentement de EXM

**STANDARD FEATURES ARE NOT LISTED IN THIS HOLE TABLE**

**HOLE TABLE - BACK VIEW (CUSTOM FEATURE ONLY)**

CUT-OUT	XDIM	YDIM	DESCRIPTION
1	2.375	2.375	IP STUD M8 x 35mm (Inside)
2	2.375	33.625	IP STUD M8 x 35mm (Inside)
3	33.625	33.625	IP STUD M8 x 35mm (Inside)
4	33.625	2.375	IP STUD M8 x 35mm (Inside)
5	2.375	18.000	IP STUD M8 x 35mm (Inside)
6	33.625	18.000	IP STUD M8 x 35mm (Inside)
7	18.000	2.375	IP STUD M8 x 35mm (Inside)
8	18.000	33.625	IP STUD M8 x 35mm (Inside)
-----			
9	35.250	0.750	RND Ø0.390
10	35.250	35.250	RND Ø0.390
11	0.750	35.250	RND Ø0.390
12	0.750	0.750	RND Ø0.390

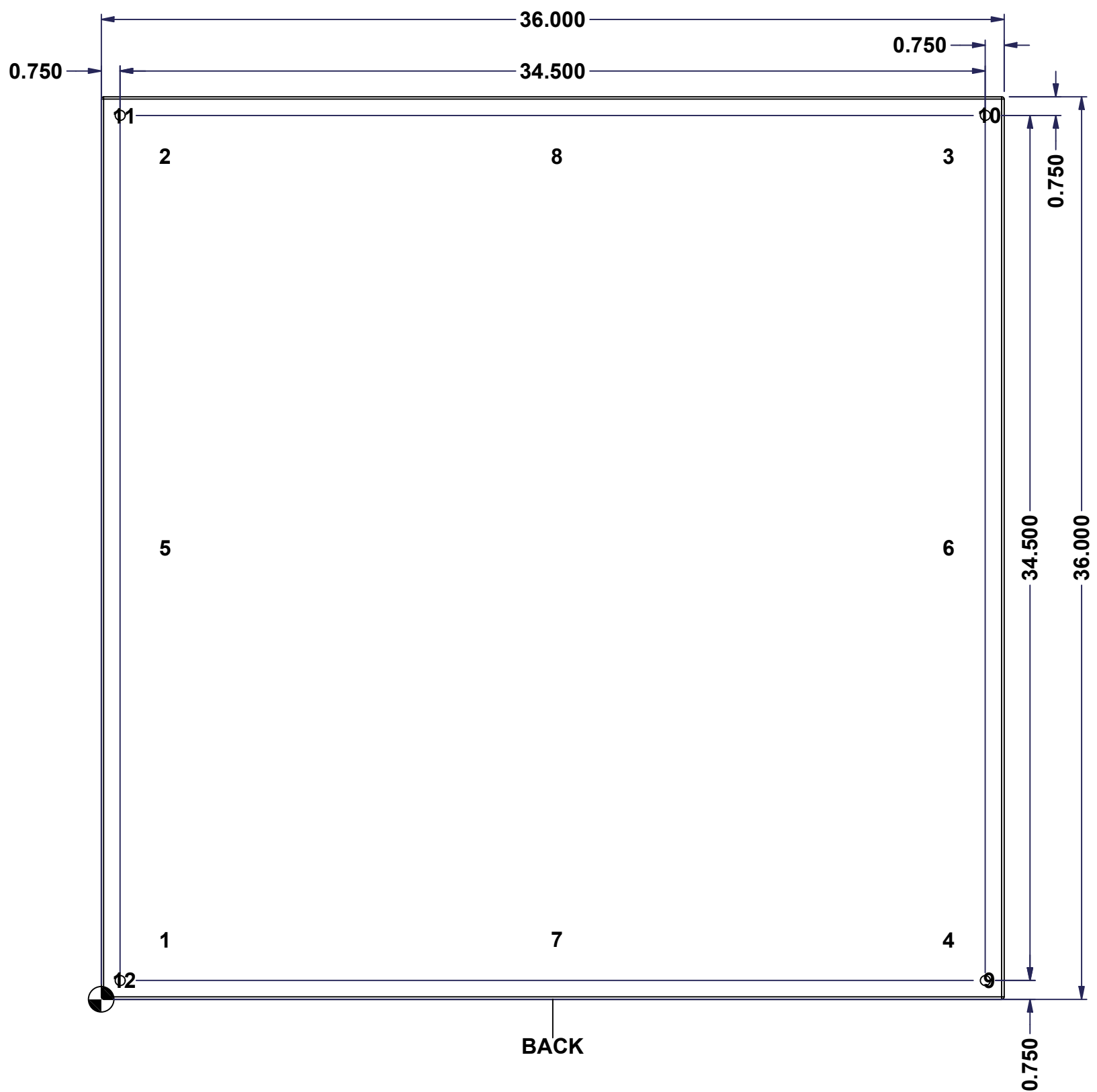



	Description	Status
	5412ESDG 36" x 36" x 12" Body	(NULL)
Part Number Numéro Pièce <b>5412ESDG363612B</b>	Rev.	5
	<b>0</b>	9

This drawing is confidential and must not be reproduced or used without the consent of EXM

Ce dessin est confidentiel et ne doit pas être reproduit ou utilisé sans le consentement de EXM

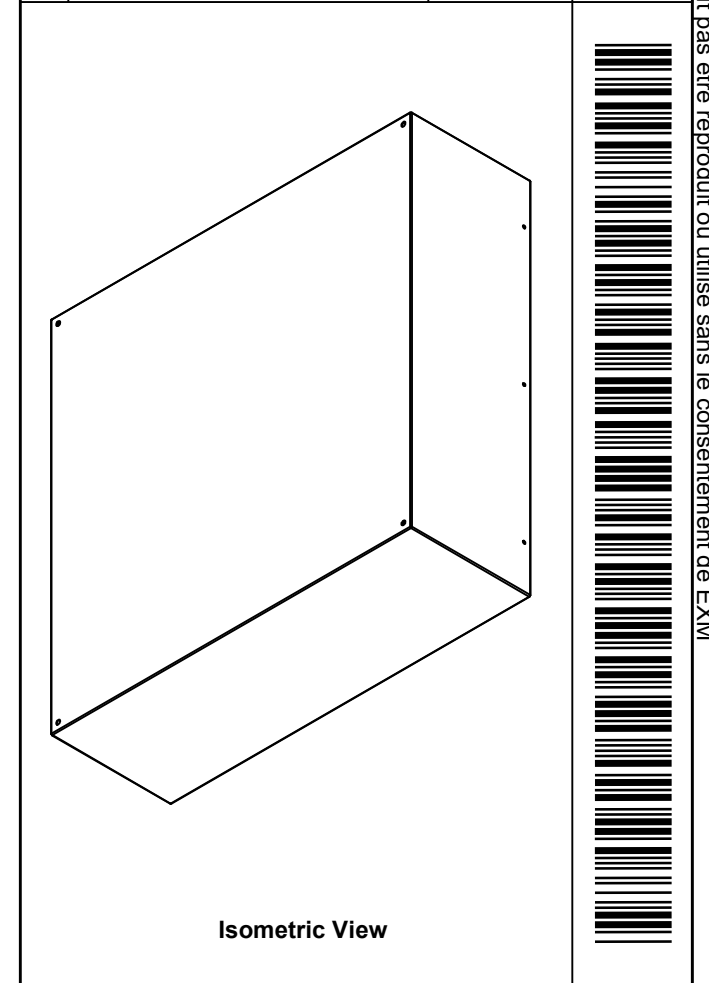
No.	Revisions	Date	By/Par

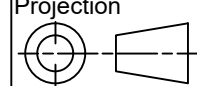

 Tél: (450) 979-4373 Fax: (450) 979-4626 <a href="http://www.exmweb.com">www.exmweb.com</a>		Flatness Aplatissement Max 3.0mm
Customer Client		Projection 
Drawn By / Dessiné Par: BoxCad: BoxCad		Date: 04-Dec-24
Material / Matière: 14 Ga Cold Rolled A1008 CS Type B (1.7mm)		
Color / Couleur: Asa-61 Grey	Finish / Fini: Smooth	
Description: 5412ESDG 36" x 36" x 12" Body		Detail Rev.
Part Number / Numéro Pièce: <b>5412ESDG363612B</b>		Rev. 6 / 9

Qty	Part Number	Rev	Description
1	STK-Q-16080	0	Ground Stud M6 x 16mm Steel
1	STK-P-02400S	0	Powder Paint (Asa-61 Grey / Smooth)
8	STK-Q-16005	0	Stud M8 x 35mm Steel
1	5412ESDG363612B-P	0	5412ESDG 36" x 36" x 12" Body Part
Parts List			

This drawing is confidential and must not be reproduced or used without the consent of EXM

Ce dessin est confidentiel et ne doit pas être reproduit ou utilisé sans le consentement de EXM

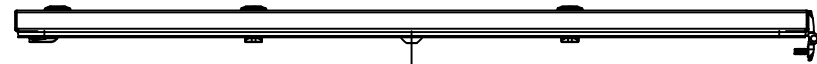

TOP

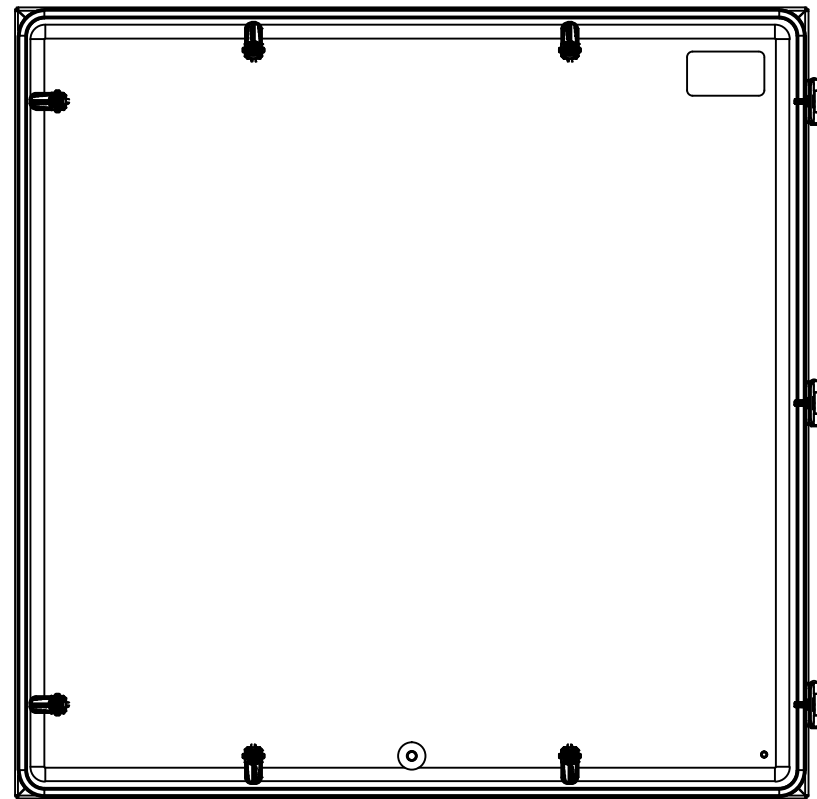

BACK

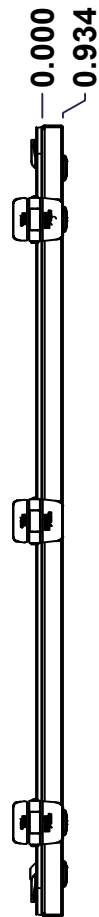

LEFT

0.000  
0.934

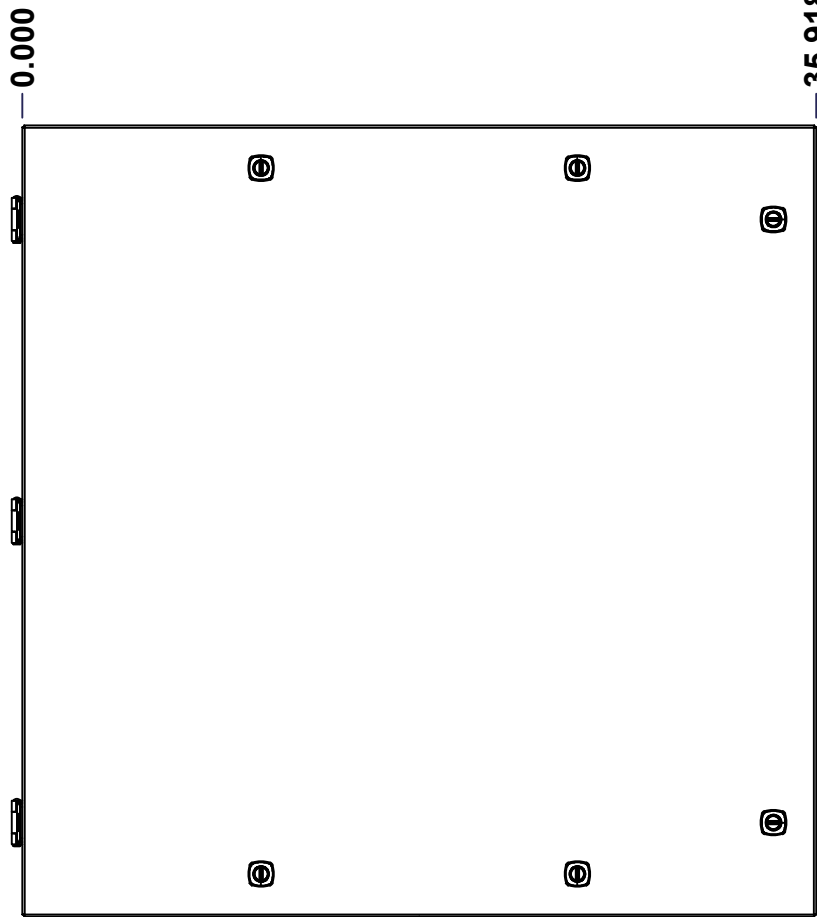

FRONT

0.000

35.918

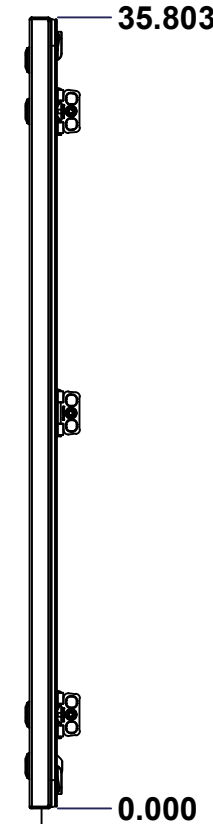

RIGHT

35.803

0.000



BOTTOM

No.	Revisions	Date	By/Par

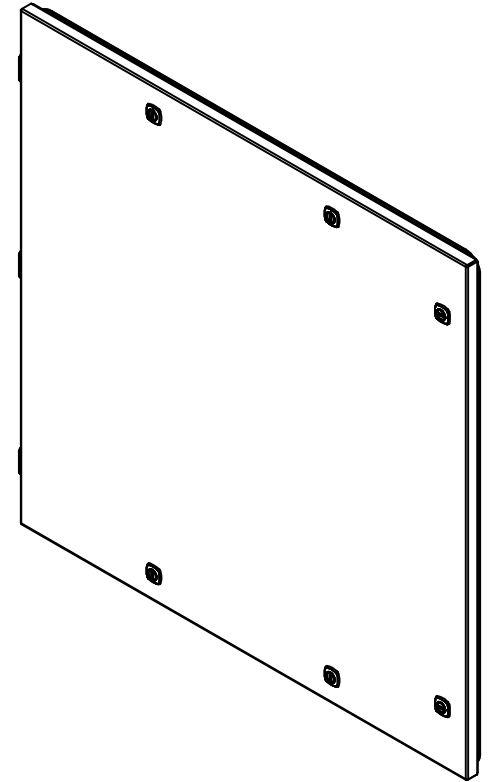

Isometric View



Tél: (450) 979-4373  
Fax: (450) 979-4626  
[www.exmweb.com](http://www.exmweb.com)

Flatness  
Aplatissement  
Max 3.0mm  
Projection

Customer Client	Date
Drawn By / Dessiné Par: BoxCad: BoxCad	Date: 04-Dec-24
Material / Matière: 14 Ga Cold Rolled A1008 CS Type B (1.7mm)	

Color / Couleur: Asa-61 Grey	Finish / Fini: Smooth
------------------------------	-----------------------

Description: 5412ESDG 36" x 36" Cover	Detail Rev.
---------------------------------------	-------------

Part Number / Numéro Pièce: 5412ESDG363612C	Rev. 0	7 / 9
---	--------	-------

SEE BILL OF MATERIAL ON LAST PAGE

This drawing is confidential and must not be reproduced or used without the consent of EXM

Ce dessin est confidentiel et ne doit pas être reproduit ou utilisé sans le consentement de EXM

**STANDARD FEATURES ARE NOT LISTED IN THIS HOLE TABLE**

**HOLE TABLE - FRONT VIEW (CUSTOM FEATURE ONLY)**

CUT-OUT	XDIM	YDIM	DESCRIPTION
1	17.959	1.435	STUD M6 x 18mm (Inside)
-----			
2	25.118	1.924	LOCK 880 SCQ4-SL @ 270.0°
3	2.000	2.000	GND STUD M6 x 16mm (Inside)
4	3.750	32.803	LABEL_EXM (Inside)
5	33.994	31.553	LOCK 880 SCQ4-SL @ 0.0°
6	33.994	4.250	LOCK 880 SCQ4-SL @ 0.0°
7	10.800	33.879	LOCK 880 SCQ4-SL @ 90.0°
8	25.118	33.879	LOCK 880 SCQ4-SL @ 90.0°
9	10.800	1.924	LOCK 880 SCQ4-SL @ 270.0°

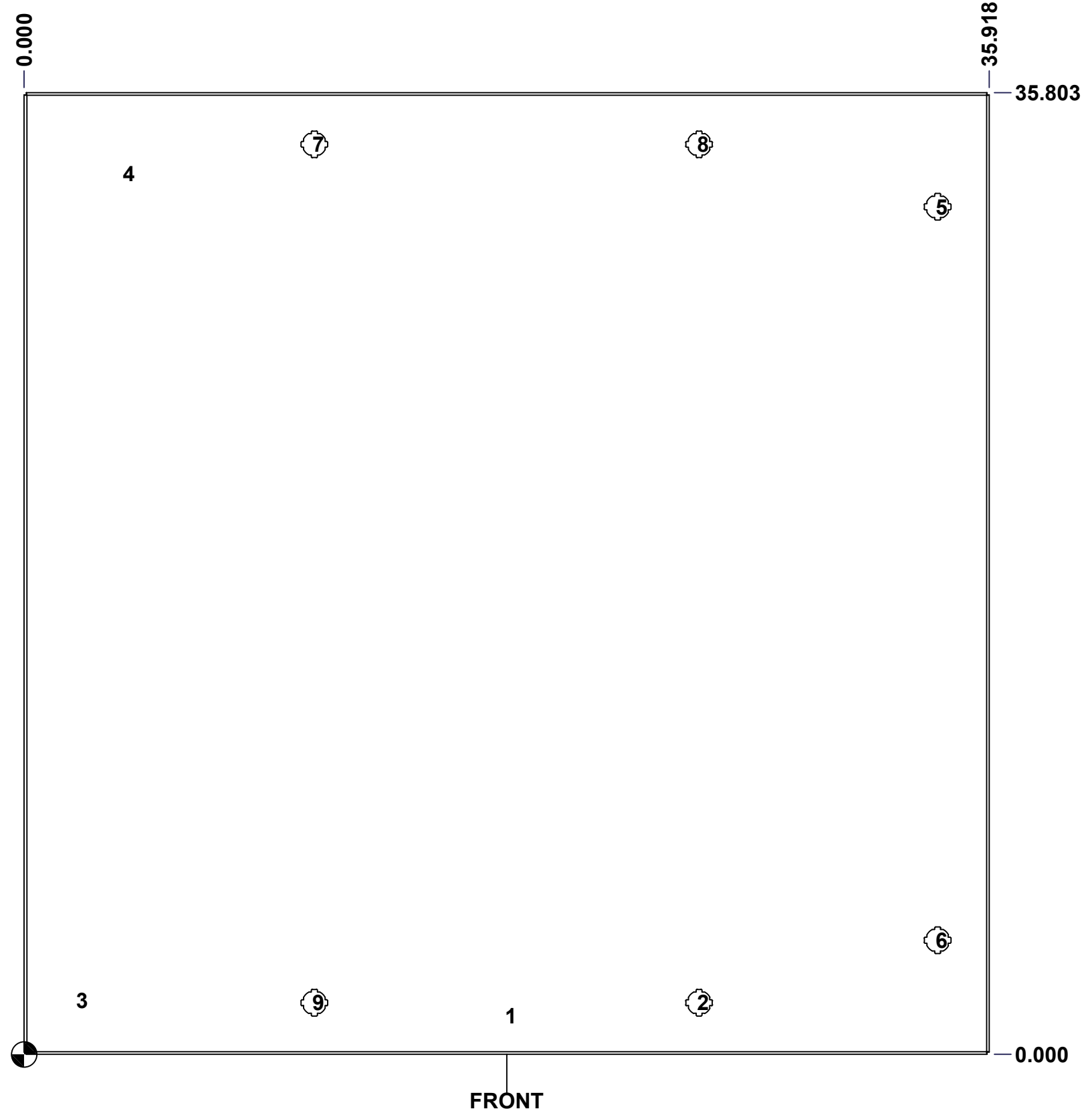

FRONT

	Description	Status	
	5412ESDG 36" x 36" Cover	(NULL)	
	Part Number Numéro Pièce	Rev.	
	<b>5412ESDG363612C</b>	<b>0</b>	8 9

This drawing is confidential and must not be reproduced or used without the consent of EXM

Ce dessin est confidentiel et ne doit pas être reproduit ou utilisé sans le consentement de EXM

No.	Revisions	Date	By/Par

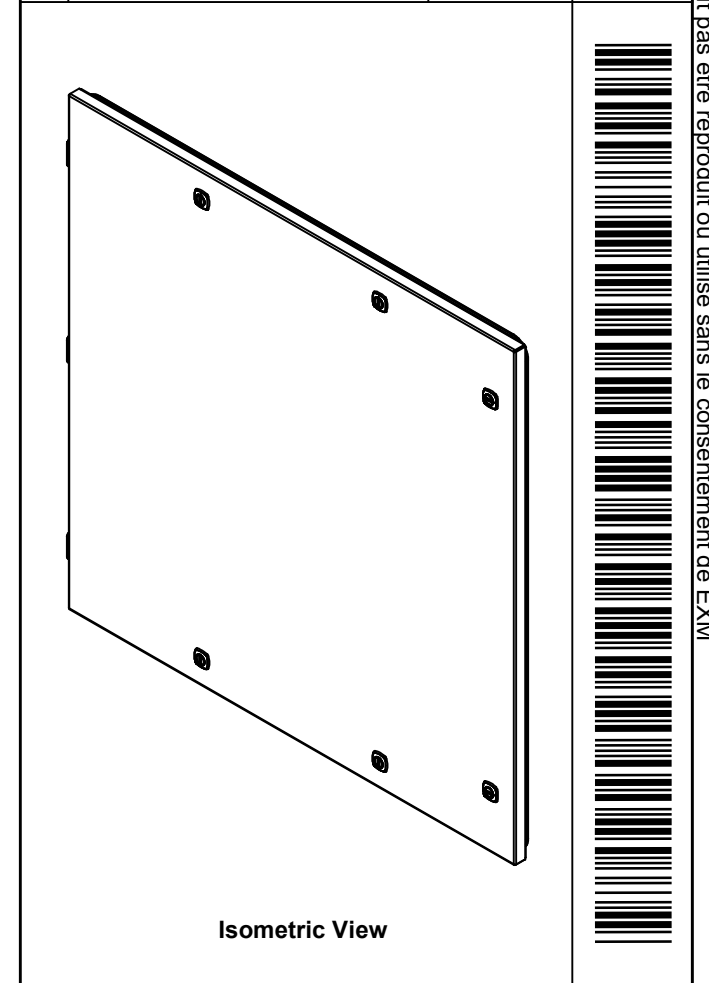

1	STK-S-00100	0	3.5" x 2" Silver Milar Flexcon Sticker
1	STK-Q-16080	0	Ground Stud M6 x 16mm Steel
6	STK-K-12500	19	5412 ES 1/4 Turn Lock
1	STK-P-02400S	0	Powder Paint (Asa-61 Grey / Smooth)
1	STK-Q-46515	3	5412 ES Door Support with Brass Insert
1	STK-Q-16055	1	M6 x 18mm Stud (No Paint Cap Required)
3	STK-Q-07220	1	M6 Nylon Insert Lock Nut
3	STK-Q-10252	0	M6 Stainless Steel Sealing Washer
3	STK-A-02360	2	External Hinge for Double Gasket
1	5412ESDG363612G2	0	5412ESDG 36" x 36" Cover Gasket
1	5412ESDG363612G	0	5412ESDG 36" x 36" Cover Gasket
1	5412ESDG363612C-P	0	5412ESDG 36" x 36" Cover Part
QTY	Part Number	Rev	Description
Parts List			

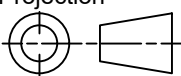
 Tél: (450) 979-4373 Fax: (450) 979-4626 <a href="http://www.exmweb.com">www.exmweb.com</a>		Flatness Aplatissement Max 3.0mm Projection 
Customer Client	Date	
Drawn By Dessiné Par	BoxCad: BoxCad	Date 04-Dec-24
Material Matière	14 Ga Cold Rolled A1008 CS Type B (1.7mm)	
Color Couleur	Asa-61 Grey	Finish Fini Smooth
Description		Detail Rev.
5412ESDG 36" x 36" Cover		
Part Number Numéro Pièce	Rev.	9
<b>5412ESDG363612C</b>	<b>0</b>	9

This drawing is confidential and must not be reproduced or used without the consent of EXM

Ce dessin est confidentiel et ne doit pas être reproduit ou utilisé sans le consentement de EXM

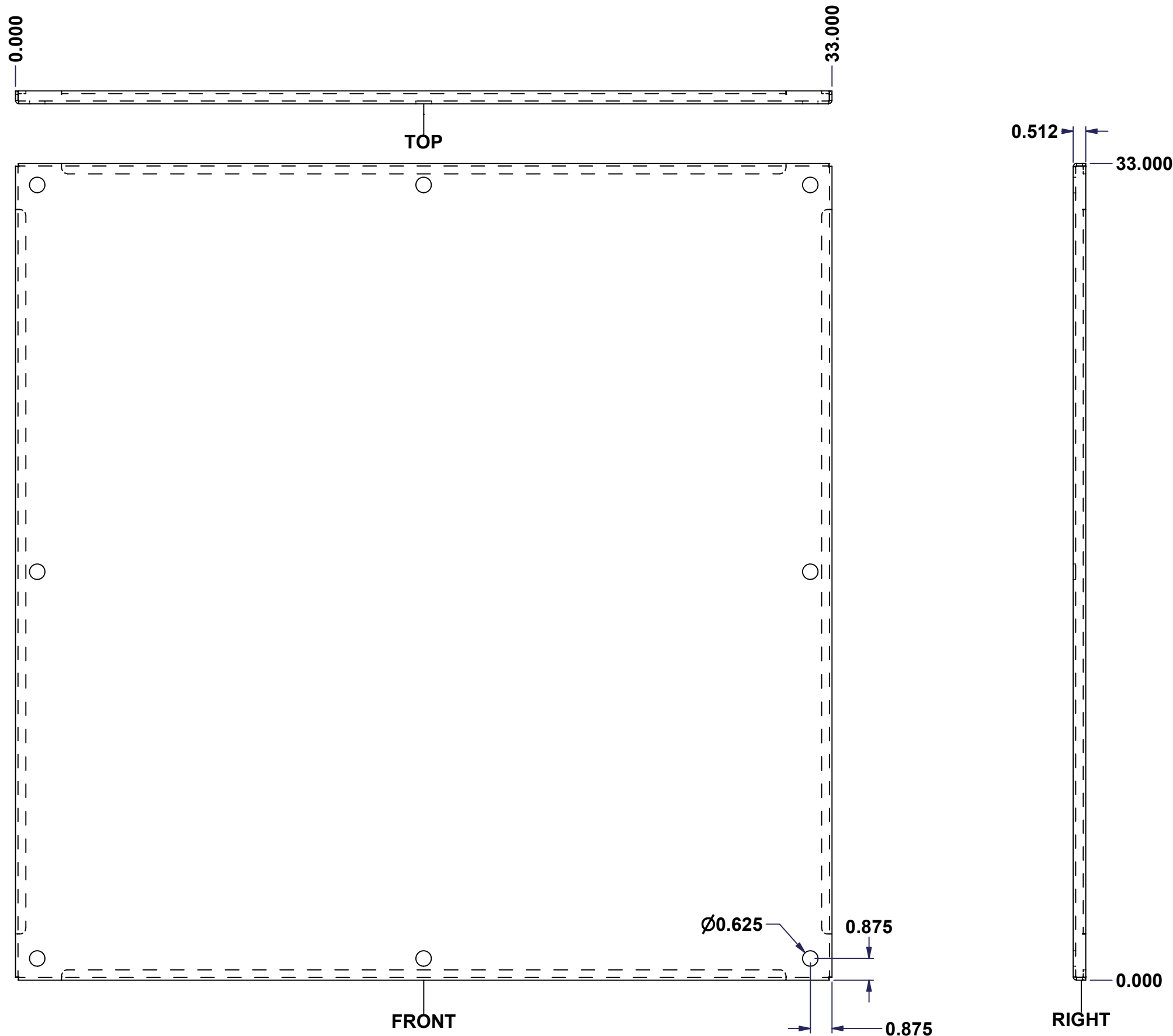

No.	Revisions	Date	By/Par

**Isometric View**

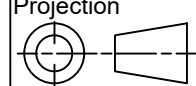

		Flatness Aplatissement Max 3.0mm	
Tél: (450) 979-4373 Fax: (450) 979-4626 <a href="http://www.exmweb.com">www.exmweb.com</a>		Projection 	
Customer Client		Date	
Drawn By / Dessiné Par: BoxCad: nickz		Date: 01/03/2017	
Material / Matière: 12 Ga Galvanized (2.5mm)			
Color / Couleur: See Part List		Finish / Fini: See Part List	
Description: 885SP 36" x 36" Inner Panel Part			Detail Rev.
Part Number / Numéro Pièce: <b>885SP3636G</b>			Rev. 1

Qty	Part Number	Rev	Description	Material	Color	Finish
1	885SP3636G-P	0	885SP 36" x 36" Inner Panel Part	12 Ga Galvanized (2.5mm)	Unpainted	Galvanized

Parts List