

This drawing is confidential and must not be reproduced or used without the consent of EXM

Ce dessin est confidentiel et ne doit pas être reproduit ou utilisé sans le consentement de EXM

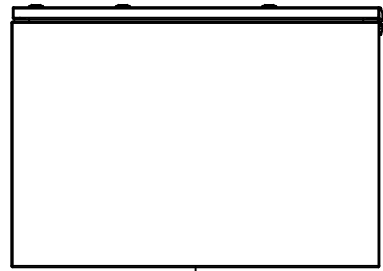

TOP

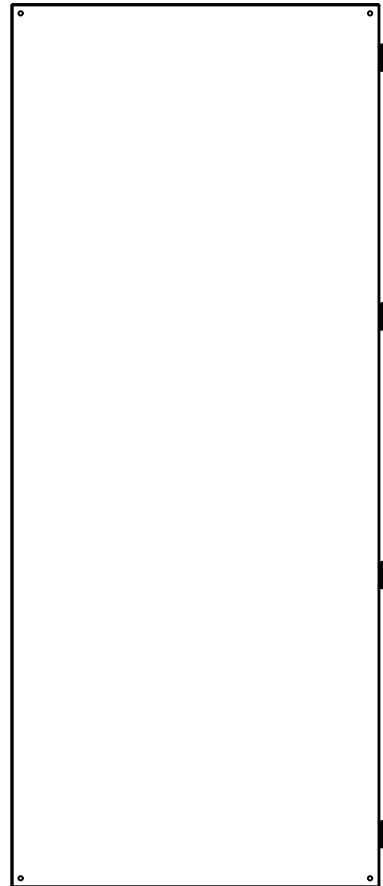

BACK

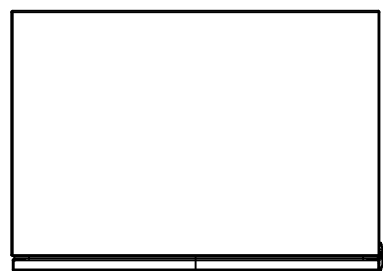

BOTTOM

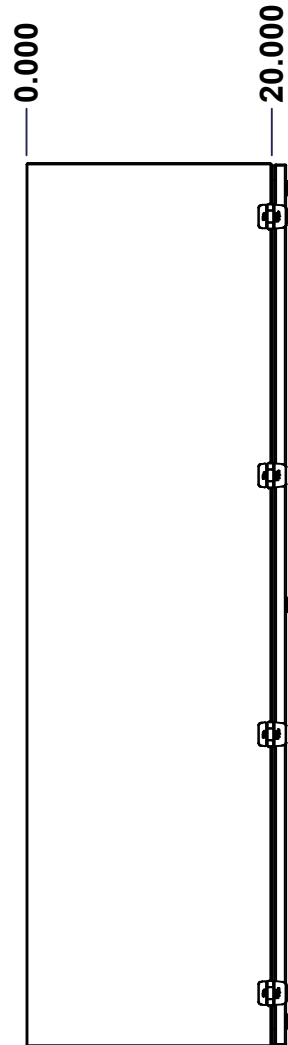

LEFT

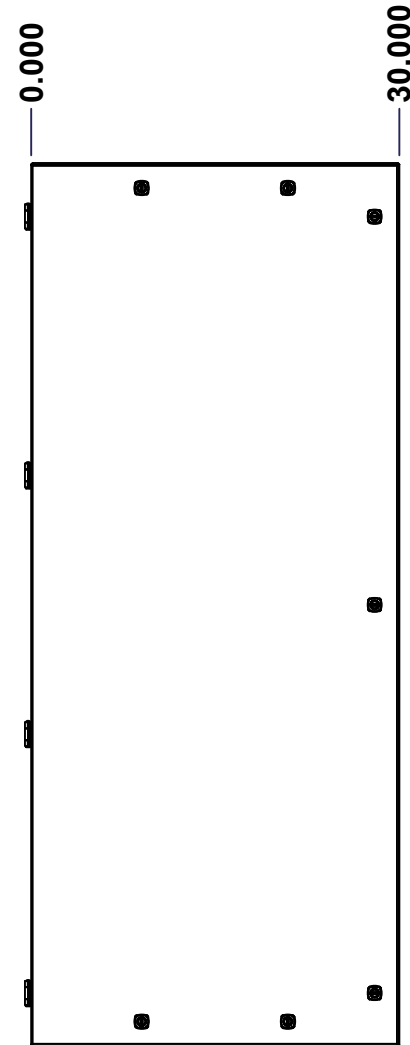

FRONT

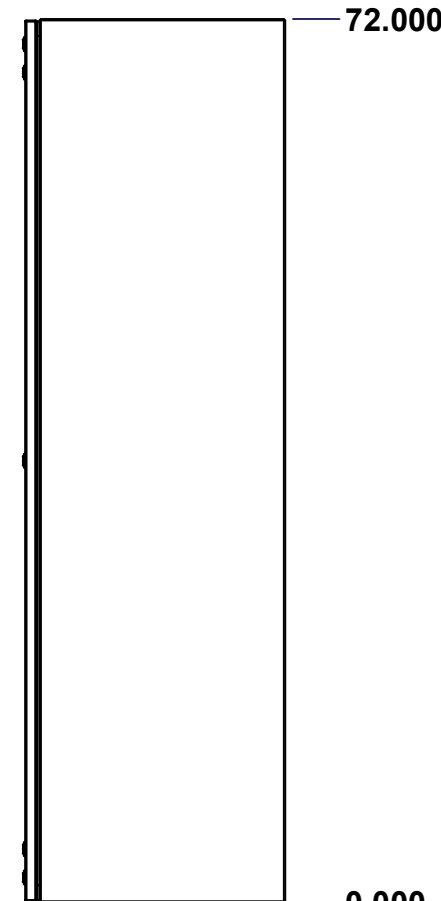

RIGHT

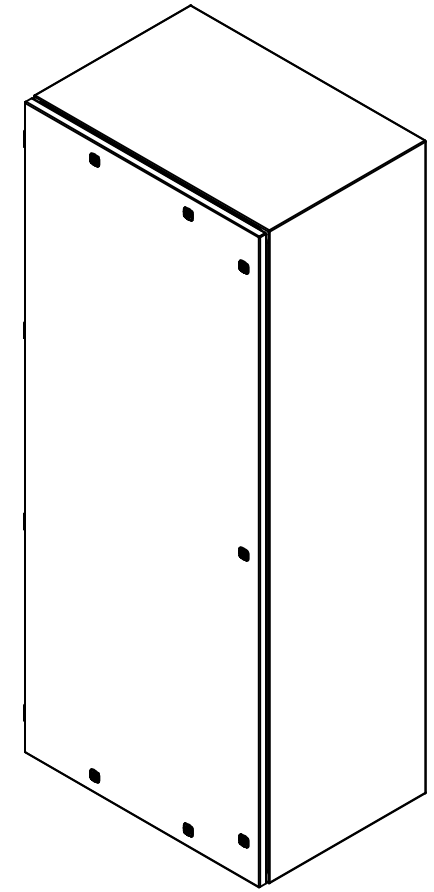

Isometric View

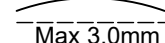
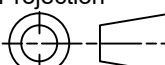

No.	Revisions	Date	By/Par

 Tél: (450) 979-4373 Fax: (450) 979-4626 <a href="http://www.exmweb.com">www.exmweb.com</a>		Flatness Aplatissement  Max 3.0mm Projection 
Customer Client	Date	
Drawn By Dessiné Par	BoxCad: BoxCad	Date 05-Dec-24
Material Matière	14 Ga Cold Rolled A1008 CS Type B (1.7mm)	
Color Couleur	Asa-61 Grey	Finish Fini Smooth
Description	Detail Rev.	
5412ESDG 72" x 30" x 20" Assembly		
Part Number Numéro Pièce	Rev.	1
5412ESDG723020	0	9

SEE BILL OF MATERIAL ON LAST PAGE

This drawing is confidential and must not be reproduced or used without the consent of EXM

Ce dessin est confidentiel et ne doit pas être reproduit ou utilisé sans le consentement de EXM

NOTE	
ITEM	DESCRIPTION
1	NEMA 4, 12 Enclosure (IP66)
2	C/W Standard ground studs on box and cover
3	W/O Standard door stiffener
4	C/W Standard inner panel (Included)
5	C/W Standard inner panel mounting studs

No.	Revisions	Date	By/Par

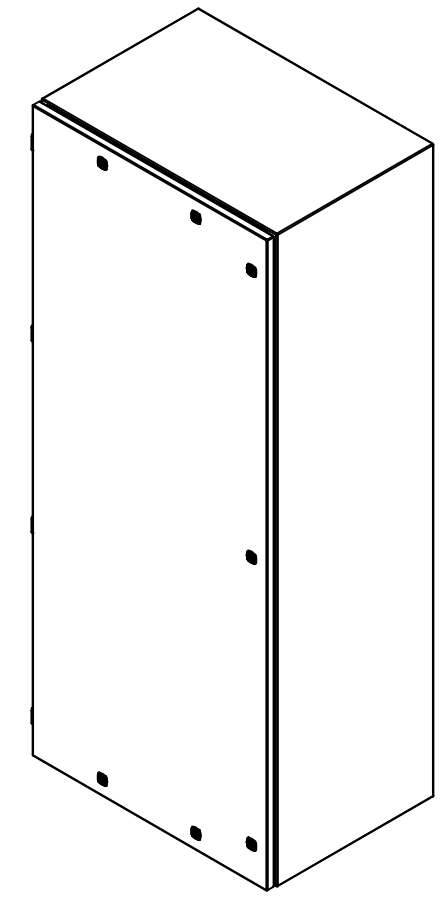

Isometric View



PACKING		
ITEM	QTY	DESCRIPTION
Cardboard sleeve	2	Top and Bottom
Cardboard strip	2	Between back of enclosure and inner panel
Plastic bag	1	To protect cover surface and inside gasket
Cardboard corner	4	To reinforced for the plastic strap tightening
Plastic strap - Black	2	To Squeeze the 2 cardboard sleeve together
Packaging label	3	White label with PN
Plastic strap- Green	2	To secure the enclosure to the wood pallet
Wood Pallet	1	2" deeper and 3" larger than enclosure size

1	STK-K-01800	5	5412 ES Accessory Kit
1	885SP7230G	0	885SP 72" x 30" Inner Panel Part
3	STK-K-01320	0	5412 ES Inner Panel Accessory Kit
4	STK-Q-07220	1	M6 Nylon Insert Lock Nut
4	STK-Q-10252	0	M6 Stainless Steel Sealing Washer
1	5412ESDG723020C	0	5412ESDG 72" x 30" Cover
1	5412ESDG723020B	0	5412ESDG 72" x 30" x 20" Body
Qty	Part Number	Rev	Description
Parts List			

		Flatness Aplatissement Max 3.0mm	
Tél: (450) 979-4373 Fax: (450) 979-4626 <a href="http://www.exmweb.com">www.exmweb.com</a>		Projection 	
Customer Client		Date	
Drawn By Dessiné Par BoxCad: BoxCad		Date 05-Dec-24	
Material Matière		14 Ga Cold Rolled A1008 CS Type B (1.7mm)	
Color Couleur	Asa-61 Grey	Finish Fini	Smooth
Description			Detail Rev.
5412ESDG 72" x 30" x 20" Assembly			
Part Number Numéro Pièce		Rev.	2
<b>5412ESDG723020</b>		<b>0</b>	9

This drawing is confidential and must not be reproduced or used without the consent of EXM

Ce dessin est confidentiel et ne doit pas être reproduit ou utilisé sans le consentement de EXM

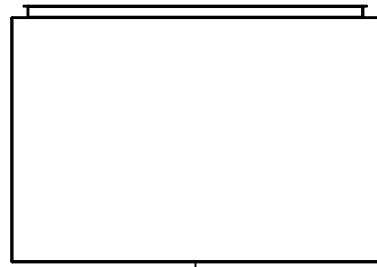

TOP



BACK

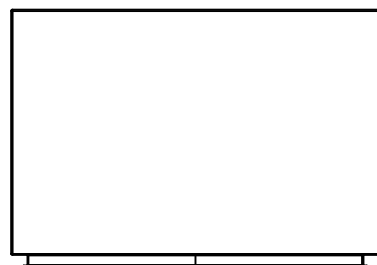

BOTTOM

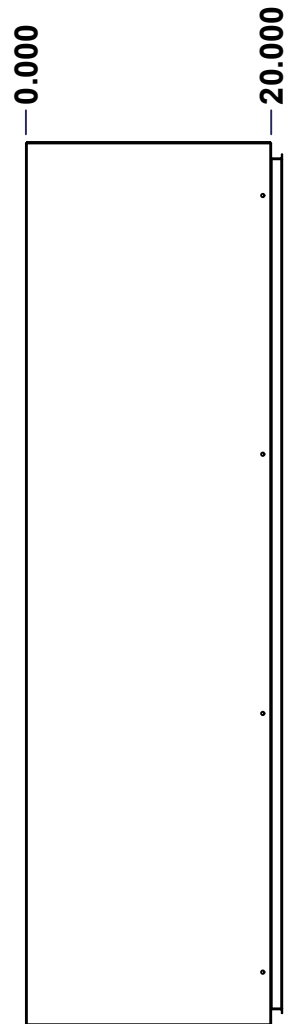

LEFT

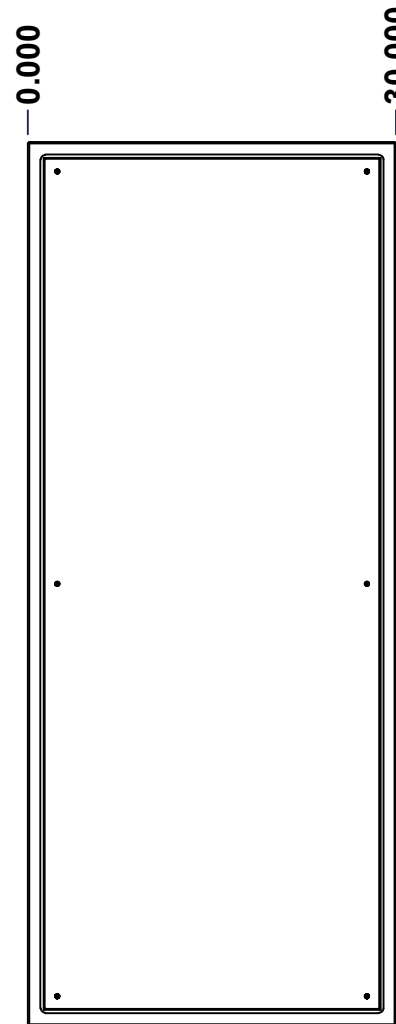

FRONT

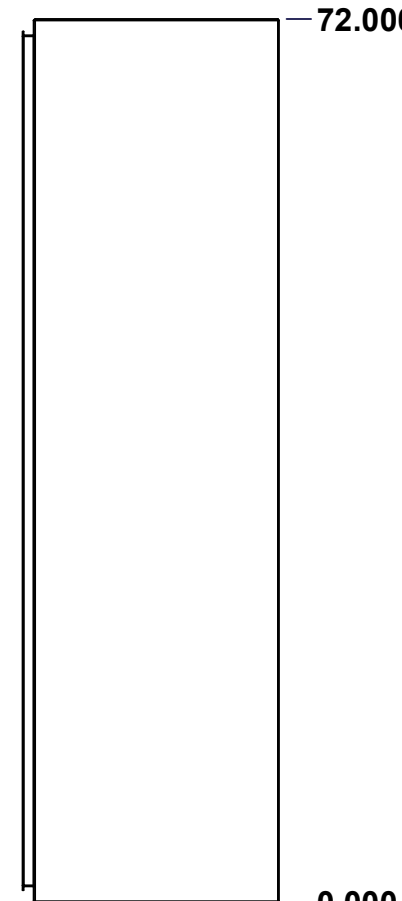

RIGHT

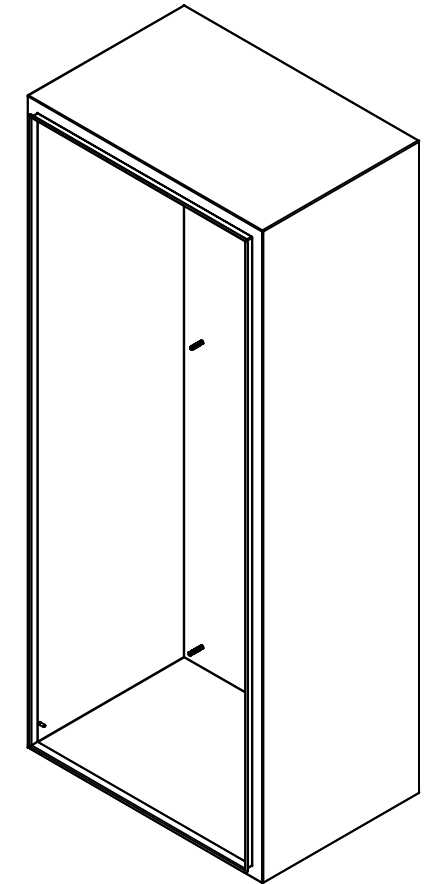

Isometric View

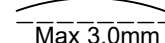
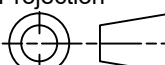

No.	Revisions	Date	By/Par

 Tél: (450) 979-4373 Fax: (450) 979-4626 <a href="http://www.exmweb.com">www.exmweb.com</a>		Flatness Aplatissement  Max 3.0mm Projection 
Customer Client	Date	
Drawn By Dessiné Par	BoxCad: BoxCad	Date 05-Dec-24
Material Matière	14 Ga Cold Rolled A1008 CS Type B (1.7mm)	
Color Couleur	Asa-61 Grey	Finish Fini Smooth
Description	Detail Rev.	
5412ESDG 72" x 30" x 20" Body		
Part Number Numéro Pièce	Rev.	3
5412ESDG723020B	0	9

SEE BILL OF MATERIAL ON LAST PAGE

This drawing is confidential and must not be reproduced or used without the consent of EXM

Ce dessin est confidentiel et ne doit pas être reproduit ou utilisé sans le consentement de EXM

**STANDARD FEATURES ARE NOT LISTED IN THIS HOLE TABLE**

**HOLE TABLE - LEFT VIEW (CUSTOM FEATURE ONLY)**

CUT-OUT	XDIM	YDIM	DESCRIPTION
1	18.500	2.000	GND STUD M6 x 16mm (Inside)

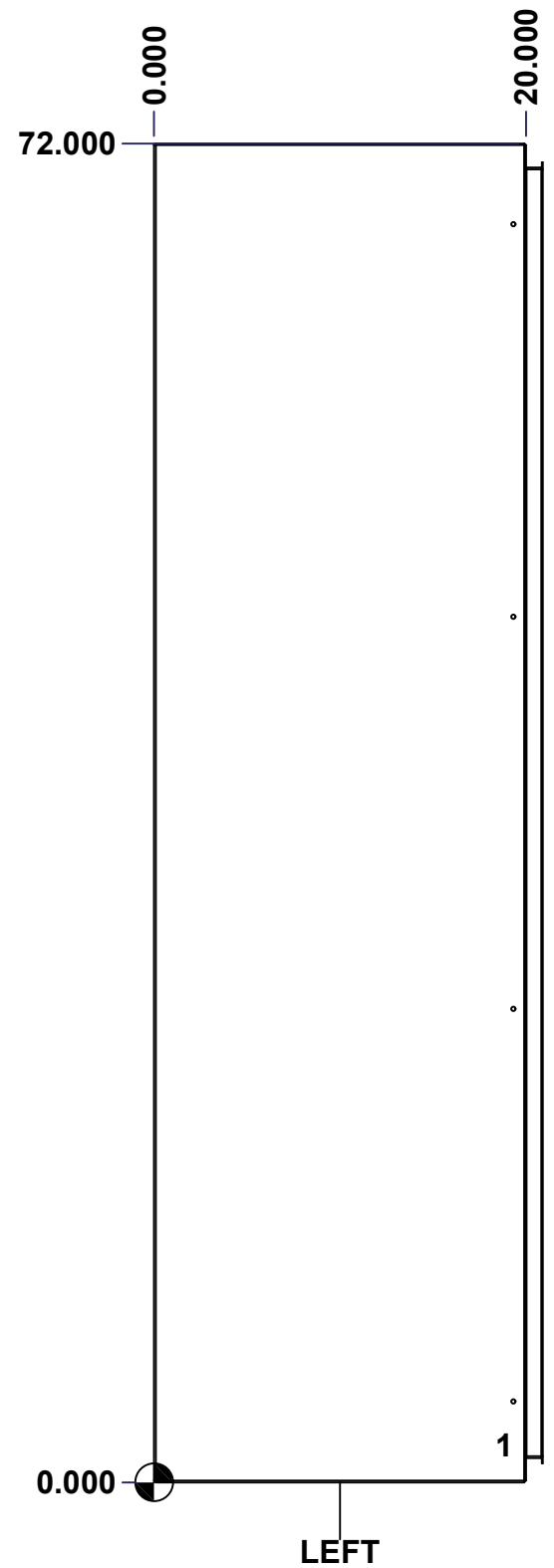

	Description		Status
	5412ESDG 72" x 30" x 20" Body		(NULL)
Part Number Numéro Pièce		Rev.	
<b>5412ESDG723020B</b>		<b>0</b>	4 9

This drawing is confidential and must not be reproduced or used without the consent of EXM

Ce dessin est confidentiel et ne doit pas être reproduit ou utilisé sans le consentement de EXM

**STANDARD FEATURES ARE NOT LISTED IN THIS HOLE TABLE**

**HOLE TABLE - BACK VIEW (CUSTOM FEATURE ONLY)**

CUT-OUT	XDIM	YDIM	DESCRIPTION
1	2.375	2.375	IP STUD M8 x 35mm (Inside)
2	2.375	69.625	IP STUD M8 x 35mm (Inside)
3	27.625	69.625	IP STUD M8 x 35mm (Inside)
4	27.625	2.375	IP STUD M8 x 35mm (Inside)
5	2.375	36.000	IP STUD M8 x 35mm (Inside)
6	27.625	36.000	IP STUD M8 x 35mm (Inside)
-----			
7	29.250	71.250	RND Ø0.390
8	29.250	0.750	RND Ø0.390
9	0.750	0.750	RND Ø0.390
10	0.750	71.250	RND Ø0.390

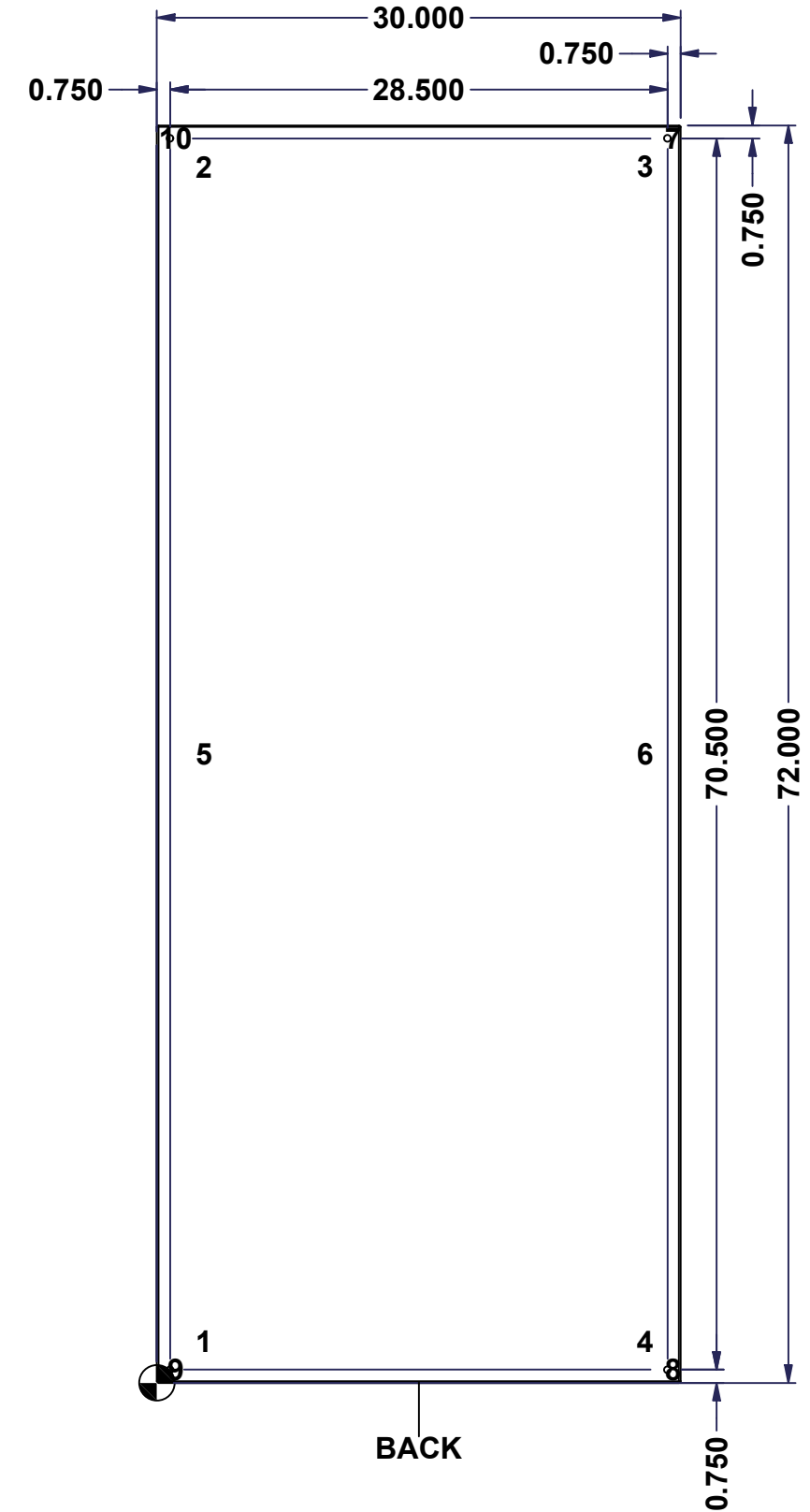

	Description	Status	
	5412ESDG 72" x 30" x 20" Body	(NULL)	
	Part Number Numéro Pièce	Rev.	
	<b>5412ESDG723020B</b>	<b>0</b>	5 9

This drawing is confidential and must not be reproduced or used without the consent of EXM

Ce dessin est confidentiel et ne doit pas être reproduit ou utilisé sans le consentement de EXM

No.	Revisions	Date	By/Par

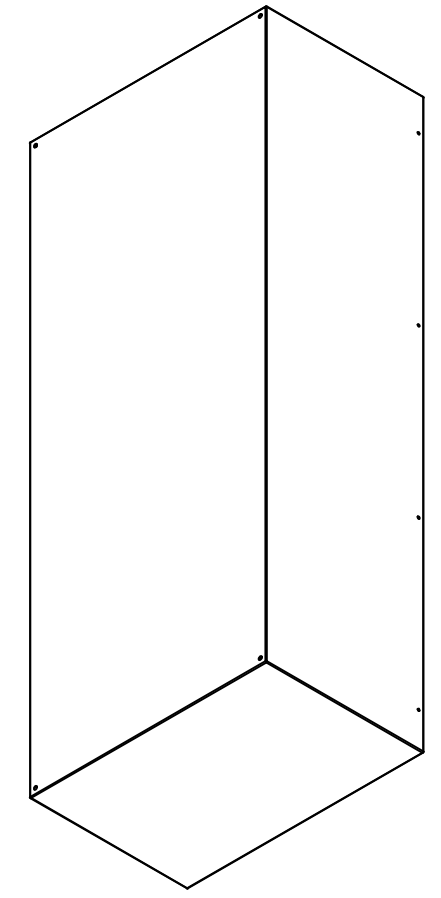

Isometric View

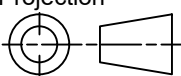

 Tél: (450) 979-4373 Fax: (450) 979-4626 <a href="http://www.exmweb.com">www.exmweb.com</a>		Flatness Aplatissement Max 3.0mm
Customer Client		Projection 
Drawn By / Dessiné Par: BoxCad: BoxCad		Date: 05-Dec-24
Material / Matière: 14 Ga Cold Rolled A1008 CS Type B (1.7mm)		
Color / Couleur: Asa-61 Grey	Finish / Fini: Smooth	
Description: 5412ESDG 72" x 30" x 20" Body		Detail Rev.
Part Number / Numéro Pièce: <b>5412ESDG723020B</b>		Rev. 6 / 9

Qty	Part Number	Rev	Description
1	STK-Q-16080	0	Ground Stud M6 x 16mm Steel
1	STK-P-02400S	0	Powder Paint (Asa-61 Grey / Smooth)
6	STK-Q-16005	0	Stud M8 x 35mm Steel
1	5412ESDG723020B-P	0	5412ESDG 72" x 30" x 20" Body Part
Parts List			

This drawing is confidential and must not be reproduced or used without the consent of EXM

Ce dessin est confidentiel et ne doit pas être reproduit ou utilisé sans le consentement de EXM

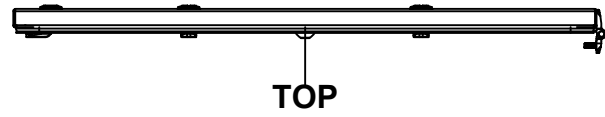

TOP

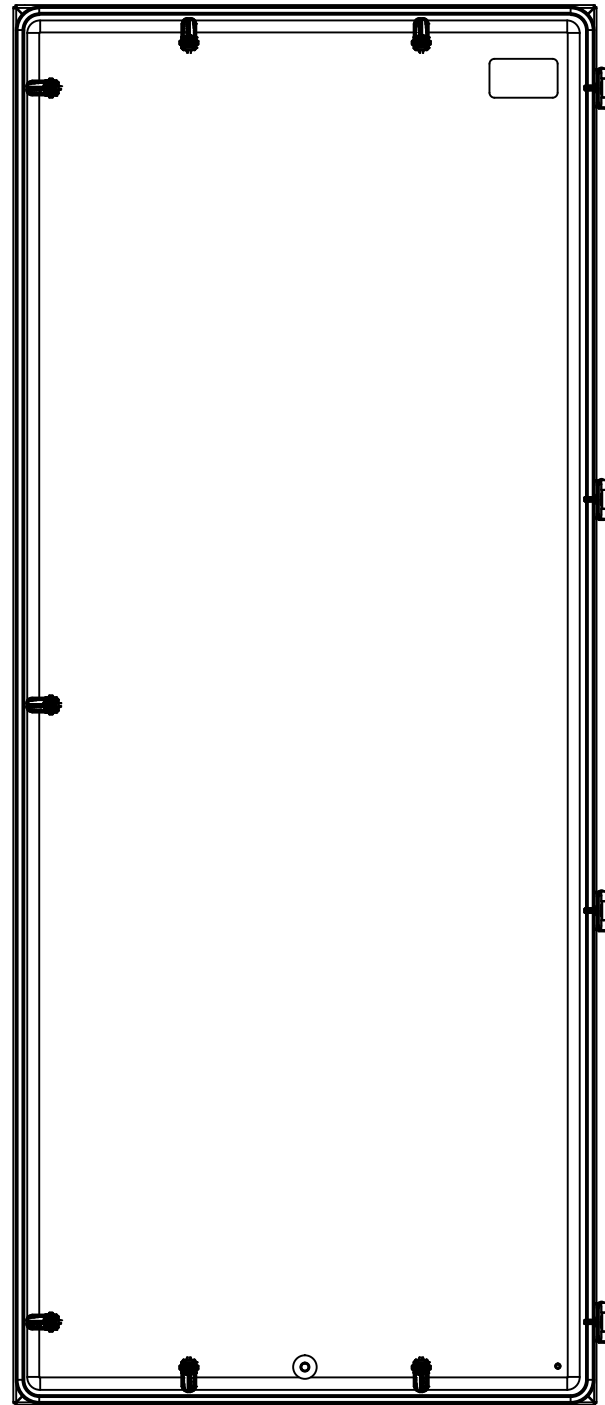

BACK



BOTTOM



LEFT

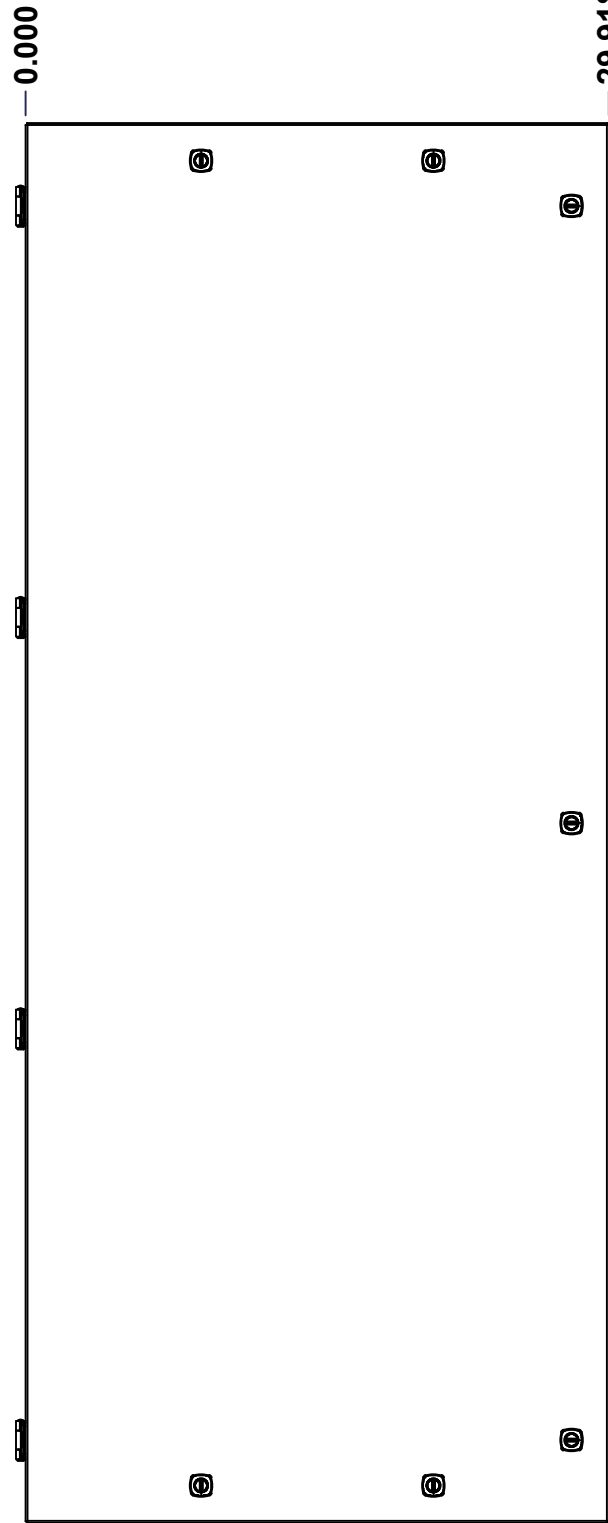

FRONT

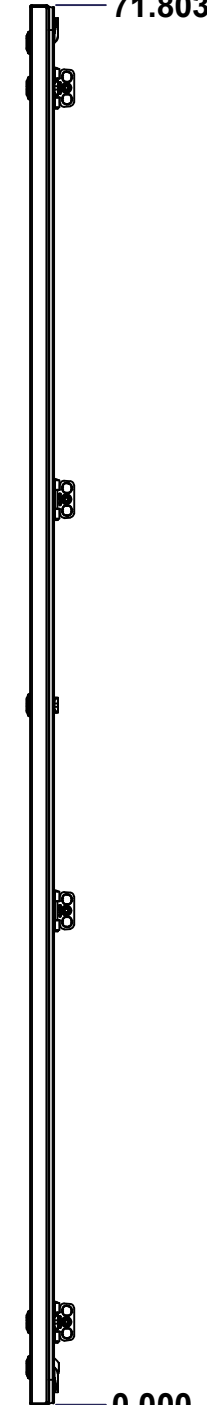

RIGHT

0.000  
0.934

0.000

29.918

71.803

0.000

No.	Revisions	Date	By/Par

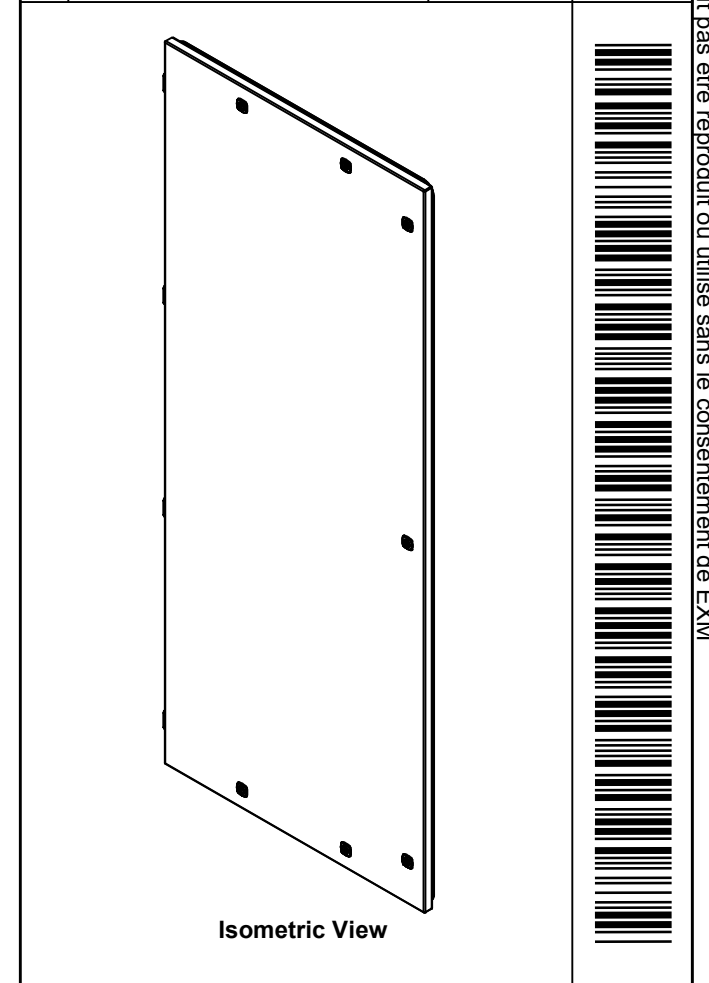

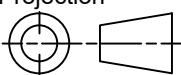
 Tél: (450) 979-4373 Fax: (450) 979-4626 <a href="http://www.exmweb.com">www.exmweb.com</a>		Flatness Aplatissement
		Max 3.0mm
Projection 		Date
Customer Client		Date 05-Dec-24
Drawn By Dessiné Par BoxCad: BoxCad		Date
Material Matière 14 Ga Cold Rolled A1008 CS Type B (1.7mm)		
Color Couleur	Asa-61 Grey	Finish Fini Smooth
Description 5412ESDG 72" x 30" Cover		Detail Rev.
Part Number Numéro Pièce 5412ESDG723020C		Rev. 7
SEE BILL OF MATERIAL ON LAST PAGE		0 9

This drawing is confidential and must not be reproduced or used without the consent of EXM

Ce dessin est confidentiel et ne doit pas être reproduit ou utilisé sans le consentement de EXM

**STANDARD FEATURES ARE NOT LISTED IN THIS HOLE TABLE**

**HOLE TABLE - FRONT VIEW (CUSTOM FEATURE ONLY)**

CUT-OUT	XDIM	YDIM	DESCRIPTION
1	14.959	1.435	STUD M6 x 18mm (Inside)
-----			
2	2.000	2.000	GND STUD M6 x 16mm (Inside)
3	3.750	68.053	LABEL_EXM (Inside)
4	27.994	35.901	LOCK 880 SCQ4-SL @ 0.0°
5	27.994	67.553	LOCK 880 SCQ4-SL @ 0.0°
6	27.994	4.250	LOCK 880 SCQ4-SL @ 0.0°
7	20.918	69.879	LOCK 880 SCQ4-SL @ 90.0°
8	9.000	1.924	LOCK 880 SCQ4-SL @ 270.0°
9	9.000	69.879	LOCK 880 SCQ4-SL @ 90.0°
10	20.918	1.924	LOCK 880 SCQ4-SL @ 270.0°

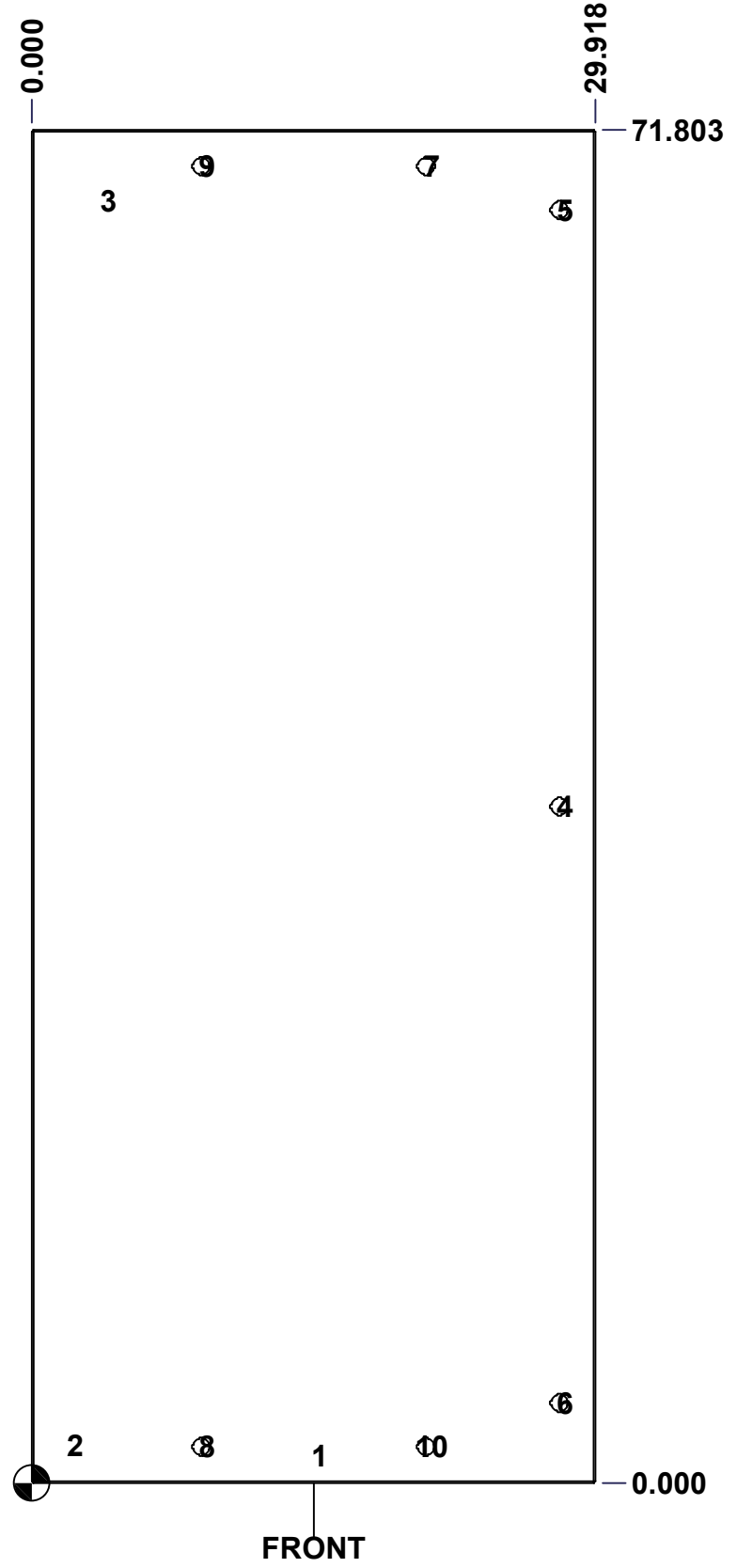

	Description	Status
	5412ESDG 72" x 30" Cover	(NULL)
	Part Number Numéro Pièce	Rev.
	<b>5412ESDG723020C</b>	<b>0</b> / 8 / 9

This drawing is confidential and must not be reproduced or used without the consent of EXM

Ce dessin est confidentiel et ne doit pas être reproduit ou utilisé sans le consentement de EXM

No.	Revisions	Date	By/Par

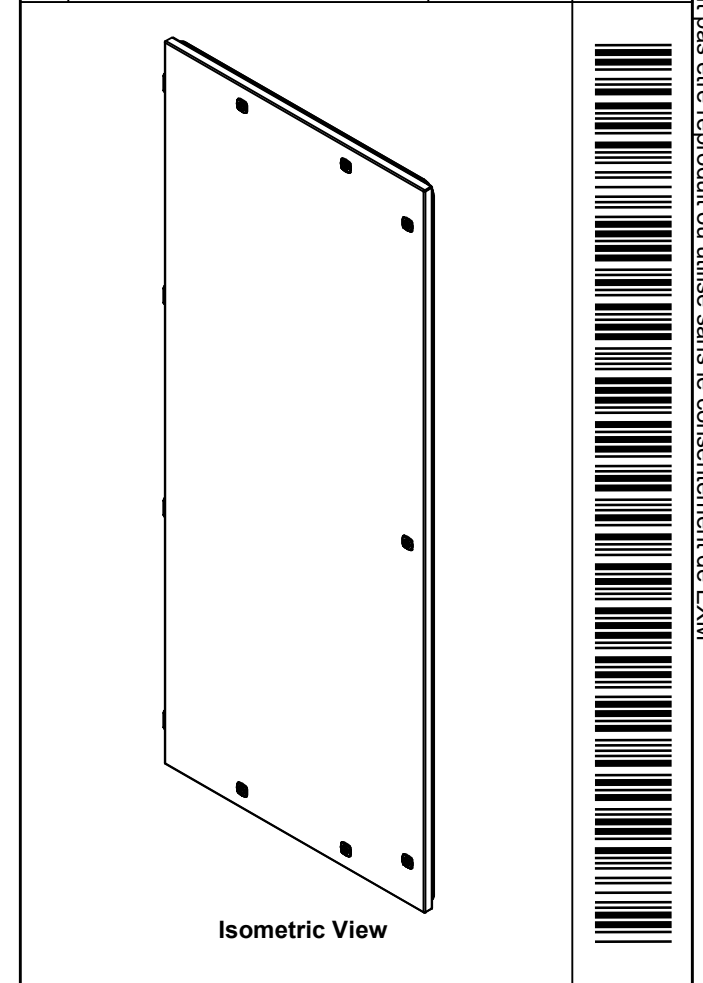

7	STK-K-12500	19	5412 ES 1/4 Turn Lock
1	STK-S-00100	0	3.5" x 2" Silver Milar Flexcon Sticker
1	STK-Q-16080	0	Ground Stud M6 x 16mm Steel
1	STK-P-02400S	0	Powder Paint (Asa-61 Grey / Smooth)
1	STK-Q-46515	3	5412 ES Door Support with Brass Insert
1	STK-Q-16055	1	M6 x 18mm Stud (No Paint Cap Required)
4	STK-Q-07220	1	M6 Nylon Insert Lock Nut
4	STK-Q-10252	0	M6 Stainless Steel Sealing Washer
4	STK-A-02360	2	External Hinge for Double Gasket
1	5412ESDG723020G2	0	5412ESDG 72" x 30" Cover Gasket
1	5412ESDG723020G	0	5412ESDG 72" x 30" Cover Gasket
1	5412ESDG723020C-P	0	5412ESDG 72" x 30" Cover Part
QTY	Part Number	Rev	Description
Parts List			

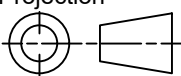
 Tél: (450) 979-4373 Fax: (450) 979-4626 <a href="http://www.exmweb.com">www.exmweb.com</a>		Flatness Aplatissement Max 3.0mm Projection 
Customer Client	Date	
Drawn By Dessiné Par	BoxCad: BoxCad	Date 05-Dec-24
Material Matière	14 Ga Cold Rolled A1008 CS Type B (1.7mm)	
Color Couleur	Asa-61 Grey	Finish Fini Smooth
Description		Detail Rev.
5412ESDG 72" x 30" Cover		
Part Number Numéro Pièce	Rev.	9
<b>5412ESDG723020C</b>	<b>0</b>	9

This drawing is confidential and must not be reproduced or used without the consent of EXM

Ce dessin est confidentiel et ne doit pas être reproduit ou utilisé sans le consentement de EXM

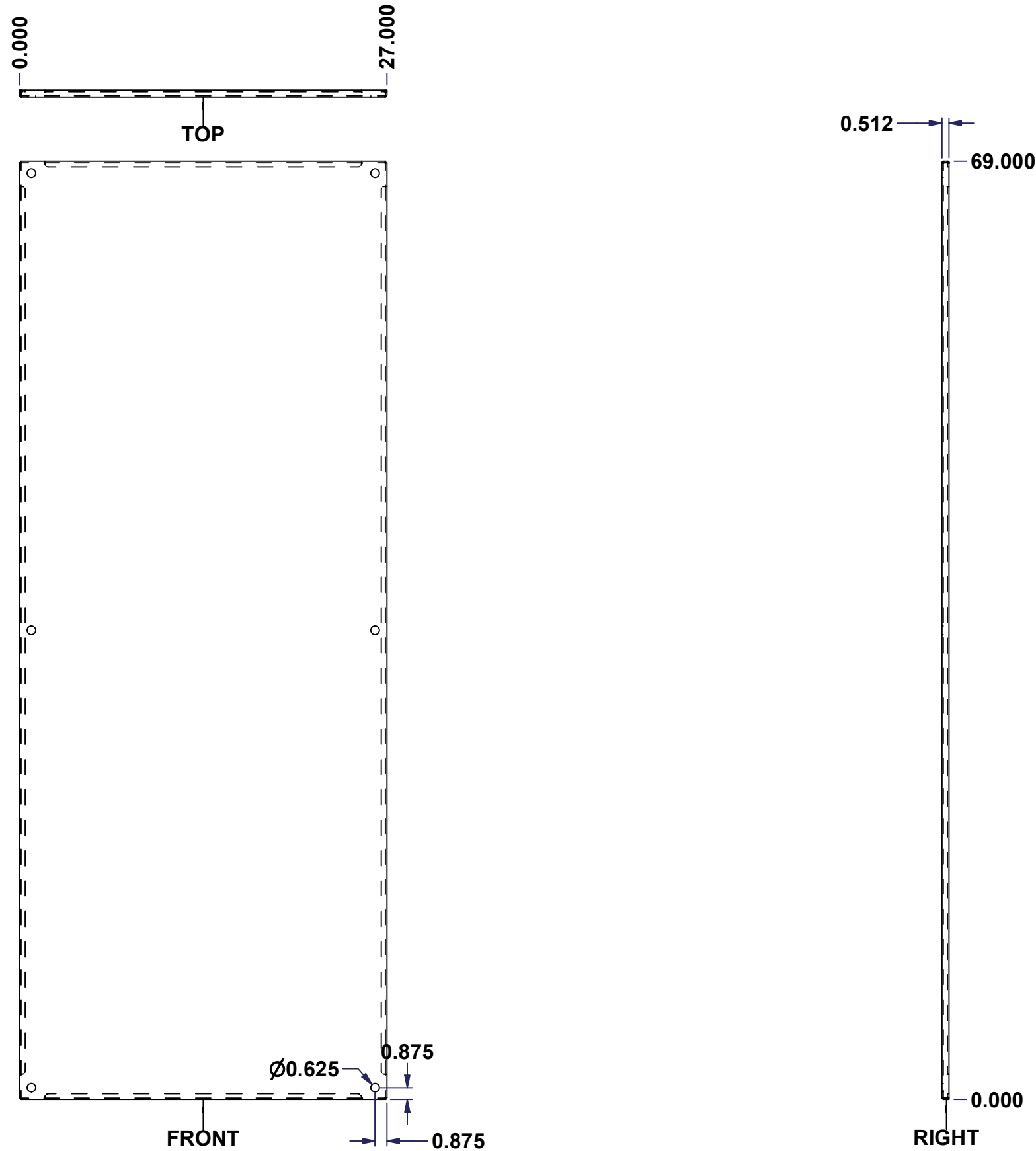

No.	Revisions	Date	By/Par

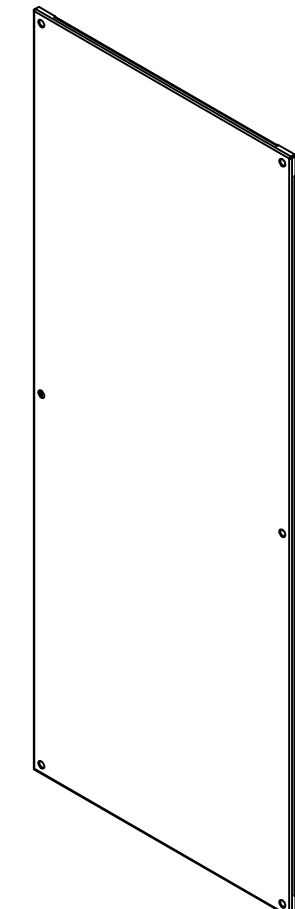

**Isometric View**

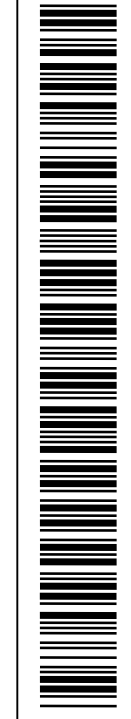

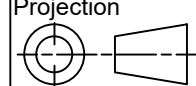
		Flatness Aplatissement Max 3.0mm	
Tél: (450) 979-4373 Fax: (450) 979-4626 <a href="http://www.exmweb.com">www.exmweb.com</a>		Projection 	
Customer Client		Date	
Drawn By Dessiné Par BoxCad: nickz		Date 01/03/2017	
Material Matière 12 Ga Galvanized (2.5mm)			
Color Couleur See Part List		Finish Fini See Part List	
Description 885SP 72" x 30" Inner Panel Part			Detail Rev.
Part Number Numéro Pièce <b>885SP7230G</b>			Rev. 1 <b>0</b>

Qty	Part Number	Rev	Description	Material	Color	Finish
1	885SP7230G-P	0	885SP 72" x 30" Inner Panel Part	12 Ga Galvanized (2.5mm)	Unpainted	Galvanized

Parts List